

# Saab 9000

Service Manual

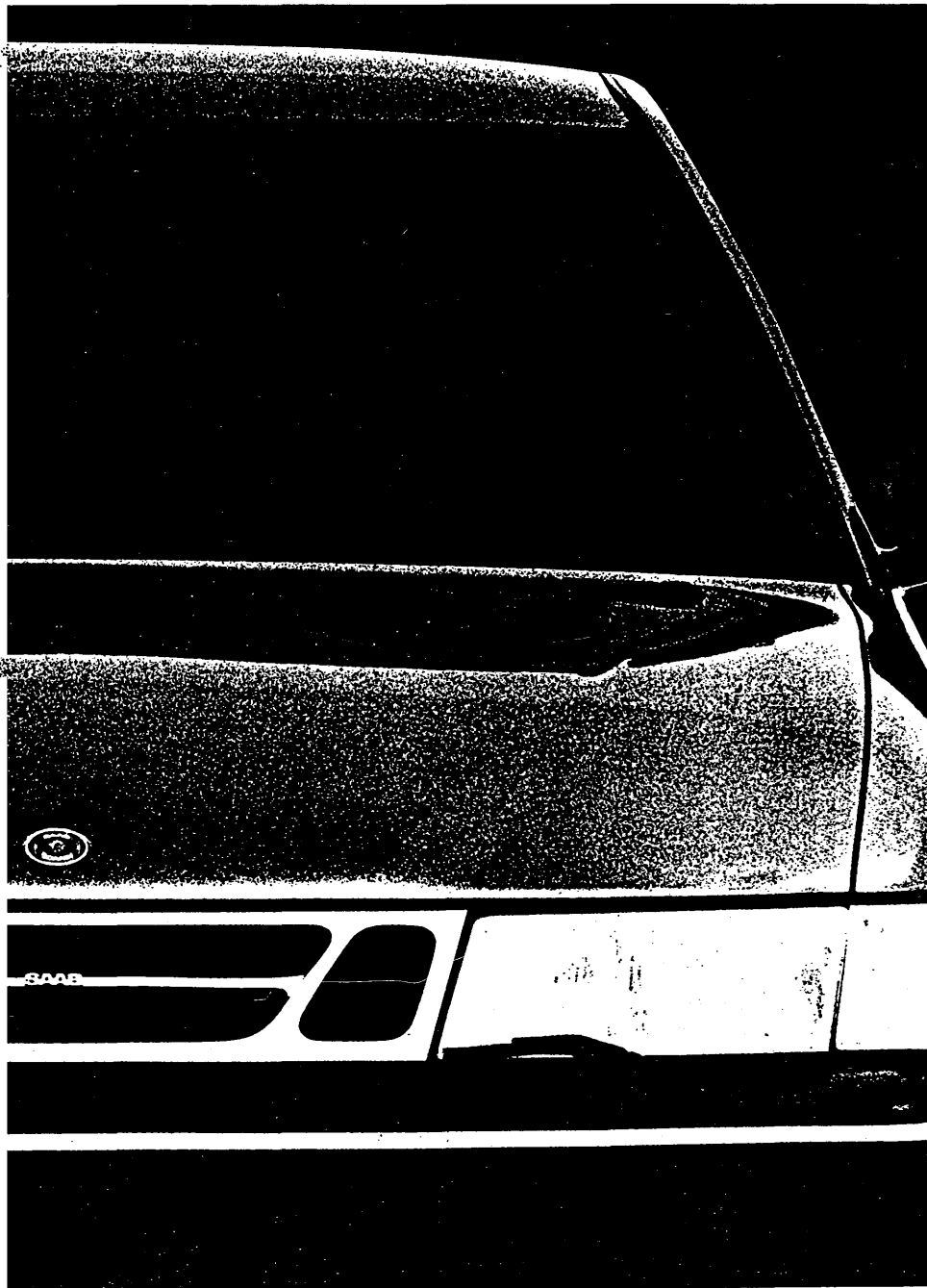

**M 1994-96**

ENG

## I Service

# Saab 9000

## SERVICE MANUAL

### 1 Service

M 1994 - 1996

#### Foreword

This Service Manual supersedes:

- Service Manual 1 Service M1994-1995
- Service Information 111-1550
- Service Information 113-1555

All particulars and illustrations in this Service Manual are based on the version of the cars prevailing at the time of going to press. Model variants, technical data and equipment vary from market to market and may be subject to alteration without prior notice.

Saab Automobile AB

Service programme	1
Acceptance inspection of a new car	2
In-storage car care	8
Pre-delivery service	13
Saab Original Service Programme EU	14
Saab Original Service Programme PA	16
Saab Original Service Programme FE/ME	18
Pre-delivery service	21
Saab Original Service	43
Lubrication, lubricants	65



RECYCLABLE PAPER

## Warning, Important and Note

The headings "Warning", "Important" and "Note" occur from time to time in the Service Manual. They are used to draw the attention of the reader to information of special interest and seriousness. The importance of the information is indicated by the three different headings and the difference between them is explained below.

### **WARNING**

Warns of the risk of material damage and grave injury to mechanics and the driver, as well as serious damage to the car.

---

### **Important**

Points out the risk of minor damage to the car and also warns the mechanic of difficulties and time-wasting mistakes.

---

### **Note**

Hints and tips on how the work can be done in a way that saves time and labour. This information is not supplied for reasons of safety.

### **Market codes**

The codes refer to market specifications.

AT	Austria	GB	Great Britain
AU	Australia	GR	Greece
BE	Belgium	IS	Iceland
CA	Canada	IT	Italy
CH	Switzerland	JP	Japan
DE	Germany	ME	Middle East
DK	Denmark	NL	Netherlands
ES	Spain	NO	Norway
EU	Europe	SE	Sweden
FE	Far East	US	USA
FI	Finland	UC	US California
FR	France		

# Service programme

## General

This Service Manual, 1 Service, contains our recommendations for pre-delivery and maintenance service on model year 1994, 1995 and 1996 Saab 9000 cars.

These recommendations are based on design constraints, the requirements of the authorities, and practical usage. The mileage intervals for checking and replacing consumable items are based on this. However, due to the relationship between time and mileage, some operating conditions will make annual service more suitable.

The owner's Service Card supplied with the Service Logbook is marked M94-96.

## Contents

The Manual begins with instructions for acceptance inspection of a new car and in-storage car care. This is followed by a run-down of the pre-delivery and maintenance programmes, which are covered point by point in methodical order. After the service programmes comes a description of the methods and relevant technical data for each service point.

### Important:

In all service work it is essential to follow the service schedule to be sure of carrying out the right service at the recommended service interval. The service schedule for the car's indicated mileage is itemized in the car's Service Logbook.

## Acceptance and storage of a new car

On acceptance of a new car, its specification must be checked. The car must also be inspected for damage. Defects and departures from the specification must be reported in accordance with special procedures. Afterwards, the car must be inspected during the time it is parked in storage to be sure that it is properly cared for while waiting for its new owner.

## Pre-delivery service

Customers base their opinions of Saab and you as a dealer on the condition of the car when it is collected. So pay attention to even the smallest details, such as making sure that there are no oil stains or smudges of dirt anywhere on the car, that the clock shows the right time, and so on.

All inspection, checking and adjustment points must be carried out conscientiously. Apart from this, unforeseeable defects may have been caused during transport and storage. These are to be regarded as repairs.

## Maintenance programmes

The programmes consist of service measures that must be carried out to maintain the car's high standard of safety and prevent faults from arising. They are also designed to ensure that the car will conform to exhaust emission control regulations, maintain a high standard of roadworthiness and be economical in use.

Maintenance is covered by service programmes at three levels.

### • Saab Original Service Programme EU

Recommended after the first 10,000 km (6,000 miles) and then at 20,000 km (12,000 mile) intervals, i.e. at odometer readings of 30,000 km (18,000 miles), 50,000 km (30,000 miles) and so on.

### • Saab Original Service Programme PA

Recommended after the first 15,000 km (9,200 miles) and then at 15,000 km intervals.

### • Saab Original Service Programme FE/ME

Recommended after the first 10,000 km and then at 10,000 km intervals.

The servicing intervals have been chosen with regard to the operating conditions prevailing in your market.

To ensure that the customer's car receives the correct service, the owner's Service Card is marked with the appropriate code next to its part number.

## Annual service

Annual service is recommended when the service interval mileages are not attained. The next service should then be carried out as shown by the rubber-stamp spaces in the Service Logbook.

### Important:

Inspection points and the replacement of consumable items which are subject to legal requirements should be carried out at the specified mileages only. These are marked with an asterisk \* in the service programme.



## Acceptance inspection of a new car

Acceptance inspection of a new car is obligatory for all Saab cars. See Policies and Procedures (P and P).

Carry out the inspection and checking procedures and confirm with your signature on the inspection sheet. Inspection sheet, see page 6.

### Acceptance inspection

A new car must be inspected as soon as possible after it has been accepted. The person responsible for acceptance must ensure that defects and deficiencies, etc. are reported in accordance with applicable procedures (see P and P).

- 1 Check that the specification of the car coincides with the order form. This also applies to optional equipment.
- 2 Check that the spare wheel, tools and other equipment supplied with the car are present.

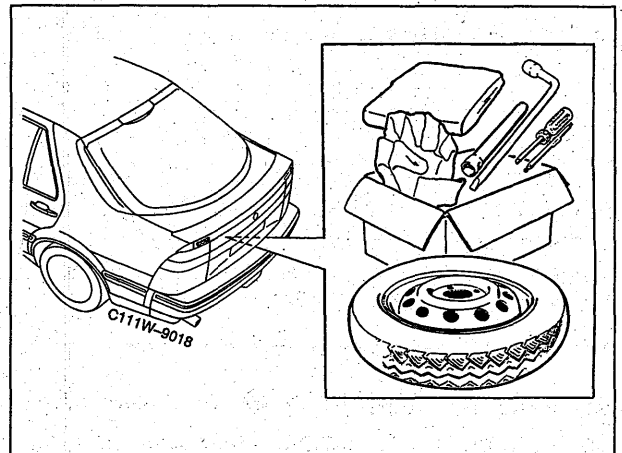
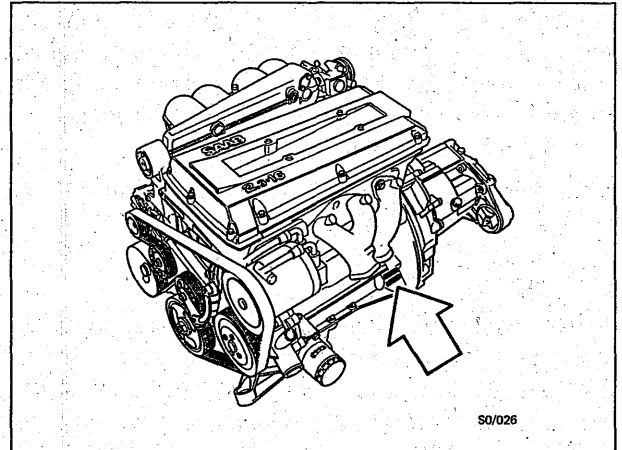

### 3 Check the battery voltage.

- Current consumption should be 0 A when tested.
- Check the condition of the battery by taking a voltage reading.
- Check the level of the electrolyte and top up to the normal level as necessary.

For further information, see Service Manual 3:1.

---

**Important:**

If the voltage reading obtained is below 12.4 V, the battery must be charged (fully charged battery = 12.72 V).

If the voltage reading obtained is below 12.0 V, the battery must be changed.

---

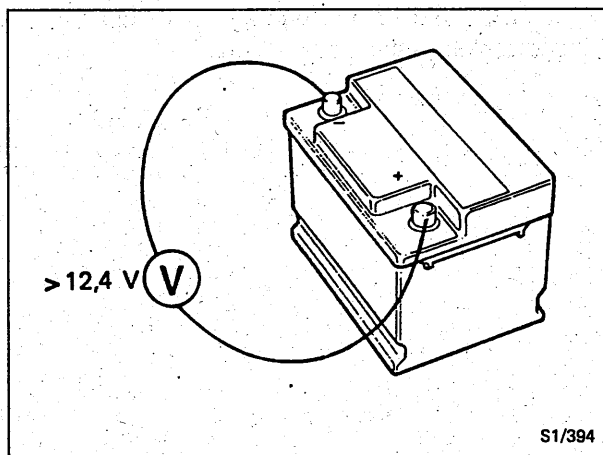

### 4 Clean the car for an inspection of the paintwork and possible damage.

If the car is to be placed in storage, wash off all dust and dirt prior to inspection without using Tempro 75 Remover (the paint protector will then remain intact).

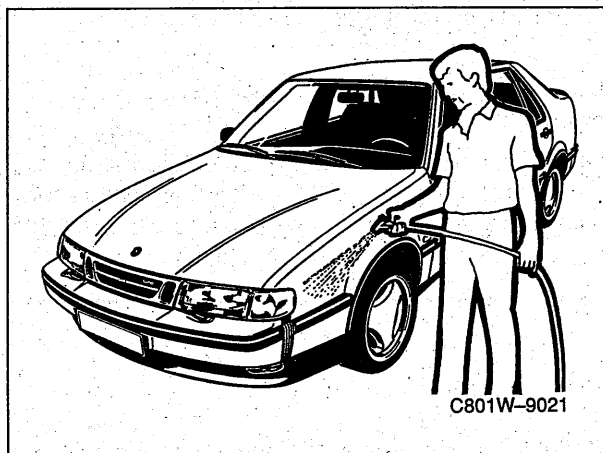

### 5 Check the interior of the car for damage.

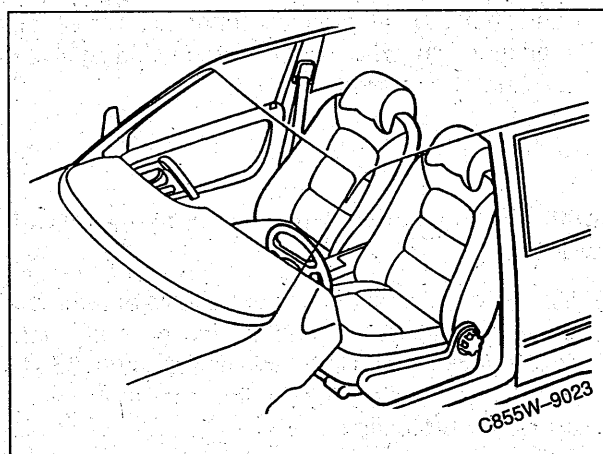

- 6 Make a note of any damage and report it together with other observations.

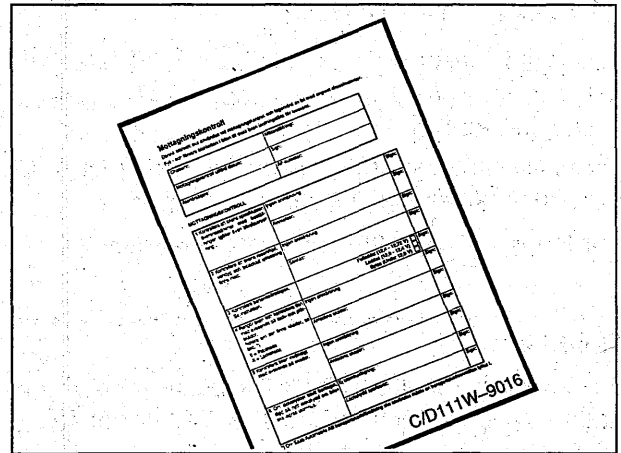

### Measures to take if the car is to be put in storage

- 7 Check the tyre pressures and adjust them if necessary to at least 3.5 bar (50 psi).

#### Important:

If the car is parked with the tyres inflated at too low a pressure, a flat area will form on them where they rest on the ground. This gives rise to vibration and makes wheel balancing more difficult.

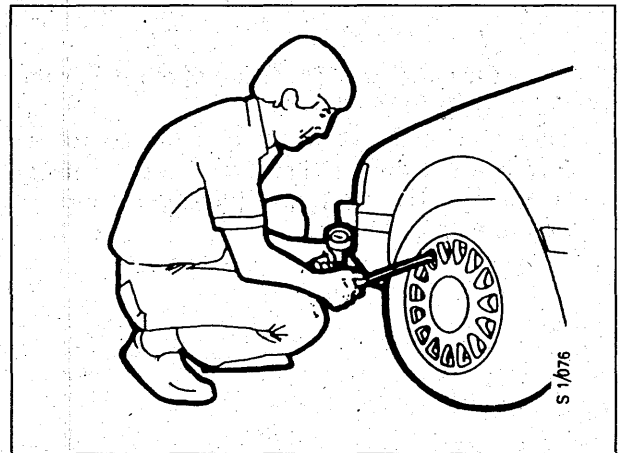

- 8 If the car is stored in a place where the ambient temperature is higher than +20°C, the petrol tank should be at least two-thirds full. If it is not, malfunctioning of the petrol pump could occur as a result of oxidation.

### Additional measures if the car is to be stored outdoors

- 9 Check the level of the coolant and its anti-freeze content. The coolant should provide protection from freezing down to between -30°C and -35°C. It will then also provide the maximum anti-corrosion protection.  
Top up as necessary with a mixture consisting of equal parts Saab Original coolant and water.

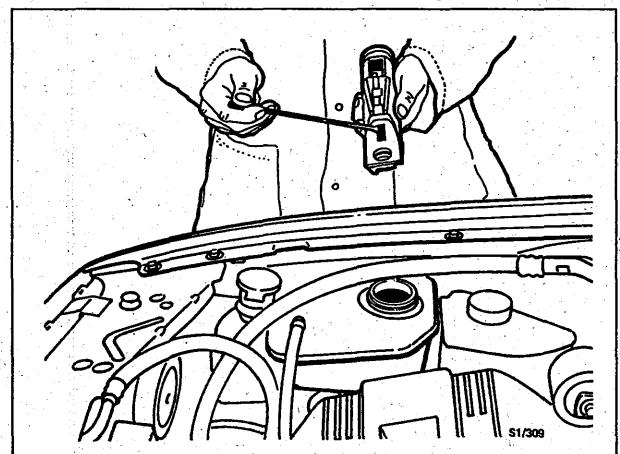

- 
- 10 If the car has been dewaxed, a new protective film must be applied. See under "Applying paint protector".
  - 11 Drive the car to the storage car park, applying the brakes briefly and repeatedly so that the brake discs will be clean and dry.
  - 12 Open the bonnet.
  - 13 Check and adjust the protective plastic that is out of place.
  - 14 Make sure that:
    - The handbrake lever is released.
    - Manual gearbox: engage reverse gear.
    - Automatic transmission: set the selector lever to the P position.
    - All windows, doors and tailgate are properly closed.
  - 15 Lock the car.
  - 16 Disconnect the positive cable from the battery or remove the battery for charging.  
Close the bonnet.

## Acceptance inspection

This form is to be used for acceptance inspection and in-storage care of the car with the specified chassis number.

Fill in the form and keep it in the car until the car is made ready for delivery.

Chassis No.:	Mileage (odometer reading):
Acceptance inspection date:	Sign.
Dealer:	Dealer number:

### ACCEPTANCE INSPECTION

1 Check that the specification of the car coincides with the order form (this also applies to optional equipment).	Nothing to report	Sign.
	Differences:	Sign.
2 Check that the spare wheel, tools and other equipment supplied with the car are present.	Nothing to report	Sign.
	Missing:	Sign.
3 Check the battery voltage. See instructions.	Fully charged (12.4 - 12.72 V) <input type="checkbox"/> Charge (12.0 - 12.4 V) <input type="checkbox"/> Change (below 12.0 V) <input type="checkbox"/>	Sign.
4 Clean the car and inspect it for paintwork and bodywork damage. Make a note of any damage found, see illustration. *) 0 = Body damage X = Paint damage	Nothing to report	Sign.
	Make a note of the damage:	Sign.
5 Check the interior of the car for damage.	Nothing to report	Sign.
	Make a note of the damage:	Sign.
6 If the paint protector has been removed, apply fresh paint protector if the car is to be stored outdoors.	Indoor storage:	Sign.
	Paint protector applied:	Sign.

\*) If Saab Automobile AB transit damage insurance is to be used, a transit damage report must be completed.

Saab 900

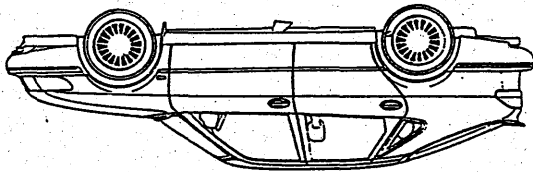
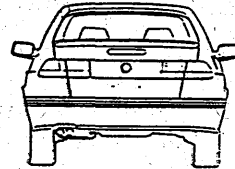
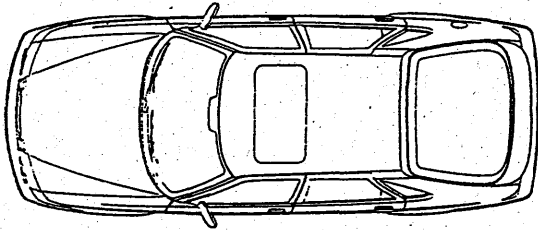
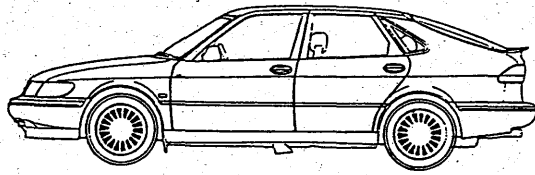

Saab 9000

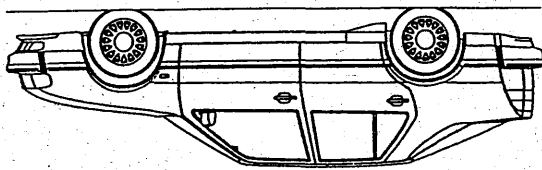
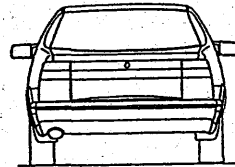
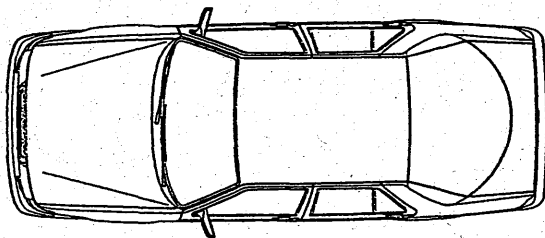
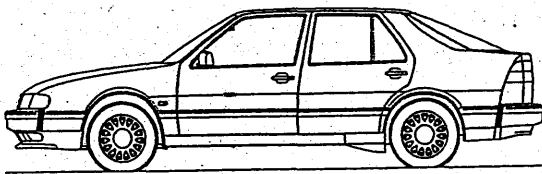

S1/395

## In-storage car care

In-storage car care is obligatory for all Saab cars at intervals of not more than 60 days until the car is sold. See Policies and Procedures (P and P).

Carry out the inspection and checking procedures and confirm with your signature on the inspection sheet. Inspection sheet, see page 11.

In connection with the rectification of defects and deficiencies, refer to the relevant service literature and follow the prescribed procedures.

### Inspection and rectification points

- 1 Check that the paint protector is intact. If it needs touching up, first wash the car thoroughly so that dust and dirt will not be enclosed by the fresh application of paint protector.  
Inspect the paintwork, make a note of any damage and apply fresh paint protector.

---

#### Important:

The paint protector is affected by UV radiation and heat, which cause it to harden. It must therefore be renewed at intervals of between three and six months. An interval of six months can be applied with safety only in wintertime.

For applying fresh paint protector, see under "Applying paint protector".

- 
- 2 Pour about two litres of petrol into the fuel tank to prevent dry running of the petrol pump.
  - 3 Check the battery voltage.
    - Current consumption should be 0 A when tested.
    - Check the condition of the battery by taking a voltage reading.
    - Check the level of the electrolyte and top up to the normal level as necessary.

For further information, see Service Manual 3:1.

---

#### Important:

If the voltage reading obtained is below 12.4 V, the battery must be charged (fully charged battery = 12.72 V).

If the voltage reading obtained is below 12.0 V, the battery must be changed.

---

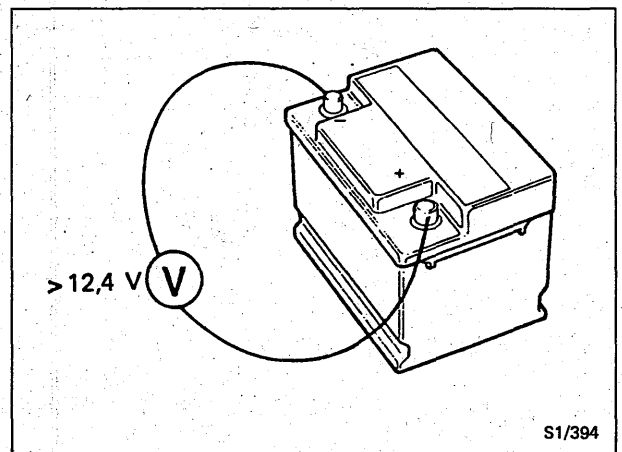

- 4 Start the engine and warm it up until the radiator fan starts.
- 5 Check the tyre pressures and adjust them if necessary to at least 3.5 bar (50 psi).

---

**Important:**

If the car is parked with the tyres inflated at too low a pressure, a flat area will form on them where they rest on the ground. This gives rise to vibration and makes wheel balancing more difficult.

---

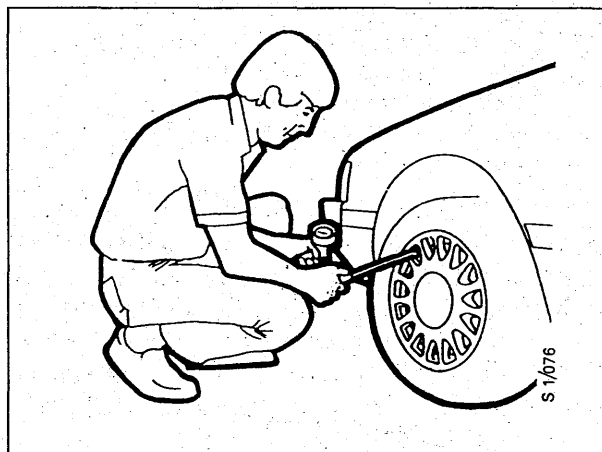

- 6 Check the level of the coolant.
- 7 Drive the car for at least 200 metres, applying the brakes briefly and repeatedly so that the brake discs will be clean and dry.
- 8 Park the car facing in the opposite direction to equalize the effect of sunlight on it.
- 9 Open the bonnet to cool the engine down more rapidly.
- 10 Check and adjust the protective plastic that is out of place.



- 11 Make sure that:
  - The handbrake lever is released.
  - Manual gearbox: engage reverse gear.
  - Automatic transmission: set the selector lever to the P position.
  - All windows, doors and tailgate are properly closed.
- 12 Lock the car.
- 13 Inspect the engine bay for incipient corrosion, particularly on aluminium components.
  - If corrosion is present, treat it with Teroson protection wax, part number (45) 30 15 914. Apply a coating of the wax without leaving any surplus (10-15  $\mu\text{m}$  when dry). Take special care with aluminium surfaces.

---

**Important:**

The protective wax may well be left on as engine bay protection when the car is delivered to a customer. If the customer will not accept the waxed surface, it must of course be washed off.

---

 **WARNING**

Danger of fire  
Make sure that the engine bay temperature has gone down.  
Do not spray directly onto the ends of the generator.

- 14 Disconnect the positive cable from the battery or remove the battery for charging.  
Close the bonnet.

## In-storage car care

This form is to be used for in-storage care of the car with the specified chassis number.

Fill in the form and keep it in the car until the car is made ready for delivery.

Chassis No.:	Mileage (odometer reading):
Dealer:	Dealer number:

### IN-STORAGE CAR CARE

1 In-storage car care date:		Sign.
Check the battery voltage. (Mark with an X as appropriate.)	Fully charged (12.4 - 12.72 V) <input type="checkbox"/> Charge (12.0 - 12.4 V) <input type="checkbox"/> Change (below 12.0 V) <input type="checkbox"/>	Sign.
Car dewaxed and paint protector applied		Sign.

2 In-storage car care date:		Sign.
Check the battery voltage. (Mark with an X as appropriate.)	Fully charged (12.4 - 12.72 V) <input type="checkbox"/> Charge (12.0 - 12.4 V) <input type="checkbox"/> Change (below 12.0 V) <input type="checkbox"/>	Sign.
Car dewaxed and paint protector applied		Sign.

3 In-storage car care date:		Sign.
Check the battery voltage. (Mark with an X as appropriate.)	Fully charged (12.4 - 12.72 V) <input type="checkbox"/> Charge (12.0 - 12.4 V) <input type="checkbox"/> Change (below 12.0 V) <input type="checkbox"/>	Sign.
Car dewaxed and paint protector applied		Sign.

4 In-storage car care date:		Sign.
Check the battery voltage. (Mark with an X as appropriate.)	Fully charged (12.4 - 12.72 V) <input type="checkbox"/> Charge (12.0 - 12.4 V) <input type="checkbox"/> Change (below 12.0 V) <input type="checkbox"/>	Sign.
Car dewaxed and paint protector applied		Sign.

### Applying paint protector

Paint protector: part number (45) 30 02 516.

Water-based Acrylate Latex containing only 1% of solvent.

Apply the liquid by means of an airless low-pressure spray gun or paint sprayer.

Spray a covering layer without any surplus on all vertical surfaces.

---

#### Important:

Apply the paint protector without any surplus (5-10  $\mu\text{m}$  when dry). An excessively thick layer will make the paint protector much more difficult to remove.

---

Drying time: Apply a couple of drops of water to the paint protector. If it turns white, the car must be left to dry for a somewhat longer time before it is driven out to the storage area.

Do not apply paint protector in the rain or in direct sunlight.

#### Directions

 **WARNING**

Wear suitable protective equipment, such as a respirator, gloves, goggles and boots.

Make sure the area is well ventilated.

#### First aid

##### Inhalation:

Take the person out into the fresh air and give respiratory aid if necessary.

Give the person **nothing** to drink!

Call a doctor.

##### Splashes in eyes:

Hold the eyelids open and rinse with clean water for **at least 10 minutes**.

##### Skin contact:

Take off contaminated clothing. Wash the affected skin area thoroughly with soap and clean water.

Do **not** use solvents.

##### Swallowed liquid:

Lay the person down in a position of rest. Call a doctor.

Do **not** provoke vomiting.

### Summary of materials

Protective wax for the engine bay. Part number: (45) 30 15 914, 300 ml spray container.

Paint protector. Part number: (45) 30 02 516. Quantity: 10 litres.

## Pre-delivery service

- 1 Washer fluid, top up.
- 2 Insert the logic module fuses and relay for the electrically adjustable seats.
- 3 Programming the anti-theft alarm.  
Affixing labels, anti-theft alarm.
- 4 OBD II specification car: Plug in an ISAT scan tool and clear any diagnostic trouble codes in the engine and automatic transmission management systems (only USA, Canada).
- 5 Programming the ACC unit.
- 6 Set the clock to the right time, program the Audio System anti-theft code.
- 7 Check operation of wash-wipe systems.
- 8 Tyre pressures, check and adjust.
- 9 Wheel bolts, tighten with prescribed torque.
- 10 Check oil and fluid levels, inspect for leaks, top up. Engine, automatic transmission and power steering.
- 11 Check coolant and fluid levels, inspect for leaks, top up as necessary. Cooling system, brake and clutch systems.
- 12 Turbo: Plug the electric lead into the boost pressure control valve.
- 13 Raise the car and inspect the underbody for transport damage.  
Note that corrosion protection (underseal) should also be intact.
- 14 Front assembly, retighten MacPherson strut mounting - body
- 15 Remove the transit brackets and mountings.
- 16 Fit and adjust the equipment supplied with the car.
- 17 Cars for the European market: "Certificate of Conformity".
- 18 Road test
- 19 OBD II specification car: Plug in an ISAT scan tool and check that no new diagnostic trouble codes have been detected in the engine and automatic transmission management systems (only USA, Canada).
- 20 Cleaning.

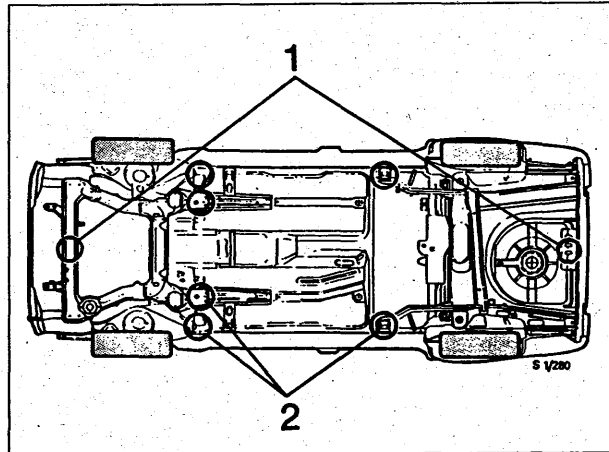

- 1 Lifting points for garage jack.
- 2 Lifting points for car lift.

## Saab Original Service Programme EU

This service programme is designed for the operating conditions prevailing in Europe and comparable conditions elsewhere.

The owner's Service Card is marked with a code next to the card's part number. If the code is EU, this service programme should be followed.

### WARNING

Lengthy and repeated contact with mineral oil removes the natural oils of your skin, drying it out and causing irritation. If oil has been swallowed, do not provoke vomiting. Call a doctor.

Waste oil may contain harmful impurities which can cause skin cancer. Always use suitable protection and thoroughly wash your hands and other areas of bare skin that have come into contact with the oil.

Observe the following safety rules:

- Avoid lengthy and repeated contact with oil, grease, etc. and especially waste oil.
- Wear protective clothing, including impermeable gloves, if possible.
- Do not put oily rags in your pockets.
- Do not wear clothes that have been soiled by oil, especially items of underwear. Clothes must be washed at regular intervals.
- Do not wear oily shoes.
- Clean open sores immediately and cover them with an adhesive bandage, sticking plaster, etc.
- Use barrier cream, part No. (45) 30 04 397. Apply it to your exposed skin before each working period so that it will be easier for you to wash oil and grease off afterwards.
- Remove oil from your face and hands, etc. by washing them thoroughly with soap and water (special skin cleansers and a nailbrush will help). Preparations containing lanolin will restore the skin's natural moisture.
- Do not use petrol, paraffin, diesel oil, thinner or solvents to remove oil from any part of your body.
- If you notice any changes in your skin, consult a doctor without delay.
- If possible, clean the parts before starting work.
- If there is a danger of oil getting into your eyes, wear protective goggles, a visor or a face mask. Eye-washing equipment must also be readily available.

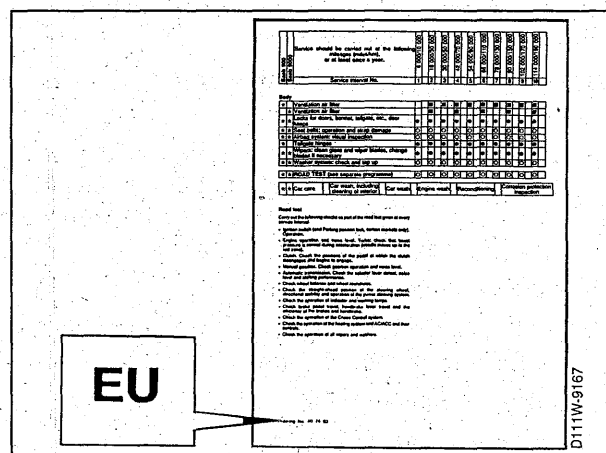

Service interval (km)	10000	20000	30000	40000	50000	60000	70000	80000	90000	100000
Oil service	✓	✓	✓	✓	✓	✓	✓	✓	✓	✓
Oil filter	✓	✓	✓	✓	✓	✓	✓	✓	✓	✓
Water pump										
Timing belt										
Timing chain										
Water pump										
Timing belt										
Timing chain										
Water pump										
Timing belt										
Timing chain										
Water pump										

**Checklist:**

Check oil level and quality  
 Check oil filter  
 Check water pump  
 Check timing belt/chain  
 Check timing belt/chain tension  
 Check timing belt/chain guide  
 Check timing belt/chain pulley  
 Check timing belt/chain cover  
 Check timing belt/chain seal  
 Check timing belt/chain bracket  
 Check timing belt/chain roller  
 Check timing belt/chain guide  
 Check timing belt/chain pulley  
 Check timing belt/chain cover  
 Check timing belt/chain seal  
 Check timing belt/chain bracket  
 Check timing belt/chain roller  
 Check timing belt/chain guide

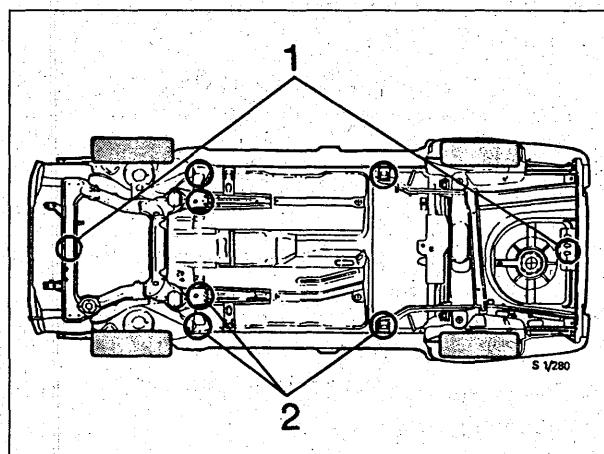

- 1 Lifting points for garage jack.  
 2 Lifting points for car lift.

**Key to table**

○ = check/adjust

■ = replace

⊗ = inspect/adjust/clean/lubricate

\* = mileage-based service point only

**Saab Original Service Programme EU**

	SERVICE INTERVAL									
	(See Service Logbook for correct mileage)									
	1	2	3	4	5	6	7	8	9	10
Lighting (headlamps, light clusters, other lights), alignment	○	○	○	○	○	○	○	○	○	○
Oil leakage, top/bottom	○	○	○	○	○	○	○	○	○	○
Engine: oil and oil filter	■	■	■	■	■	■	■	■	■	■
Automatic transmission: fluid and filter			■		■		■		■	
Manual gearbox: oil level		○		○		○		○		○
* Fuel filter									■	
Brake system: pads/discs, wear and condition		○	○	○	○	○	○	○	○	○
Brake lines and hoses: damage and leaks		○	○	○	○	○	○	○	○	○
Dampers and bushes: integrity and condition		○		○		○		○		○
Gaiters, inboard and outboard drive-shaft universal joints		○	○	○	○	○	○	○	○	○
Exhaust system and mountings: integrity and damage		○	○	○	○	○	○	○	○	○
Front and rear suspension threaded joints: retighten	○									
Play in steering joints and ball joints, gaiter integrity		○	○	○	○	○	○	○	○	○
Tyres: inflation pressures, condition, tread depth and wear pattern (incl. spare wheel)	○	○	○	○	○	○	○	○	○	○
Fuel system, incl. tank: leaks and damage		○	○	○	○	○	○	○	○	○
Coolant (max. 3-year intervals)					■				■	
Cooling system: condition of hoses, check coolant level and freezing point.	○	○	○	○	○	○	○	○	○	○
Brake fluid: level (change at max. 2-year intervals)	○	○	■	○	○	■	○	■	○	■
Automatic transmission: fluid level		○		○		○		○		○
Power steering: fluid level	○	○	○	○	○	○	○	○	○	○
Throttle body: clean (not V6)		⊗	⊗	⊗	⊗	⊗	⊗	⊗	⊗	⊗
* Spark plugs, for unleaded petrol			■			■			■	
* Spark plugs, for leaded petrol		■	■	■	■	■	■	■	■	■
* Air cleaner filter element			■			■			■	
Drive belts: condition, tension, incl. automatic tensioner. Replace as necessary			○		○	○	○	○	○	○
* Camshaft transmission, drive belt (V6)			■			■			■	
Battery: check electrolyte level, ground and battery cables, clean and grease terminals and mounting bracket.	⊗	⊗	⊗	⊗	⊗	⊗	⊗	⊗	⊗	⊗
Washer system: check and top up as necessary	○	○	○	○	○	○	○	○	○	○
Wipers	○	○	○	○	○	○	○	○	○	○
Ventilation air filter		■		■		■		■		■
Doors, bonnet, tailgate, etc. and door keeps	⊗	⊗	⊗	⊗	⊗	⊗	⊗	⊗	⊗	⊗
Seat belts: operation and strap damage	○	○	○	○	○	○	○	○	○	○
Toe-in	○		○		○		○		○	
Airbag system: visual inspection of airbag module/modules	○	○	○	○	○	○	○	○	○	○
Road test (see separate road test programme)	○	○	○	○	○	○	○	○	○	○

## Saab Original Service Programme PA

This service programme is designed for the operating conditions prevailing in the Pacific Area and comparable conditions elsewhere.

The owner's Service Card is marked with a code next to the card's part number. If the code is PA, this service programme should be followed.

### ⚠ WARNING

Lengthy and repeated contact with mineral oil removes the natural oils of your skin, drying it out and causing irritation. If oil has been swallowed, do not provoke vomiting. Call a doctor.

Waste oil may contain harmful impurities which can cause skin cancer. Always use suitable protection and thoroughly wash your hands and other areas of bare skin that have come into contact with the oil.

Observe the following safety rules:

- Avoid lengthy and repeated contact with oil, grease, etc. and especially waste oil.
- Wear protective clothing, including impermeable gloves, if possible.
- Do not put oily rags in your pockets.
- Do not wear clothes that have been soiled by oil, especially items of underwear. Clothes must be washed at regular intervals.
- Do not wear oily shoes.
- Clean open sores immediately and cover them with an adhesive bandage, sticking plaster, etc.
- Use barrier cream, part No. (45) 30 04 397. Apply it to your exposed skin before each working period so that it will be easier for you to wash oil and grease off afterwards.
- Remove oil from your face and hands, etc. by washing them thoroughly with soap and water (special skin cleansers and a nailbrush will help). Preparations containing lanolin will restore the skin's natural moisture.
- Do not use petrol, paraffin, diesel oil, thinner or solvents to remove oil from any part of your body.
- If you notice any changes in your skin, consult a doctor without delay.
- If possible, clean the parts before starting work.
- If there is a danger of oil getting into your eyes, wear protective goggles, a visor or a face mask. Eye-washing equipment must also be readily available.

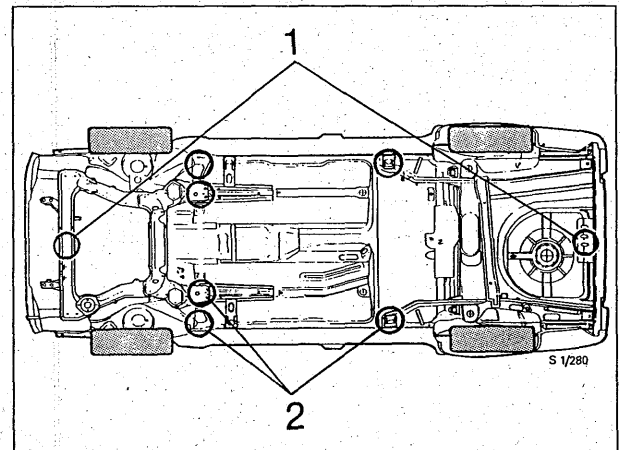
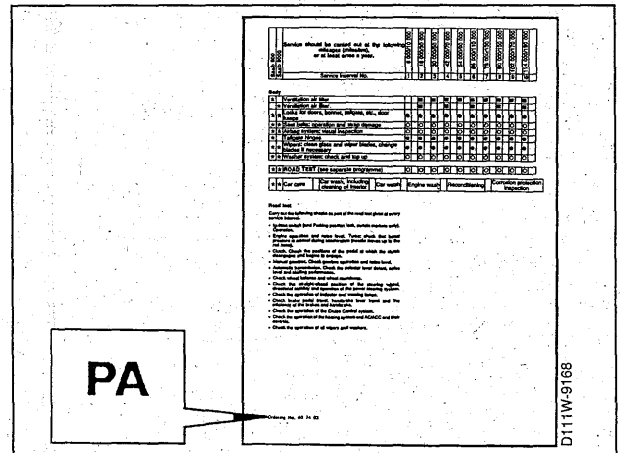

- 1 Lifting points for garage jack.
- 2 Lifting points for car lift.

**Key to table**

○ = check/adjust

■ = replace

⊗ = inspect/adjust/clean/lubricate

**Saab Original Service Programme PA**

	SERVICE INTERVAL													
	(See Service Logbook for correct mileage)													
	1	2	3	4	5	6	7	8	9	10	11	12	13	14
Lighting (headlamps, light clusters, other lights), alignment	○	○	○	○	○	○	○	○	○	○	○	○	○	○
Oil leakage, top/bottom	○	○	○	○	○	○	○	○	○	○	○	○	○	○
Engine: oil and oil filter	■	■	■	■	■	■	■	■	■	■	■	■	■	■
Automatic transmission: fluid		■		■		■		■		■		■		■
Manual gearbox: oil level		○		○		○		○		○		○		○
Fuel filter				■				■				■		
Brake system: discs, wear and general condition	○	○	○	○	○	○	○	○	○	○	○	○	○	○
Brake lines and hoses: damage and leaks		○		○		○		○		○		○		○
Dampers and bushes: integrity and condition		○		○		○		○		○		○		○
Gaiters, inboard and outboard drive-shaft universal joints		○		○		○		○		○		○		○
Exhaust system and mountings: integrity and damage	○	○	○	○	○	○	○	○	○	○	○	○	○	○
Front and rear suspension threaded joints: retighten	○													
Play in steering joints and ball joints, gaiter integrity		○		○		○		○		○		○		○
Tyres: inflation pressures, condition, tread depth and wear pattern (incl. spare wheel)	○	○	○	○	○	○	○	○	○	○	○	○	○	○
Fuel system, incl. tank: leaks and damage		○		○		○		○		○		○		○
Coolant (max. 3-year intervals)						■						■		
Cooling system: condition of hoses, check coolant level and freezing point.	○	○	○	○	○	○	○	○	○	○	○	○	○	○
Brake fluid: level (change at max. 2-year intervals)	○	○	○	■	○	○	○	■	○	○	○	■	○	○
Automatic transmission: fluid level			○		○		○		○		○		○	
Power steering: fluid level	○	○	○	○	○	○	○	○	○	○	○	○	○	○
Throttle body: clean (not V6)	⊗	⊗	⊗	⊗	⊗	⊗	⊗	⊗	⊗	⊗	⊗	⊗	⊗	⊗
Spark plugs, for unleaded petrol				■				■				■		
Spark plugs, for leaded petrol		■		■		■		■		■		■		■
Air cleaner filter element				■				■				■		
Drive belt: condition, tension, incl. automatic tensioner. Replace as necessary		○		○		○		○		○		○		○
Camshaft transmission, drive belt (V6)				■				■				■		
Battery: check electrolyte level, ground and starter motor cables, clean and grease terminals and mounting bracket.	⊗	⊗	⊗	⊗	⊗	⊗	⊗	⊗	⊗	⊗	⊗	⊗	⊗	⊗
Washer system: check and top up as necessary	○	○	○	○	○	○	○	○	○	○	○	○	○	○
Wipers	○	○	○	○	○	○	○	○	○	○	○	○	○	○
Ventilation air filter		■		■		■		■		■		■		■
Doors, bonnet, tailgate, etc. and door keeps		⊗		⊗		⊗		⊗		⊗		⊗		⊗
Tailgate hinges		⊗		⊗		⊗		⊗		⊗		⊗		⊗
Seat belts: operation and strap damage		○		○		○		○		○		○		○
Toe-in	○			○		○		○		○		○		○
Airbag system: visual inspection of airbag module/modules		○		○		○		○		○		○		○
Road test (see separate road test programme)	○	○	○	○	○	○	○	○	○	○	○	○	○	○



## Saab Original Service Programme FE/ME

This service programme is designed for the operating conditions prevailing in the Middle East and comparable conditions elsewhere.

The owner's Service Card is marked with a code next to the card's part number. If the code is FE/ME (or on earlier cards Heavy Duty), this service programme should be followed.

### WARNING

Lengthy and repeated contact with mineral oil removes the natural oils of your skin, drying it out and causing irritation. If oil has been swallowed, do not provoke vomiting. Call a doctor.

Waste oil may contain harmful impurities which can cause skin cancer. Always use suitable protection and thoroughly wash your hands and other areas of bare skin that have come into contact with the oil.

Observe the following safety rules:

- Avoid lengthy and repeated contact with oil, grease, etc. and especially waste oil.
- Wear protective clothing, including impermeable gloves, if possible.
- Do not put oily rags in your pockets.
- Do not wear clothes that have been soiled by oil, especially items of underwear. Clothes must be washed at regular intervals.
- Do not wear oily shoes.
- Clean open sores immediately and cover them with an adhesive bandage, sticking plaster, etc.
- Use barrier cream, part No. (45) 30 04 397. Apply it to your exposed skin before each working period so that it will be easier for you to wash oil and grease off afterwards.
- Remove oil from your face and hands, etc. by washing them thoroughly with soap and water (special skin cleansers and a nailbrush will help). Preparations containing lanolin will restore the skin's natural moisture.
- Do not use petrol, paraffin, diesel oil, thinner or solvents to remove oil from any part of your body.
- If you notice any changes in your skin, consult a doctor without delay.
- If possible, clean the parts before starting work.
- If there is a danger of oil getting into your eyes, wear protective goggles, a visor or a face mask. Eye-washing equipment must also be readily available.

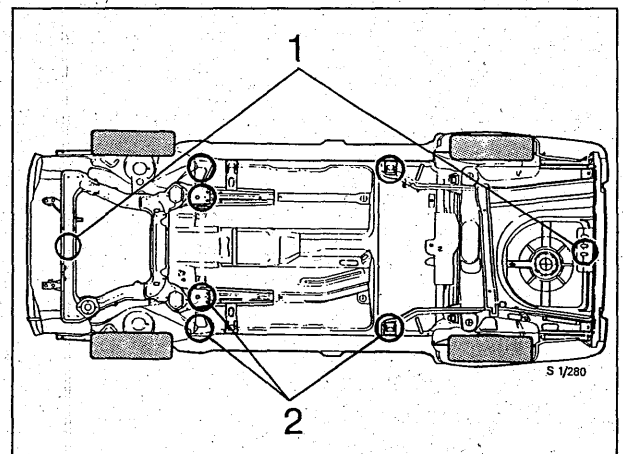
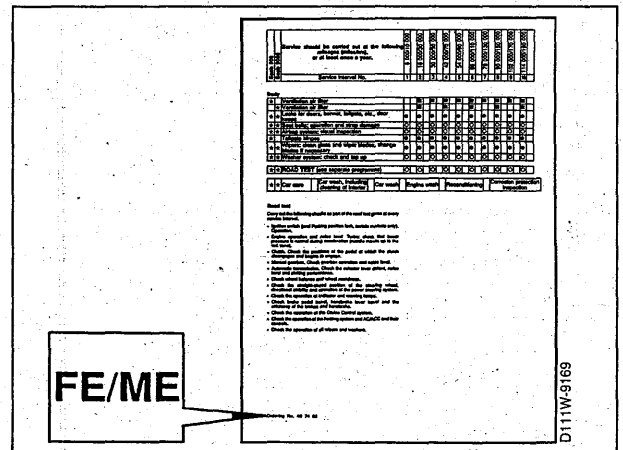

- 1 Lifting points for garage jack.
- 2 Lifting points for car lift.

**Key to table**

○ = check/adjust

■ = replace

⊗ = inspect/adjust/clean/lubricate

**Saab Original Service Programme  
FE/ME**

	SERVICE INTERVAL																			
	(See Service Logbook for correct mileage)																			
	1	2	3	4	5	6	7	8	9	10	11	12	13	14	15	16	17	18	19	20
Lighting (headlamps, light clusters, other lights), alignment	○	○	○	○	○	○	○	○	○	○	○	○	○	○	○	○	○	○	○	○
Oil leakage, top/bottom	○	○	○	○	○	○	○	○	○	○	○	○	○	○	○	○	○	○	○	○
Engine: oil and oil filter	■	■	■	■	■	■	■	■	■	■	■	■	■	■	■	■	■	■	■	■
Automatic transmission: fluid			■				■				■				■				■	
Manual gearbox: oil level			○				○				○				○				○	
Fuel filter					■						■								■	
Brake system: pads, discs, wear and condition	○		○		○		○		○		○		○		○		○		○	
Brake lines and hoses: damage and leaks			○		○		○		○		○		○		○		○		○	
Dampers and bushes: integrity and condition			○				○				○		○		○		○		○	
Gaiters, inboard and outboard drive-shaft universal joints			○		○		○		○		○		○		○		○		○	
Exhaust system and mountings: integrity and damage			○		○		○		○		○		○		○		○		○	
Front and rear suspension threaded joints: retighten	○																			
Play in steering joints and ball joints, gaiter integrity			○		○		○		○		○		○		○		○		○	
Tyres: inflation pressures, condition, tread depth and wear pattern (incl. spare wheel)	○	○	○	○	○	○	○	○	○	○	○	○	○	○	○	○	○	○	○	
Fuel system, incl. tank: leaks and damage			○		○		○		○		○		○		○		○		○	
Coolant (max. 3-year intervals)									■										■	
Cooling system: condition of hoses, check coolant level and freezing point.	○	○	○	○	○	○	○	○	○	○	○	○	○	○	○	○	○	○	○	
Brake fluid: level (change at max. 1-year intervals)	○	○	○	○	■	○	○	○	■	○	○	○	■	○	○	○	■	○	○	
Automatic transmission: fluid level					○				○				○				○			
Power steering: fluid level	○		○		○		○		○		○		○		○		○		○	
Throttle body: clean (not V6)	⊗	⊗	⊗	⊗	⊗	⊗	⊗	⊗	⊗	⊗	⊗	⊗	⊗	⊗	⊗	⊗	⊗	⊗	⊗	
Spark plugs, for unleaded petrol					■						■						■			
Spark plugs, for leaded petrol		■		■		■		■		■		■		■		■		■		
Air cleaner filter element	○		○		■		○		○		■		○		○		■		○	
Drive belts: condition, tension, incl. automatic tensioner. Replace as necessary	○		○		○		○		○		○		○		○		○		○	
Camshaft transmission, drive belt (V6)					■						■						■			
Battery: check electrolyte level, inspect ground and starter motor cables, clean and grease terminals and mounting bracket.	⊗	⊗	⊗	⊗	⊗	⊗	⊗	⊗	⊗	⊗	⊗	⊗	⊗	⊗	⊗	⊗	⊗	⊗	⊗	
Washer system: check and top up as necessary	○	○	○	○	○	○	○	○	○	○	○	○	○	○	○	○	○	○	○	
Wipers	○	○	○	○	○	○	○	○	○	○	○	○	○	○	○	○	○	○	○	
Ventilation air filter			■				■				■				■				■	
Doors, bonnet, tailgate, etc. and door keeps	⊗		⊗		⊗		⊗		⊗		⊗		⊗		⊗		⊗		⊗	
Tailgate hinges	⊗		⊗		⊗		⊗		⊗		⊗		⊗		⊗		⊗		⊗	
Seat belts: operation and strap damage	○		○		○		○		○		○		○		○		○		○	
Toe-in	○																			
Airbag system: visual inspection of airbag module/modules	○		○		○		○		○		○		○		○		○		○	
Road test (see separate road test programme)	○	○	○	○	○	○	○	○	○	○	○	○	○	○	○	○	○	○	○	



---

## **Saab Original Service Program M1994-96 USA Only 900 and 9000 Models**

A key component in building a positive long-term relationship with our Customer begins with the delivery process. Properly prepared vehicles for delivery to a retail customer conveys an image of a quality dealership, as well as a quality product.

Saab Cars USA, Inc. has pioneered the Dedicated Delivery Process and is recognized as an industry leader.

In today's environment it is absolutely vital that the delivery process is a special event for each and every customer. The customer perception of quality, value, caring and a professional organization can be directly related to the sales and delivery process.

Saab Cars USA, Inc. has in place a procedure called the PreDelivery Inspection (PDI) to ensure that all steps are taken to maximize our efforts to elevate our customer satisfaction and to reaffirm that Saab was the right choice.

### **Pre-delivery service**

The PDI Inspection (PDI) Control Form consists of two parts effective April 1, 1995. Part I should be filled out and completed by the receiving dealer within five days of delivery. Part II should be completed by the selling dealer as evidence that a final inspection was performed before the customer took delivery of the car.

The mechanical PDI includes:

- In-car operations
- Underhood inspection
- On-lift operations
- Audio system functions
- Road test

The final inspection includes:

- Checking SID unit
- Checking battery condition
- Removing interior protection
- Activating radio and function check
- Final clean-up

### **Time for Extra Work**

Time for extra work is not included in the basic PDI time (see Failure Code/Flat Rate Manuals for times). Extra work such as body/door hinge or latch adjustment, bulb replacement, battery charging, or replacement or repairs as a result of the test drive must be claimed separately.

### **Maintenance program**

The program consists of service measures that must be carried out to maintain the car's high standard of safety and prevent faults from arising. They are also designed to ensure that the car will conform to exhaust emission control regulations, maintain a high standard of roadworthiness and be economical in use.

A break-in "FIRST SERVICE" is provided free-of-charge at 5,000 miles. Normal services are then required at intervals of 10,000 miles thereafter (15,000; 25,000; 35,000 miles etc.).

It is the owner's responsibility to retain service records but it is the dealer's responsibility to fill out the record stub portion of the coupon that corresponds to the maintenance performed and stamp the coupon with the dealer's identification stamp. These coupons are located in the owner's Warranties & Service Record Booklet.

---

### **Important**

Inspection points and the replacement of consumable items which are subject to legal requirements should be carried out at the specified mileages only. These are marked with an asterisk \* in the service program.

---



# Saab Original Service Program M1994-96 USA, Canada

## 9000 Models

Service Interval\*\*  
Miles = U.S. Cars  
Kilometers = Canadian Cars

Service #1		5,000 (8000 km)	15,000 (24000 km)	25,000 (40000 km)	35,000 (56000 km)	45,000 (72000 km)	55,000 (88000 km)	65,000 (104000 km)	75,000 (120000 km)	85,000 (136000 km)	95,000 (152000 km)	105,000 (168000 km)
<b>Engine and engine compartment</b>												
E	Engine oil and filter (a.)	■	■	■	■	■	■	■	■	■	■	■
R	Engine coolant freezing point and level	○	○	○		○	○		○	○		○
R	Engine coolant flush and replace (max. 3-year intervals)				■			■			■	
R	Engine cooling system, hoses and cap	○		○	○	○	○	○	○	○	○	○
R	Drive belts; tension, Poly-Vee tensioner function and belt condition		○	○	○	○	○	■	○	○	○	○
R	Camshaft drive belt (V6)**				■			■			■	
E	Spark plugs				■*			■			■	
E	Evaporative emission system including filler cap, vapor lines, EVAP canister and canister purge valve							○				
R	Fuel system incl. tank: leaks and damage		○	○	○	○	○	○	○	○	○	○
E	Fuel filter							■				
E	Air cleaner element				■*			■			■	
R	Exhaust system and mountings; leaks and condition		○	○	○	○	○	○	○	○	○	○
<b>Electrical</b>												
R	Battery: check electrolyte level, clean and grease terminals	○	○	○	○	○	○	○	○	○	○	○
R	Headlamp and fog lamp alignment		○	○	○	○	○	○	○	○	○	○
R	Head, fog, brake, tail, turn signal, backup and marker lamps	○	○	○	○	○	○	○	○	○	○	○

\* For vehicles certified for sale and registered in California, these are the minimum required Emission Control System maintenance steps. Saab urges that all recommended maintenance procedures be performed according to this program.

(a.) Engine oil and filter should be changed at least once year. Intermediate oil and filter changes (halfway between indicated intervals) suggested for cars primarily used for driving in dense city traffic or for repeated short trip operation without sufficient engine warm up.

\*\*Camshaft drive belt replacements (V6) prior to 100,000 miles will be performed at no charge by an authorized U.S. or Canadian Saab dealer.

\*\*Service intervals: Repeat service procedures for Service #2 at 115,000/135,000 etc.; Service #7 at 125,000; Service #4 at 155,000/185,000

### Application/type of service (col. 1)

E = emission service  
R = regular maintenance

### Service Procedure

○ = check – top-up, adjust or replace if necessary  
■ = replace  
▲ = lubricate

# Saab Original Service Program M1994-96 USA, Canada

## 9000 Models

Service Interval\*

Miles = U.S. Cars

Kilometers = Canadian Cars

		5,000 (8000 km)	15,000 (24000 km)	25,000 (40000 km)	35,000 (56000 km)	45,000 (72000 km)	55,000 (88000 km)	65,000 (104000 km)	75,000 (120000 km)	85,000 (136000 km)	95,000 (152000 km)	105,000 (168000 km)
Service #1		1	2	3	4	5	6	7	8	9	10	11
<b>Transmission</b>												
R	Automatic transmission fluid and filter change (b.)	■			■			■			■	
R	Gearbox oil level (manual and automatic)	○	○	○	○	○	○	○	○	○	○	○
R	Outer and inner driver joint boots		○	○	○	○	○	○	○	○	○	○
<b>Chassis</b>												
R	Ball joint clearance, outer and inner steering joints and rubber boots		○	○	○	○	○	○	○	○	○	○
R	Front suspension, rear axle mountings; retighten	○										
R	Shock absorbers and bushes; tightness and condition				○			○	○	○	○	○
R	Tire pressure, tread depth and wear (c.)	○	○	○	○	○	○	○	○	○	○	○
R	Rotate tires, front to rear	○	○	○	○	○	○	○	○	○	○	○
R	Brake pads and discs; wear and condition	○	○	○	○	○	○	○	○	○	○	○
R	Brake lines and hoses	○	○	○	○	○	○	○	○	○	○	○
R	Brake fluid level and renewal (max.2-year intervals)	○	○	○	■	○	○	■	○	○	■	○
R	Power steering fluid level	○	○	○	○	○	○	○	○	○	○	○
R	Toe-in				○			○			○	
R	Ventilation air filter				■			■			■	
R	Door hinges, stops and locks				▲			▲			▲	
R	Airbag system, SRS warning lamps, visual inspection	○	○	○	○	○	○	○	○	○	○	○
R	Safety belts; operation and visual inspection of belt for tears and fraying	○	○	○	○	○	○	○	○	○	○	○
R	Wipers; clean glass & wiper blades, change blades if necessary	○	○	○	○	○	○	○	○	○	○	○
R	Washer system: check and top-up	○	○	○	○	○	○	○	○	○	○	○
<b>Road Test</b>												
R	Check performance of drive train, steering and brakes and verify tire balance. Check function of instruments and controls, including horn, windshield wipers, cruise control and climate system. Note any noises or problems for correction.	○	○	○	○	○	○	○	○	○	○	○

(b.) Change automatic transmission fluid and clean filter at more frequent intervals (20,000; 50,000; 8000 miles, etc.) if car is driven in dense city traffic where the outside temperature regularly reach 90°F or higher, or if car is used in a mountainous/high altitude area or for trailer towing.

(c.) Check wheel alignment if irregular or premature tire wear is apparent.

## Pre-delivery service

### Washer fluid

Top up the washer fluid reservoir with washer fluid and water (in accordance with the recommendations on the packaging).

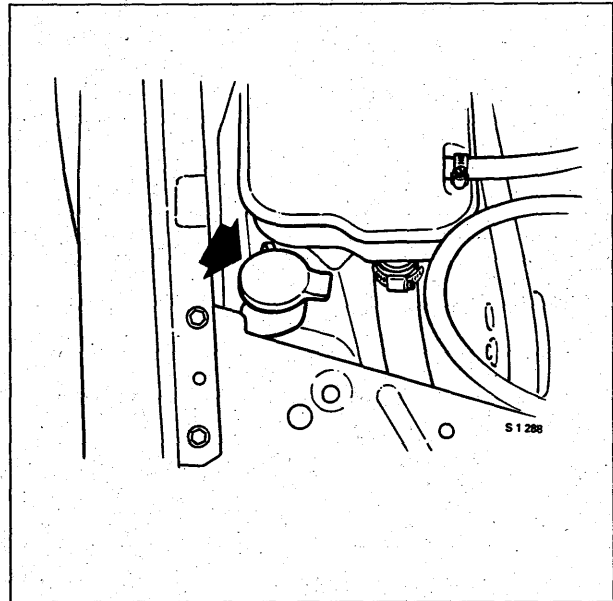

### Interior equipment

Insert the fuses for the power aerial/radio/anti-theft alarm, interior lighting/central locking system and clock.

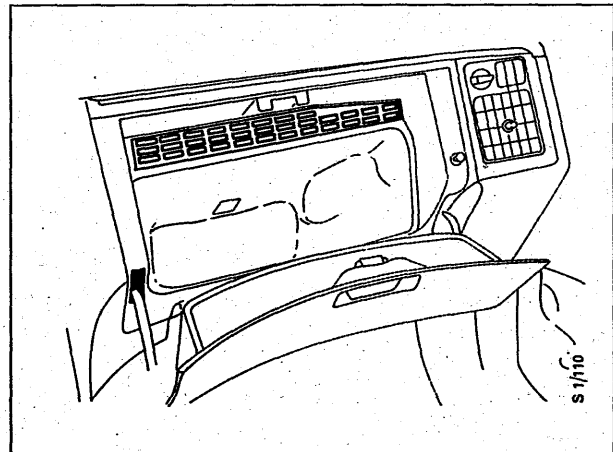



### Electrically adjustable seats with memory:

Fit the relay for the memory logic. It is packaged and placed in the compartment between the front seats.

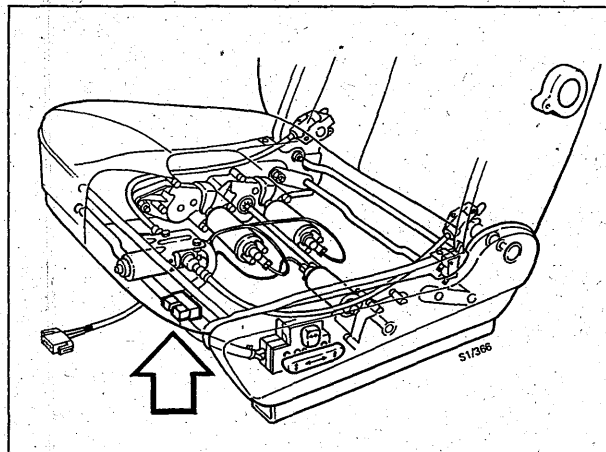

Relay location

### Dashboard

Check:

- Warning and indicator lamps with ignition switch in Test position
- Horn
- Cigarette lighter
- Instrument lighting
- Clock (set to correct time)

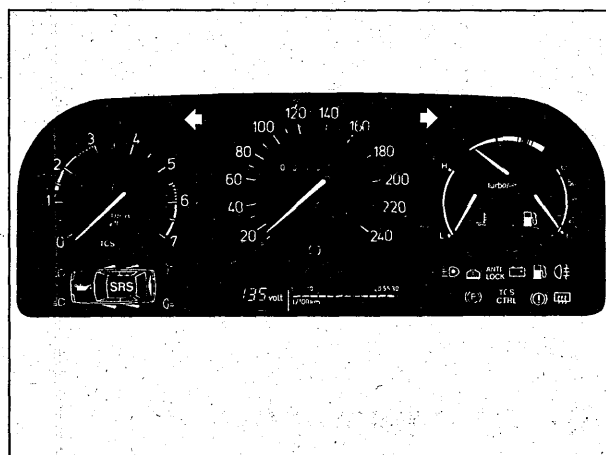

## Programming the anti-theft alarm

### Affixing the labels

Labels should be affixed to both the remote control units for cars equipped with an anti-theft alarm. Select the right label for the relevant market and affix it to the flat surface on the remote control units.

Not applicable to US/CA.

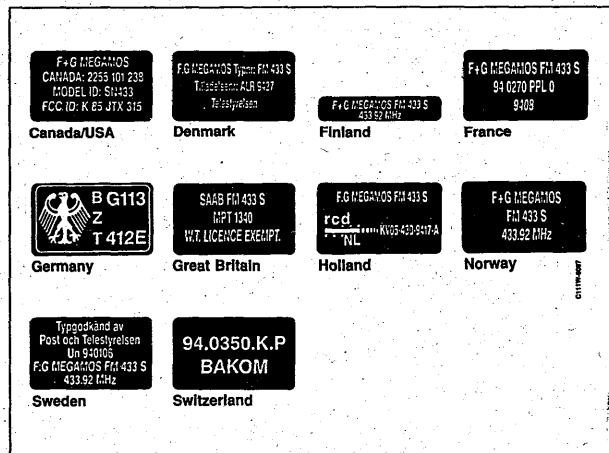
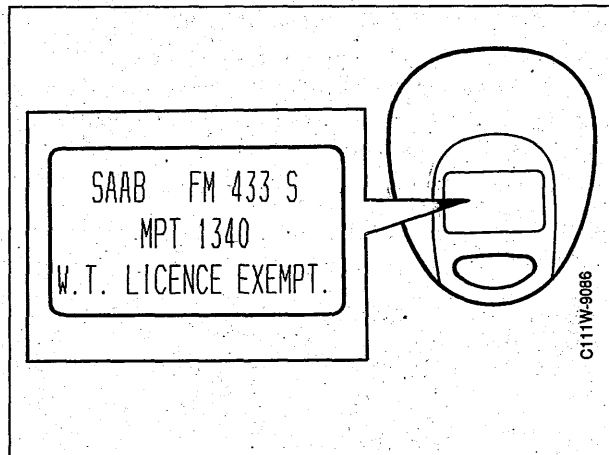

Labels supplied with the remote control units

### Swedish market

For the Swedish market, the following labels should be affixed in addition to those described above, see illustration.

Affix the SSF labels as shown, one on the windscreen and one on each front door window.

Affix the ATA label to the inside of the cover for the storage compartment between the front seats.

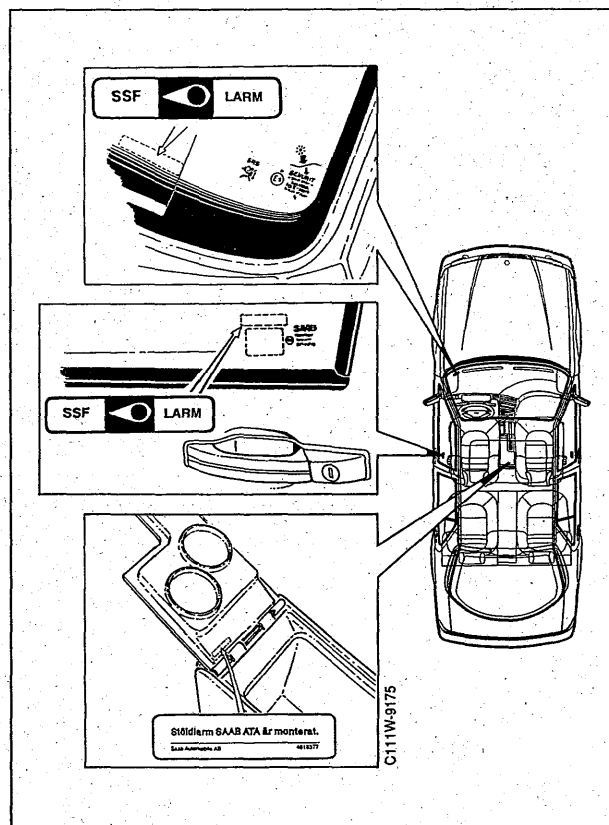

**Basic programming of the anti-theft alarm**

If the car is equipped with a factory-fitted anti-theft alarm, basic programming of the alarm should be carried out in accordance with the table below, using an ISAT scan tool.

○ = factory-programmed function

X = reprogramming to be carried out in conjunction with pre-delivery service

**Programming in conjunction with pre-delivery service**

ISAT scan tool command			Market							
PROGRAMMING			SE	D	GB	NL	CH	BE	FR	Other
	Horn	Direction indicators								
COUNTRY CODE, select										
GERMANY	30 s intermittent	5 min flashing	○	○	○	○	○	○	○	○
GREAT BRITAIN	30 s intermittent	no flashing			X					
SWITZERLAND	30 s continuous	no flashing					X			
OWN CHOICE										
HOLLAND	30 s continuous	5 min flashing				X				
SIREN (always select if included)										
REMOTE CONTROL PROGRAMMING			○	○	○	○	○	○	○	○
SELF-ACTIVATION										
OFF			○	○	○	○	○	○	○	○
IF +15 OFF										
IF +15 OFF, DOOR CLOSED					○			○		
TIME BEFORE ACTIVE (s = sec.)					30s			30s		
SELF-IMMOBILIZATION, select										
TIME BEFORE ACTIVE (s = sec.)				30s		30s			30s	
FLASH/BEEP:										
ORIGINAL SETTING (Direction indicators)	activate	1 flash	○	○	○	○	○	○	○	○
	deactivate	3 flashes								
	activate	1 beep			○					○
	deactivate	2 beeps								
	release luggage compartment	2 s flash	○	○	○	○	○	○	○	○
		3 beeps		○	○	○	○	○	○	○
SIREN										
OFF			○	○	○	○	○	○	○	○
ON (select if siren fitted)										
PROGRAMMING			SE	D	GB	NL	CH	BE	FR	Other

### Basic programming of anti-theft alarm (US, PA and JA markets)

On cars equipped with an anti-theft alarm, basic programming of the alarm should be carried out in accordance with the table below, using an ISAT scan tool.

#### Programming in conjunction with pre-delivery service

○ = factory-programmed function

X = reprogramming to be carried out in conjunction with pre-delivery service

ISAT scan tool command			Market		
			US	PA	JP
PROGRAMMING					
	Horn	Direction indicators			
COUNTRY CODE, select					
GERMANY	30 s intermittent	5 min flashing	○	○	○
GREAT BRITAIN	30 s intermittent	no flashing			
SWITZERLAND	30 s continuous	no flashing			
OWN CHOICE					
HOLLAND	30 s continuous	5 min flashing			
SIREN (always select if included)					
REMOTE CONTROL					
PROGRAMMING			○	○	○
SELF-ACTIVATION					
OFF			○	○	○
SELF-IMMOBILIZATION, select:					
OFF			○	○	○
ON					
TIME BEFORE ACTIVE (m = minutes)					
ACTIVATION TIME (m = minutes)					
FLASH/BEEP:					
ORIGINAL SETTING (Direction indicators)	activate	1 flash	○	○	○
	deactivate	3 flashes			
	activate	1 beep	○	○	○
	deactivate	2 beeps			
	release luggage compartment	2 s flash		○	○
		3 beeps		○	○
DEACTIVATION, LOCK					
OFF					
ON			○	○	○
DISCONNECTION, LUGGAGE COMPARTMENT					
OFF					
ON			○	○	○
SIREN					
OFF			○	○	○
ON (select if siren fitted)					
PROGRAMMING			US	PA	JP

## Clear diagnostic trouble codes (only USA, Canada)

OBD II specification cars:

Plug in an ISAT scan tool.

Clear any engine management system and automatic transmission diagnostic trouble codes.

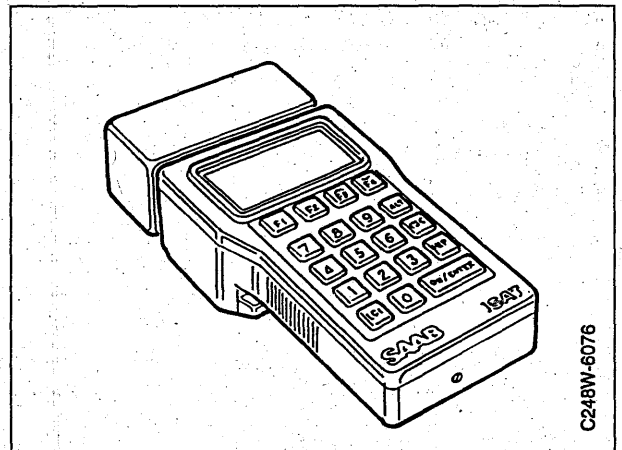

## Programming the ACC unit

Where fitted, the ACC unit must be reprogrammed from OFF to AUTO (the transport safety devices should be fitted in place).

- Turn the ignition switch to the ON position. The ACC unit will display OFF.
- Reprogram the unit by simultaneously pressing the AUTO and OFF buttons. The ACC unit will now display AUTO.
- Turn the ignition switch to the OFF position.

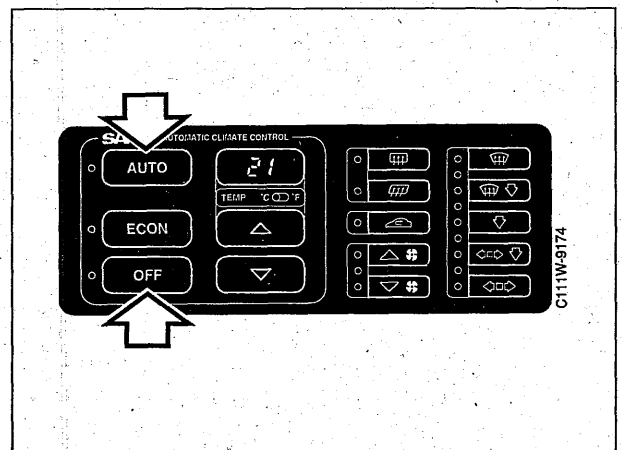

## Radio

- 1 Switch on the radio. The display will show CODE IN.
- 2 Enter the correct code on the six preselect buttons.  
If you enter the wrong code, it will appear in the display.  
In such case, press the BAND button for more than three seconds. The display will show CODE IN again.  
Enter the correct code.

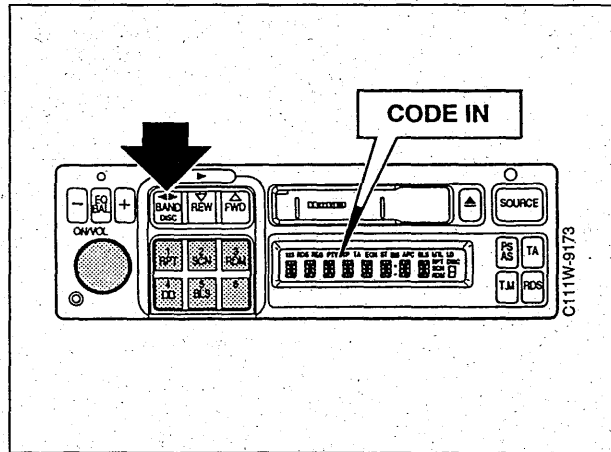

### Important:

If you enter the wrong code three times in succession, the display will again show CODE IN and you will then have to wait one hour with the radio switched on before you can make a fresh attempt.

## Wipers and washers

Check the windscreen and headlamp washers and wipers and adjust the nozzles if necessary. Also check the rear window wash-wipe system, if fitted.

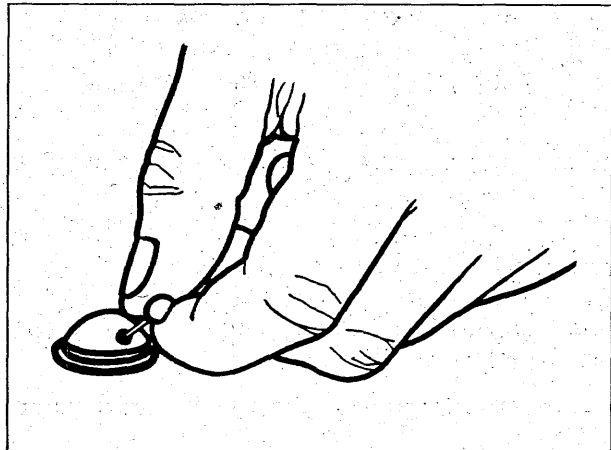

## Tyres

Tyre size	Number of occupants	Speed km/h (mph)	front		rear	
			bar (psi)	bar (psi)	bar (psi)	bar (psi)
195/65 R15 91T/H/V	1-3	0-160 (0-100)	2.1 (30)	2.1 (30)	2.1 (30)	2.1 (30)
205/55 ZR16	1-3	0-190 (0-120)	2.4 (35)	2.4 (35)	2.4 (35)	2.4 (35)
205/60 ZR15	1-3	0-190 (0-120)	2.2 (32)	2.2 (32)	2.2 (32)	2.2 (32)

### Spare wheel

T115/70 R16	4.2 (60)
175/70 R15 T	2.5 (36)

For other tyres, speeds and loads, see Service Manual 0 "Technical data".

## Wheel bolts, pressed steel and light alloy wheels

Retighten the wheel bolts to a torque of:  
 117 Nm (86 lbf ft) - light alloy wheels  
 100 Nm (74 lbf ft) - pressed steel wheels

### Important:

Always use a torque wrench to retighten the wheel bolts to the correct torque.

When fitting **new light alloy wheels** for the first time, tighten the bolts to a torque of 125-145 Nm (92-107 lbf ft).

Fit the hub caps.

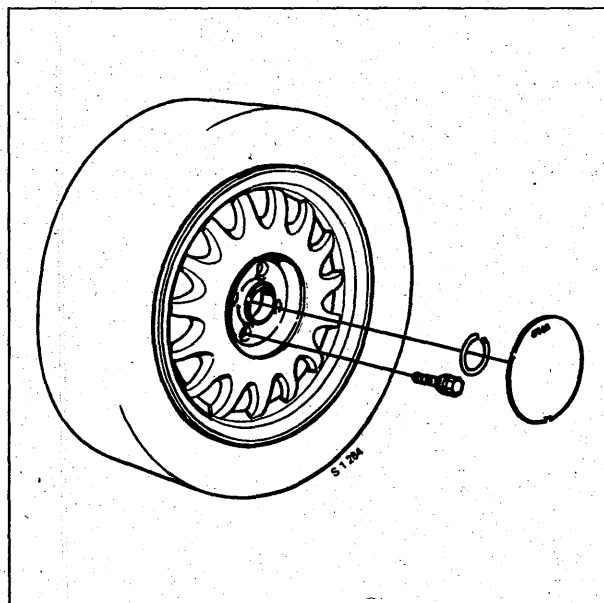

## Oil level, engine

Check the level while the engine is still warm, 2-5 minutes after switching off.

Top up with oil to the MAX mark on the dipstick. The distance between the MAX and MIN marks corresponds to one litre (1.05 qts).

### Grade of oil:

Saab Turbo motor oil or oil to API SG and CCMC G4/G5 specification. These oils contain suitable additives for the engine.

We advise against the use of additional additives.

### Viscosity:

SAE 10W-30, 10W-40, 5W-30 or 5W-40. If these viscosities are unobtainable, 15W-40 oil may be used but not during the winter.

In countries where the temperature never falls below +15-20°C, oil having a viscosity of 15W-50 or 20W-50 is recommended.

If 5W oils are used, they must be of fully-synthetic or semi-synthetic type.

In markets where the only 5W oil obtainable is of mineral type, such oil may be used provided that it meets the standards of quality specified above.

### WARNING

Make sure that the filler cap (1) is screwed down hard after topping up with oil. Oil on the exhaust manifold could cause a fire.

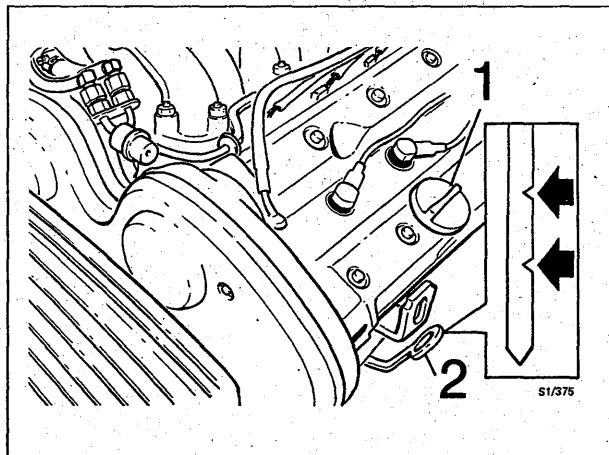
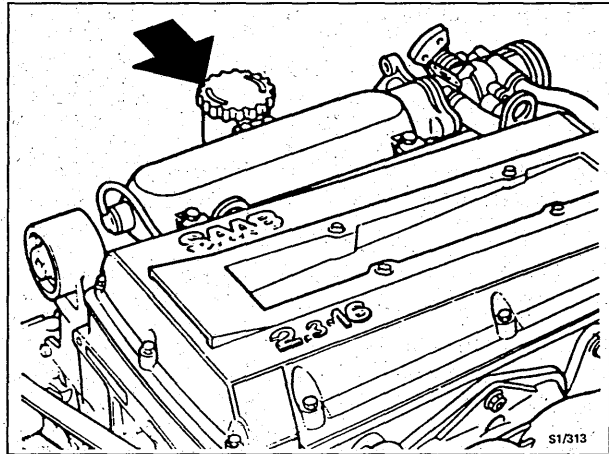

B308

- 1 Filler cap
- 2 Dipstick



## Fluid level, automatic transmission

Start the engine and run it at idling speed. Engage D and wait at least 15 seconds. Then engage R and wait another 15 seconds. Repeat in position P.

Check the fluid level (engine running at idling speed and selector lever in P). Top up as necessary.

---

### Important:

The dipstick has two sets of level marks. The amount of fluid between the maximum and minimum marks is about 0.4 litres (0.4 qts).

---

### Grade of fluid (not ME):

DEXRON II automatic transmission fluid.

### Grade of fluid (ME only):

DEXRON IIE automatic transmission fluid.

## Fluid level, power steering

Check the level and top up as necessary. If the fluid level is low, investigate the cause.

### Grade of oil:

Saab Power Steering Fluid 4634, part No. (45) 30 09 800 - 0.75 litres.

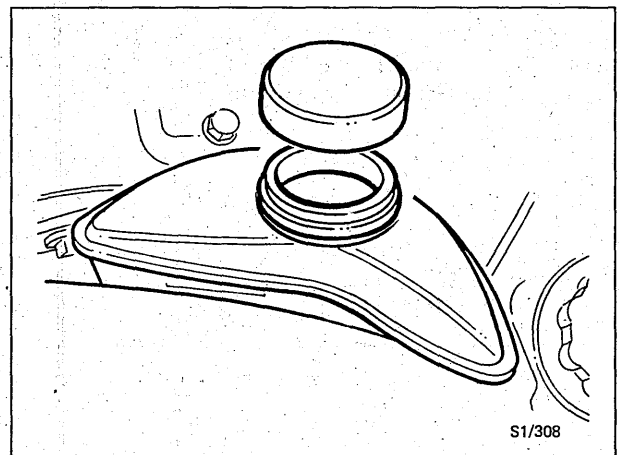
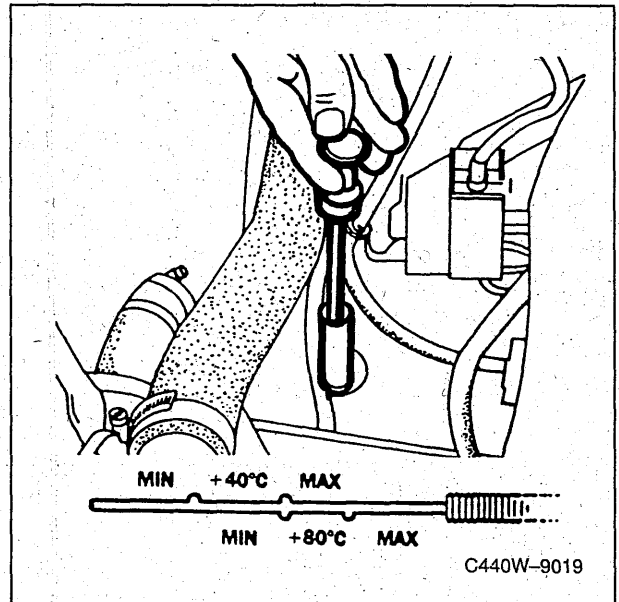

## Coolant level

Check the level and top up as necessary with equal amounts of SAAB Original Coolant and water (half and half).

**Important:** This mixture also provides effective corrosion protection.

Avoid mixing different types of coolant.

Do not fill up above the MAX mark.

In the event of loss of coolant, investigate the cause.

---

### Important:

Screw the filler cap down hard or the system will not be pressurized, resulting in a lower boiling point and loss of coolant.

---

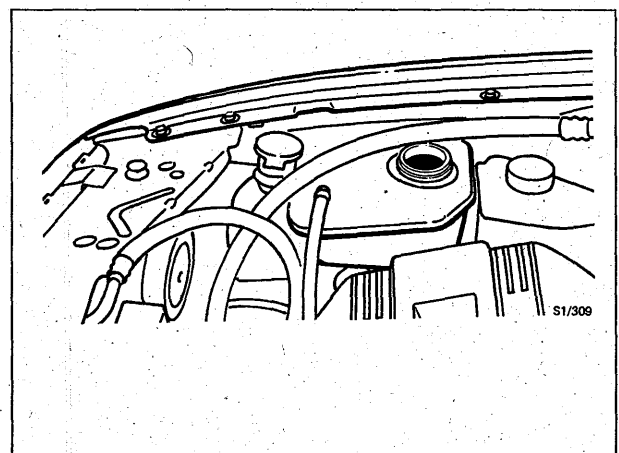

## Fluid level, brakes and clutch

Check the level and top up as necessary.

### Brake fluid:

Grade: to DOT 4 specification.

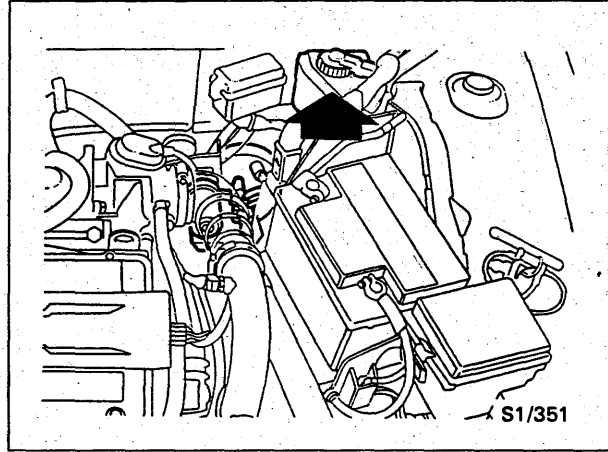

## Boost pressure control valve (Turbo only)

Plug the connector into the boost pressure control valve.

### Important:

OBD II related function.

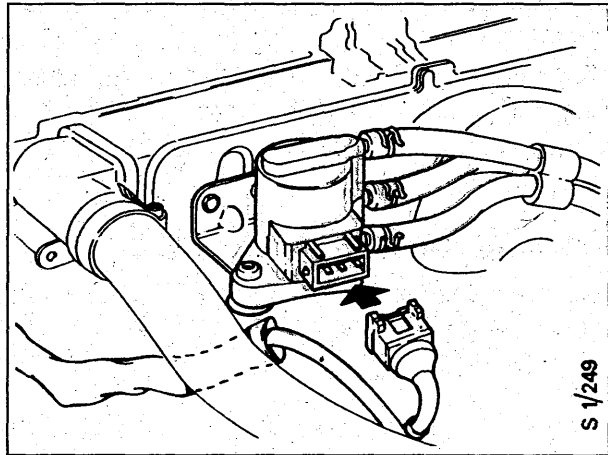

## Underbody

Raise the car and inspect it for possible transit damage to the brake system, suspension, exhaust system and underbody.

Note: Corrosion protection should be intact.

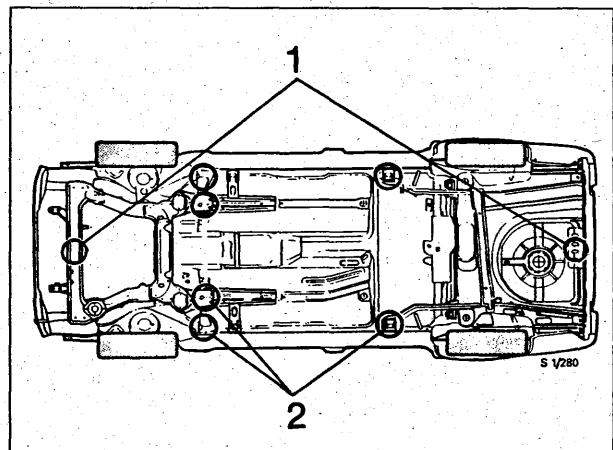

- 1 Lifting points for garage jack.
- 2 Lifting points for car lift.

## Retightening the front assembly joints

Tighten the indicated bolts to the prescribed torque.

MacPherson strut to body  
47 Nm (35 lbf ft).

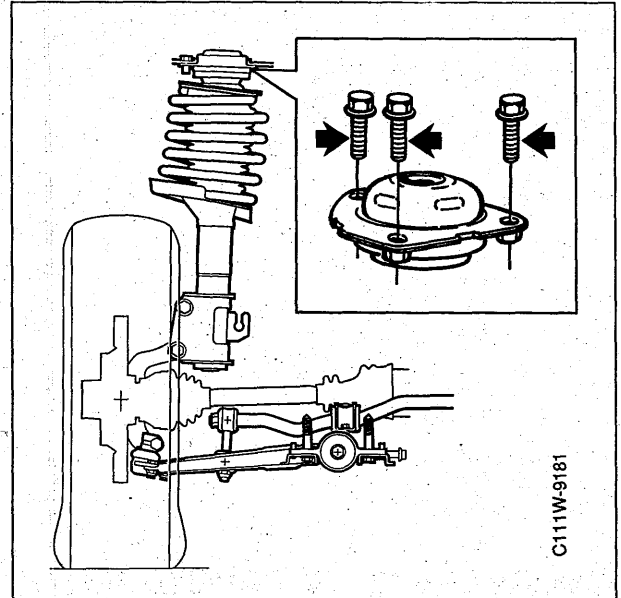

---

### Important:

Never overload the bolts in a joint by tightening them harder than to the specified torque.

---

## Transit safety fasteners

Remove the fasteners. Withdraw the cotter pin and remove the fastener on each side of the car.

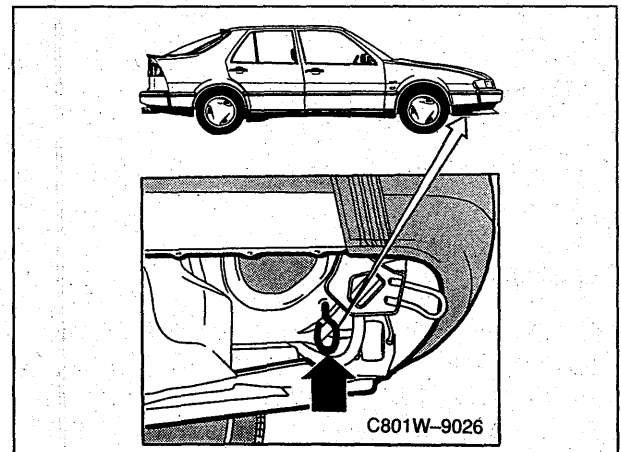

## Equipment

Fit all loose equipment packed in the delivery box.  
The contents of the box may vary, depending on the market and model variant.

- Number plate holder
- Mounting kit for number plate holder
- Speed-warning system (ME)
- Jack protector
- Plastic bag for spare wheel
- Fog lights
- Mounting kit for stone chip guards
- Mounting kits for spoilers
- Fitting of high-level brake light
- Mounting kit for air deflector and spoiler panels
- Bolts
- Tools
- Gloves
- Touch-up paint (USA)
- Mounting plate for child safety seat (CA)

---

### Important:

When fitting blanking-off covers to the apertures for extra lamps in the front spoiler, drill the holes **before** fitting the spoiler.

---

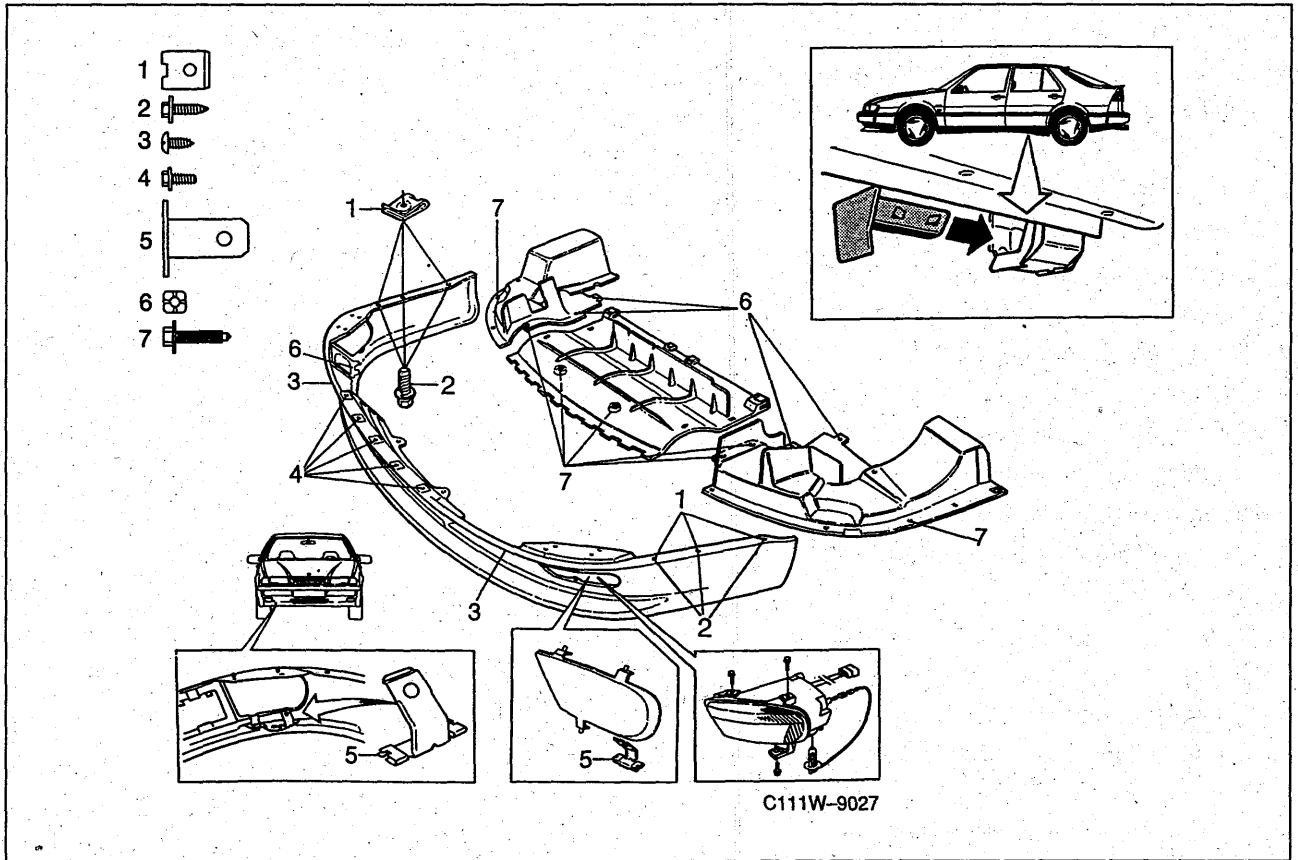

9000 CS

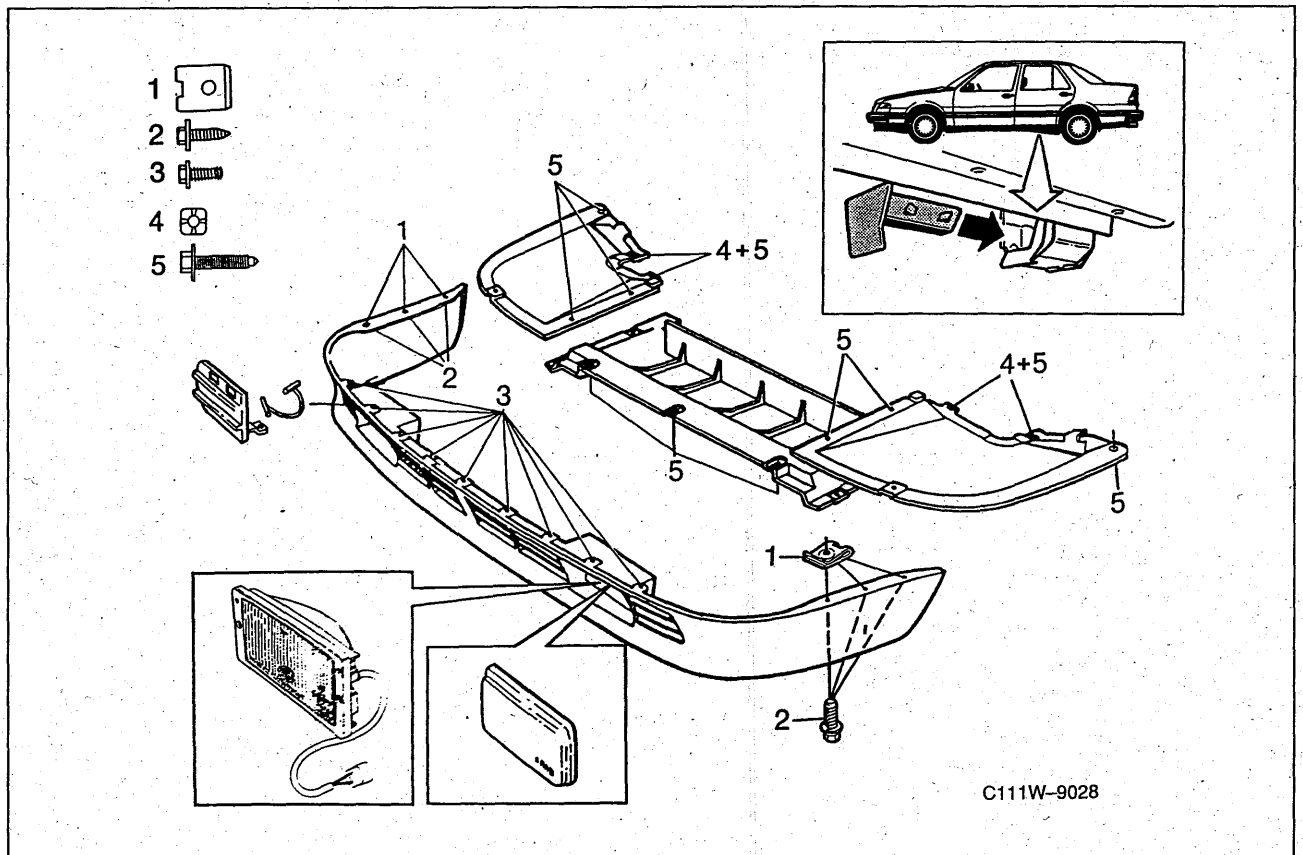

9000 CD

**Fog lights, 9000 CD (M1994)**

- 1 Undo the surround and remove the lens insert.
- 2 Fit the three bushes in the housing.
- 3 Fit the three adjusting screws in the spoiler.
- 4 Press the housing onto the adjusting screws.
- 5 Fit the lens insert and surround.
- 6 Plug in the connector.
- 7 Fit the other fog light in the same manner.
- 8 Adjust and align the fog lights.

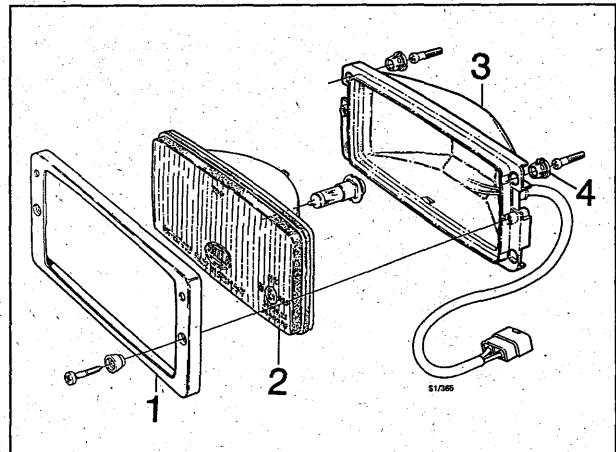

- 1 Surround
- 2 Lens insert
- 3 Housing
- 4 Bush

**Fog lights, all 9000 CS and 9000 CD M1995-****Fog light alignment**

The adjusting screw for fog light alignment is accessible through a hole in the spoiler undersection.

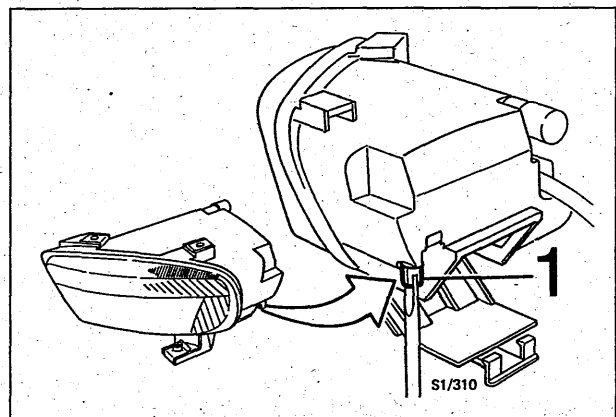

1 Adjusting screw for fog light alignment, 9000 CS

**Blanking-off covers in front spoiler, all 9000 CS and 9000 CD M1995-**

On cars not fitted with fog lights, the blanking-off covers and clips supplied should be fitted. To ensure that the blanking-off covers stay in place, it is important to fit the clips as shown.

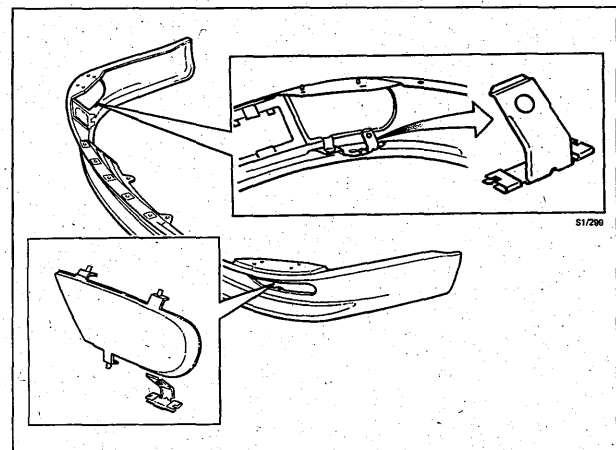

### Air deflector

Use a knife to cut the deflector as shown on the label. The different areas to be cut away are shown in the Fig.

1. Cars having a 20 dm<sup>2</sup> radiator **without** an oil cooler for the **automatic transmission**.
2. Cars having a 16.7 dm<sup>2</sup> radiator.
3. Cars having a 20 dm<sup>2</sup> radiator **with** an oil cooler for the **automatic transmission**.

A = 20 dm<sup>2</sup> radiator  
 B = 16.7 dm<sup>2</sup> radiator

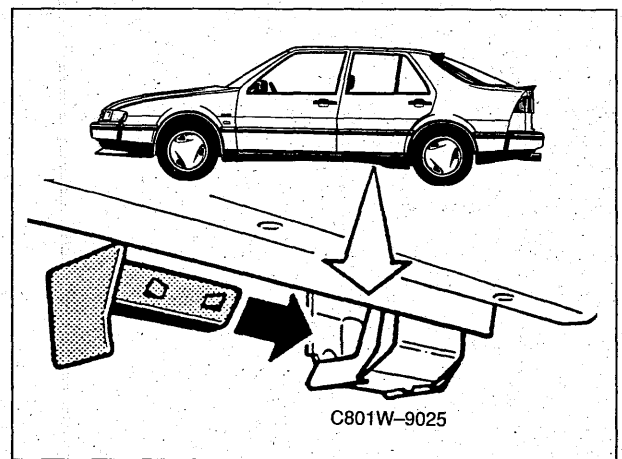
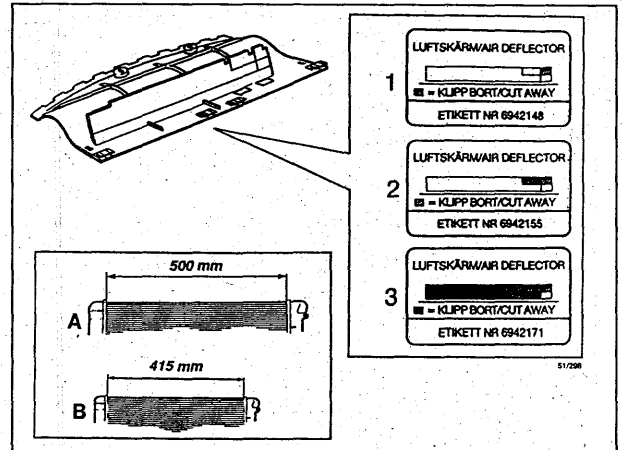

Fitting the stone chip guards

### Certificate of Conformity

Cars for the European market: In the spare wheel well is a "Certificate of Conformity". Fold this document and place it in the plastic pocket at the back of the car's Service Logbook on the inside.

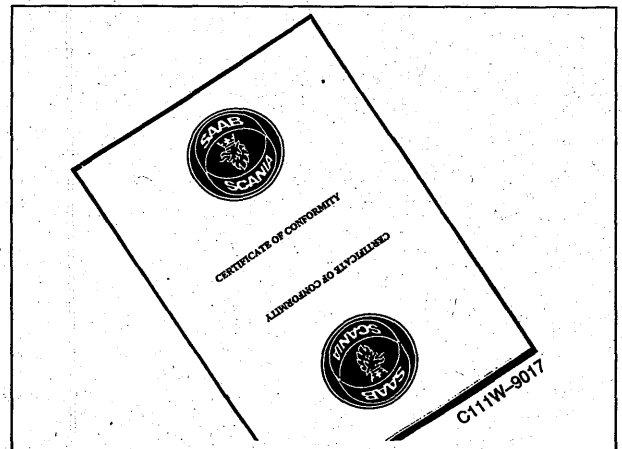

## Road test

The road test is an important part of the service programme. Check the various functions as described below.

OBD II specification cars: Check that there are no remaining faults which could cause the CHECK ENGINE lamp (MIL) to light up.

- Road testing should continue for at least 15 minutes at varying engine loads and speeds.
- Finish the road test by running the engine at idling speed with the selector lever in the N position and without any load from the A/C compressor or generator (all current-consuming components and A/C switched off) for 30-60 seconds.

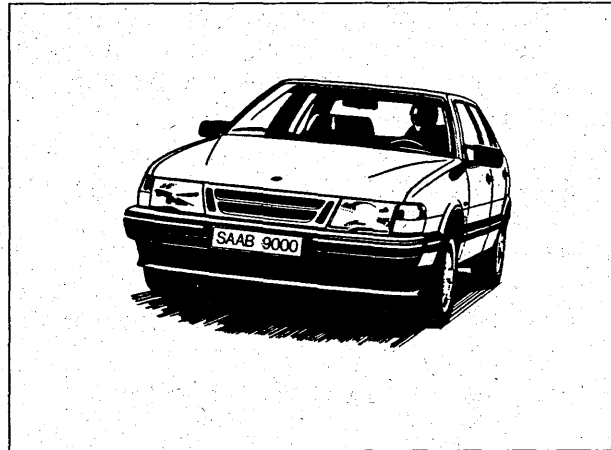

## Function checks

- Ignition switch  
Check that the steering-column lock operates satisfactorily and that the key is easy to insert and remove.
- Check the Parking position lock on cars with automatic transmission (certain markets only)
- Engine  
Operation and noise level. Turbo: check that boost pressure is normal during acceleration (needle moves up to the red zone).
- Clutch  
Check the positions of the pedal at which the clutch disengages and begins to engage.
- Manual gearbox  
Check gearbox operation and noise level.
- Automatic transmission  
Check the selector lever detent, noise level and shifting performance.
- Wheels  
Check wheel balance and wheel roundness.
- Steering  
Check the straight-ahead position of the steering wheel, directional stability and operation of the power steering system.
- Instruments and indicator lamps  
Check the operation of instruments and indicator lamps.
- Brakes  
Check brake pedal travel, handbrake lever travel (4-5 notches), and the efficiency of the brakes and handbrake.
- Cruise Control  
Check the operation of the Cruise Control system.



- **Climate control system**  
Check the operation of the A/C system and the heating and ventilation system, and their controls. When the outdoor temperature is so low that the A/C system cannot be turned on, check the operation of the system indoors.
- **Inspect the surface of the steering wheel centre pad (airbag module) and passenger airbag, if fitted, for external damage.**
- **Wipers and washers**  
Check the washer jet pattern and wiper operation on the windscreen and, if relevant, the rear window.
- **Check that the clock shows the right time.**

**Bear in mind what the customer might think!**

Wipe the steering wheel and gear lever clean and make sure that all other traces of pre-delivery inspection and service work have been removed.

### **Clear diagnostic trouble codes (only USA, Canada)**

OBD II specification cars:

Plug in an ISAT scan tool.

Clear any engine management system and automatic transmission diagnostic trouble codes.

Take remedial action as necessary.

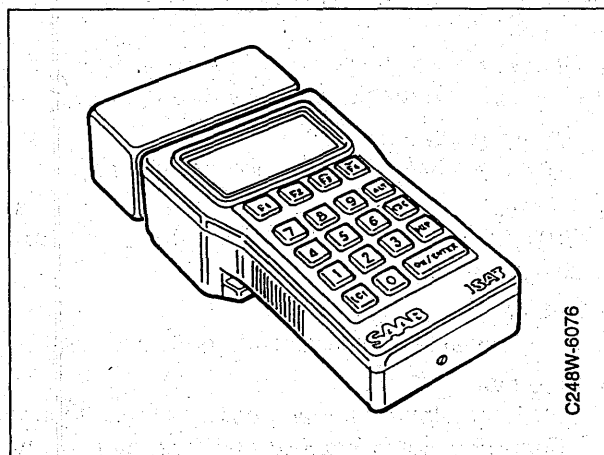

## Cleaning

### **WARNING**

#### **Safety information**

Make sure the premises are well ventilated. Avoid getting any liquid on your skin or mucous membranes.

Wear gloves. It is also advisable to wear goggles.

It is strictly forbidden to apply detergent with a spray gun, as this produces a mist.

Never store detergent in a bottle or other container without a label giving details of the manufacturer and type of detergent.

#### **Remedial action if detergent gets in your eyes**

Wash out the detergent immediately.

Hold your eyelids apart as much as possible.

Rinse your eyes with copious amounts of water for at least 15 minutes.

Then see a doctor as soon as possible.

#### **Poisonous substance**

If someone has swallowed detergent and is still conscious:

Get them to drink large quantities of water or two or more glasses of milk.

Do **not** make them vomit.

Call a doctor immediately.

#### **Remedial action if detergent gets on your bare skin**

Take off any items of clothing that have been splashed with detergent.

Wash the affected parts of your skin with soap and generous amounts of water.

## **Washing - dewaxing**

The protective film for the paintwork (paint protector) must be removed by dissolving it with a special detergent, Tempro 75 Remover.

## **Materials**

- Tempro 75 Remover
  - 10 litres - (45) 30 02 482
  - 25 litres - (45) 30 02 490
- High-pressure power washer
- Spray gun

Consumption per car wash is about 0.3-0.5 litres of concentrated Tempro 75 Remover, equivalent to about 3-5 litres of diluted detergent.

### Instructions for use

---

**Important:**

Tempro 75 Remover is a high-alkaline product (high pH). It should be used only on bodywork surfaces to which paint protector has been applied.

---

- 1 Dilute Tempro 75 Remover with hot water to a concentration of 2-4%.  
If water at a lower temperature is used to rinse off Tempro 75 Remover and the paint protector (see point 5) the concentration should be higher, but not more than 15% at most.
- 2 Flush loose dirt off the car with a high-pressure power washer.
- 3 Wet all parts of the bodywork covered by paint protector with Tempro 75 Remover, using a spray gun or the high-pressure power washer. The car should be at room temperature to ensure that the paint protector will be dissolved.
- 4 Allow Tempro 75 Remover to act for about three minutes. Note that it must not be allowed to dry. If it does, apply additional Tempro 75 Remover.
- 5 Rinse off the Tempro 75 Remover and paint protector with a high-pressure jet of hot water (but not hotter than +60°C).
- 6 Remove any remaining paint protector using a sponge and Tempro 75 Remover.
- 7 Wash the car, using a car shampoo.

## Final dismantling and finishing measures

- 1 Use concentrated washer fluid to clean all the windows and remove all residual grease from the windscreen and wiper blades.

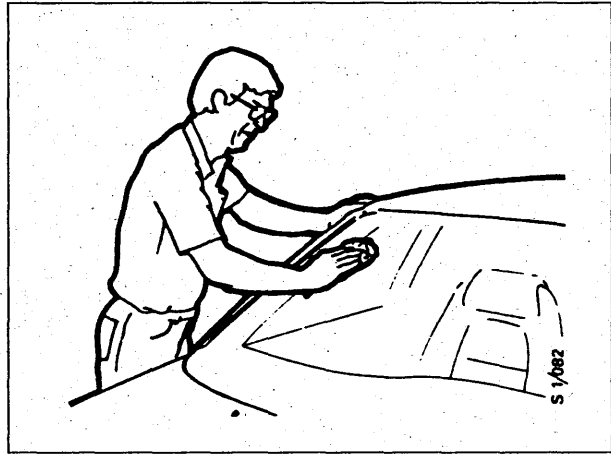

- 2 Remove the in-transit and in-storage protection from the bumpers, doors, floor and seats. Inspect the interior for stains and remove any that you find.

### WARNING

The protective plastic **must** be removed before the car is handed over to the customer as protective plastic in the car does **not** meet the requirement of inflammability (legal requirement).

Remove any spots and stains on the upper horizontal surface of the dashboard with a lukewarm soap solution. Rinse the surface with clean water before drying it.

### Important:

Vinyl sprays and the like must never be used as they could be the cause of a film forming on the windscreen and seriously reducing visibility.

- 3 Clean rubber mouldings, tyre sidewalls and bumpers.
- 4 Inspect the car, remove spots and stains. If necessary, polish the car.

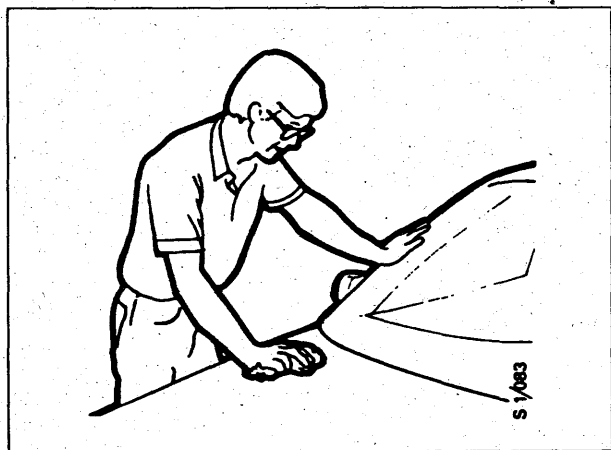



## Saab Original Service

### Lighting (headlamps, light clusters, other lights)

Check the front and rear lighting systems, direction indicators, brake lights, high-level brake light, reversing lights, rear fog light and number plate lighting.

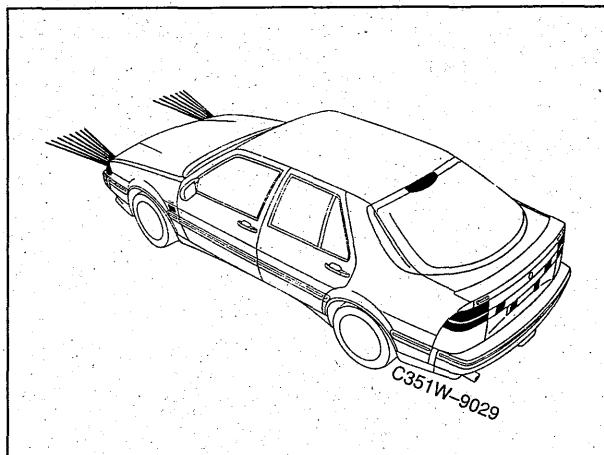

### Indicator and warning lamps

Turn the ignition switch to the Test position and check that the indicator and warning lamps light up as shown. Check the pictogram when doors and tailgate are open.

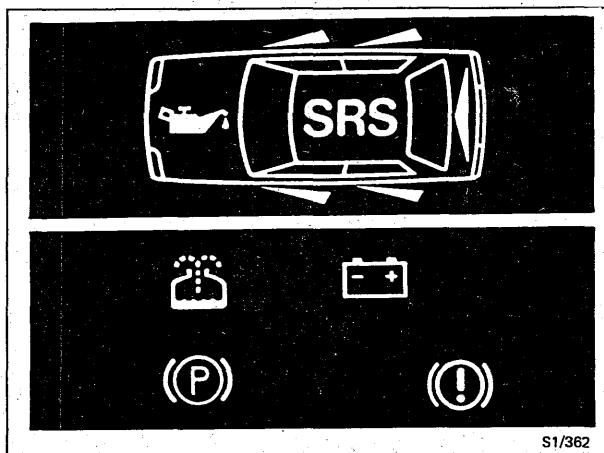

### Headlamps and fog lights

Check the condition and alignment of the headlamps and fog lights.

**Important:**

If the car is equipped with a headlamp beam adjustment switch, always set the switch to 0 before checking and adjusting headlamp alignment.

**Before adjustment:**

- Check that all tyres are inflated to the correct pressure.
- Make sure there is no luggage in the car.
- Check the amount of fuel in the tank.  
Compensate by placing a load in the luggage compartment:  
    tank half full - 25 kg  
    tank empty - 50 kg
- Position the car on a level surface.

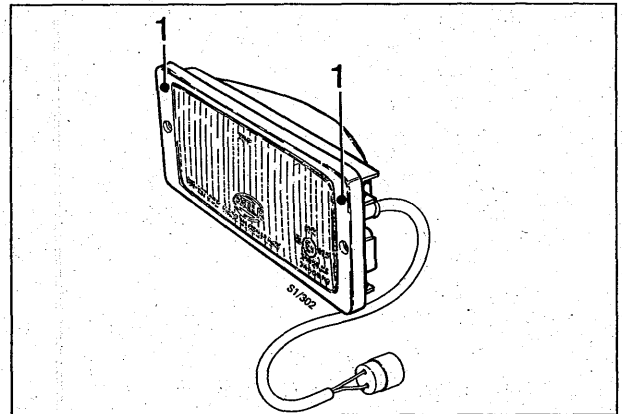
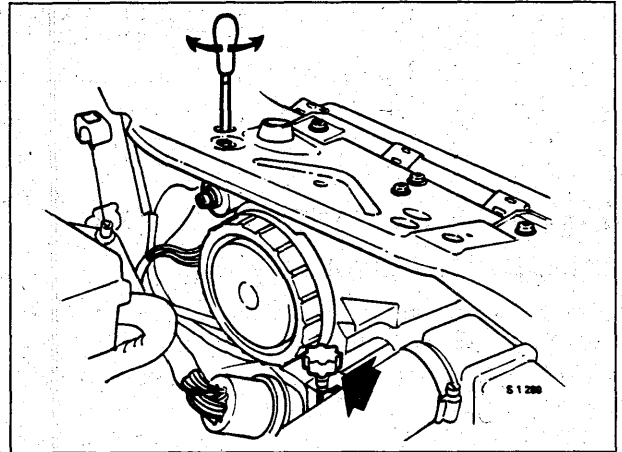

1 Adjusting screws for fog-light alignment, 9000 CD

- 9000CS and 9000CD M1995-: The adjusting screw for fog-light alignment is accessible through a hole in the spoiler undersection.

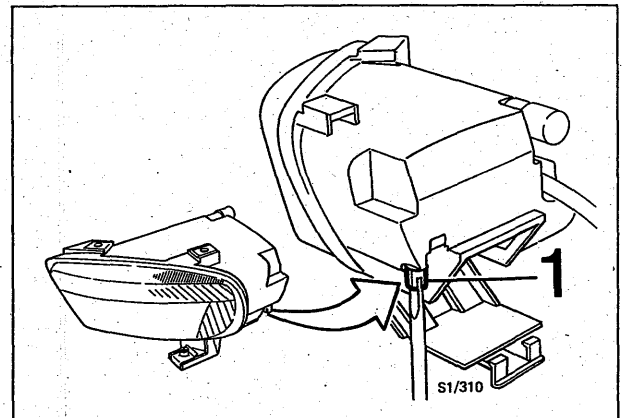

1 Adjusting screw for fog light alignment, 9000 CS

## Check for oil leakage

Check that no oil leakage occurs at the top or bottom of the engine/gearbox or in the power steering's hydraulic system.

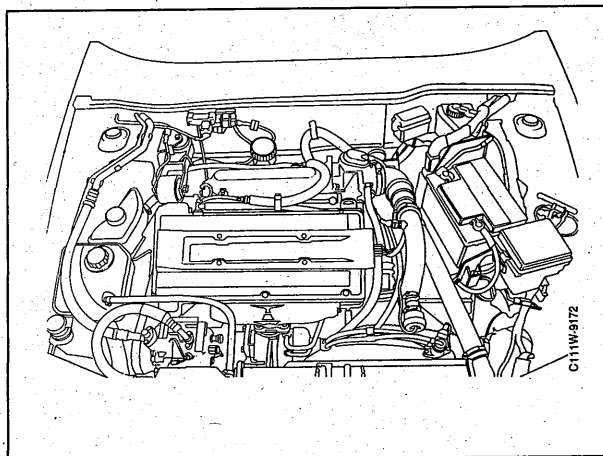

## Engine oil change

### Oil capacities

B204, B234: 4.7 litres (5.0 qts) including filter  
 B308: 4.5 litres (4.7 qts) including filter.

### Grade of oil:

Saab Turbo motor oil or oil to API SG and CCMC G4/G5 specification. These oils contain suitable additives for the engine.

We advise against the use of additional additives.

### Viscosity:

SAE 10W-30, 10W-40, 5W-30 or 5W-40. If these viscosities are unobtainable, 15W-40 oil may be used but not during the winter.

In countries where the temperature never falls below +15-20°C, oil having a viscosity of 15W-50 or 20W-50 is recommended.

If 5W oils are used, they must be of fully-synthetic or semi-synthetic type.

In markets where the only 5W oil obtainable is of mineral type, such oil may be used provided that it meets the standards of quality specified above.

### Drain plug

#### Tightening torque:

**B204, B234: 27 Nm (20 lbf ft)**  
**B308: 55 Nm (41 lbf ft)**

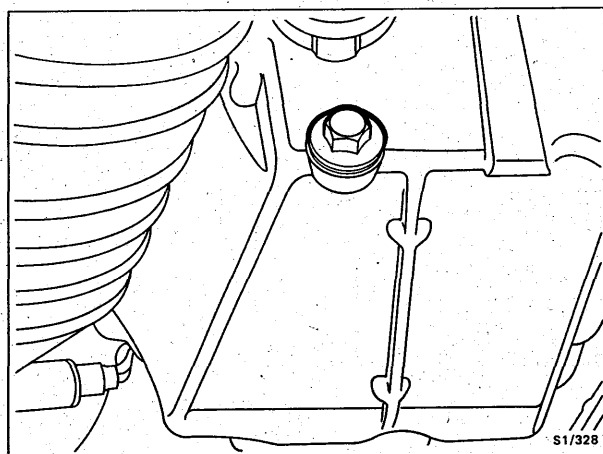

B204, B234

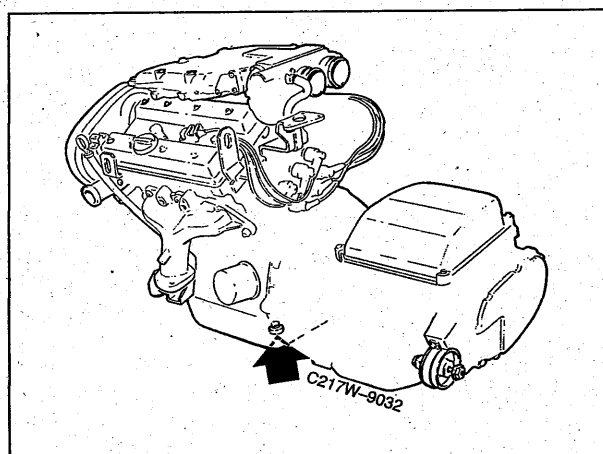

B308

### WARNING

Make sure that the filler cap is screwed down firmly after topping up with oil. Oil on the exhaust manifold could cause a fire.



## Oil filter change

- 1 Loosen the filter cartridge using a filter wrench and unscrew the filter. Wipe the mating surface on the engine clean.
- 2 Oil the rubber gasket on the new filter cartridge and screw the cartridge in place.

**Tightening torque: 10 Nm (7.4 lbf ft)**

- 3 Start the engine and check the filter for leaks.

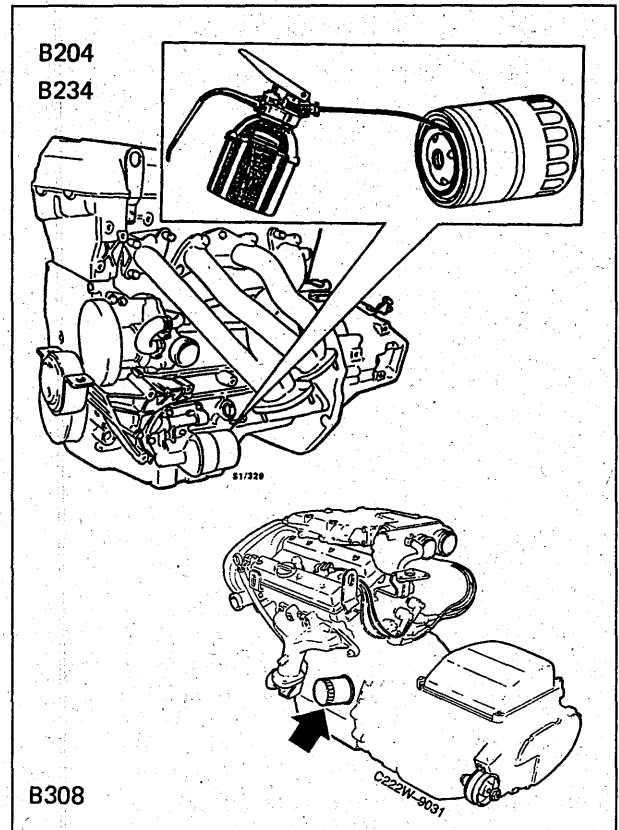

## Automatic transmission

Change the fluid in the automatic transmission  
Change the filter element.  
Change O-rings.

Fluid capacity: 3.0-3.5 l (3.1-3.7 qts)

**Grade of fluid (not ME):**

DEXRON II automatic transmission fluid.

**Grade of fluid (ME only):**

DEXRON IIE automatic transmission fluid.

Remove the drain plug so that all the fluid will run out of the transmission.

**Drain plug**

**Tightening torque: 8 Nm (5.8 lbf ft)**

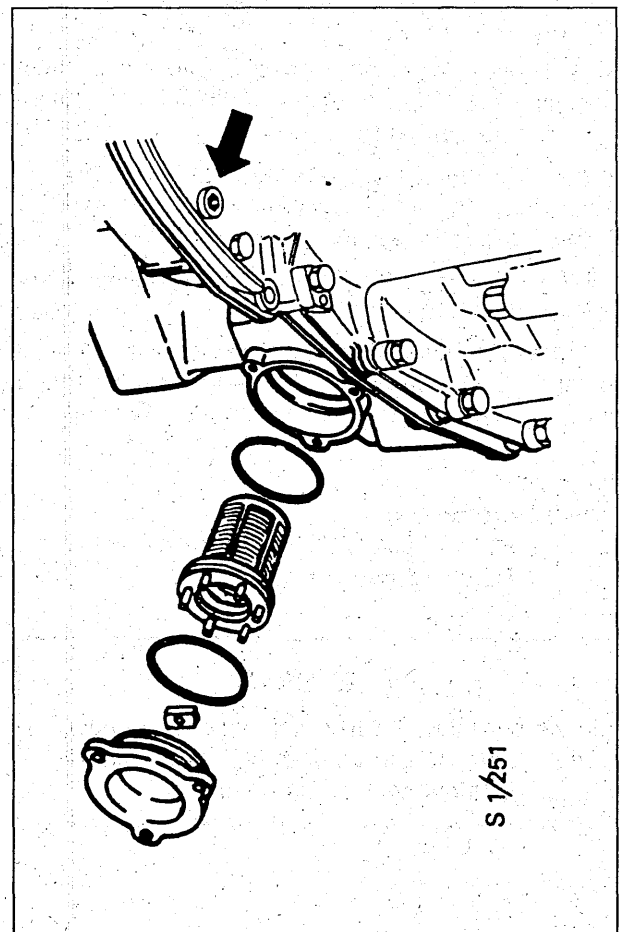

## Manual gearbox oil level

Remove the level plug. The oil should be level with the lower edge of the hole.

### Grade of fluid (not ME):

Motor oil (mineral oil) API-service SF/CC, SF/CD.

### Viscosity:

10W30 or 10W40.

### Grade of fluid (ME only):

SHPD B.P. Vanellus F.E.

### Viscosity:

10W30 or 15W40.

### Oil capacity:

When changing the oil: 1.8 litres.

---

### Important:

Synthetic motor oil must not be used.

---

**All plugs, tightening torque:**  
**50 Nm (37 lbf ft)**

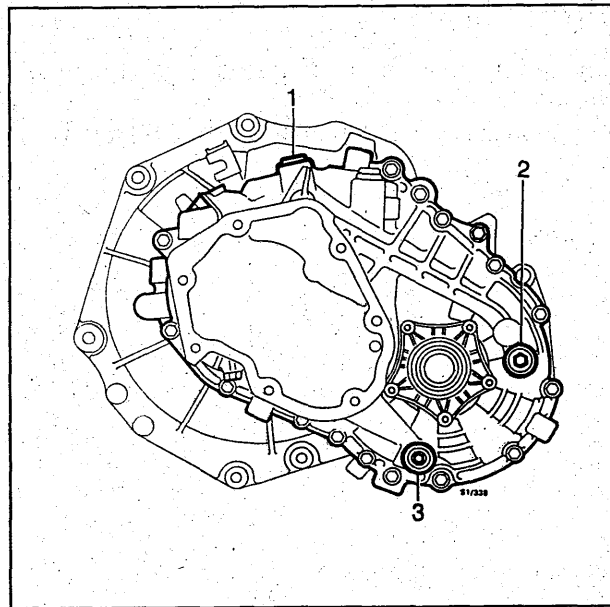

- 1 Filler plug
- 2 Level plug
- 3 Drain plug

## Fuel filter

Change the fuel filter and sealing rings at the hose unions.

The fuel filter is located adjacent to the fuel tank.

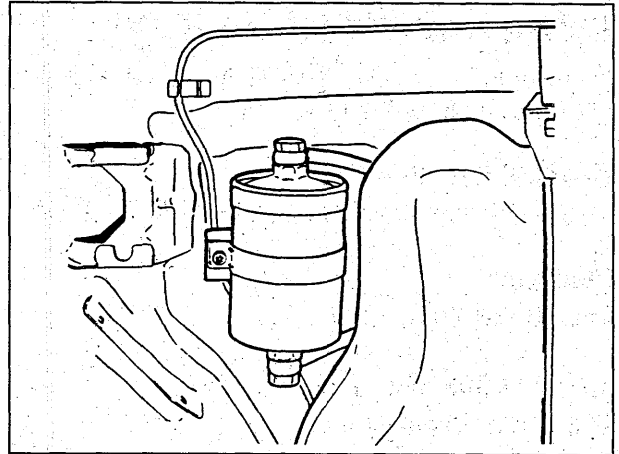

## Brake system

### Brake pads and brake discs

- Remove the wheels
- Check the thickness of the brake pads and the condition of the discs.
- It is advisable to change the pads when they have worn down to a thickness of 4 mm (0.16 in) or less.
- Tighten the wheel bolts to a torque of:
  - 117 Nm (86 lbf ft) - light alloy wheels
  - 100 Nm (74 lbf ft) - pressed steel wheels

---

### Important:

Retightening to the correct torque must only be done with a torque wrench.

When fitting **new light alloy wheels** for the first time, tighten the bolts to a torque of 125-145 Nm (92-107 lbf ft).

---

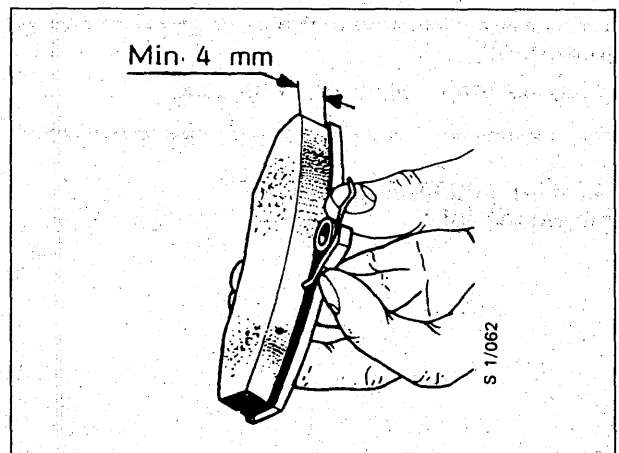

## Brake hoses and brake lines

Check for leakage, inspect mounting points and general condition.

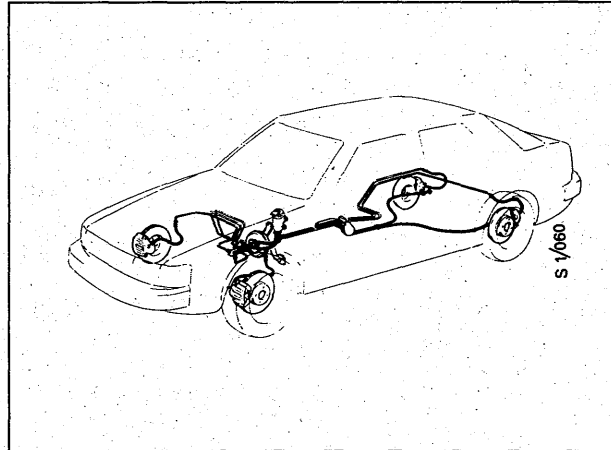

## Dampers and bushes

Check for leakage and inspect general condition.

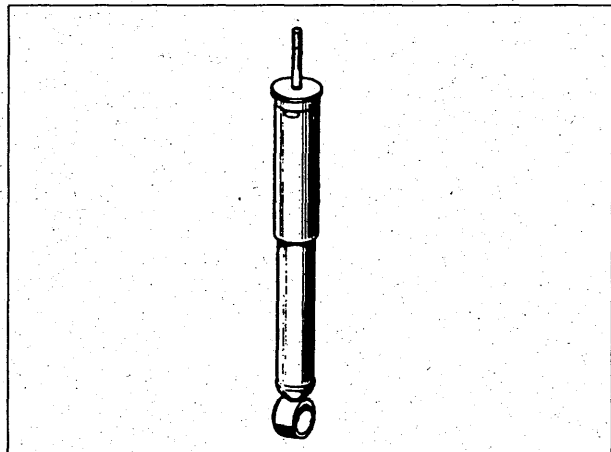

## Gaiters, inboard and outboard drive-shaft universal joints

Inspect the rubber gaiters round the drive-shaft universal joints for wear and integrity, and check that they are firmly secured.

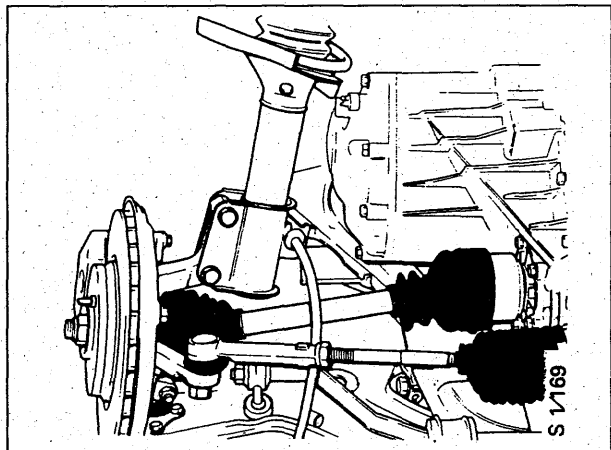

## Exhaust system

Check for leakage, inspect mounting points and general condition.

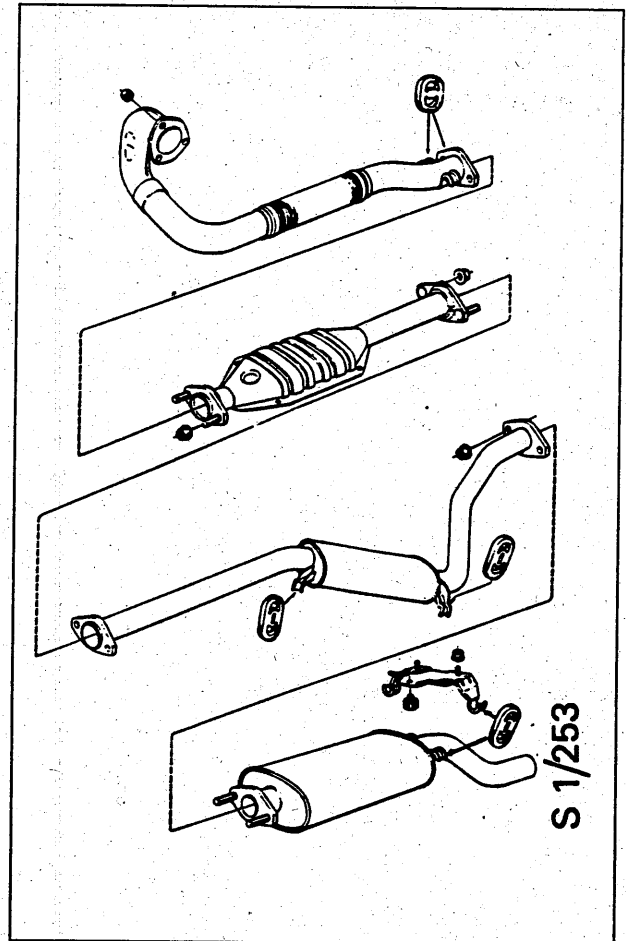

## Retightening

Tighten the indicated bolts to the prescribed torque.

### Front assembly

- a. Suspension arm ball joint to suspension arm  
30 Nm (22 lbf ft).
- b. Suspension arm front bearing to subframe  
50 Nm (37 lbf ft).
- c. Suspension arm rear bearing to subframe  
50 Nm (37 lbf ft).
- d. MacPherson strut to body  
47 Nm (35 lbf ft).

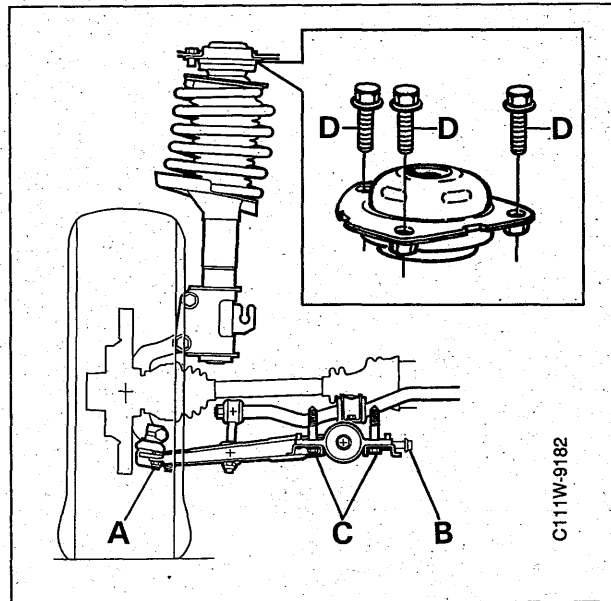

### Rear axle

- a. Spring link to body  
47 Nm (35 lbf ft).
- b. Torque arm to body  
24 Nm (18 lbf ft).
- c. Panhard rod mounting to body  
47 Nm (35 lbf ft).
- d. Crosspiece for Panhard rod mounting to body  
55 Nm (41 lbf ft).
- e. Anti-roll bar link to body (2)  
24 Nm (18 lbf ft).
- f. Support for Panhard rod mounting to body  
18 Nm (14 lbf ft).

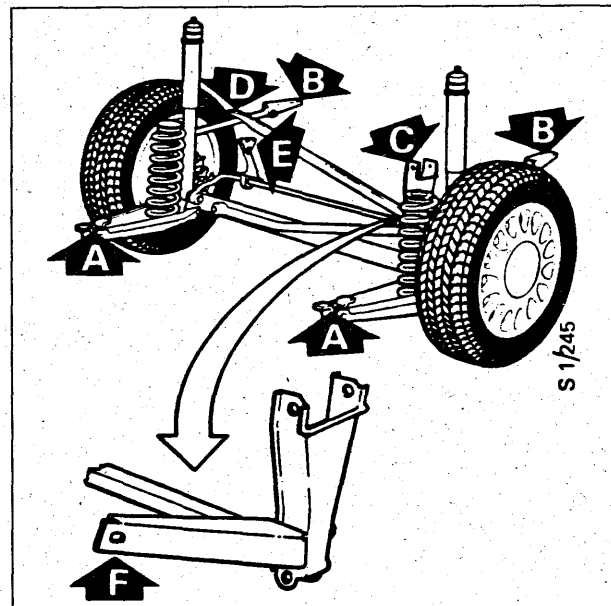

### Important:

Never overload the bolts in a joint by tightening them harder than to the specified torque.

### Steering ball joints and rubber gaiters

Check the inboard and outboard ball joints for wear.  
There should be no free play.  
Inspect the rubber gaiters.

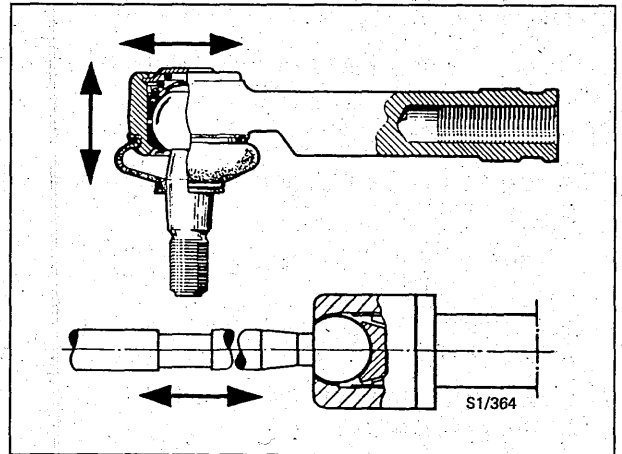

### Suspension ball joints and rubber gaiters

Inspect the ball studs for wear.  
There should be no free play.  
Inspect the rubber gaiters.

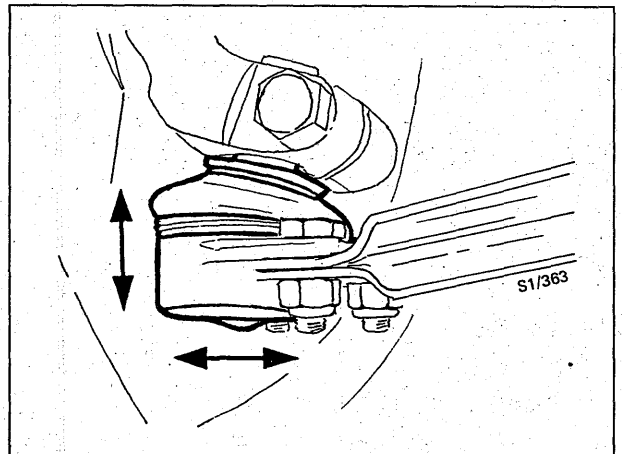

## Tyres

Measure the depth of tread and check the pattern of wear. Check the inflation pressures (including the spare wheel).

If the pattern of wear is uneven, check the toe-in and adjust as necessary.

The tyres incorporate wear indicators in the form of smooth, treadless stripes across the width of the tyre which become visible when only 1.6 mm of the tread remains. When this happens the tyres should be changed.

Make sure you are familiar with the national regulations on tread depth.

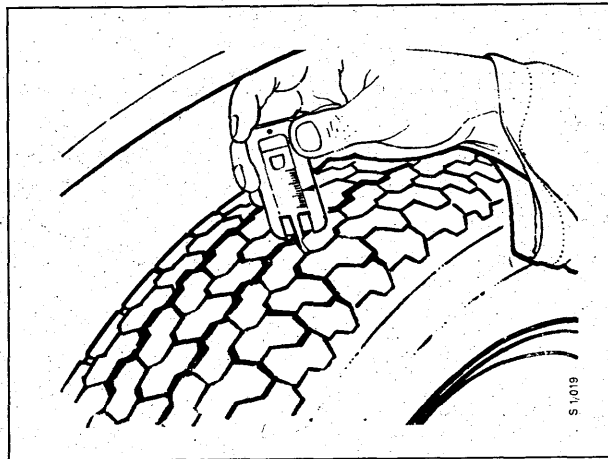

## Fuel system

Check the fuel lines and fuel tank for damage and leaks. Inspect the mounting points.

## Coolant, changing

Change the coolant (max. 3-year intervals).

Fill the system when the engine is cold but not above the MAX level mark. Warm up the engine until the thermostat opens and check the level of the coolant.

## Bleeding

- 1 Start the engine and run it at idling speed until the radiator fan starts (4-cyl) or has started three times (6-cyl).
- 2 If the car is equipped with a petrol-driven parking heater, bleed the system by removing the upper hose. If air is present in the system when the parking heater is started, it could be damaged. Start the heater and allow it to run for a while when the radiator fan has started.

## Coolant/cooling system

Check the anti-freeze mixture. The coolant should be able to withstand  $-30^{\circ}\text{C}$  to  $-35^{\circ}\text{C}$  ( $-22$  to  $-31^{\circ}\text{F}$ ) without freezing. Top up as necessary with equal amounts of SAAB Original Coolant and water (half and half).

**Important:** This mixture also provides effective corrosion protection.

Avoid mixing different types of coolant.

Fill the system when the engine is cold but not above the MAX level mark. Warm up the engine until the thermostat opens and check the level of the coolant.

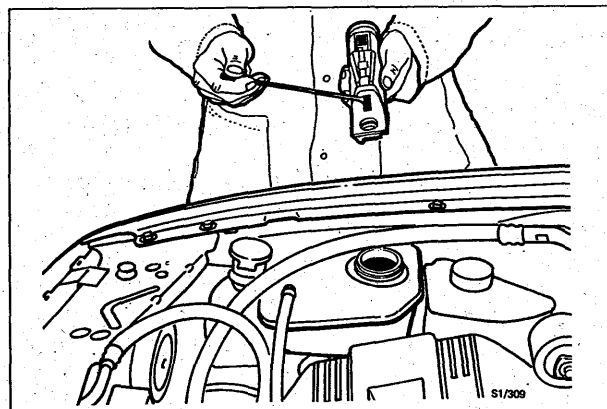



Check the condition of the hoses.

---

**Important:**

Screw the filler cap down hard or the system will not be pressurized, resulting in a lower boiling point and loss of coolant.

---

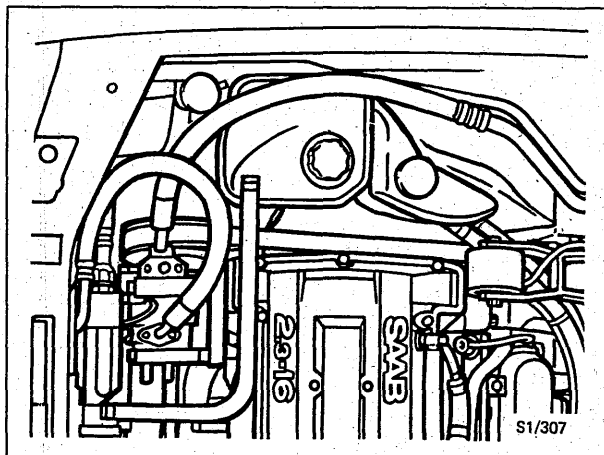

### Fluid level, brakes and clutch

Check the level and top up as necessary.

**Brake fluid:**

Grade: to DOT 4 specification.

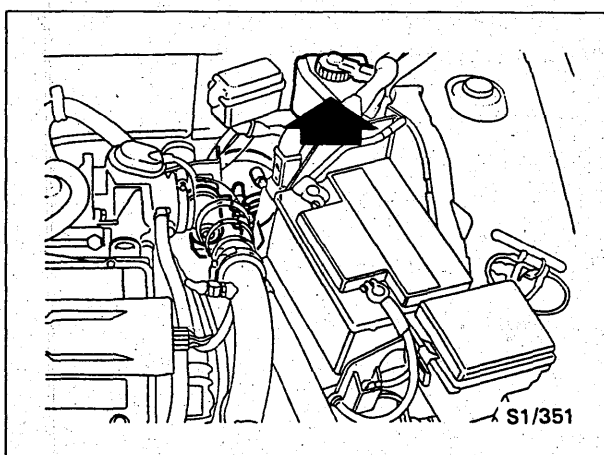

## Brake/clutch fluid

Change, or at least every other year.

Grade: to DOT 4 specification.

Never use brake fluid which has been stored in an open container.

---

### Important:

See Service Manual 5:2, in which special safety procedures are described.

---

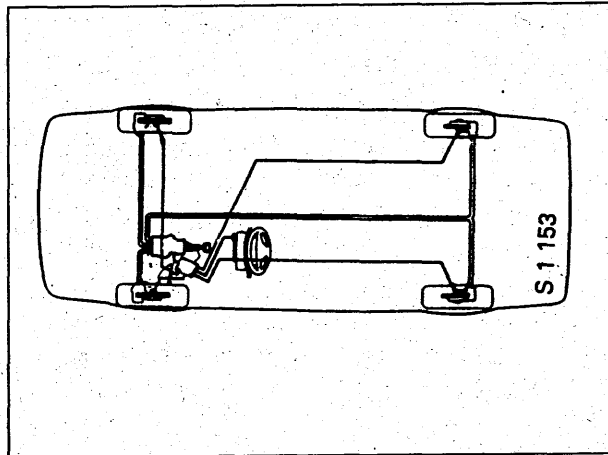

ABS brake system

Fill in the "BRAKE FLUID changed" label and affix it somewhere suitable on the front assembly near the brake fluid reservoir.

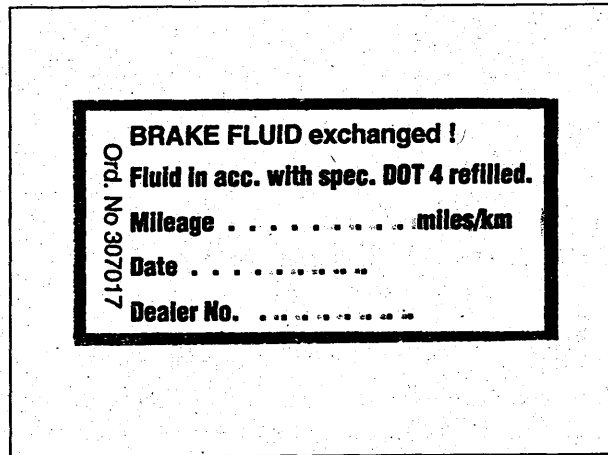

## Fluid level, automatic transmission

Start the engine and run it at idling speed. Engage D and wait at least 15 seconds. Then engage R and wait another 15 seconds. Repeat in position P.

Check the fluid level (engine running at idling speed and selector lever in P). Top up as necessary.

Pay attention to the appearance of the fluid and its odour. If it is turbid or discoloured and/or smells burnt, a change is advisable even if no complaints have been made about poorer shifting performance or excessive noise.

### Important:

The dipstick has two sets of level marks. The amount of fluid between the maximum and minimum marks is about 0.4 litres (0.4 qts).

### Grade of fluid (not ME):

DEXRON II automatic transmission fluid.

### Grade of fluid (ME only):

DEXRON IIE automatic transmission fluid.

## Fluid level, power steering

Check the level and top up as necessary. If the fluid level is low, investigate the cause.

### Grade of oil:

Saab Power Steering Fluid 4634, part No. (45) 30 09 800 - 0.75 litres.

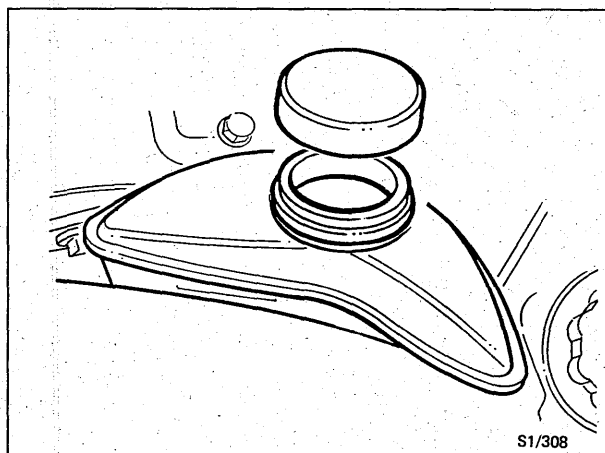
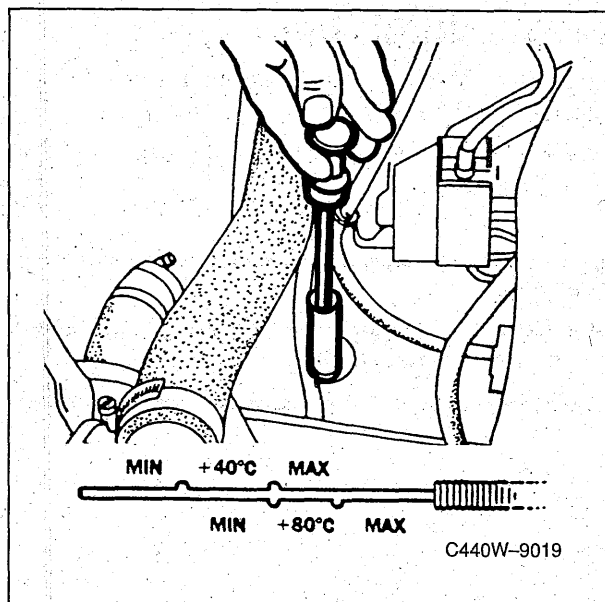

## Throttle body (not B308)

Disconnect the throttle body's induction hose, open the throttle butterfly and use a cloth moistened with solvent to clean and wipe dry the inside of the throttle body.

Do this if the engine idles roughly or not at all.

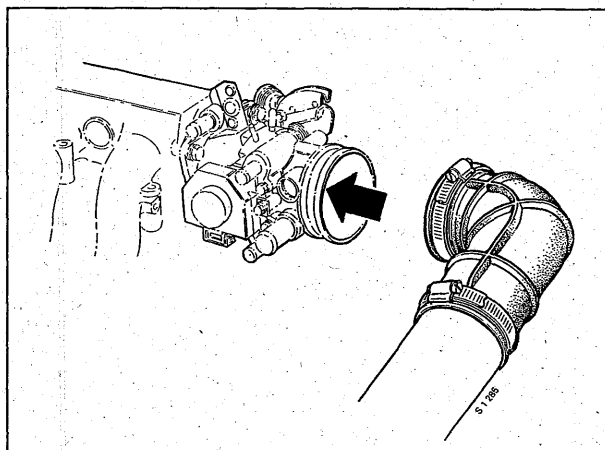

## Spark plugs

Engine*	Designation
2.0 l fuel injection	NGK BCPR 6ES
2.0 l Turbo	NGK BCPR 7ES
2.3 l fuel injection	NGK BCPR 6ES
2.3 l Turbo	NGK BCPR 7ES
V6 fuel injection	Bosch FR 8 LDC (Normal driving) Bosch FR 7 LDC (Hard driving)

### Electrode gap:

Spark plugs (type 2 in the Fig.) should be checked with a wire gauge.

Engine management system	Engine	Electrode gap. mm (in)
Trionic	2.0 l, 2.3 l	1.0 - 1.1 (0.039 - 0.043)
Motronic	V6	0.7 - 0.9 (0.027 - 0.035)

### Tightening torque:

27 Nm (20 lbf ft)

### Important:

Use tool 83 94 785 to avoid all danger of breaking the V6 engine's spark plugs.

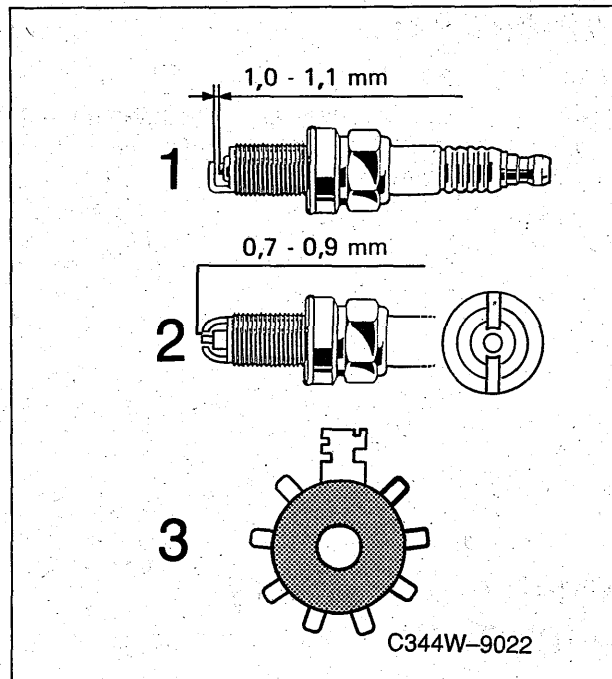

- 1 With Trionic
- 2 With Motronic, V6
- 3 Wire gauge

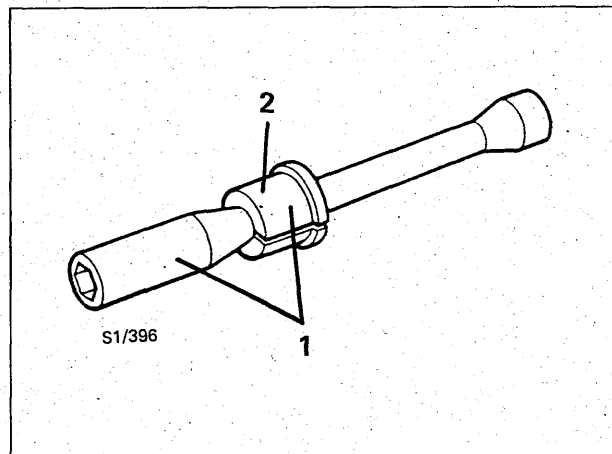

- 1 Tool 83 94 785 - complete
- 2 Sleeve 83 94 843

## Air cleaner

Change the filter element.

If the car is used in an extremely polluted environment, it is advisable to change the filter element at more frequent intervals.

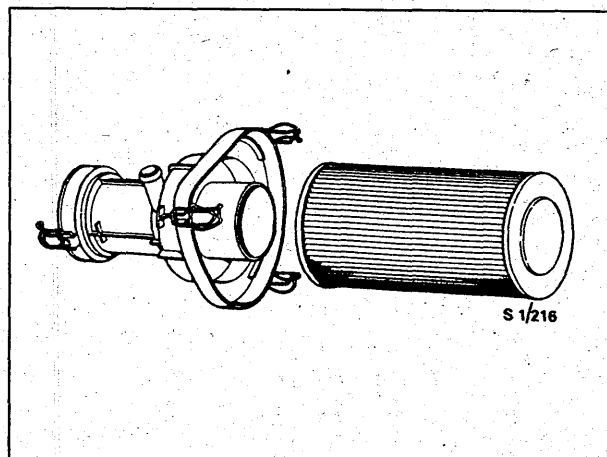

## Driving of auxiliary equipment

Check the operation and condition of the belt tensioner by pressing on it. The belt should return smoothly and evenly to its correctly tensioned state.

Test value for the drive belt: at least 170 N (40 lbf).

Check the condition of the drive belt. It should be replaced when loss of material (note: not just cracks) larger than 5 mm in the longitudinal direction of the V-belt has occurred or if other damage has arisen.

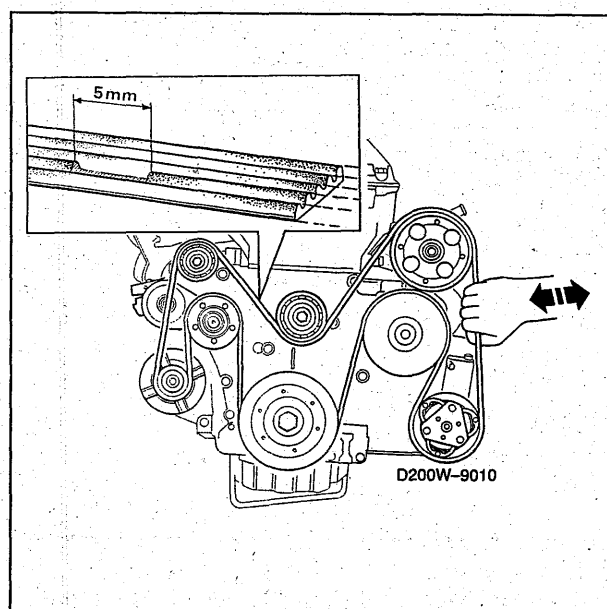

### Camshaft transmission, B308

For replacement, see Service Manual 2:1 "Basic engine B308".

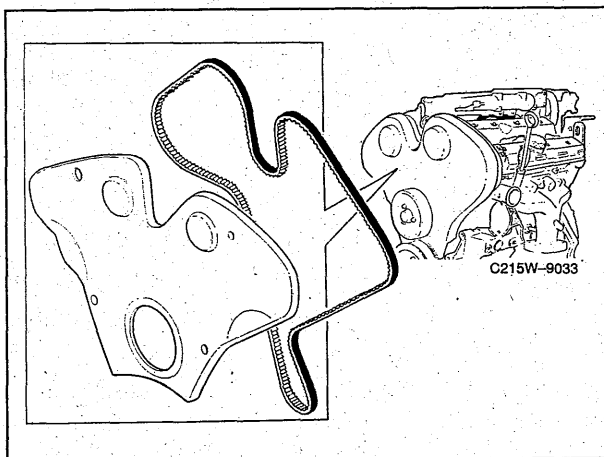

Fill in the "TIMING BELT REPLACED" label and affix it to the front part of the timing cover on the outside.

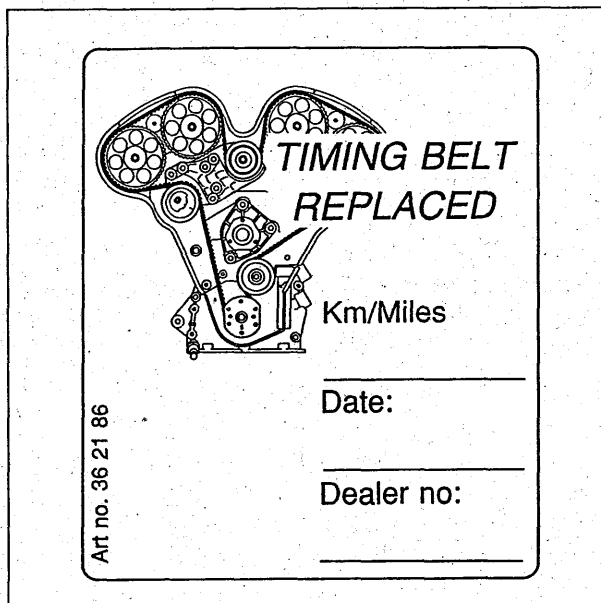

## Battery

Clean and inspect the battery terminals and retaining bracket. Smear the terminals with petroleum jelly (Vaseline). It is important to ensure that the battery is firmly and safely secured.

Connect a spare battery if the battery cables have to be disconnected in order to clean the terminals.

Check the level of the electrolyte. If the electrolyte level in any cell is extremely low, it is advisable to check the voltage.

Disconnect the positive cable from the battery. Take a voltage reading. If the voltage is below 12.4 V the battery needs charging (fully charged = 12.72 V).

If the voltage is below 12.0 V the battery will have to be changed.

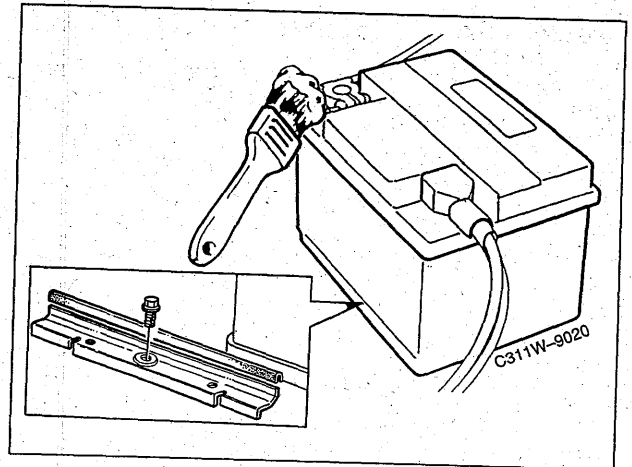

Inspect the battery's positive and negative (ground) cables and their connections for possible damage.

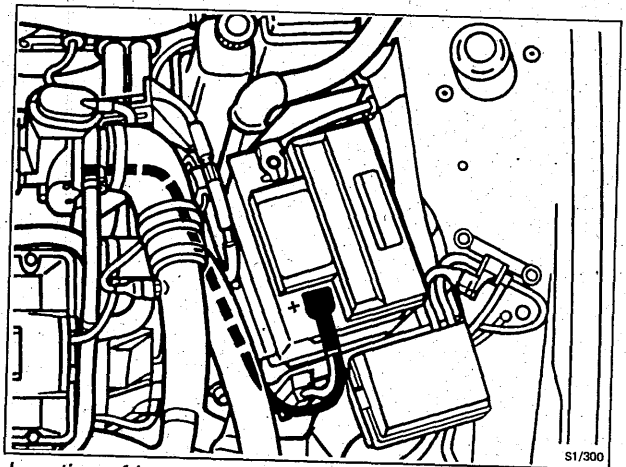

Location of battery, M1994

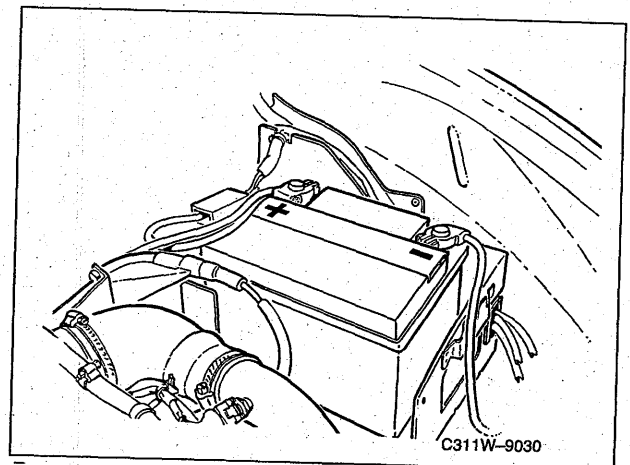

Location of battery, M1995-

## Washer fluid

Check the level of the fluid in the reservoir and top up as necessary with a mixture of washer fluid and water (according to the table of recommendations on the packaging).

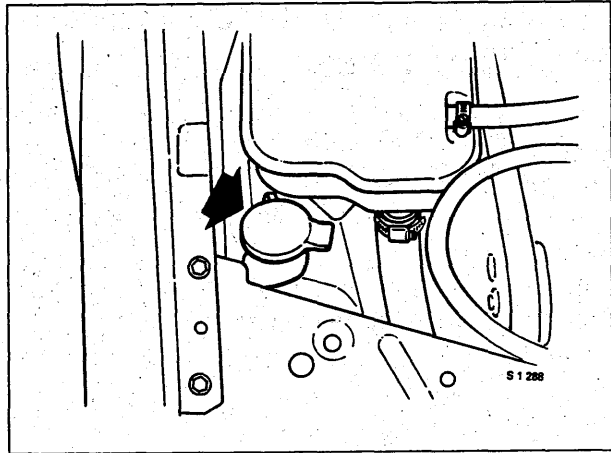

## Washer nozzles

Clean and adjust the washer nozzles as necessary.

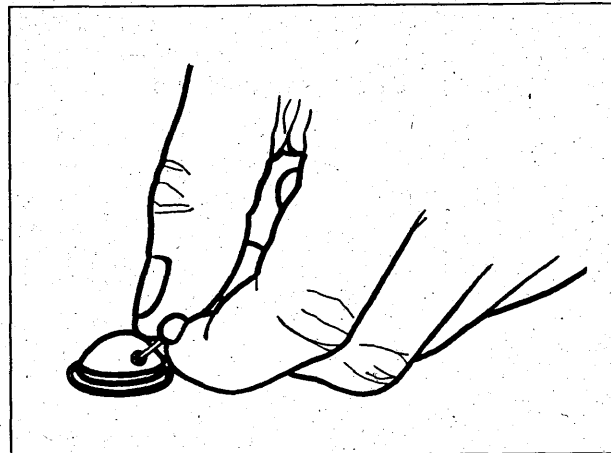

## Wiper blades

Inspect the condition of all wiper blades.

- 1 Lubricate the hinges, etc. with Gleitmo 582 (white grease) or Gleitmo 540.
- 2 Inspect the condition of all wiper blades.



## Ventilation air filter

Change the filter element.

When driving in exceptionally dusty or polluted environmental conditions, or in the case of susceptibility to allergic disorders, changing the filter element at more frequent intervals is recommended.

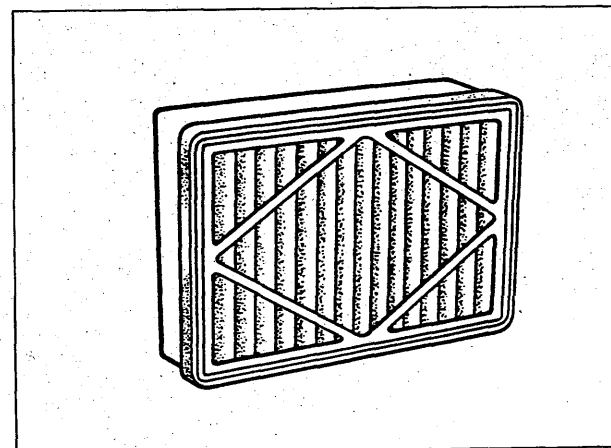



## Doors, bonnet, tailgate, etc. and door keeps

Check the operation of all locks for the doors, the child safety catches for the rear doors, the tailgate and fuel filler flap.

Also check the operation of the bonnet lock and its safety catch.

The central locking system is operated from both front doors and also from a switch on the centre console.

Open the boot lid/tailgate on 9000 CD and CS models from outside by means of the car key and the switch on the inside of the driver's door.

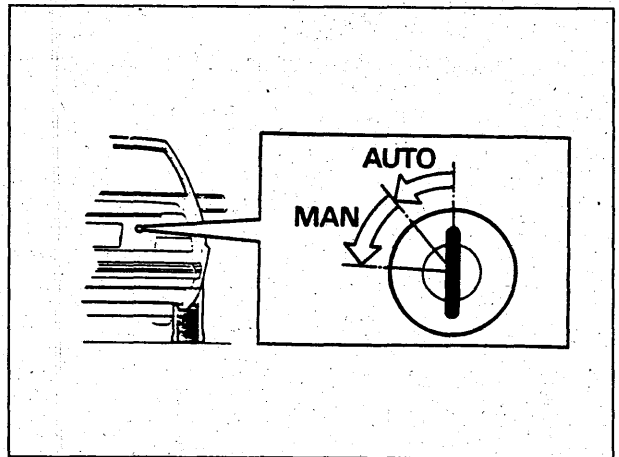
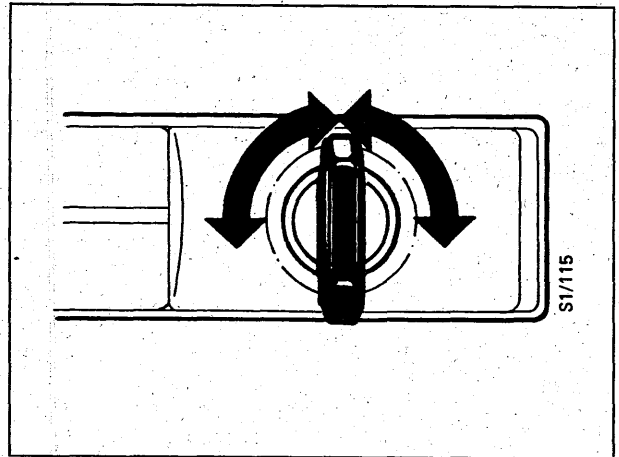

## Lubrication

Lubricate the door keep arms with Gleitmo 800 (45) 30 06 582.

Lubricate the bonnet locks and locking pins with Gleitmo 805 (45) 30 06 442.

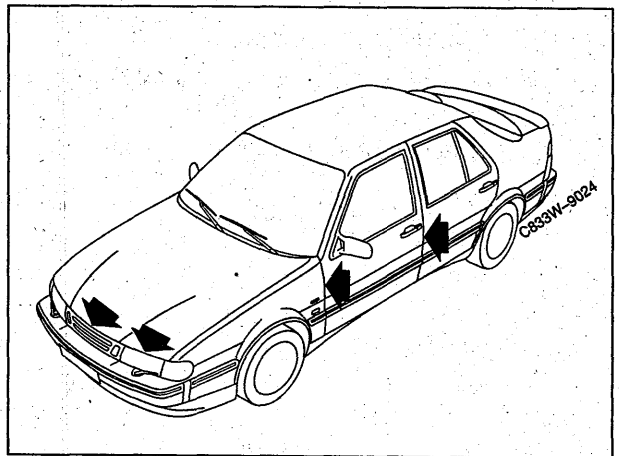

## Seat belts

Check the operation of the seat belts and inspect the straps for damage.

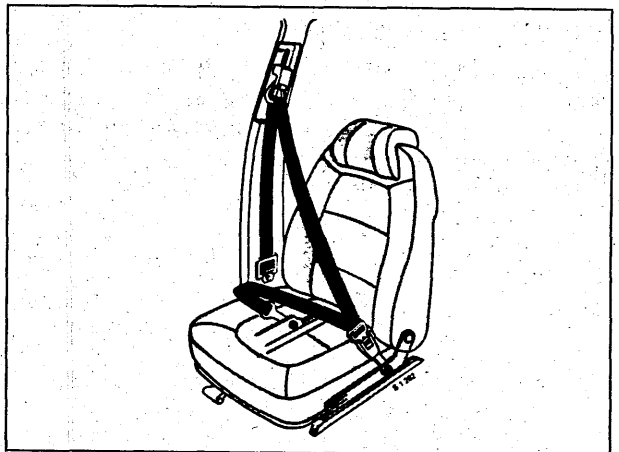

## Toe-in

Note the following when checking and/or adjusting toe-in with special tool No. 88 19 013:

- Check and adjust tyre inflation pressures.
- Toe-in  $1.5 \pm 0.5$  mm ( $0.06 \pm 0.02$  in).

**Tightening torque: track-rod end locknuts 60-80 Nm (44-59 lbf ft).**

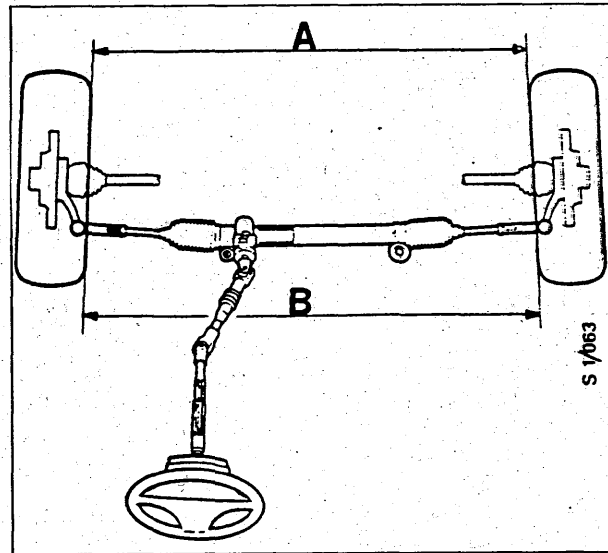
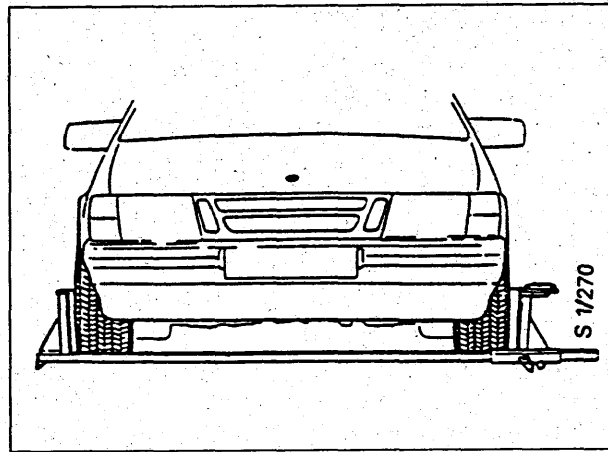

**Important:**

When toe-in has been adjusted, dimension C between the locknut and the edge of the groove in the track rod must never exceed 140 mm (5.5 in).

The difference in dimension C on each side of the car must not exceed 2 mm (0.08 in).

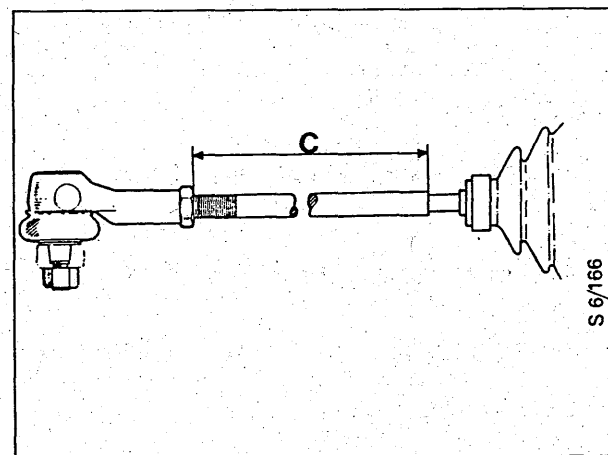

## Airbag system

Turn the ignition switch to the Drive position and check that the SRS warning lamp lights up for six seconds and then goes out. In the event of a fault indication, read the diagnostic trouble code and remedy the fault. See Service Manual 8:6 "Airbag".

Inspect the steering wheel centre pad (airbag module) and passenger airbag module, if fitted, for external damage, making sure that the surfaces are free from scratches and pinpricks.

Make sure that nothing has been fitted that could be flung through the air or damage the airbag in the event of airbag detonation. Pay particular attention to the area for the passenger airbag.

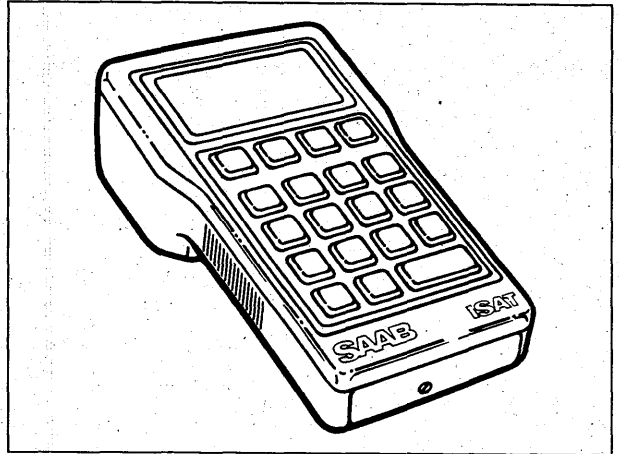

## Road test

The road test is an important part of the service programme. Check the various functions as described below.

- Ignition switch  
Check that the steering-column lock operates satisfactorily and that the key is easy to insert and remove.
- Check the Parking position lock on cars with automatic transmission (certain markets only)
- Engine  
Operation and noise level. Turbo: check that boost pressure is normal during acceleration (needle moves up to the red zone).
- Clutch  
Check the positions of the pedal at which the clutch disengages and begins to engage.
- Manual gearbox  
Check gearbox operation and noise level.
- Automatic transmission  
Check the selector lever detent, noise level and shifting performance.
- Wheels  
Check wheel balance and wheel roundness.
- Steering  
Check the straight-ahead position of the steering wheel, directional stability and operation of the power steering system.
- Instruments and indicator lamps  
Check the operation of instruments and indicator lamps.
- Brakes  
Check brake pedal travel, handbrake lever travel (4-5 notches), and the efficiency of the brakes and handbrake.
- Cruise Control  
Check the operation of the Cruise Control system.

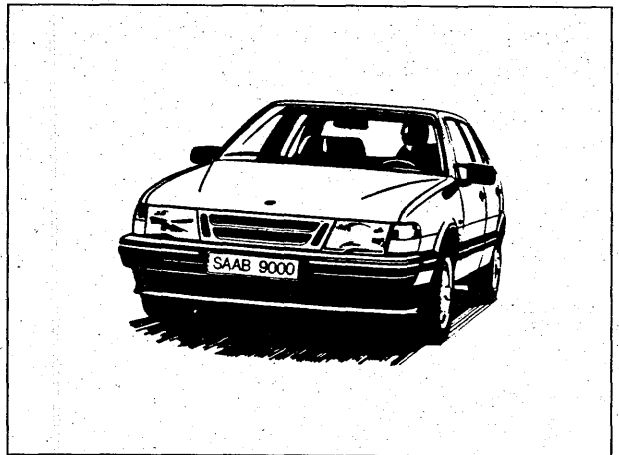

- Climate control system  
Check the operation of the A/C system and the heating and ventilation system, and their controls. When the outdoor temperature is so low that the A/C system cannot be turned on, check the operation of the system indoors.
- Wipers and washers  
Check the washer jet pattern and wiper operation on the windscreen and, if relevant, the rear window.
- Check that the clock shows the right time.

**Bear in mind what the customer might think!**  
Wipe the steering wheel and gear lever clean and make sure that all other traces of pre-delivery inspection and service work have been removed.

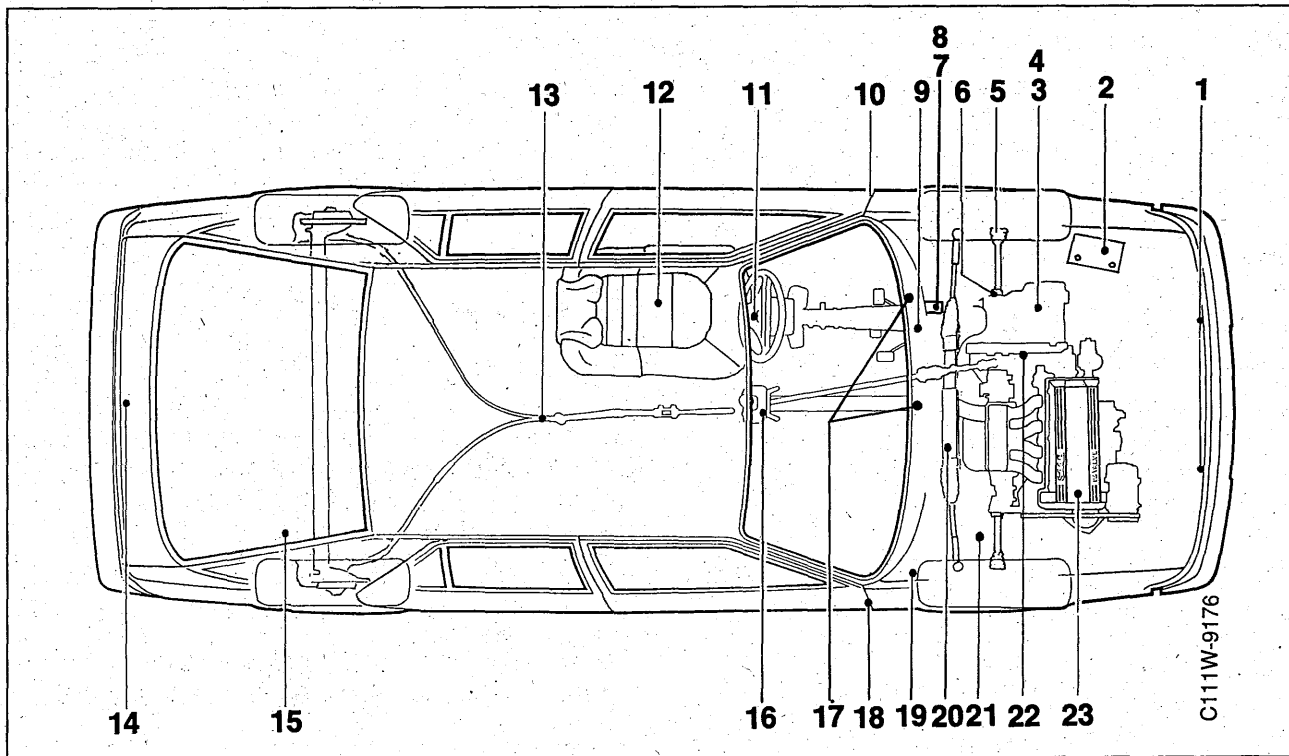

## Lubrication, lubricants

### Lubrication in conjunction with service work

Item	Lubrication point	Lubricant
1	Locking pins, safety latch and bonnet lock	Gleitmo 805 (45) 30 06 442
2	Battery	Petroleum jelly (Vaseline), part No. (45) 30 06 665
3	Manual gearbox	Not ME: Motor oil (mineral oil) to API service SF/CC, SF/CD. Viscosity: 10W30 or 10W40 ME only: SHPD B.P. Vanellus F.E. Viscosity: 10W30 or 15W40 <b>Synthetic motor oil must not be used.</b>
4	Automatic transmission	Not ME: ATF DEXRON II ME only: ATF DEXRON IIE
5	Outboard drive-shaft universal joint	Molycote VN 2461C part No. (45) 87 81 676
6	Inboard drive-shaft universal joint	Mobile Grease K 575GS
7	Brake system	Brake fluid grade: to DOT 4 specification
8	Hydraulic clutch mechanism	Brake fluid grade: to DOT 4 specification
9	Brake light switch	Petroleum jelly (Vaseline), part No. (45) 30 06 665
10	Door switch, interior lighting	Petroleum jelly (Vaseline), part No. (45) 30 06 665
11	Horn slip-ring and brushes	Gleitmo 165
12	Seat rails	Saab special chassis grease EP 2, part No. (45) 30 09 990 (sparingly)
13	Handbrake cables	Saab special chassis grease EP 2, part No. (45) 30 09 990
14	Tailgate lock mechanism	Thin penetrating oil

Item	Lubrication point	Lubricant
15	Rear anti-roll bar bushes	Molycote 33 medium, part No. (45) 30 20 476
16	Gear lever housing	Gleitmo 980 spray, part No. (45) 30 06 954. Leave to dry for 15 minutes and then smear with Gleitmo 750 grease, part No. (45) 30 07 309 paste
17	Windscreen wiper arm	Gleitmo 582 (white grease) or Gleitmo 540
18	Door keeps	Gleitmo 880 (45) 30 06 582
19	Bonnet hinges	Vaseline, part No. (45) 30 06 665, or Gleitmo 805 (45) 30 06 442
20	Power steering	M1994: Saab Power Steering Fluid 1890, part No. (45) 30 02 995 - 0.75 litres or Saab Power Steering Fluid 4634, part No. (45) 30 09 800 - 0.75 litres M1995, 1996: Saab Power Steering Fluid 1890, part No. (45) 30 02 995 - 0.75 litres
21	Front anti-roll bar bushes	Molycote 33 medium (45) 30 20 476
22	Input shaft splines	Molycote Rapid G, part No. (10) 87 81 684, or Molybdenum sulphide paste, Gleitmo (45) 30 06 632
23	Engine	Grade of motor oil: Saab Turbo motor oil or motor oil to API SG and CCMC G4/G5 specifications. These oils contain suitable additives for the engine. We advise against the use of additional additives. Viscosity: SAE 10W-30, 10W-40, 5W-30 or 5W-40. If these grades are unobtainable, 15W-40 oil may be used but not during the winter. If 5W oils are used, they must be of fully-synthetic or semi-synthetic type. In countries where the temperature never falls below +15-20°C, oil having a viscosity of 15W-50 or 20W-50 is recommended.

### Lubrication to prevent seizing

Threaded joints subjected to wide temperature fluctuations may tend to seize and will then be difficult to unscrew on the next service occasion.

Typical threaded joints of this type are:

- EGR valve connections
- Oxygen (Lambda) sensor
- Retaining nuts for the exhaust manifold and turbocharger

Recommended lubricants: MOLYCOTE 1000 (45) 30 20 971 or NEVER SEIZE.





**SAAB**

Saab Automobile AB  
Trollhättan, Sweden



Ordering No. 362095. English edition. Printed in Sweden. © Saab Automobile AB, 1995.

