

Saab 9000

Service Manual

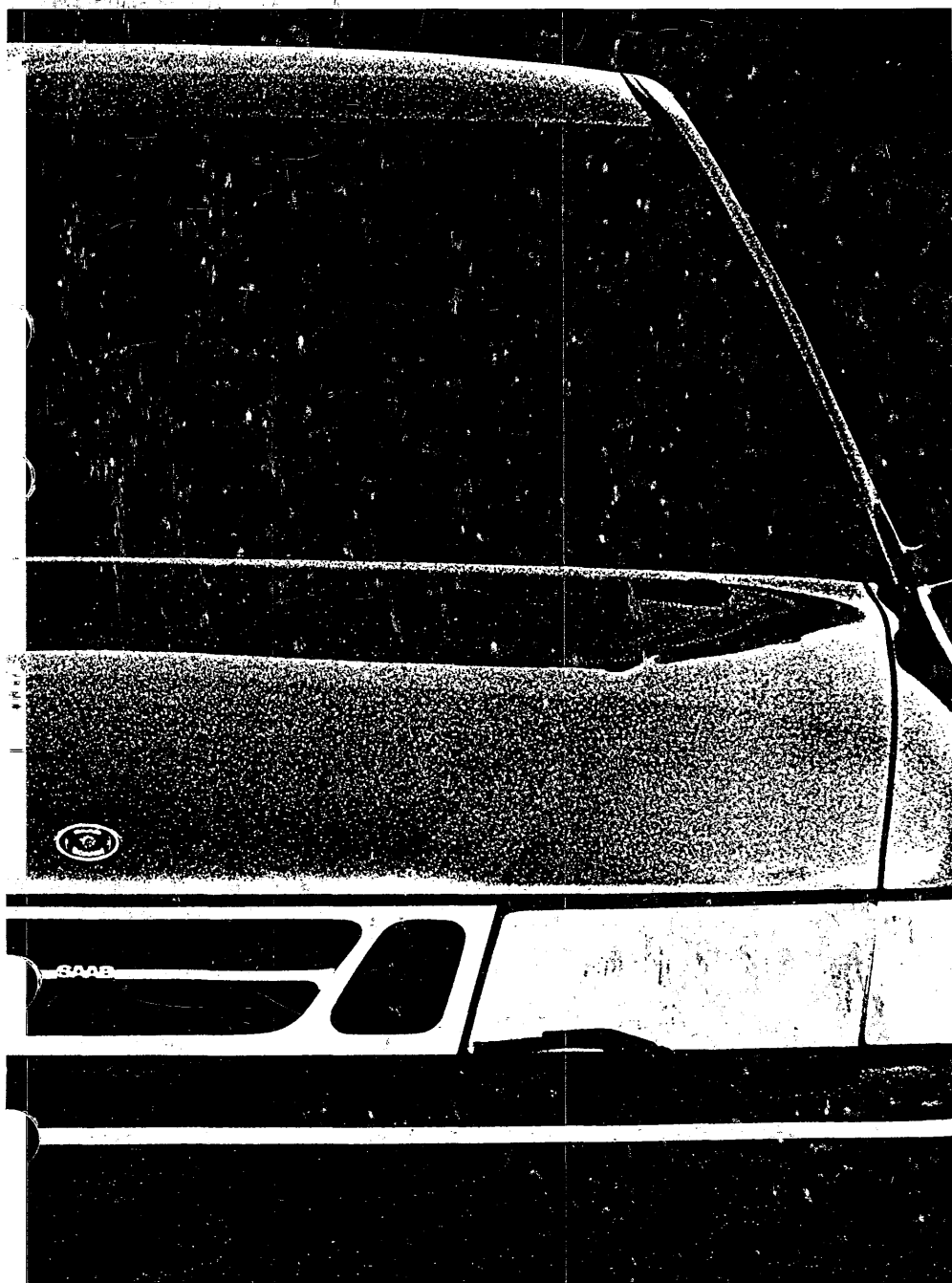

M 1995

ENG

2:5 Traction Control System B308

Saab 9000

SERVICE MANUAL

2:5 Traction Control System B308 M 1995

Preface

All information and illustrations in this Service Manual are based on the design of the cars at the time of the final editing of the manuals. Choice of models, technical data and equipment vary from one market to another and may be changed without prior notice.

Saab Automobile AB

Technical data	1
Special tools	3
Technical description	5
Fault diagnosis	27
Adjusting/changing components	57
Connectors and grounding points	63
Wiring diagram	67



RECYCABLE PAPER

Warning, Important and Note

The headings "Warning", "Important" and "Note" occur from time to time in the Service Manual. They are used to draw the attention of the reader to information of special interest and seriousness. The importance of the information is indicated by the three different headings and the difference between them is explained below.

WARNING

Warns of the risk of material damage and grave injury to mechanics and the driver, as well as serious damage to the car.

Important

Points out the risk of minor damage to the car and also warns the mechanic of difficulties and time-wasting mistakes.

Note

Hints and tips on how the work can be done in a way that saves time and labour. This information is not supplied for reasons of safety.

Market codes

The codes refer to market specifications

AT	Austria	GB	Great Britain
AU	Australia	GR	Greece
BE	Belgium	IS	Iceland
CA	Canada	IT	Italy
CH	Switzerland	JP	Japan
DE	Germany	ME	Middle East
DK	Denmark	NL	Netherlands
ES	Spain	NO	Norway
EU	Europe	SE	Sweden
FE	Far East	US	USA
FI	Finland	UC	US California
FR	France		

Technical data

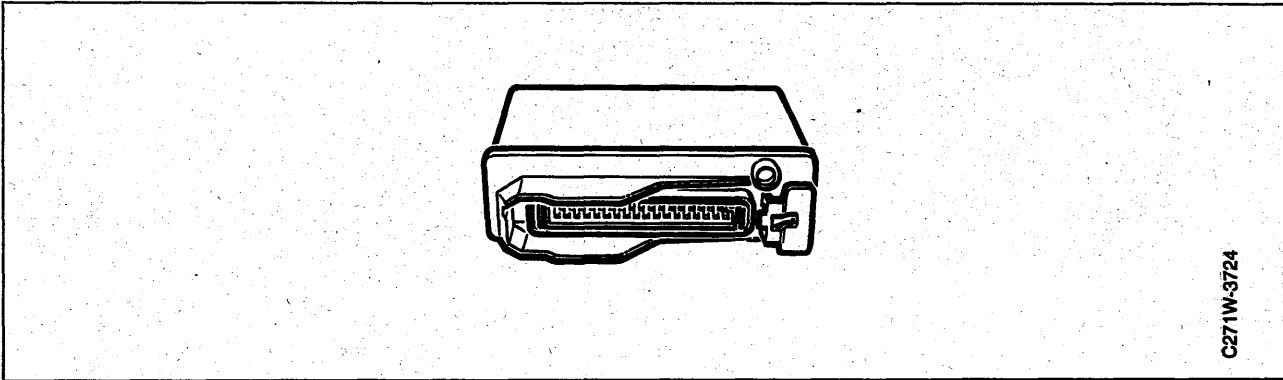

TCS control module

Number of terminal pins	quantity	35
Voltage supply +30	pin No.	32
Voltage supply +15	pin No.	28
Main ground	pin No.	13 and 30

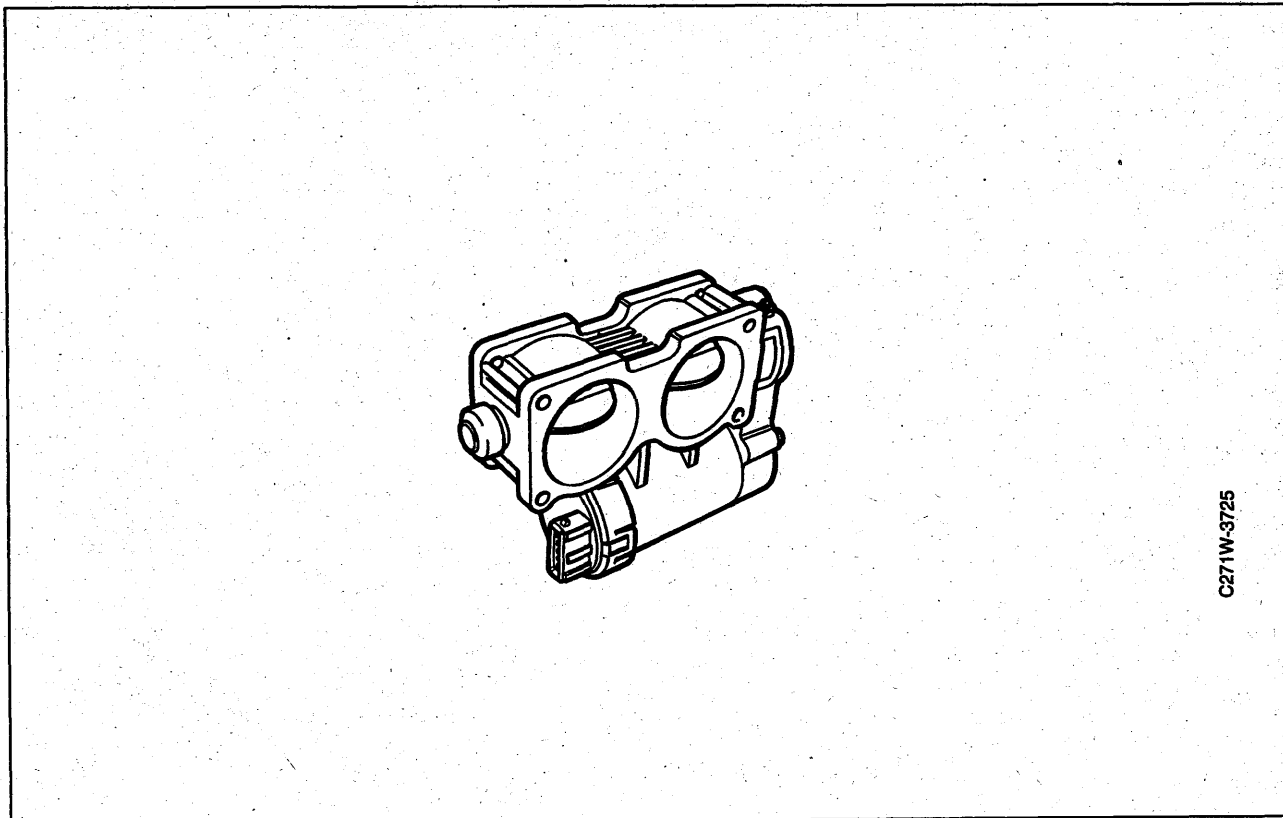

Throttle body TCS

Engine

Engine, feed (PWM)	Hz	500 (0-100%)
Engine, resistance, pins 1-5	Ohm	1,2

Position sensor

Position sensor, resistance, pins 2-4	Ohm	1100 ±100Ω
---------------------------------------	-----	------------

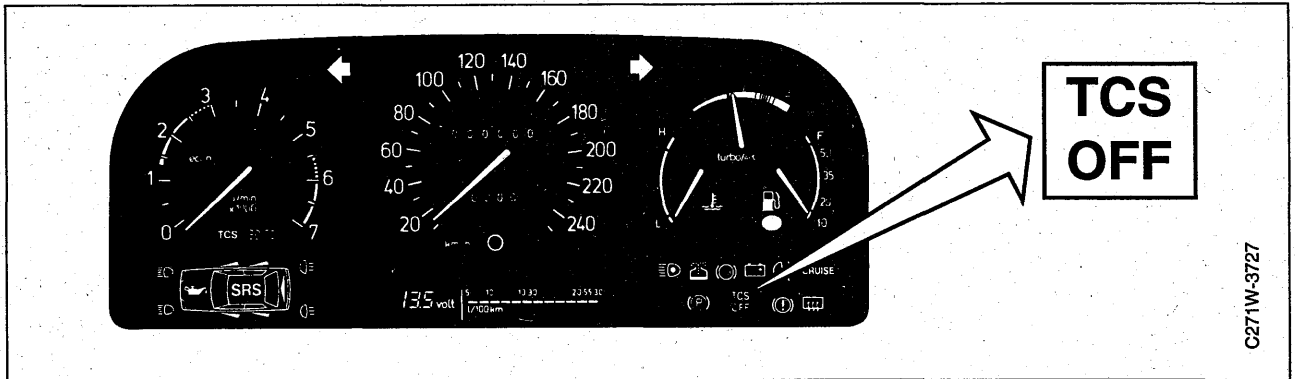

C271W-3727

TCS warning lamp

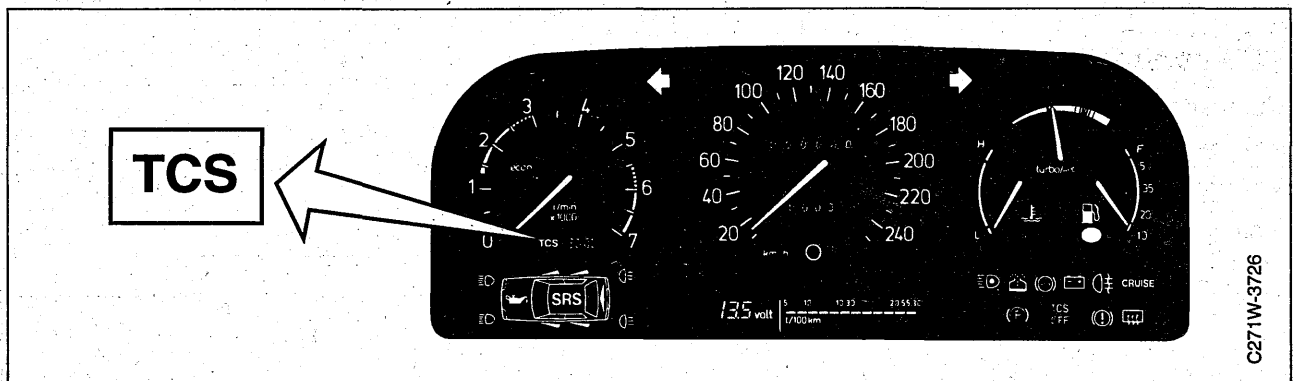

C271W-3726

TCS function lamp

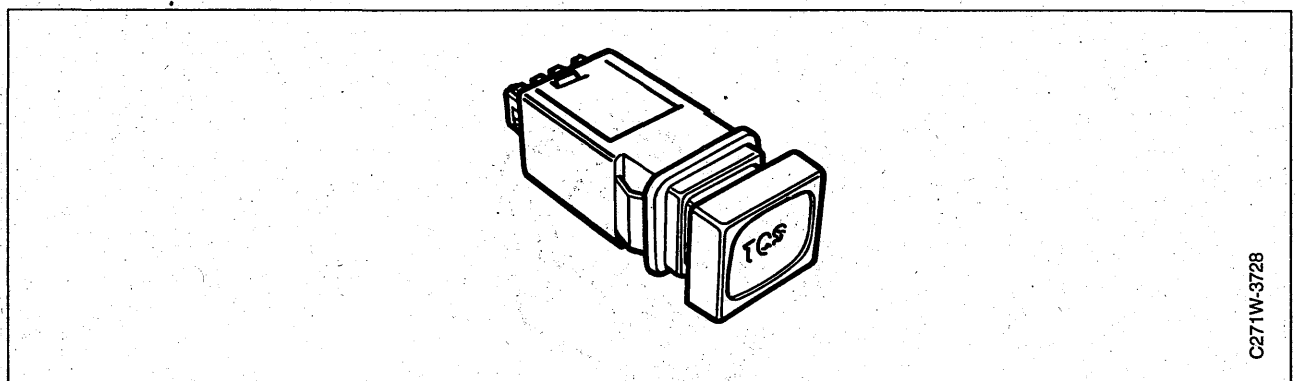

C271W-3728

TCS switch ON/OFF

Special tools

86 11 158 Test lead for Breakout-box

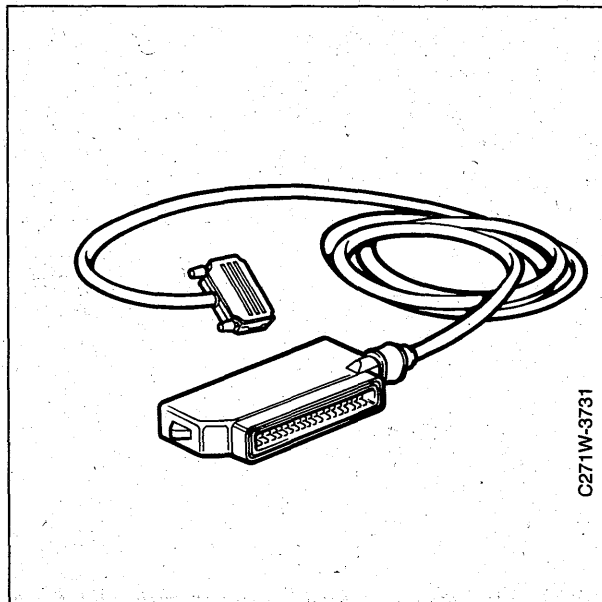

86 11 345 Bridging lead

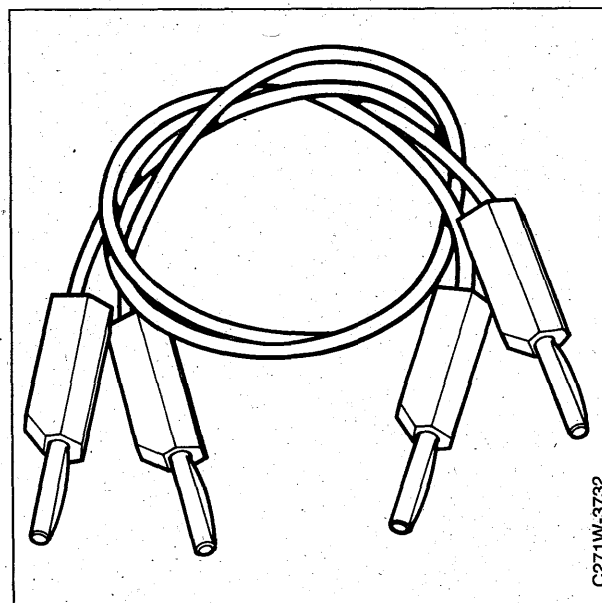

86 11 352 Test leads for pin connection (male pins)

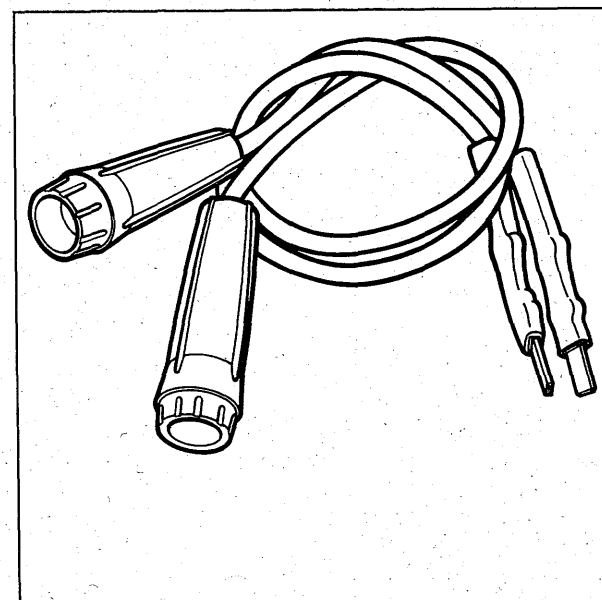

4 Special tools

86 11 410 Test leads for pin connection (female pins)

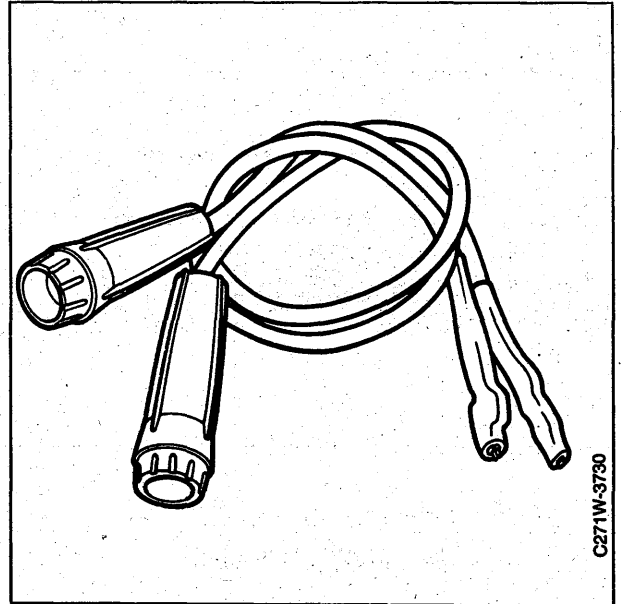

87 92 459 Regulator wire for accelerator/kickdown

Technical description

Description of TCS 6

Operation descriptions 12

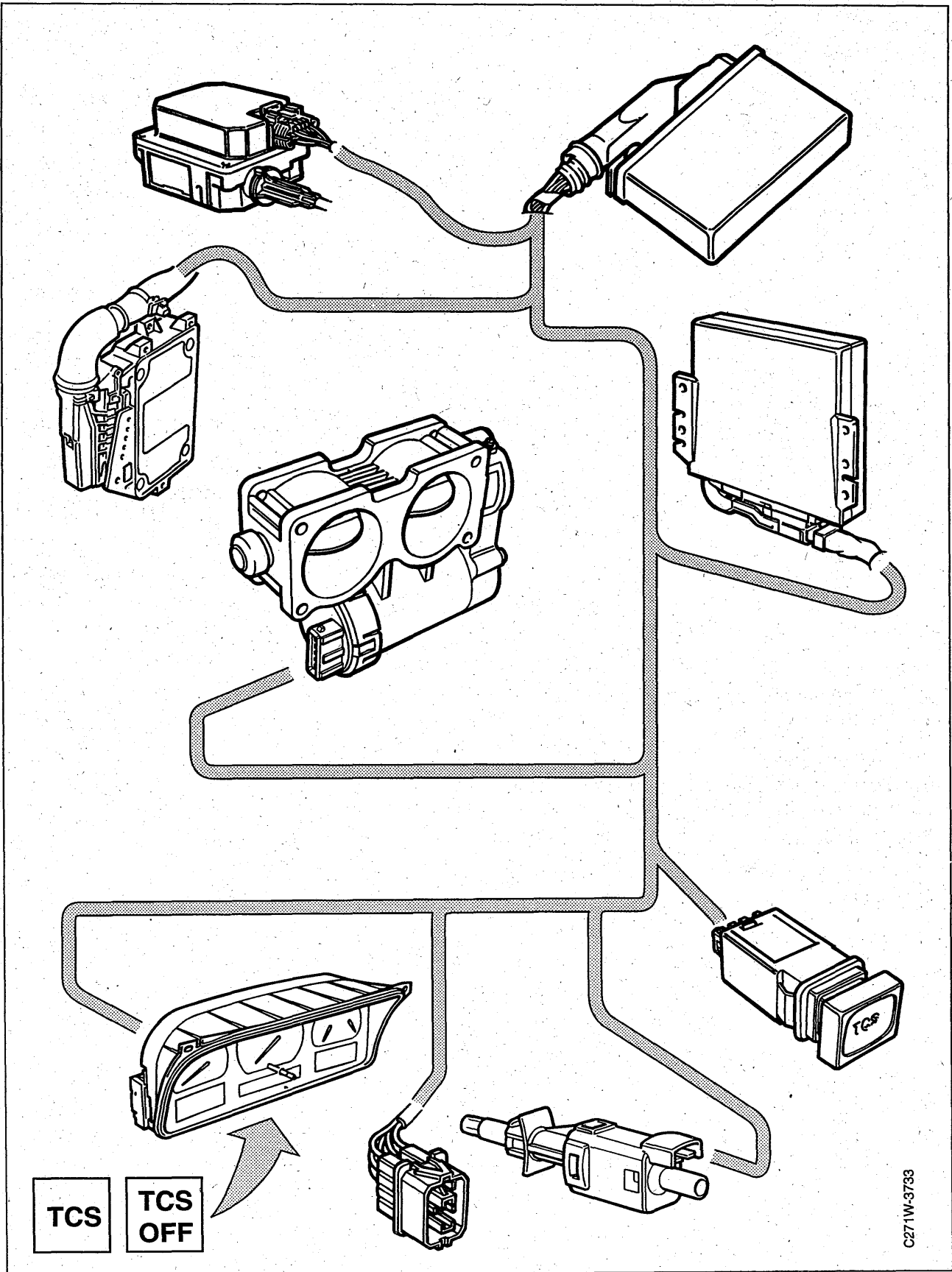

C271W-3733

Twin Throttle System

Description of TCS for B308

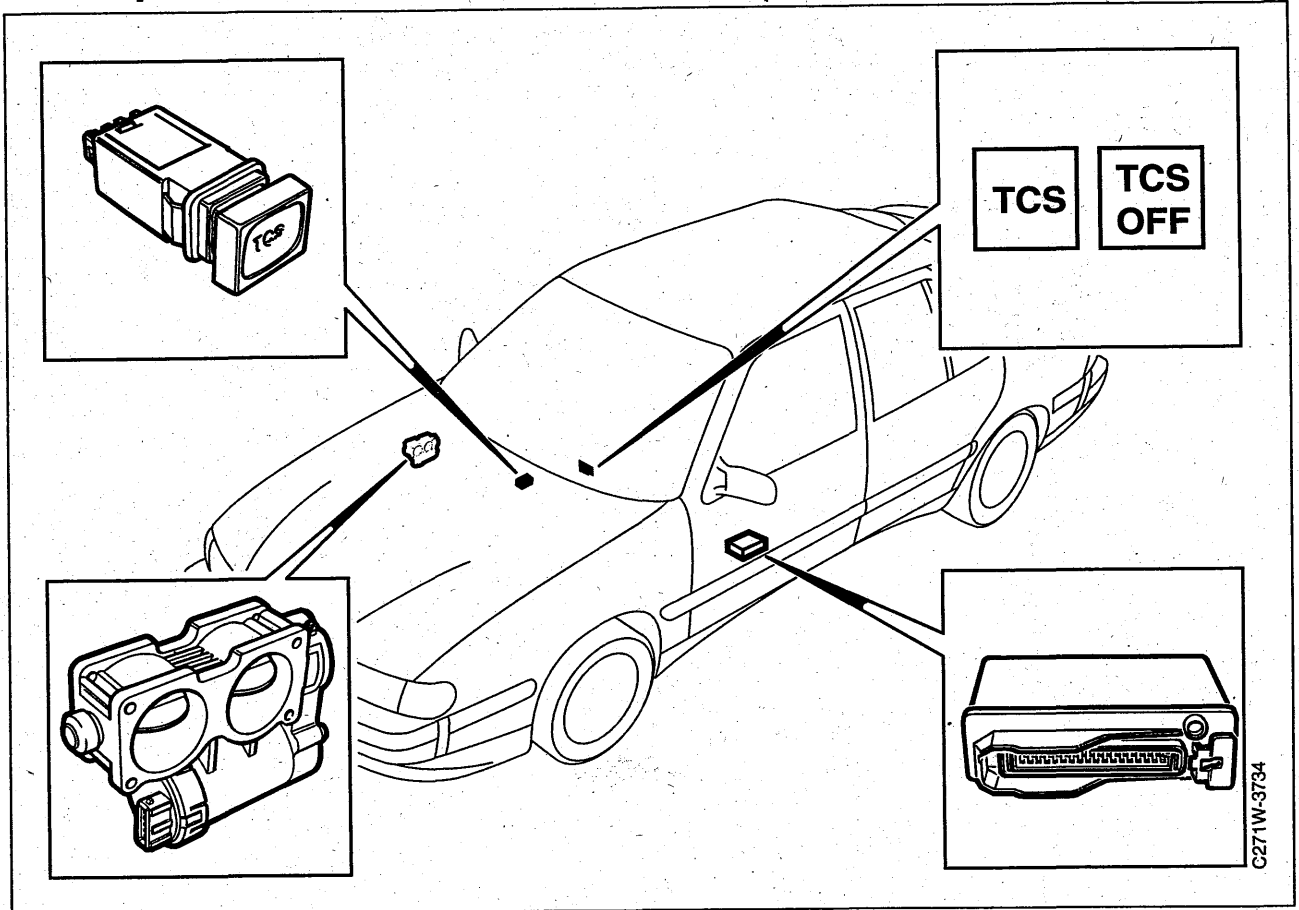

The TCS system consists of the following components:

- TCS control module
- Throttle body with direct current motor and position sensor for the TCS throttle
- TCS function lamp
- Warning lamp TCS OFF
- Switch ON/OFF

Description of TCS (contd.)

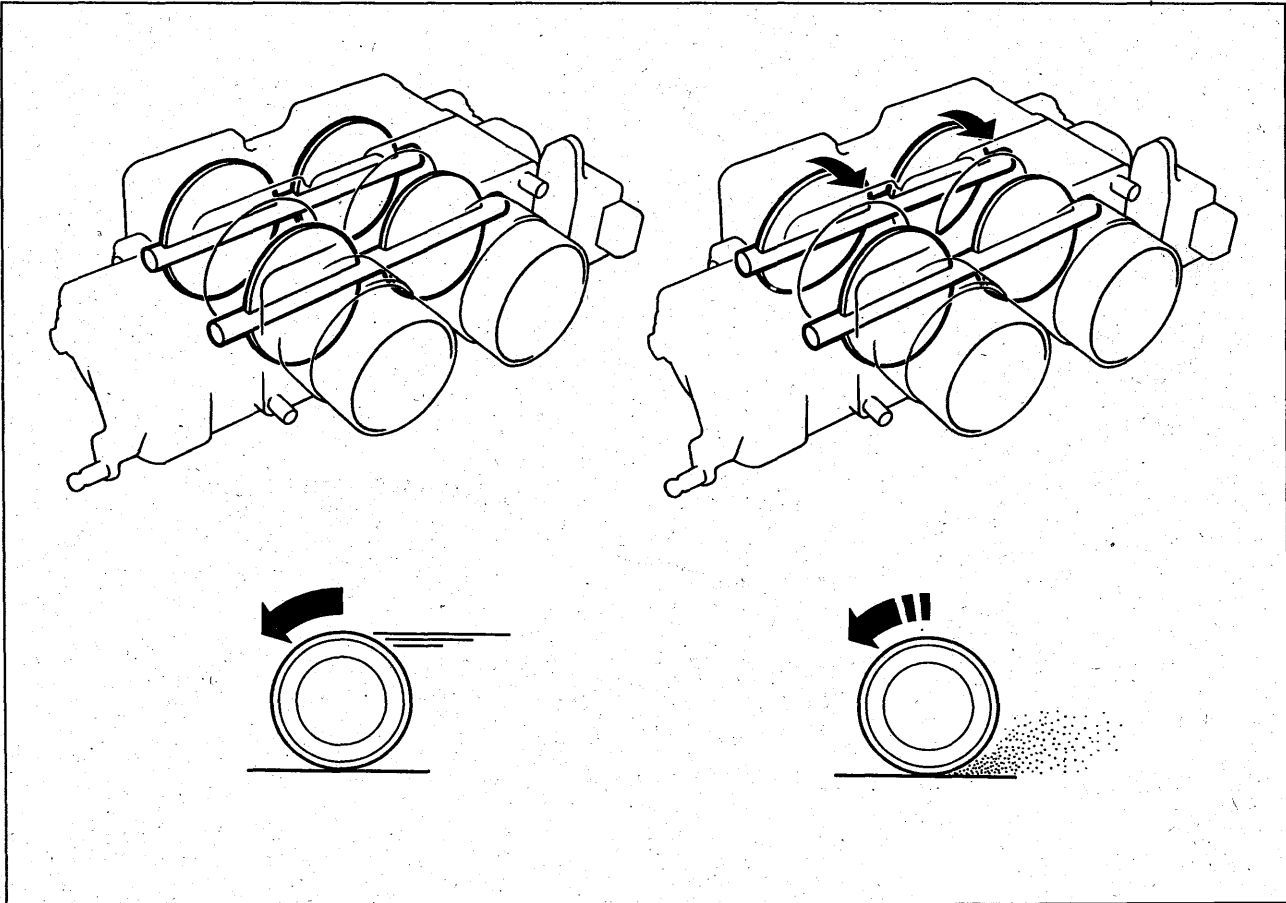

The TCS (Traction Control System) helps to prevent uncontrolled wheel spin during both fast acceleration and on slippery road surfaces.

The system is based on the double throttle principal.

This principal is called the **Twin-Throttle System (TTS)**.

This traction system controls the torque of the engine by regulation of the throttle butterfly in the extra throttle body which forms part of the system.

The extra TCS throttle body is mounted beside the ordinary wire-operated throttle body. When the car is in motion, the TCS throttle follows the ordinary throttle and is controlled by the TCS control module.

As soon as maximum permitted wheelspin is exceeded, the TCS throttle opening angle is decreased in comparison to that of the throttle, at which point the engine torque is reduced until the wheelspin ceases.

The most important information to the control module comes from the four wheel sensors via the ABS control module, but the TCS has no influence on the braking system. In order to compensate for normal changes in the diameter of the wheels, the system is adaptive to tire wear etc.

"Mini Spare" spare wheels can be used with the TCS function retained.

Description of TCS (contd.)

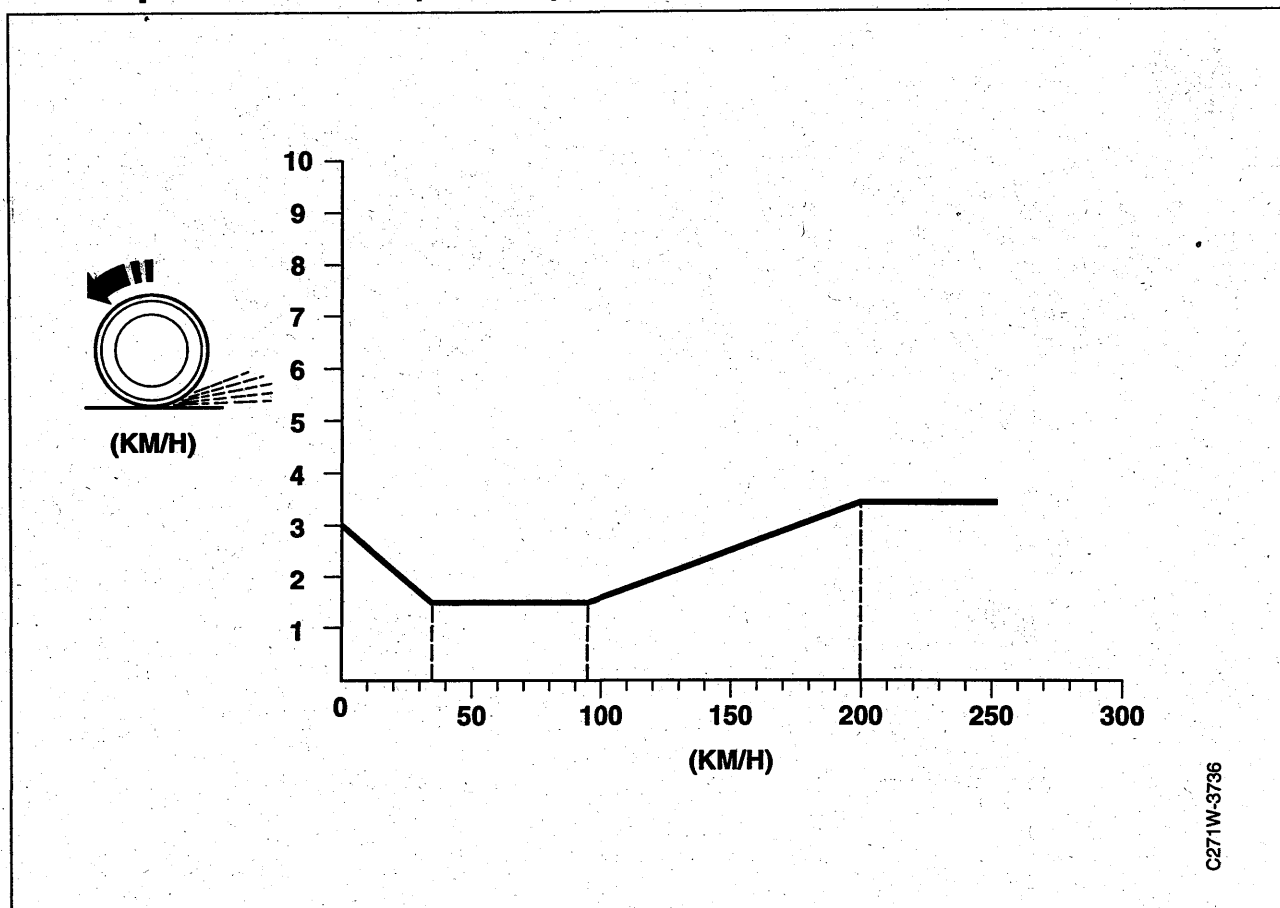
**Permitted spin**

When starting on a slippery surface, the TCS allows a maximum wheel spin of 3 km/h. The upper limit for permitted wheel spin then decreases successively to approx. 1.5 km/h at 35 km/h, which is equivalent to a wheel spin of approx. 4.5%.

Permitted wheel spin is then constant up to 100 km/h.

Over 100 km/h the permitted wheel spin increases again and reaches approximately 3.5 km/h at 200 km/h, equivalent to a wheel spin of approximately 1.8%.

At speeds over 200 km/h permitted wheel spin is again constant.

Description of TCS (contd.)

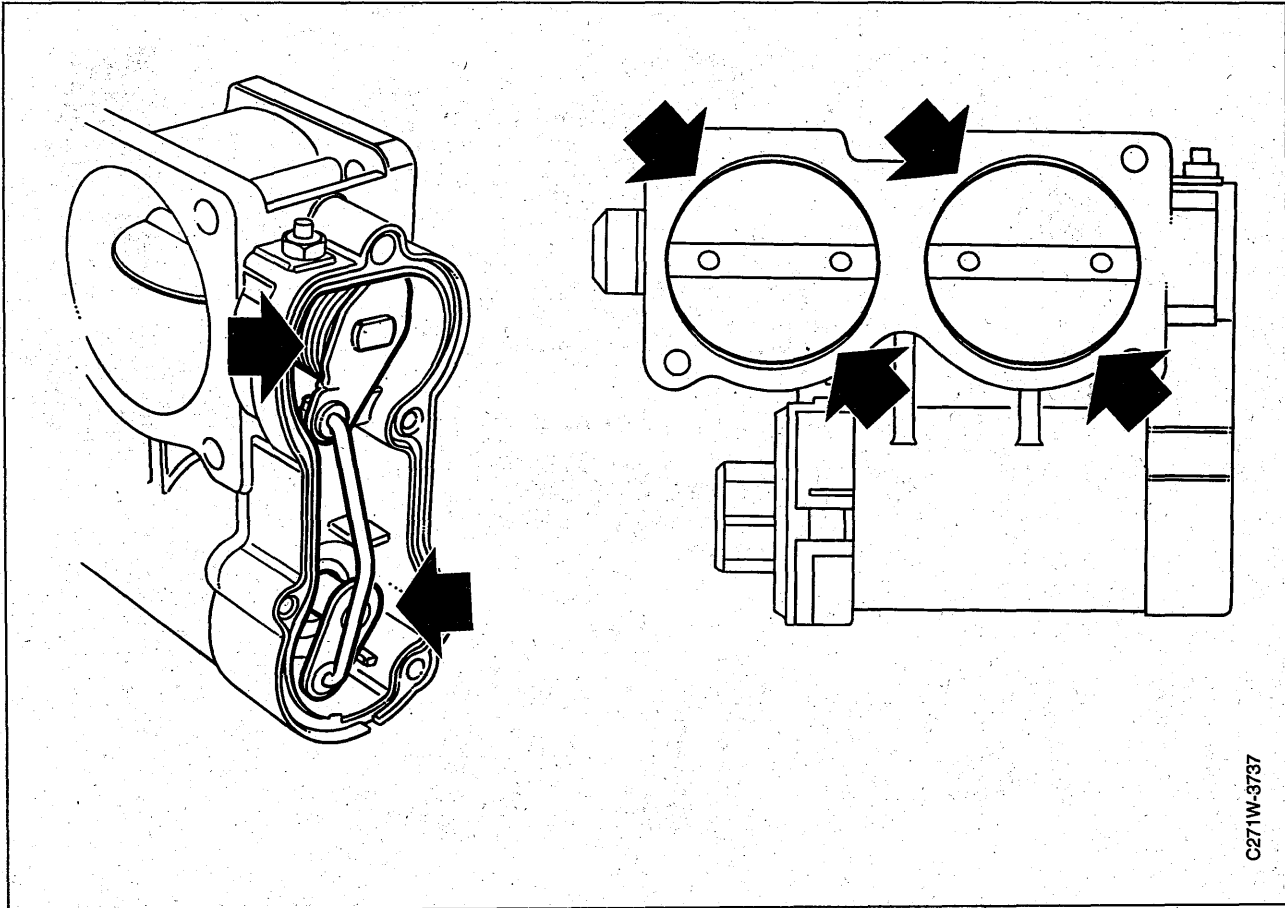

Control of throttle function

To control and synchronize the TCS throttle in relation to the ordinary throttle, a special control program is incorporated in the control module. The control covers calibration of the throttle butterfly fully open and fully closed positions, function and strength of the spring that returns the throttle butterfly to the fully open position and that the throttle butterfly moves friction-free.

Further information on the control module's calibration of the throttle butterfly position can be found under "Control module" on page 12

Functions and components

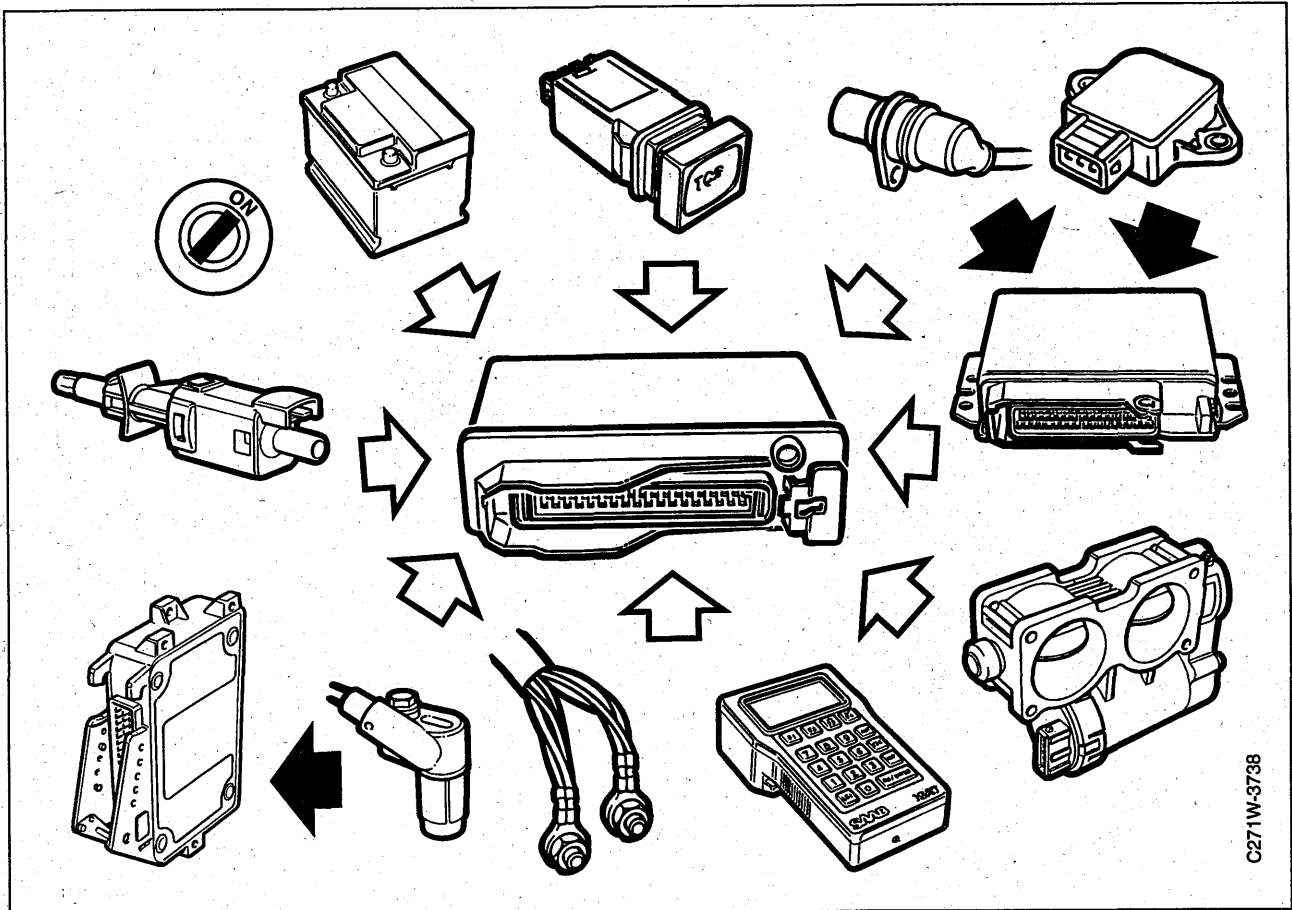

C271W-373B

Input signals to the control module

- Switch, ON/OFF (pin 1), page 18
- Engine speed signal (pin 6), page 23
- Speed signal, FR (pin 7), page 22
- Speed signal, RR (pin 8), page 22
- Speed signal, RL (pin 24), page 22
- Speed signal, FL (pin 25), page 22
- Position signal, main throttle butterfly (pin 11), page 21
- Position sensor, TCS throttle butterfly (pin 27), page 19
- Diagnostics lead K (pin 9), page 15*)
- Brake light switch (pin 23), page 24
- Voltage from +15 (pin 28), page 13
- Voltage from +30 (pin 32), page 13
- Ground (pins 13 and 30), page 14

*) also output signal

Functions and components (contd.)

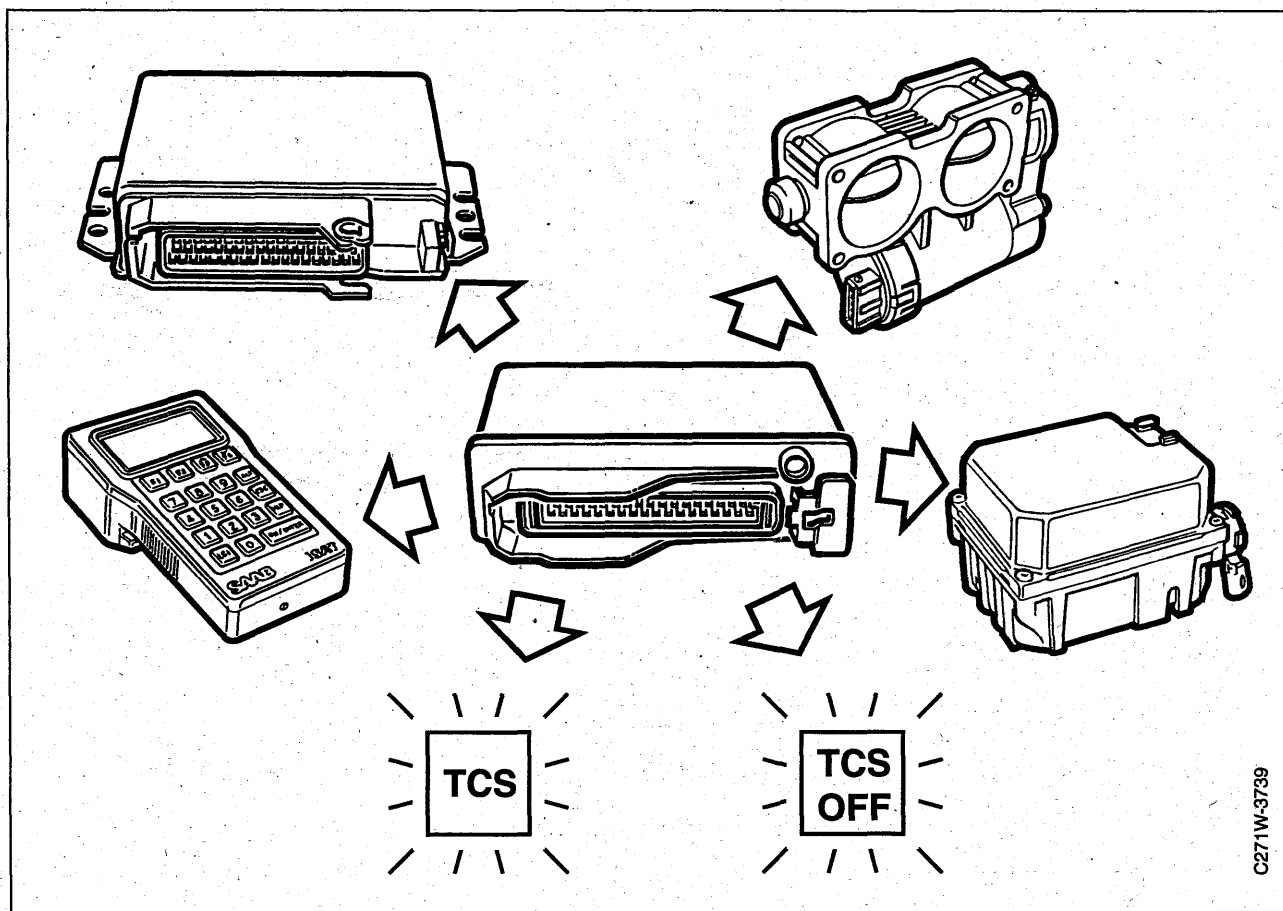

C271W-3739

Output signals from the control module

- Position sensor, TCS throttle butterfly (+) (pin 3), page 20
- Position sensor, TCS throttle butterfly (-) (pin 20), page 20
- Disconnection, cruise control (pin 5), page 25
- Disconnection, full-load enrichment system (pin 21), page 21
- TCS function lamp (pin 12), page 16
- TCS OFF warning lamp (pin 26), page 17
- Diagnostics, K lead (pin 9), page 15*
- TCS throttle butterfly actuator motor (+) (pin 18), page 20
- TCS throttle butterfly actuator motor (-) (pin 35), page 20

*) also input signal

Control module, description of function

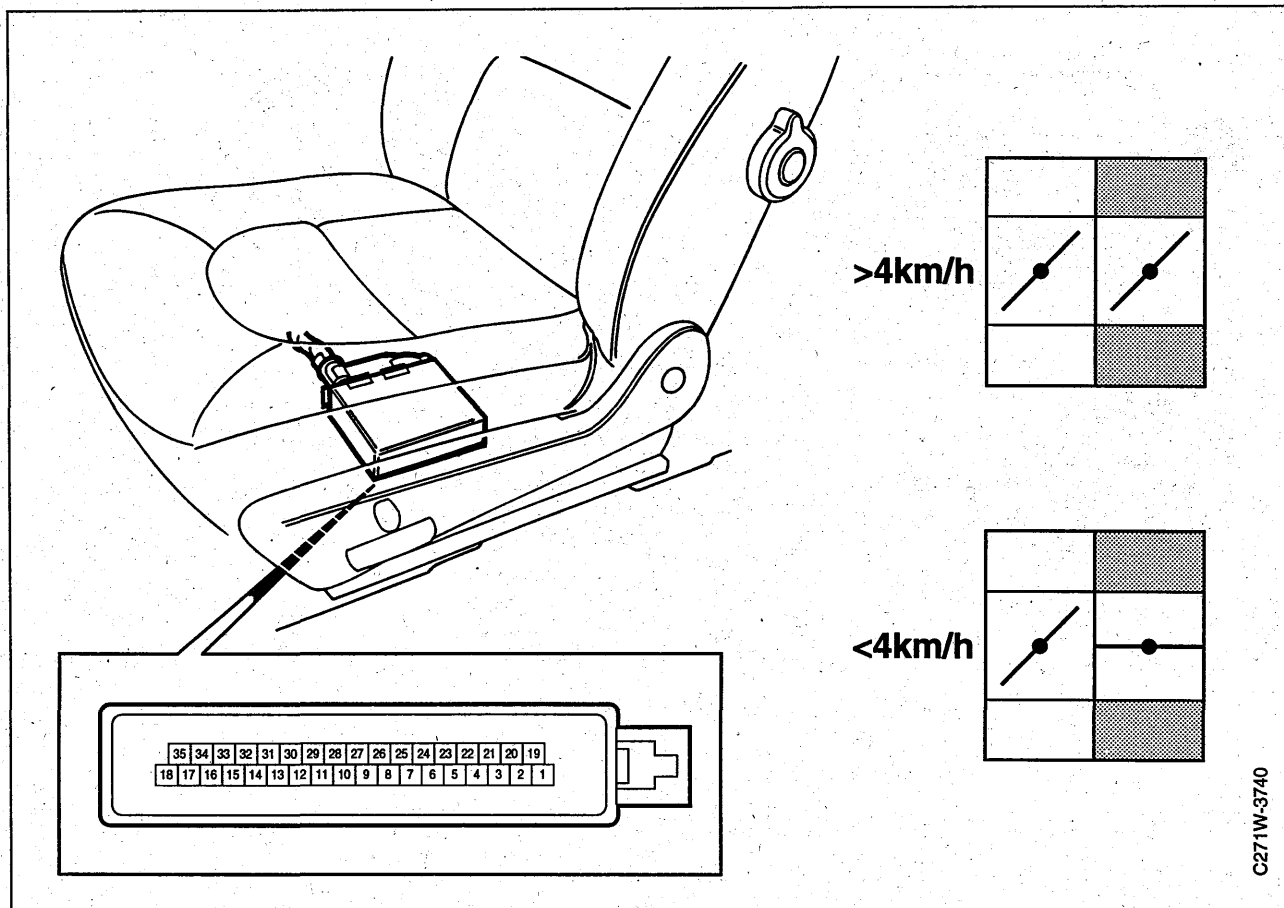

TCS control module

The TCS control module has a 35 pin connector and is located under the left-hand front seat, which is moved forward in order to make the control module accessible for removal.

When the TCS throttle butterfly actuator motor is without current, the butterfly is held in the open position by a spring.

When the ignition is placed in the drive position, the actuator motor turns the throttle **towards** the fully open position for 128 ms and in doing this makes sure that the butterfly really is **fully open**. The actuator motor is then without current (while the butterfly is held fully open by the spring) and after a further 128 ms the value from the butterfly position sensor is stored in the control module as "fully open butterfly".

As soon as the car's speed exceeds 4 km/h and the engine speed exceeds 600 rpm, the TCS throttle is synchronized with the ordinary throttle provided that the system is not manually switched off and that wheelspin does not occur.

After starting, at the point of the first engine braking with fully released accelerator pedal, a new control of the function of the TCS throttle is made, and the throttle closes completely for 128 ms. This value is then stored in the control module as "fully closed

butterfly". With the accelerator pedal still fully released, the actuator motor is without current for 256 ms, during which time the butterfly should open with spring power to at least 25° throttle valve angle. After this the TCS throttle is once again synchronized with the ordinary throttle.

With the ignition off or when there is a fault in the system, the current to the actuator motor is immediately broken and the butterfly opens completely with spring power.

When there is an internal fault in the control module, a diagnostic trouble code is registered, the TCS OFF light goes on and the TCS system is switched off.

As a spare part, the control module is unprogrammed and must therefore be programmed during installation using the ISAT. For the Saab 9000, the TCS control module is programmed according to the type of gearbox in the car, manual or automatic.

Important

A previously used control module may be programmed for the wrong type.

Control module, description of function (contd.)

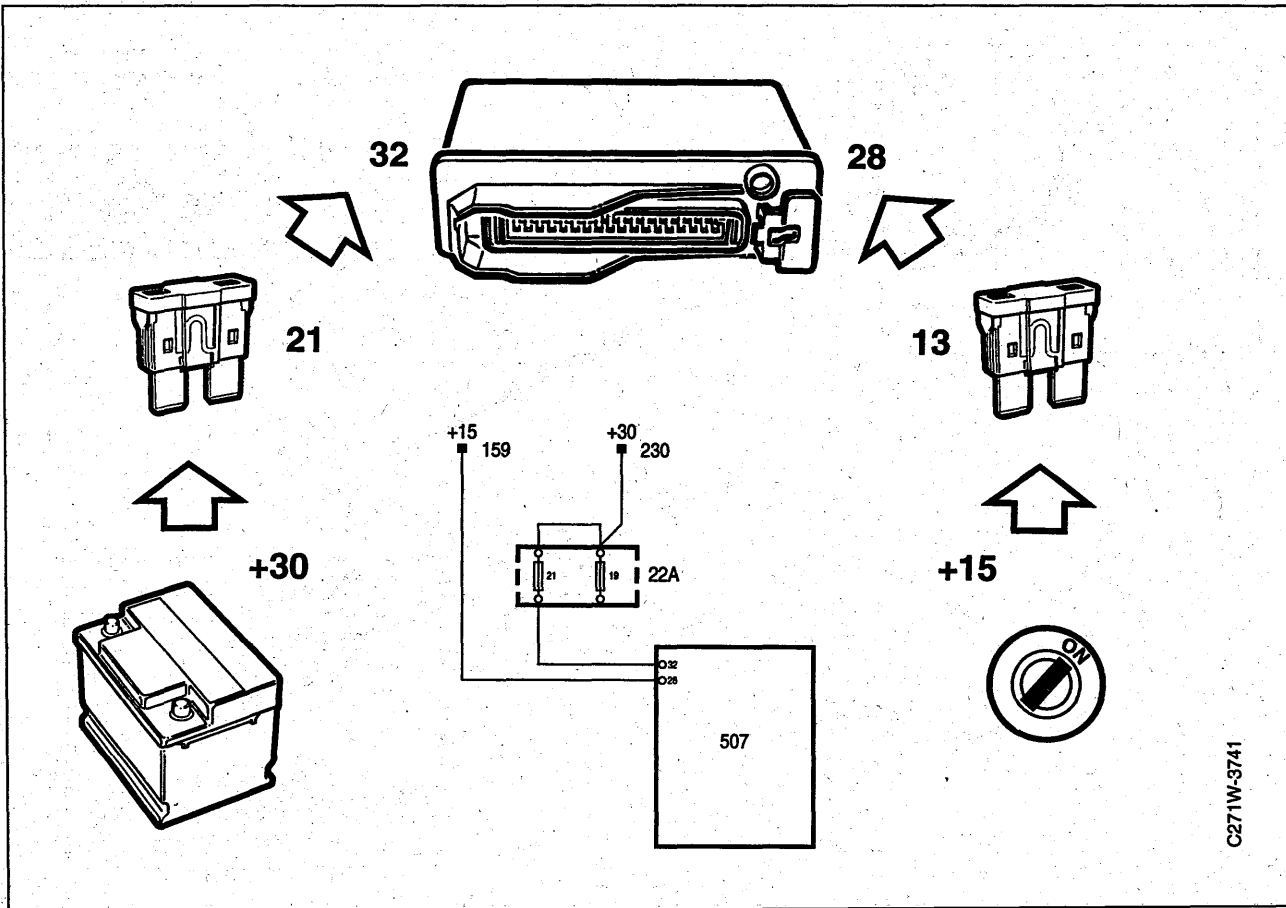

Control module voltage supply

Battery voltage +30

From fuse 21, +30 is supplied to pin 32 on the control module. The voltage is used by the control module to feed the throttle actuator motor.

If the +30 voltage is absent, the TCS OFF lamp lights and the system is switched off. If the +30 voltage should break, the control module will retain any diagnostic trouble codes stored in the memory.

Battery voltage +15

With the ignition key in the ON position, +15 is fed to pin 28 on the control module via fuse 13. The voltage is used to activate the system.

Control module, description of function (contd.)

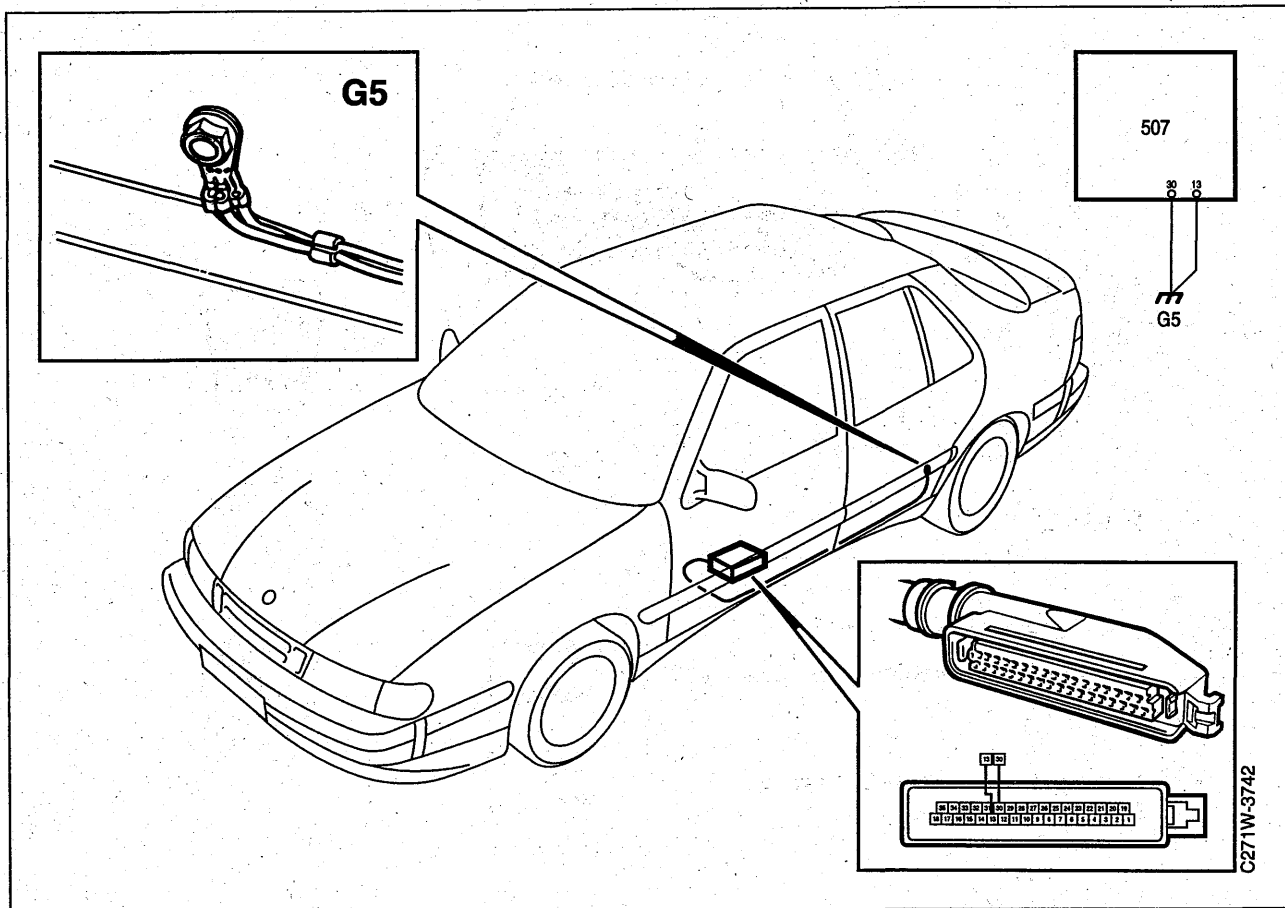

Grounding points

Pins 13 and 30 in the control module are grounded to grounding point G5. Pins 13 and 30 are internally linked in the control module and are electrically the same point. The grounding points are doubled to increase safety.

Function description of diagnostics

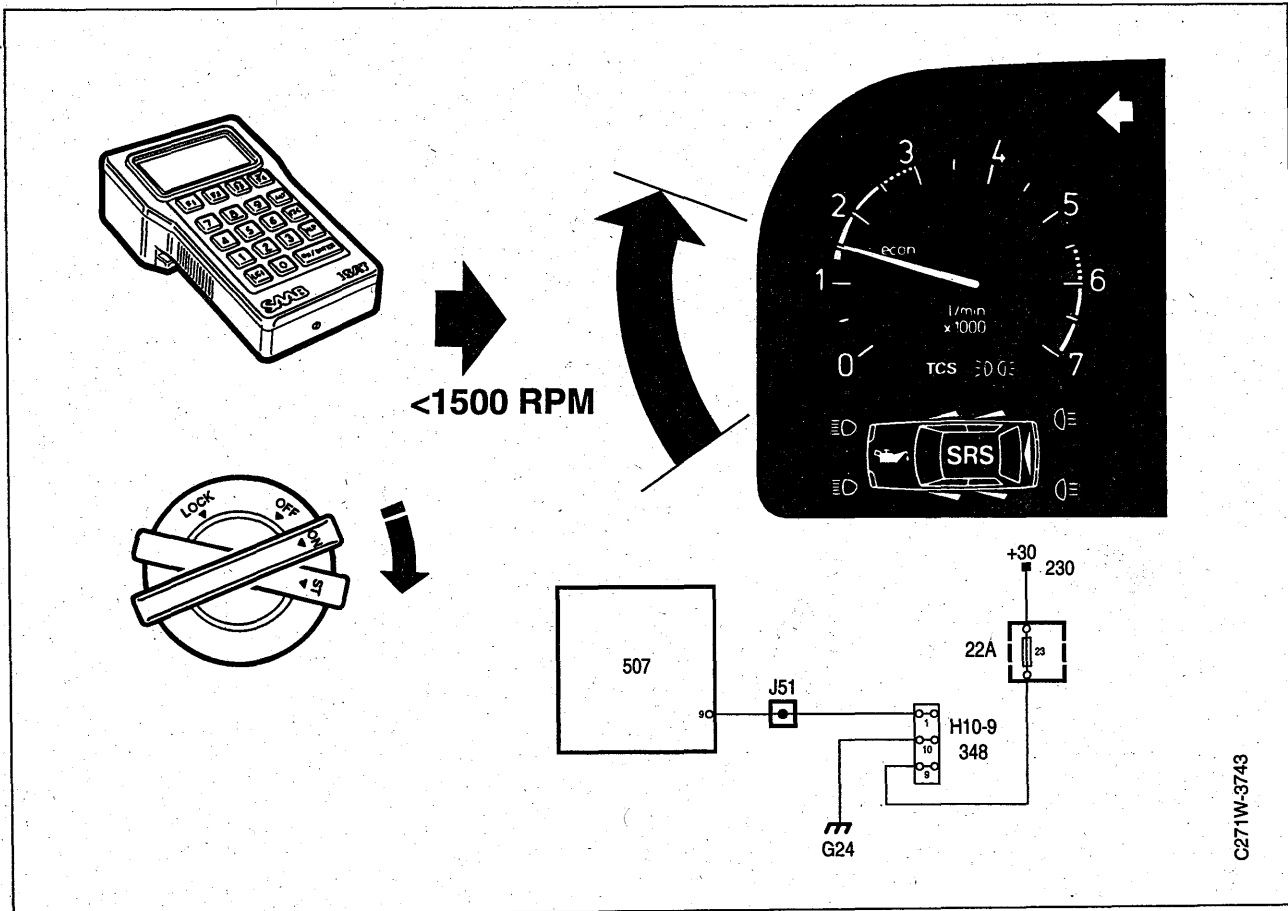

C271W-3743

ISAT diagnostics

The TCS control module is linked to ISAT via pin 9
 The link is dual-directional and has both input and output signals.

The data link connector is in front of the right-hand front seat.

With the ignition in the drive position, the voltage on pin 9 is the same as the battery positive while the ISAT is connected, and 0 Volts when the ISAT is not connected.

In order to enable communication between the ISAT and the TCS control module:

- the ignition should be in the ON position.
- the engine speed should be <1500 rpm (if the engine is running)

TCS function lamp, description of function

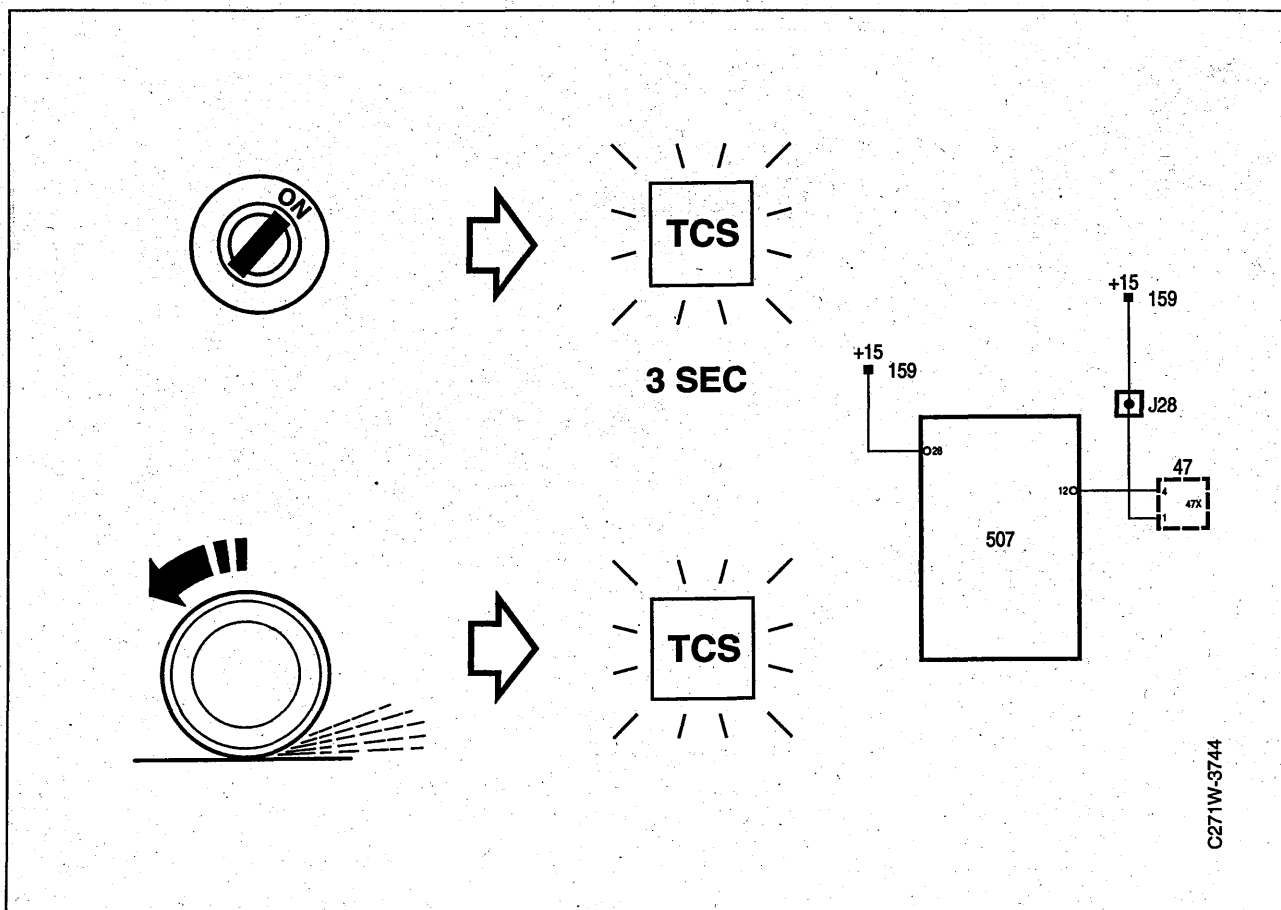

TCS function lamp

When the ignition is placed in the drive position, the function lamp lights for 3 seconds.

In the case of wheelspin that requires a reduction of more than 7% in the engine torque, the function lamp lights after a short delay (360ms). However, in the case of torque reduction greater than 30% the lamp lights without delay. The function lamp is then lit as long as the system is working, up to a maximum of 1 second.

The function lamp is lit by the control module grounding pin 12.

TCS OFF warning lamp, description of function

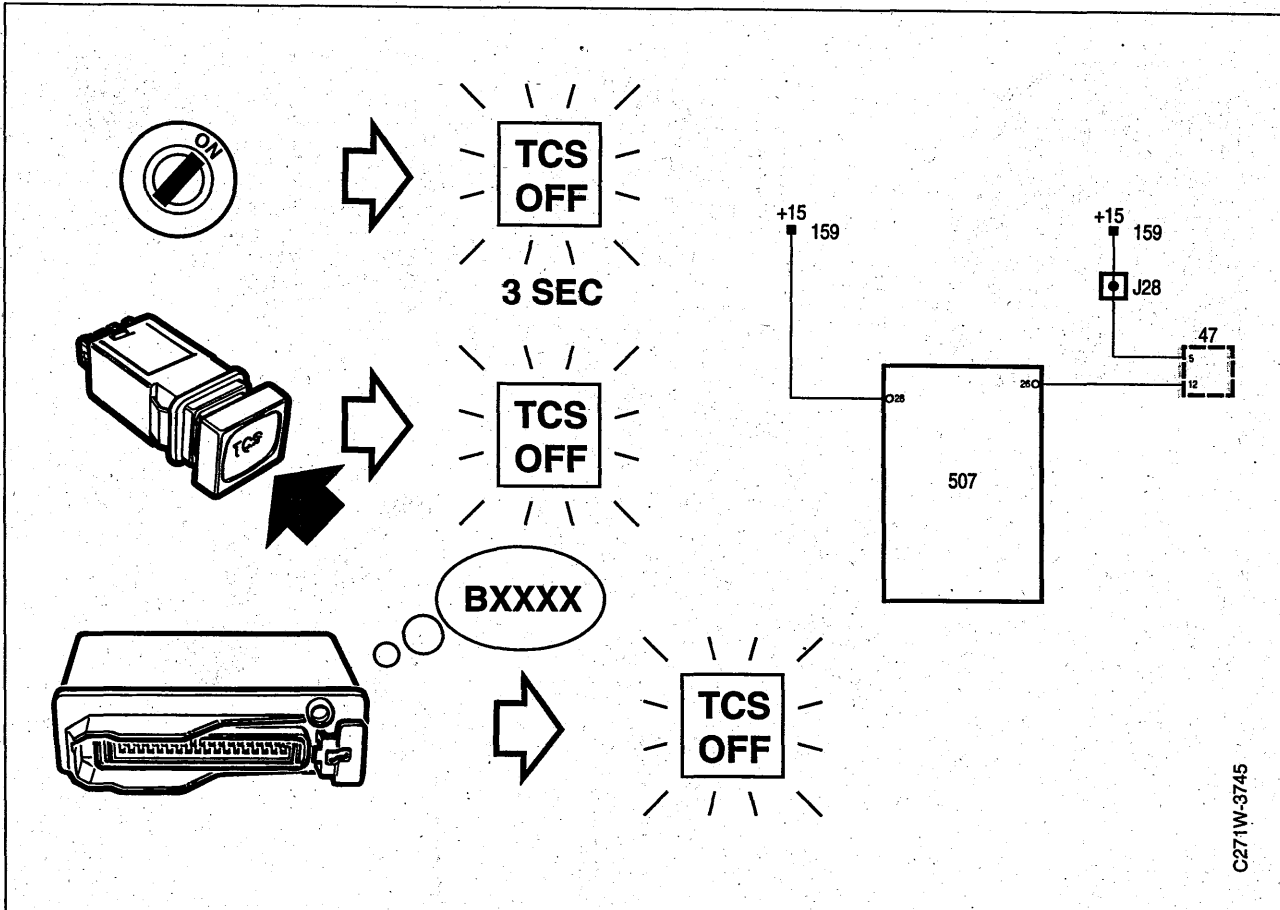

Warning lamp TCS OFF

When the ignition is placed in the drive position, the warning lamp lights for 3 seconds.

In the case of a fault in the system, the warning lamp stays lit and is lit by the control module grounding the lamp circuit in pin 26.

The warning lamp is also lit when the system is manually disengaged, which can be done at speeds under 60 km/h by pressing in the TCS switch. The system can be engaged at any speed by pressing the TCS button, at which point the TCS OFF lamp goes out.

At ignition ON when starting, the system is always engaged automatically.

ON/OFF switch, description of function

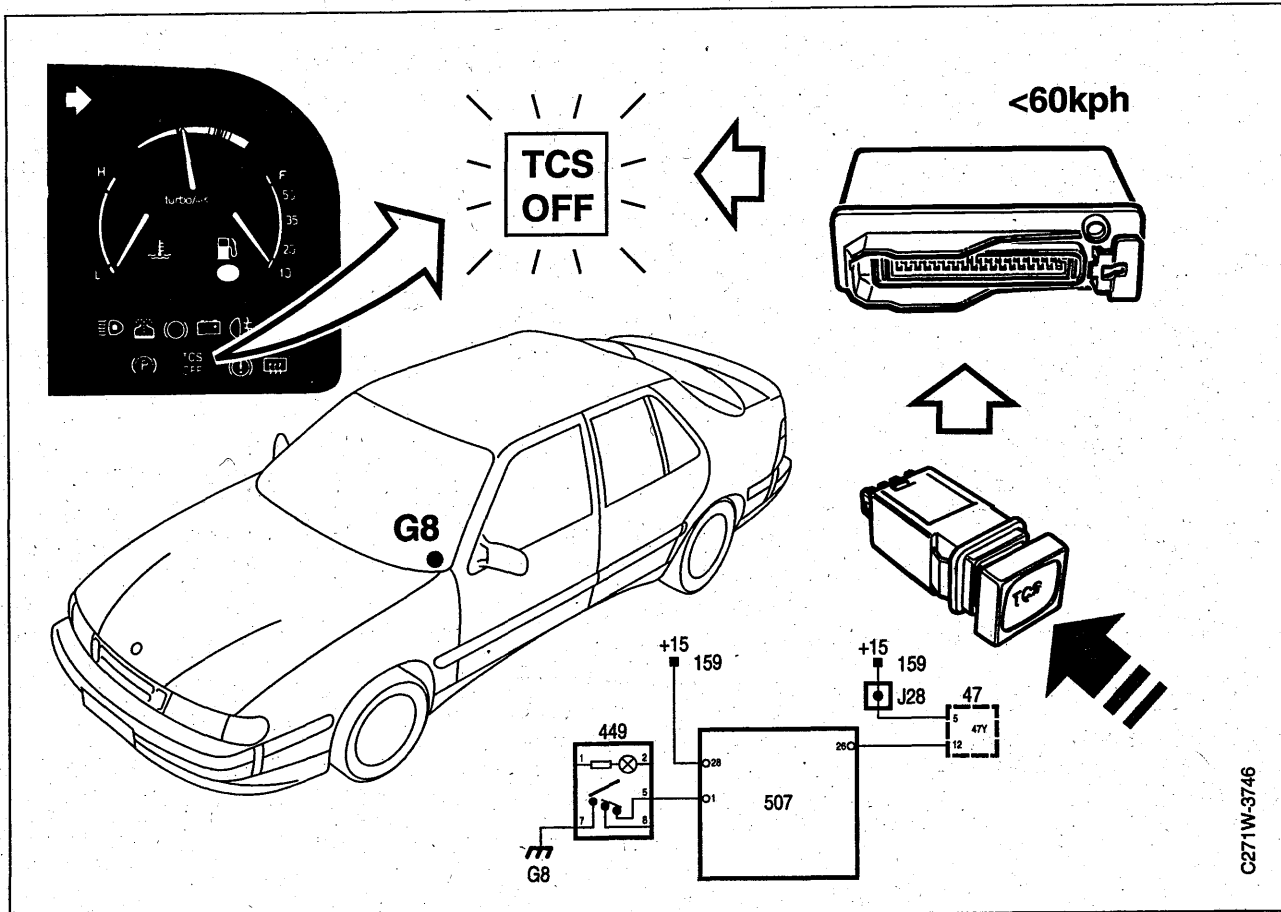

C271W-3746

Switch ON/OFF

Important

The push-button switch is of the spring-loaded type. The TCS switch has two connections, one to pin 1 in the control module and the other to ground. When the button is pressed in, the circuit is closed and the system engaged or disengaged depending on position. The TCS OFF lamp shows whether the system is engaged or disengaged.

The switch can be used to disengage the system at speeds lower than 60 km/h or to engage the system at any speed.

When the control module is switched off, the circuit to the throttle motor is broken and the TCS throttle is therefore fully open.

If the circuit to pin 1 on the control module is shorted to ground, a diagnostic trouble code is registered and the system cannot be disengaged. The same diagnostic trouble code is also registered if the TCS switch is held in for more than 10 seconds.

The system is always engaged when starting as the ignition is turned to the drive position.

TCS throttle body, description of function

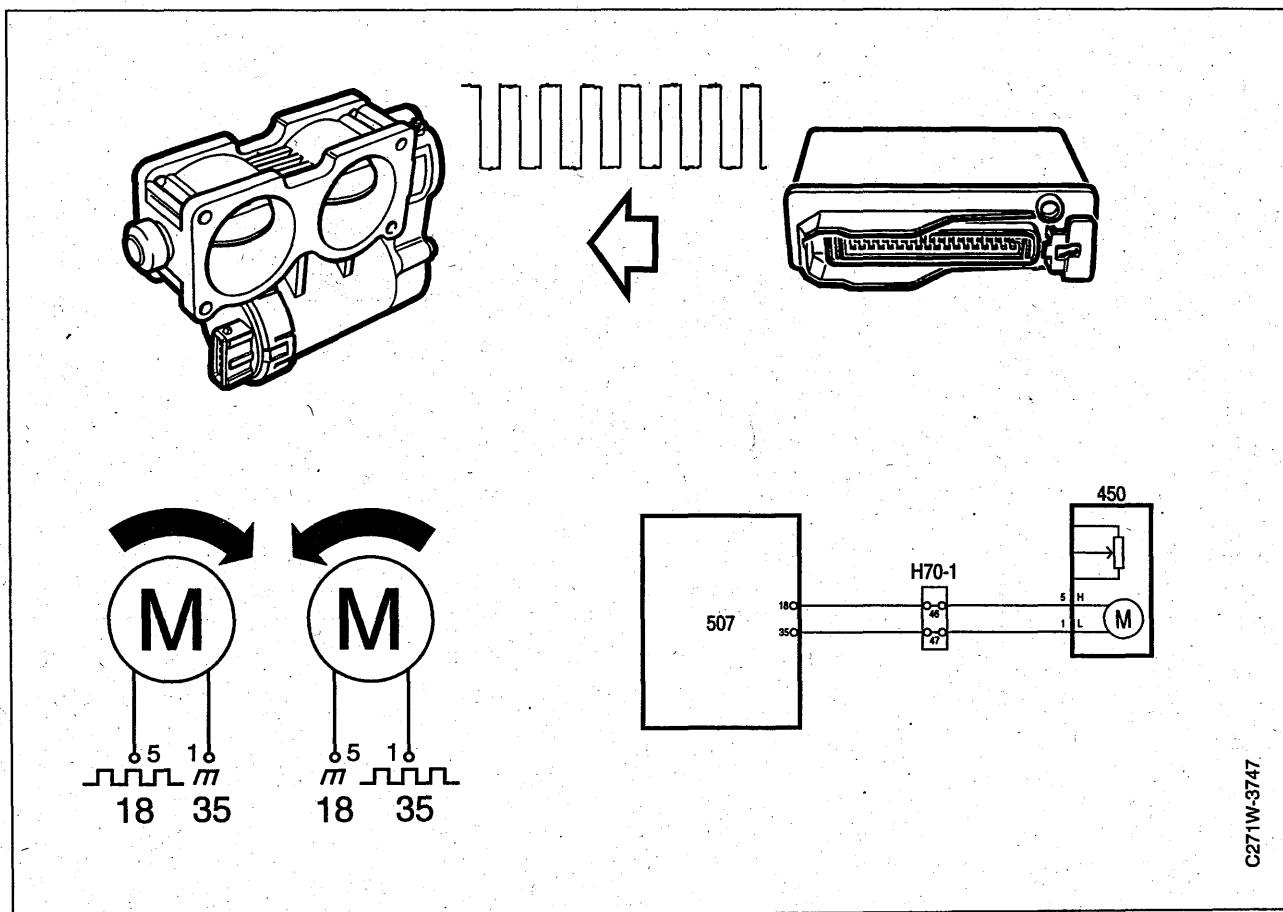

C271W-3747

The TCS throttle body is mounted beside the ordinary throttle body and consists of body, butterfly, electric motor and link arm. In the TCS OFF mode, the current is cut and the throttle is opened by a spring.

Important

The TCS throttle must not be adjusted.

Feed to butterfly actuator motor

The TCS butterfly actuator motor is fed voltage by a 500 Hz PWM outlet from pins 18 and 35 on the control module. The motor can be driven in both directions by changing the poles.

When the butterfly is closed, the voltage across pins 18 and 35 is approximately 3.5 Volts.

In the case of mechanical or electrical faults in the actuator motor or position sensor, or in the connecting leads, diagnostic trouble codes are registered by the system. The TCS OFF lamp lights and the system is disengaged.

As a spare part, the TCS throttle body is changed as one unit.

The TCS system is self-calibrating, see under "Control module" on page 12.

TCS throttle body, description of function (contd.)

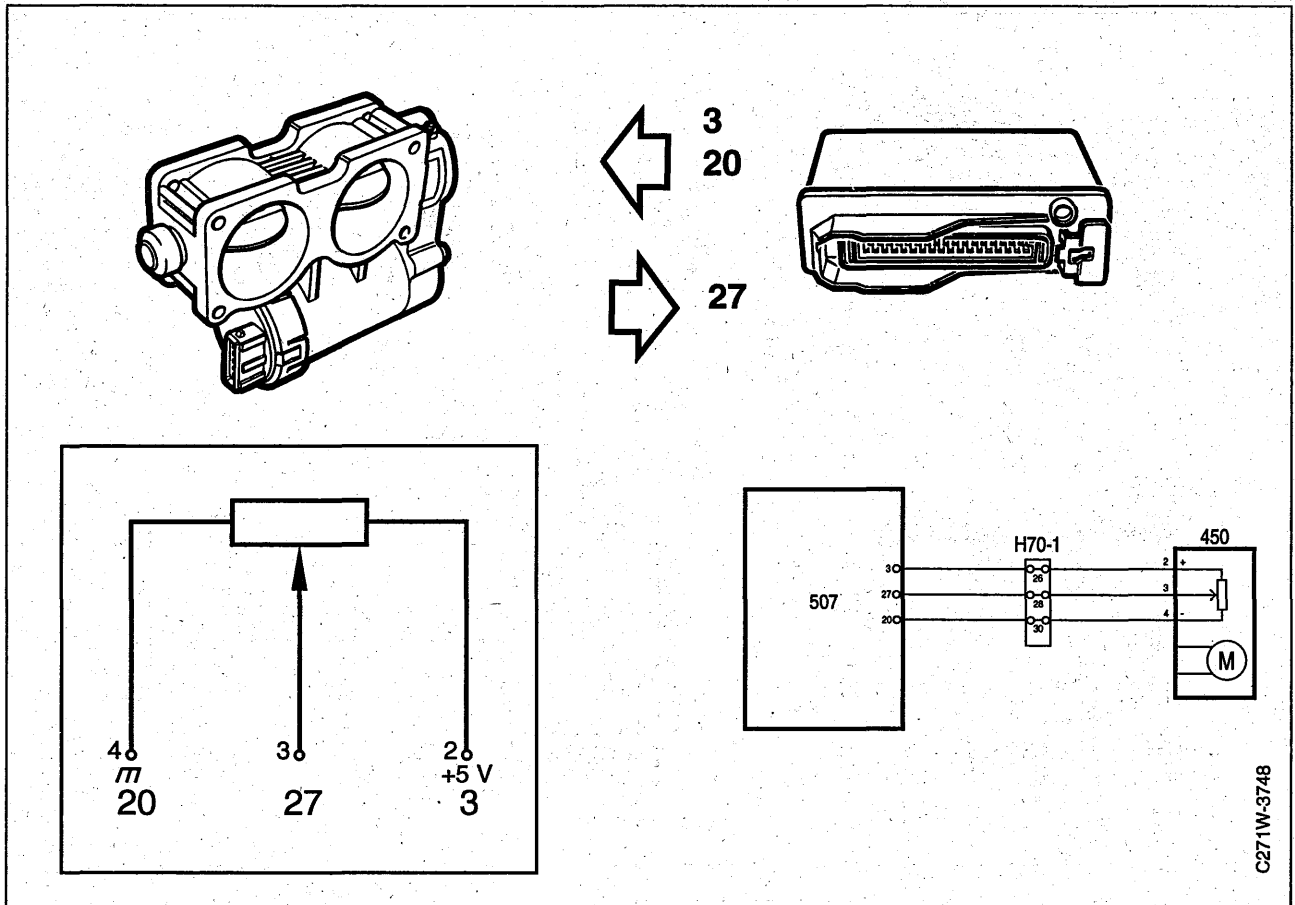

Throttle disc potentiometer

Information from the TCS butterfly position sensor is received by the control module on pin 27.

Depending on the position of the TCS butterfly, the voltage varies between approx. 1.2 — 4.4 Volts.

The position sensor is fed with 5 volts from pin 3 on the control module and is grounded via control module pin 20.

Main butterfly position signal, description of function

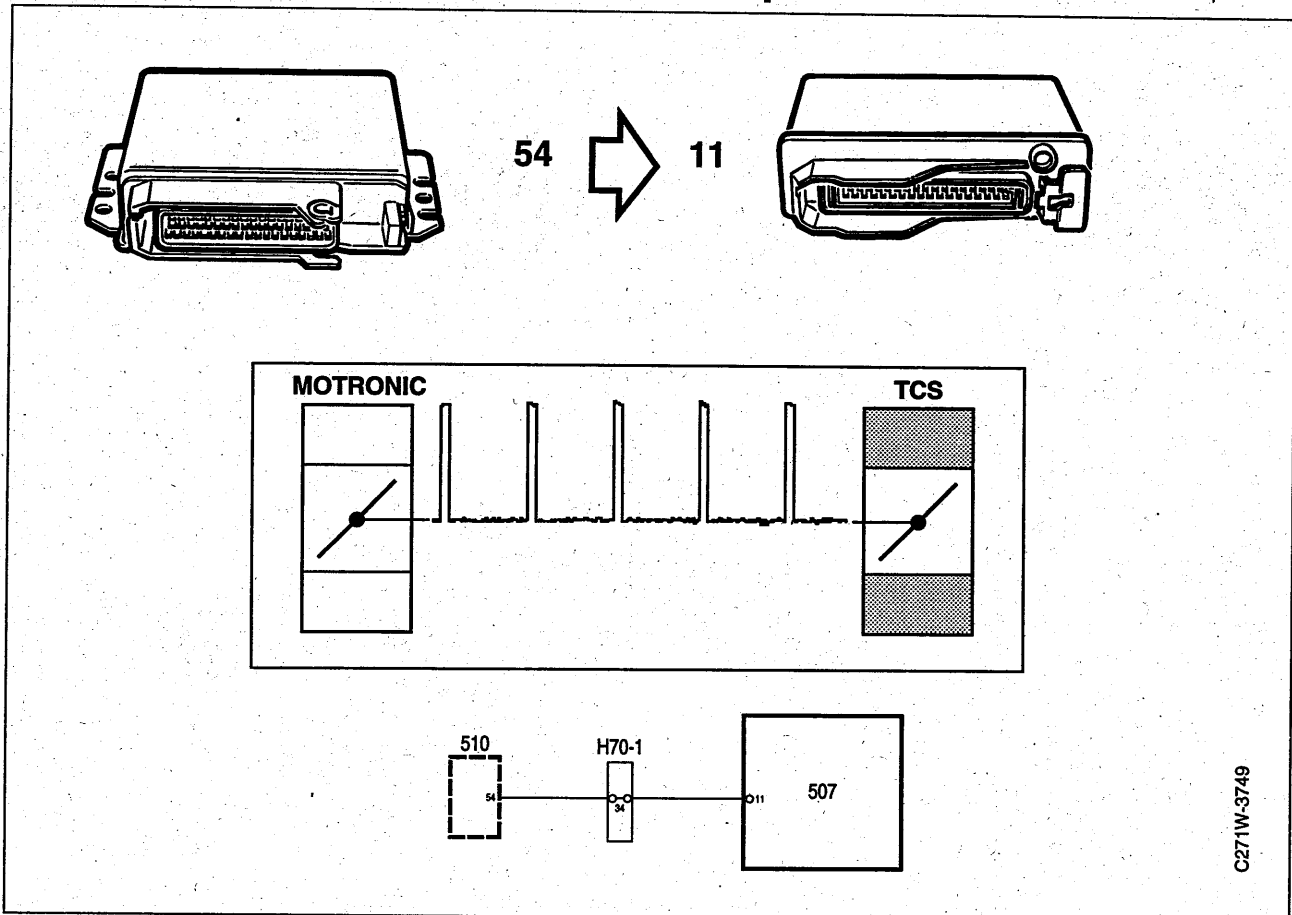

To synchronize the TCS butterfly in relation to the main butterfly, the TCS control module receives a position signal on pin 11 from pin 54 on the MOTRONIC control module. The signal, which is 100 Hz PWM, gives the position of the main butterfly and measures approx 1.2 Volts at idling.

In the case of a spurious **throttle position signal** or an interruption/short in the circuit, diagnostic trouble codes are registered by the system, the TCS OFF lamp lights and the system is disengaged.

When the ignition is switched into the drive position and when the starter motor is running, the MOTRONIC control module sends an engine temperature signal instead of a throttle position signal to pin 11 on the TCS control module.

When the engine is switched off and the ignition is in the drive position, the signal measures approx. 0.25-1.0 Volts, depending on the engine temperature.

If the **engine temperature signal** is wrong, diagnostic trouble codes will be registered in the MOTRONIC system. In this case, no diagnostic trouble code is registered in the TCS system.

See also "Disconnection, full-load enrichment system" on page 26.

Speed signals, description of function

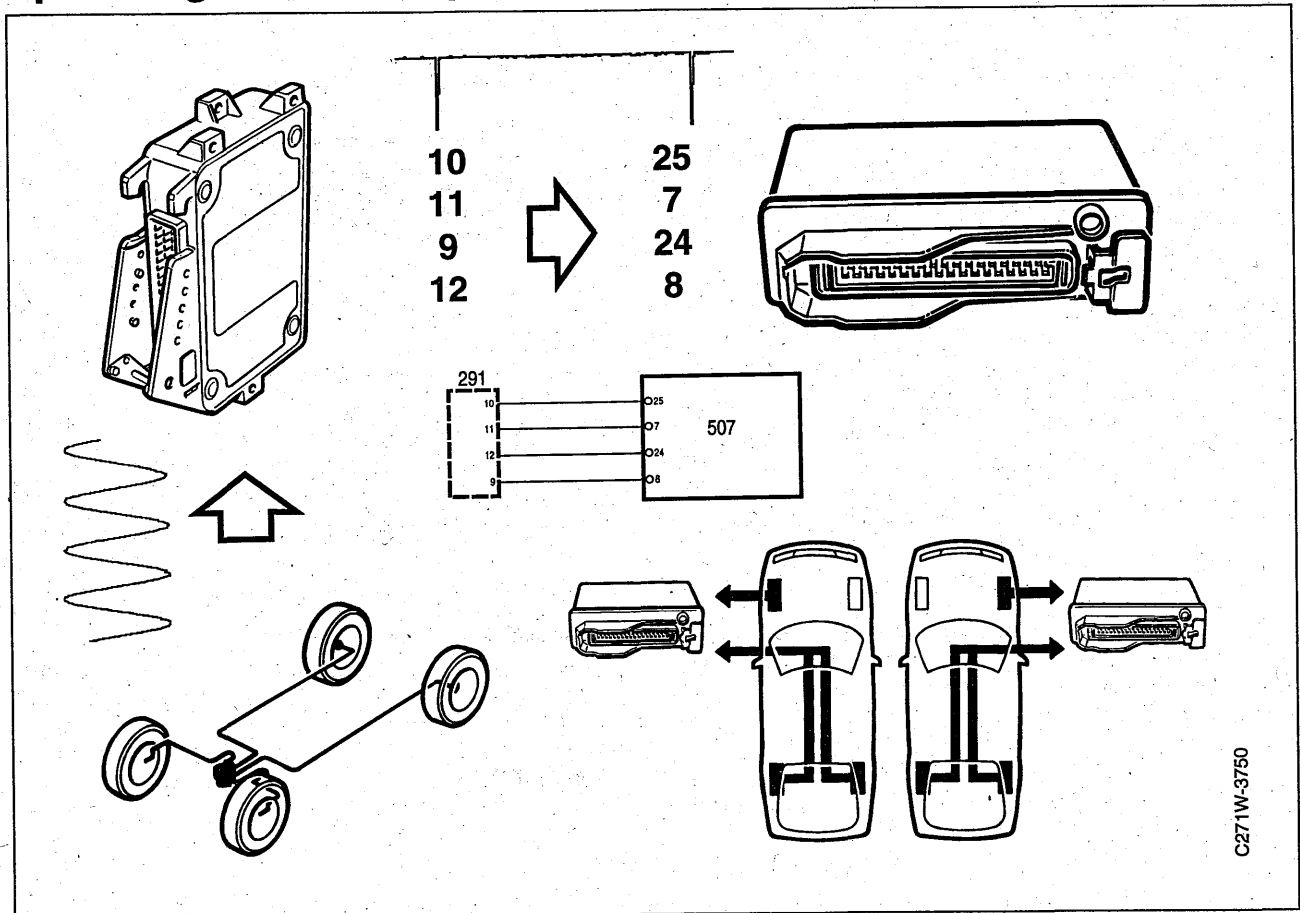

To calculate if there is wheelspin on any of the drive wheels, the control module receives information on the speed of the front wheels. The speed of the rear wheels is used as a reference, which is why this information is also received by the control module.

The wheel speed for each wheel is taken from the ABS control module as follows:

Wheel	Pin on ABS control module	Pin on TCS control module
FL	10	25
FR	11	7
RL	12	24
RR	9	8

The signal is a 60 μ s long ground pulse which the ABS control module sends 92 times per wheel rotation. When the wheels are stationary, the ABS control module sends pulses with a frequency of 14.25 Hz as a test signal.

If one or more wheels are stationary at the same time as the speed of another wheel is greater than 10 km/h, a diagnostic trouble code is registered by the system. If the fault remains for more than 20 seconds, the TCS OFF lamp lights and the system is disengaged.

The system is disengaged in the same way if the speed of any of the wheels exceeds 280 km/h.

Engine speed, description of function

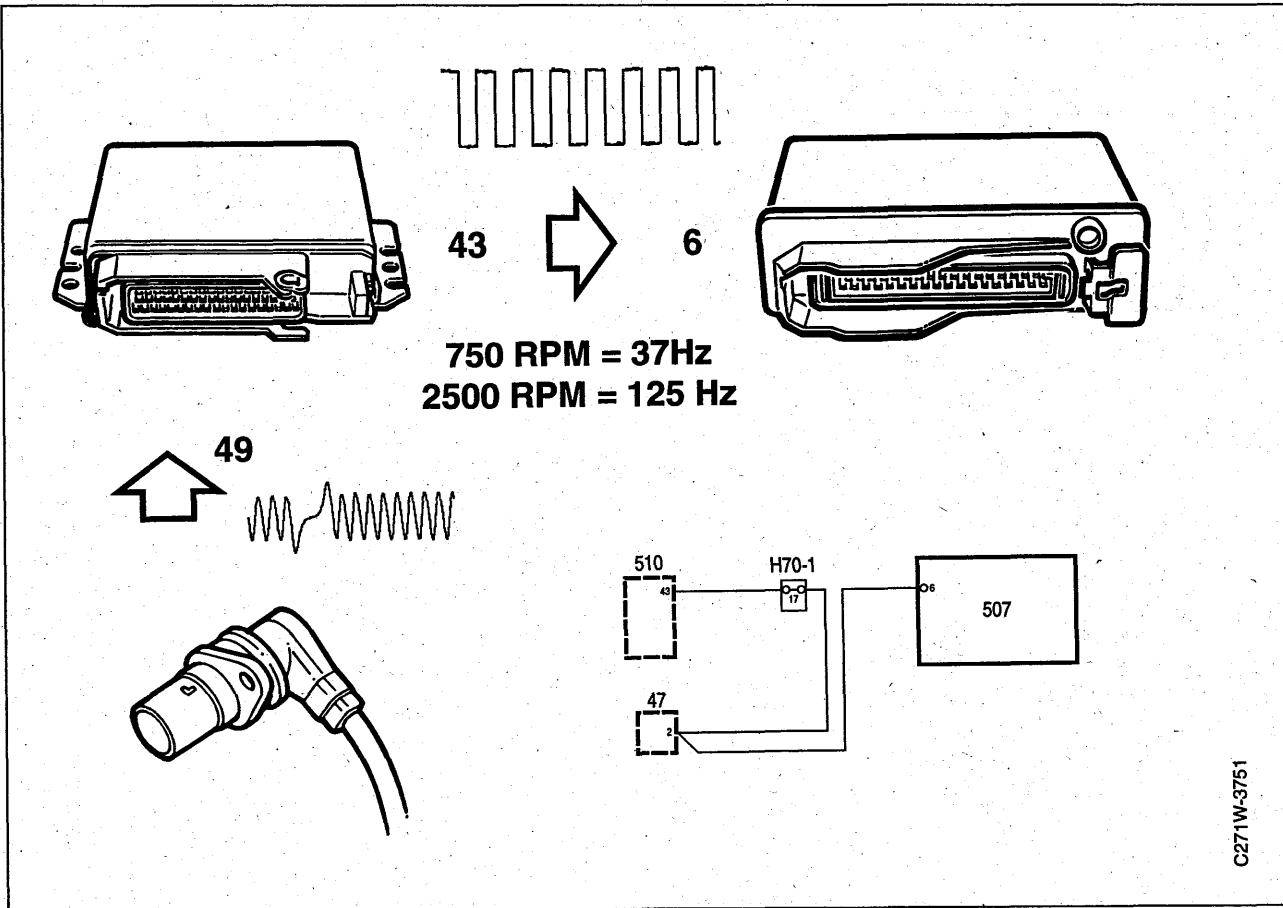

The TCS control module receives information about the current engine speed via pin 6 from pin 43 on the MOTRONIC control module.

Information about the engine speed is essential so that:

- the control module can use this and information about the positions of the main and TCS throttles to calculate the engine torque.
- the control module can use this and the speed signals from the wheels to calculate the gear positions.

The signal is a square wave of approx. 37 Hz while idling and approx. 125 Hz at 2500 rpm.

If the signal is wrong or there is an interruption/short in the circuit, diagnostic trouble codes are registered by the system. The TCS OFF lamp lights and the system is disengaged.

Input from break light switch, description of function

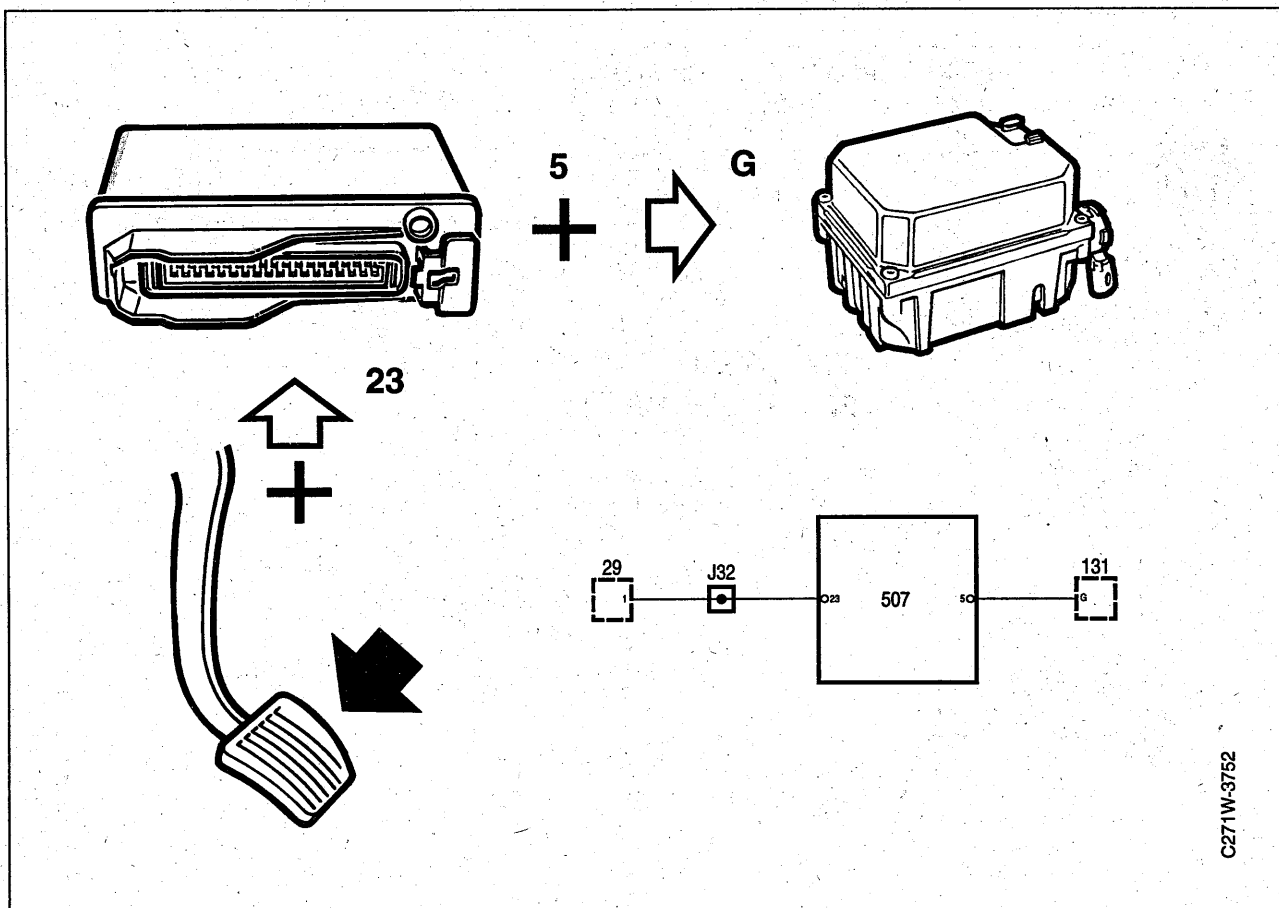

C271W-3752

When the brake is activated, the control module receives battery+ to pin 23.

The control module then sends battery+ on pin 5 and disengages the cruise control.

Disconnection of cruise control, description of function

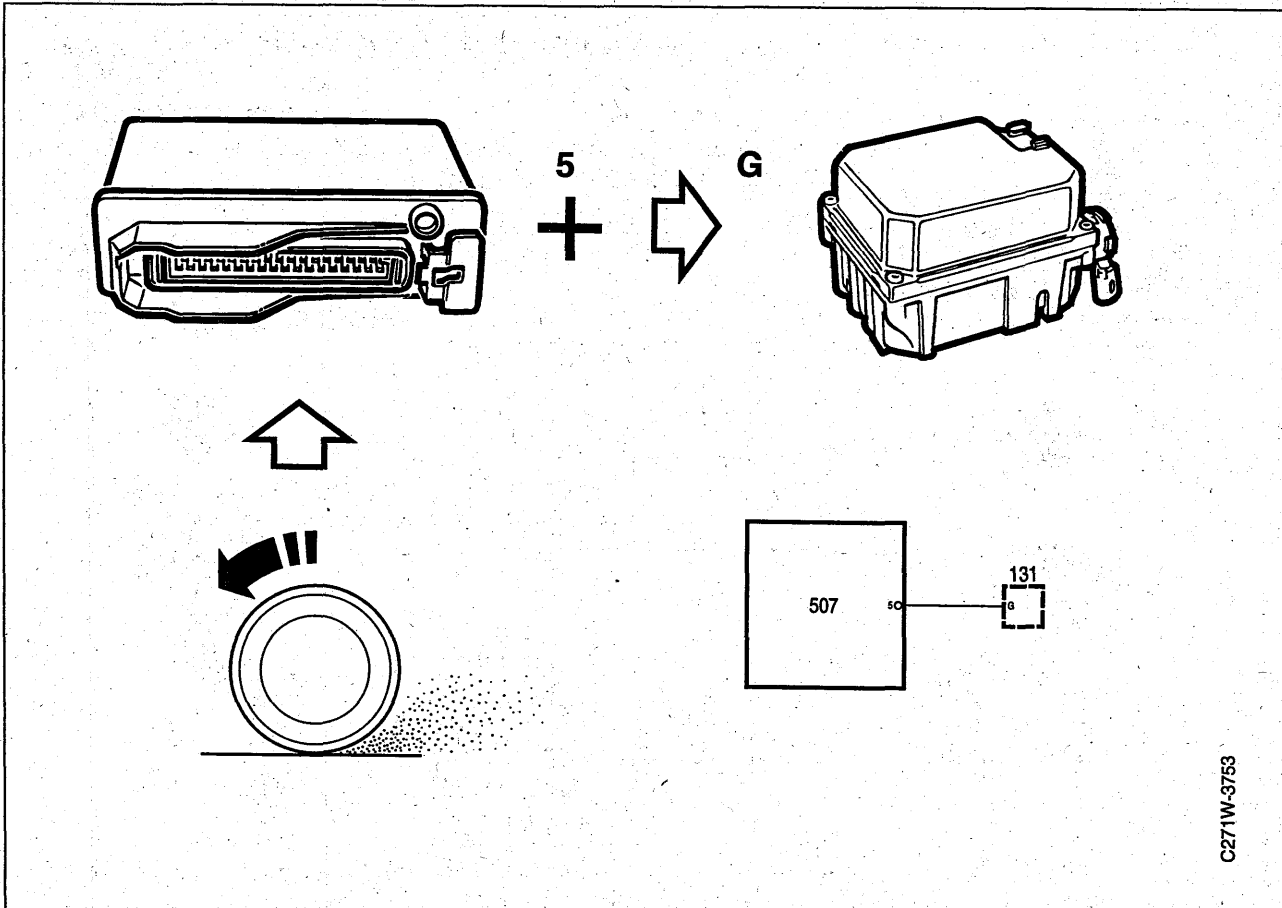

As soon as the TCS function is activated or the brake pedal is pressed, the control module sends battery+ to pin 5. The voltage goes to pin G on the cruise control and the function is switched off.

Important

When the TCS function is activated, switch-off has a delay of approx. 1 second.

Fault diagnosis TCS

Measured values, contr. module conn.	27	Fault diagnosis of functions without	
Diagnostic trouble codes	30	diagnosis trouble codes	31
		Fault diagnosis schedule	36

Measured values, control module connections

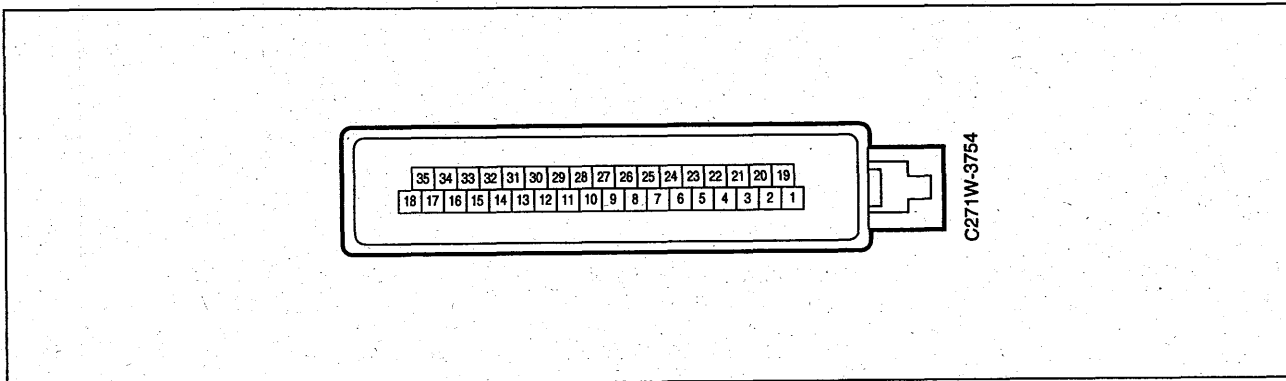

> = greater than; < = less than; ≈ = approximately equal to; ~ = alternating voltage
 Pins not mentioned are not connected.
 (LP: LOGIC PROBE P = select pulse; p = visible pulses).

Pin	Color	Component/Function	In/Out	Measuring conditions	Measured value	Between X-Y	Signal, see page
1	BK/WH	TCS OFF/ON	In	TCS switch ON (pushed in)	Batt+	32 — 1	18
				TCS switch OFF (not pushed in)	0 Volt		
2		No connection					
3	YE/WH	Position sensor, TCS throttle, reference voltage	Out		approx. 5 Volts	3 — 13	20
4		No connection					
5	RD/WH	Disengaging cruise control	Out	Activate with ISAT: ON	Batt+	5 — 13	25
				Activate with ISAT: OFF	0 Volt		
6	OG	Engine speed	In	Idling	40 Hz (LP LO HI)	6 — 13	23
7	BU	Wheel speed FR	In		14.25 Hz (LP HI LOp)	7 — 13	22
				Rotate FR wheel approx. 1/2 turn/s	46 Hz (LP HI LOp)		
8	GN	Wheel speed RR	In		14.25 Hz (LP HI LOp)	8 — 13	22
				Rotate RR wheel approx. 1/2 turn/s	46 Hz (LP HI LOp)		
9	BU/WH	Diagnostics lead K	In/Out	ISAT connected	Batt+	9 — 13	15
				ISAT not connected	0 Volt		
10		No connection					

Measured values, control module connections (contd.)

Pin	Color	Component/Function	In/ Out	Measuring conditions	Measured value	Between X-Y	Signal, see page
11	YE	Position signal, main butterfly (from MOTRONIC) Engine temp. signal (from MOTRONIC)	In	Idling	1.2 Volt 100 Hz 9% (+) 0.9 ms (+) (LP LO HI)	11 — 13	21
				Ignition ON, starter motor running	0.25-1.0 V 100 Hz 2-8.2% (+) 0.2-0.82ms (+) (LP LO HI)		
12	BN/WH	TCS lamp	Out	Activate with ISAT: ON	Batt+	32 — 12	16
				Activate with ISAT: OFF	0 Volt		
13	BK	Ground	In		< 0.1 V	13 — B minus	14
14		No connection					
15		No connection					
16		No connection					
17		No connection					
18	GN/WH	Throttle motor Important Erase any trouble codes after this test.	Out	Activate with ISAT: BUTTERFLY CLOSING ON	3.5 Volt 500 Hz 35% (+) 0.7 ms (+) (LP LO HI)	18 — 35	19
				As above + manually open throttle (max. 5 secs)	8-11 Volts		
				As above + close butterfly additionally by hand (max 5 secs)	minus 8 to minus 11 V		
19		No connection					
20	WH	Position sensor, butterfly TCS, ground	Out		Batt+	32 — 20	20
21	GY	Disengaging full-load enrichment system	Out		6 Volt 31 Hz 50% (+) 16 ms (+) (LP HIp LOp)	21 — 13	26
				TCS function activated	6 Volt 62 Hz 50% (+) 8 ms (+) (LP HI LO)		
22		No connection					

Measured values, control module connections (contd.)

Pin	Color	Component/Function	In Out	Measuring conditions	Measured value	Between X-Y	Signal, see page
23	WH	Brake light switch	In	Brakes applied	Batt+	23 — 13	24
				Brakes not applied	0 Volt		
24	GY	Wheel speed RL	In		14.25 Hz (LP HI LOp)	24 — 13	22
				Rotate RL wheel approx. 1/2 turn/s	46 Hz (LP HI LOp)		
25	YE	Wheel speed FL	In		14.25 Hz (LP HI LOp)	25 — 13	22
				Rotate wheel FL approx. 1/2 turn/s	46 Hz (LP HI LOp)		
26	VT/WH	TCS OFF lamp	Out	Turn off the TCS system using switch: lamp LIT	Batt+	32 — 26	17
				Activate TCS sys- tem using switch: lamp OFF	0 Volt		
27	BU/WH	Position sensor, butterfly TCS, outlet	In	Activate with ISAT: BUTTERFLY CLOSING ON	approx. 1.2 V	27 — 13	20
				Activate using ISAT: BUTTER- FLY CLOSING OFF	approx. 4.4 V		
28	GN/WH	+15 voltage	In		< 0.5 Volt	B.plus 28	13
				Ignition OFF	Batt+		
29		No connection					
30	BK	Ground	In		< 0.1 Volt	30 B.minus	14
31		No connection					
32	RD	Voltage supply	In		<0.5 Volts	B.plus 32	13
33		No connection					
34		No connection					
35	GN	Throttle actuator motor	Out	See pin 18		18 — 35	19

Diagnostic trouble codes TCS

Engine running or ignition in ON position

Diagnostic trouble code	Faulty function/component	TCS-OFF	Text on ISAT display	Action, see page
B1192	TCS switch, shorting to ground	ON	FAULT XX P/I B1192 TCS SWITCH SHORTING TO GROUND	45 (18)
B1302	Position sensor TCS butterfly, shorting to ground/interruption	ON	FAULT XX P/I B1302 TSC THROTTLE SENSOR SHORT TO GR/BREAK	39 (19)
B1303	Position sensor TCS butterfly, short circuit to B+/break	ON	FAULT XX P/I B1303 TCS THROTTLE SENSOR SHORT BATT+/BREAK	39 (19)
B1371	Wheel speed FL, no signal	ON	FAULT XX P/I B1371 WHEEL SPEED FL FAULTY SIG/NO SIG	42 (22)
B1376	Wheel speed FR, no signal	ON	FAULT XX P/I B1376 WHEEL SPEED FR FAULTY SIG/NO SIG	42 (22)
B1381	Wheel speed RL, no signal	ON	FAULT XX P/I B1381 WHEEL SPEED RL FAULTY SIG/NO SIG	42 (22)
B1386	Wheel speed RR, no signal	ON	FAULT XX P/I B1386 WHEEL SPEED RR FAULTY SIG/NO SIG	42 (22)
B1406	Position signal, main throttle butterfly, faulty	ON	FAULT XX P/I B1406 MAIN THROTTLE POS SIGNAL INCORRECT	46 (21)
B1407	Position signal, main throttle butterfly, short circuit to ground	ON	FAULT XX P/I B1407 MAIN THROTTLE POS SHORT TO GROUND	46 (21)
B1408	Position signal, main throttle butterfly, short circuit to battery+/break	ON	FAULT XX P/I B1408 MAIN THROTTLE POS SHORT TO BATT+/BREAK	46 (21)
B1605	TCS control module, control module fault	ON	FAULT XX P/I B1605 CONTROL MODULE INTERNAL FAULT	38 (12)
B1610	Control module not programmed	ON	FAULT XX P/I B1610 CONTROL MODULE NOT PROGRAMMED	50 (35)
B1710	Engine speed, no signal	ON	FAULT XX P/I B1710 ENGINE RPM SIGNAL FAULTY SIG/NO SIG	41 (23)
B2433	TCS throttle body, short-circuit to battery+ or ground	ON	FAULT XX P/I B2433 THROTTLE MOTOR SHORT BATT+/GROUND	47 (19)
B2434	TCS throttle body, break/mechanical fault	ON	FAULT XX P/I B2434 THROTTLE BODY/MOTOR BREAK/MECH FAULT	48 (19)

Fault diagnosis of functions without diagnostic trouble codes

Checking voltage supply, page 54

Checking grounding points, page 54

Disengaging cruise control, page 51

Disengaging MOTRONIC system full-load enrichment, page 52

TCS OFF warning lamp, page 53

TCS function lamp, page 53

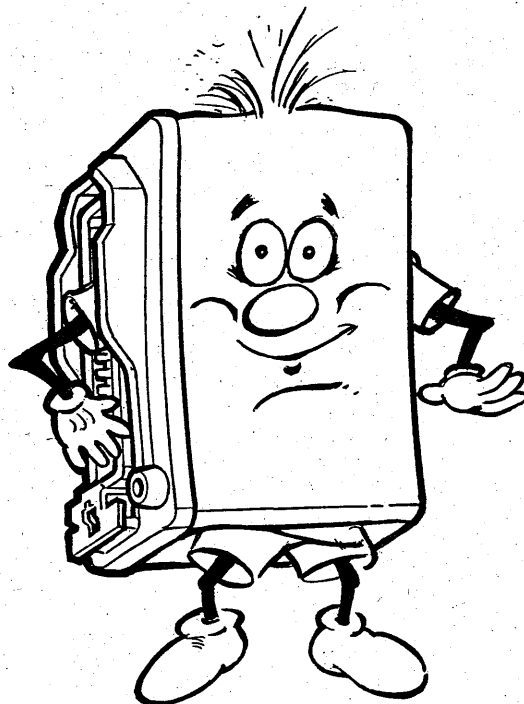

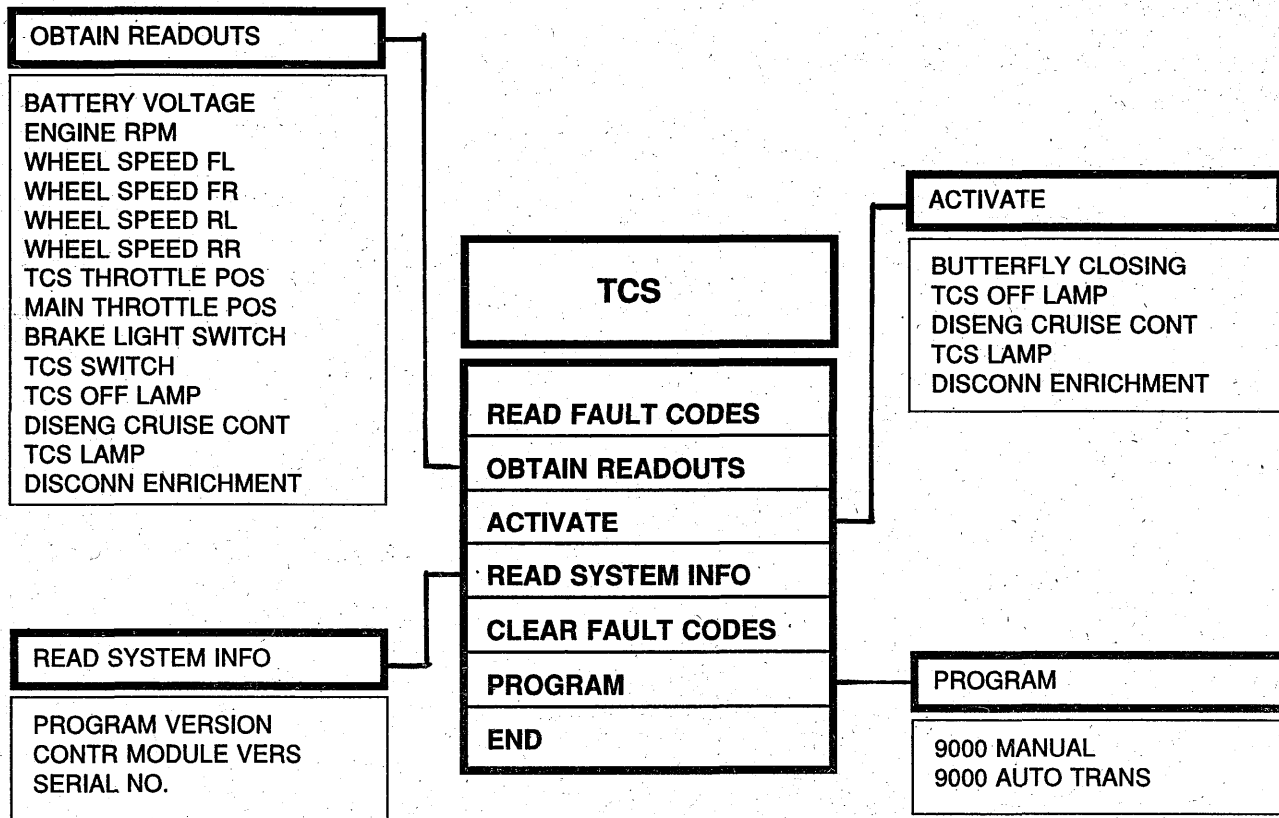

Command menu "OBTAIN READOUTS"

	ISAT display	Function
1	BATTERY VOLTAGE XX.X V	Shows control module supply voltage
2	ENGINE RPM XXXX rpm	Engine speed (shows 450 rpm as lowest value)
3	WHEEL SPEED FL XXX km/h	Wheel speed FL (shows 3 km/h as lowest speed)
4	WHEEL SPEED FR XXX km/h	Wheel speed FR (shows 3 km/h as lowest speed)
5	WHEEL SPEED RL km/h	Wheel speed RL (shows 3 km/h as lowest speed)
6	WHEEL SPEED RR XXX km/h	Wheel speed RR (shows 3 km/h as lowest speed)
7	TCS THROTTLE POS XX %	This figure is the pulse ratio of the TCS throttle position signal from the TCS control module (9-92%)
8	MAIN THROTTLE POS XX %	This figure is the pulse ratio of the main throttle position signal from the MOTRONIC control module to the TCS control module (9-92%)
9	BRAKE LIGHT SWITCH ON/OFF	Shows status of brake light switch
10	TCS SWITCH ACTIVE/NOT ACTIVE	Shows status of TCS switch ("ACTIVE" only when the switch is pressed continuously)
11	TCS OFF LAMP ON/OUT	Shows whether the TCS control module turns on the TCS OFF lamp
12	DISENG CRUISE CONT ON/OFF	Shows whether the TCS control module disengages the cruise control system
13	TCS LAMP ON/OUT	Shows whether the TCS control module turns on the TCS lamp and whether the TCS control module activates the TCS function in the TCM control module
14	DISCONN ENRICHMENT ON/OFF	Shows whether the TCS control module sends the "disconnect full-load enrichment" signal to the MOTRONIC control module (the ISAT display alternates between ON and OFF when the function is activated)

Command menu "ACTIVATE"

	ISAT display	Function
1	THROTTLE CLOSING ON/OFF	The TCS control module closes the TCS throttle almost completely
2	TCS OFF LAMP FUNCTION ON/OFF	The TCS control module activates the TCS OFF lamp
3	DISENG CRUISE CON- TROL FUNCTION ON/OFF	The TCS control module disengages the cruise control system
4	TCS—LAMP FUNCTION ON/OFF	The TCS control module activates the TCS lamp and the TCS program in the TCM control module
5	DISCONN ENRICHMENT FUNCTION ON/OFF	The TCS control module sends battery+ via the lead to the MOTRONIC control module for disconnection of full-load enrichment. The MOTRONIC control module interprets this as fuel shut-off and the engine stops (used only as a wiring check).

Command menus "READ SYSTEM INFO" and "PROGRAM"

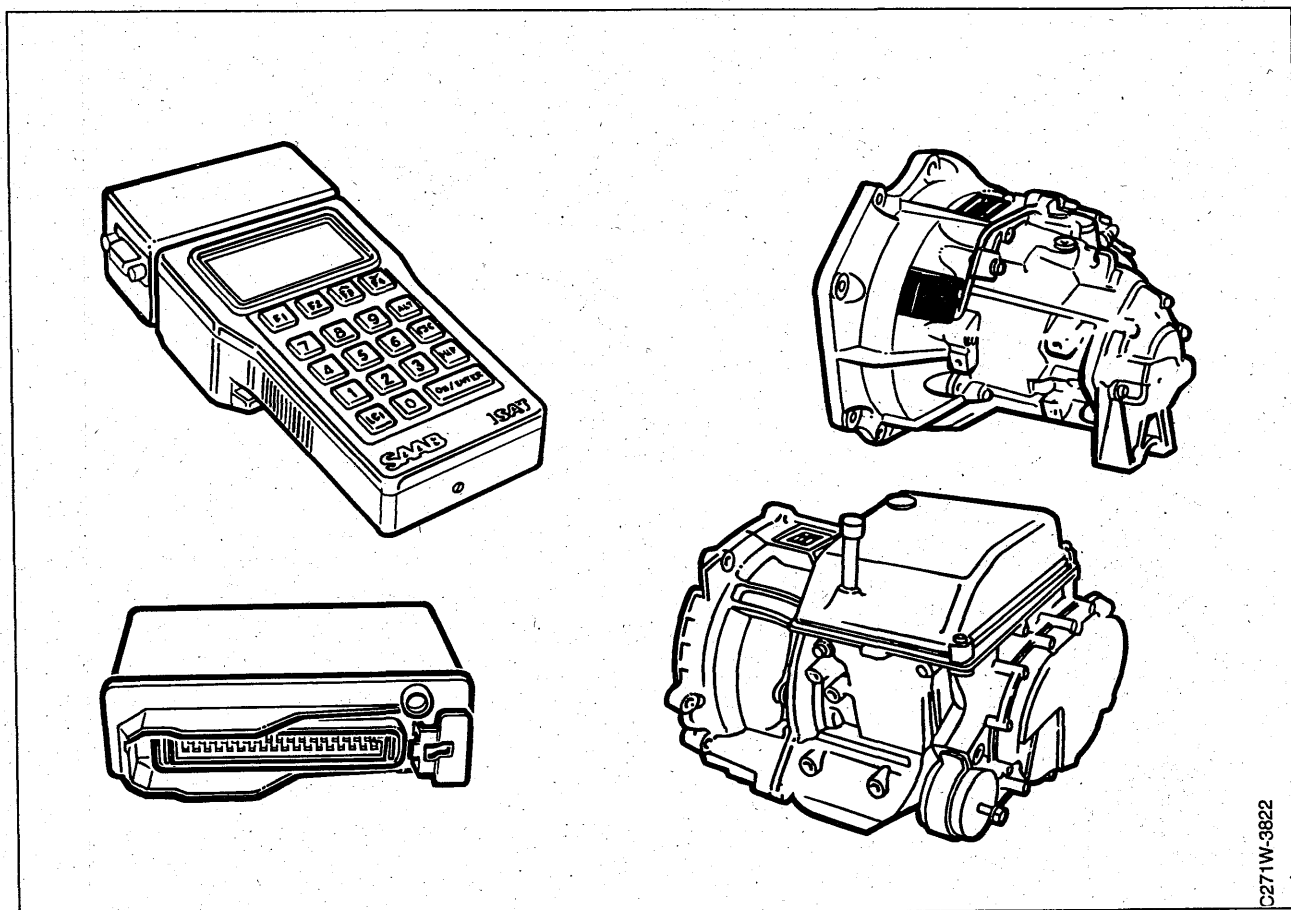

READ SYSTEM INFO

ISAT display	Function
1 PROGRAM VERSION	Shows current program in the TCS control module
2 CONTR MODULE VERS	Shows the control module version number
3 SERIAL NO.	Shows the serial number of the control module

PROGRAM

ISAT display	Function
1 PROGRAMMED FOR 900 MANUAL 900 AUTO TRANS 9000 MANUAL 9000 AUTO TRANS CHANGE/OK	Shows the gearbox variant for which the TCS control module is programmed
2 TYPE OF GEARBOX 9000 MANUAL 9000 AUTO TRANS	Enables the control module to be programmed for the type of gearbox concerned

Fault diagnosis schedule TCS

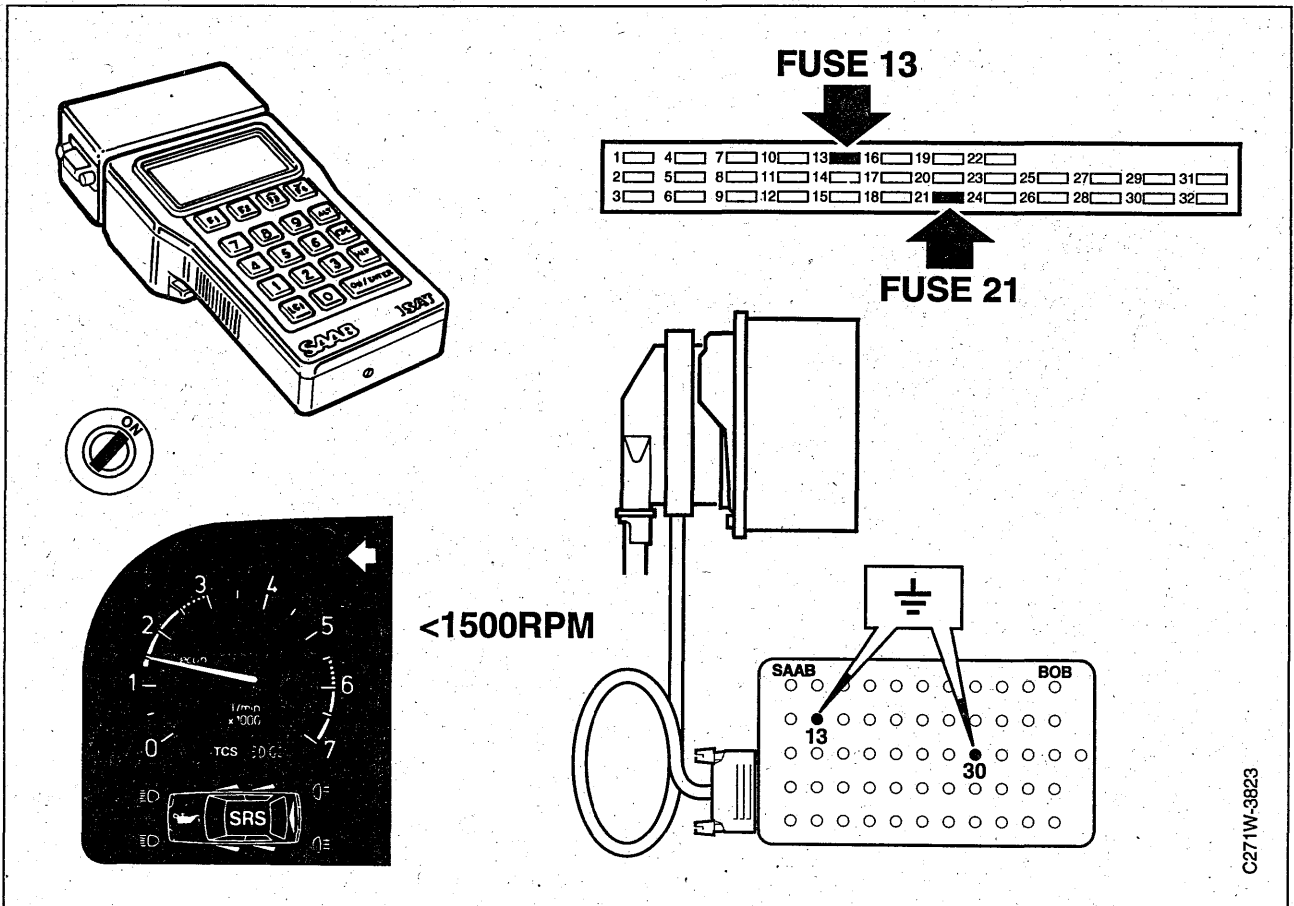

To remember when diagnosing faults

It is not possible to give any general rules for fault diagnosis in each individual case. Depending on the symptom of the fault and other information available, one method might be best in a certain situation, only to be less suited to another situation.

The following points are however intended as a guide for fault diagnosis on the TCS system and it is a good idea to now and then during fault diagnosis work look through the contents of the information on this page.

- 1 Always begin fault diagnosis by reading any diagnostic trouble codes using the ISAT.

Certain diagnostic procedures entail unplugging connectors with the ignition on or moving the TCS throttle butterfly from its normal position. This causes diagnostic trouble codes. For this reason, any diagnostic trouble codes must be erased after work is completed.

- 2 Check fuses 13 and 21.
- 3 Check connectors, especially H70-1 for oxidized contact pins, gaps or anything else that might impair the connection.

If you suspect contact problems, use KONTAKT 61 contact spray (part no. 45-300 45 20) on the female contacts in the connectors.

- 4 When connecting the BOB, first check the voltage supply to pins 28 and 32 and that pins 13 and 30 are fully grounded.

Fault diagnosis schedule TCS (contd.)

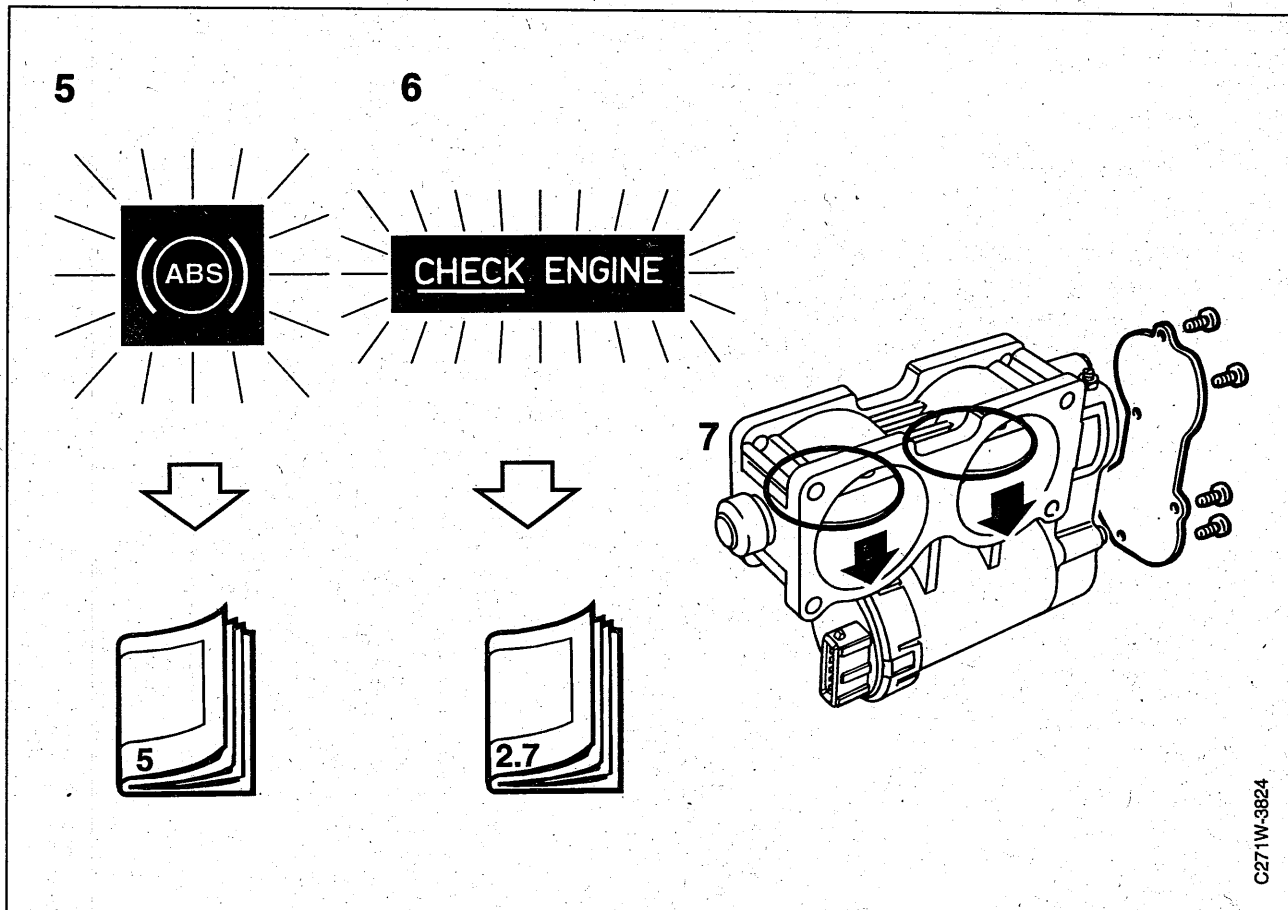

C271W-3824

- 5 If the ANTI LOCK lamp is lit, always begin fault diagnosis in the ABS system.
- 6 If the CHECK ENGINE lamp is lit, always begin fault diagnosis in the MOTRONIC.
- 7 With the ignition switched off, check that the throttle butterfly can freely be moved to the closed position and that it is easily returned to the open position with spring force.

Important

In order to establish communication between the ISAT and the TCS control module, the following must be observed:

- the ignition must be in the drive position
- engine speed must be <1500 rpm (if the engine is running)
- the TCS system must be connected

The ISAT cannot make contact with the system if:

- the circuit to pin 9 on the control module is faulty
- pins 13/30 are not correctly grounded
- pins 28/32 do not have the correct voltage supply
- the circuit to pin 3 is shorted to battery+

Diagnostic trouble code B1605

Control module fault

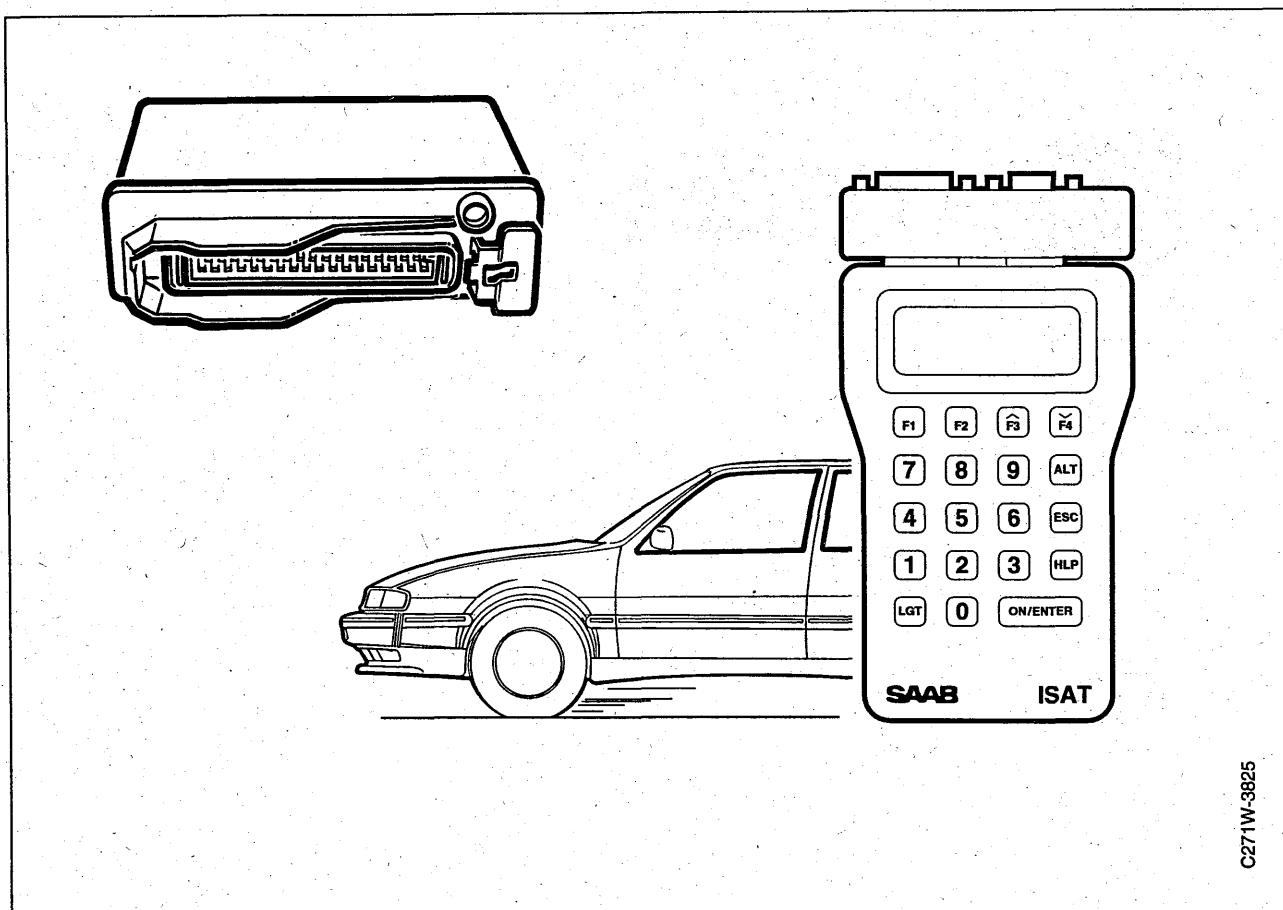

C271W-3825

Fault symptom

TCS OFF lamp lit, TCS system not functioning

Conditions

Internal fault in the control module.

Action

- 1 Erase the diagnostic trouble code. Start and test-drive the car and see if the diagnostic trouble code is re-registered. If it is, proceed to page 55 for further action.

Diagnostic trouble codes B1302, B1303

TCS throttle butterfly position sensor, break/short-circuit

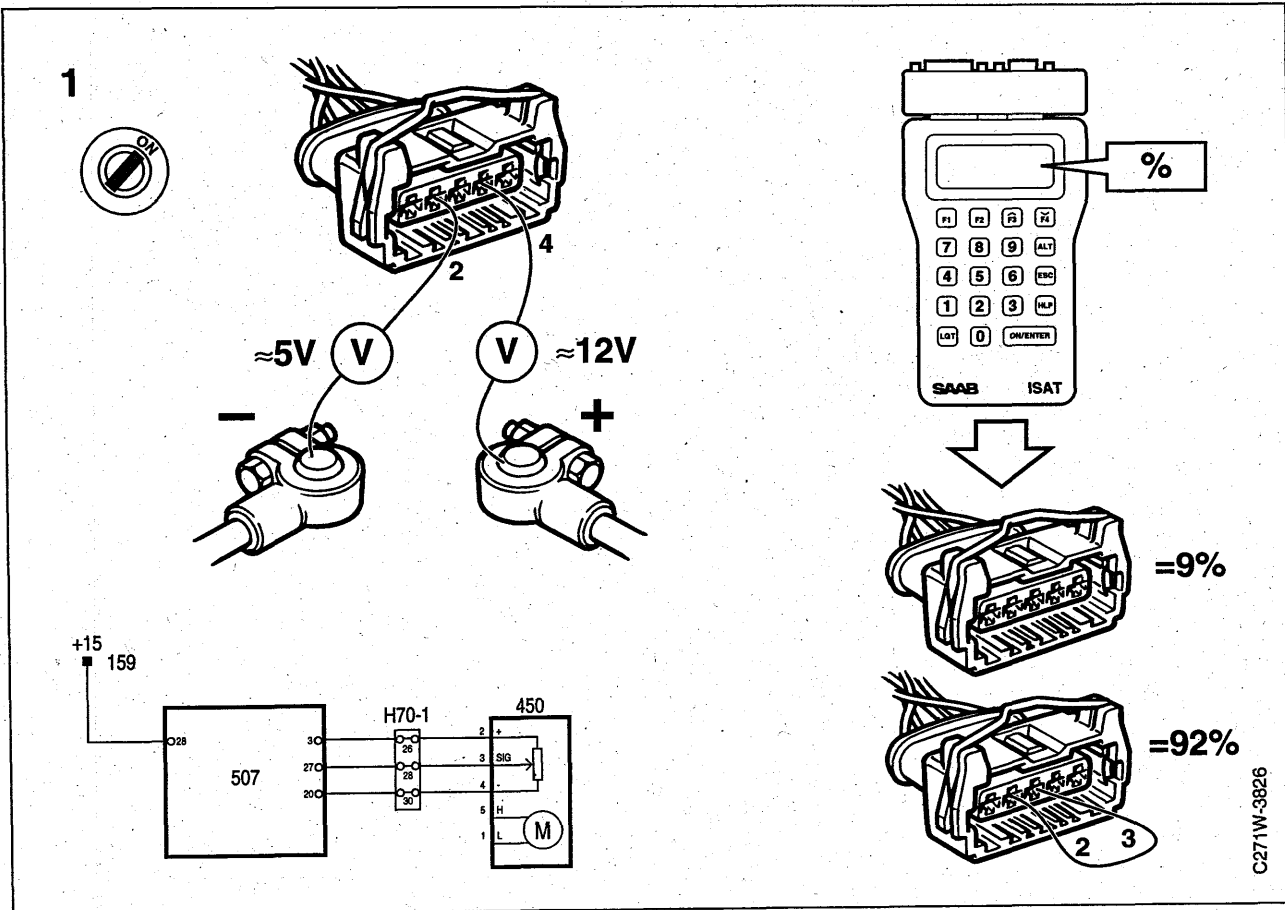

Fault symptom

TCS OFF lamp lit, TCS system not functioning

Conditions

For diagnostic trouble code B1302: Control module output pin 3 broken or shorted to ground, or control module input pin 27 shorted to ground

For diagnostic trouble code B1303: Control module output pin 20 broken or shorted to battery+, or control module input pin 27 shorted to battery+.

Important

B1302 and B1303 can be registered during fault diagnosis when connectors to the throttle body and unplugged and the ignition is placed in the drive position.

Action

Check the cable assembly to the control module:

- 1 Unplug the 5 pin connector from the throttle body.
Ignition in ON position.

Measure voltage supply in the female connector:

- pin 2 to Batt- _____ approx. 5V
- Batt+ to pin 4 _____ approx 12V

Connect the ISAT and select the command "TCS THROTTLE POS" in the "OBTAIN READOUTS" menu.

- ISAT should show approx 9%

Bridge between pins 2 and 3 in the female connector.

- ISAT should now show approx 92%.

If all measured values are correct, change the throttle body.

If any of the values is incorrect, proceed to point 2.

Diagnostic trouble codes B1302, B1303 (contd.)

TCS throttle butterfly position sensor, break/short-circuit

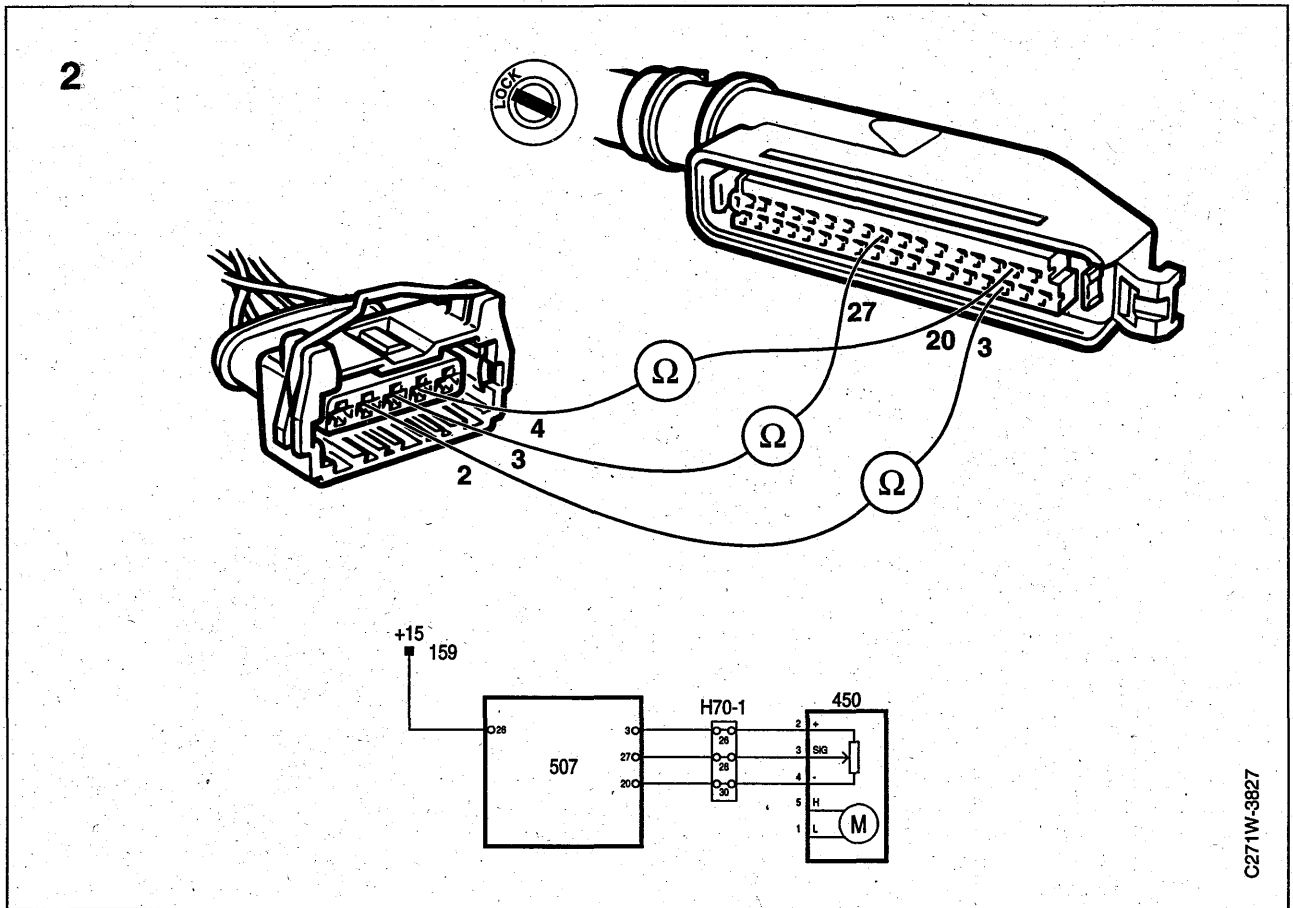

2 Conduct continuity tests on the leads between pins 2,3,4 in the female connector and associated control module connector for breaks, shorts and any bypasses.

If the values are correct, proceed to point 3.

3 Erase the diagnostic trouble code, test-drive the car and see if the diagnostic trouble code is re-registered.

If the trouble code is registered, proceed to page 55.

If the diagnostic trouble code is not registered, the action taken was correct or the fault was of the intermittent type.

Diagnostic trouble code B1710

No engine speed signal

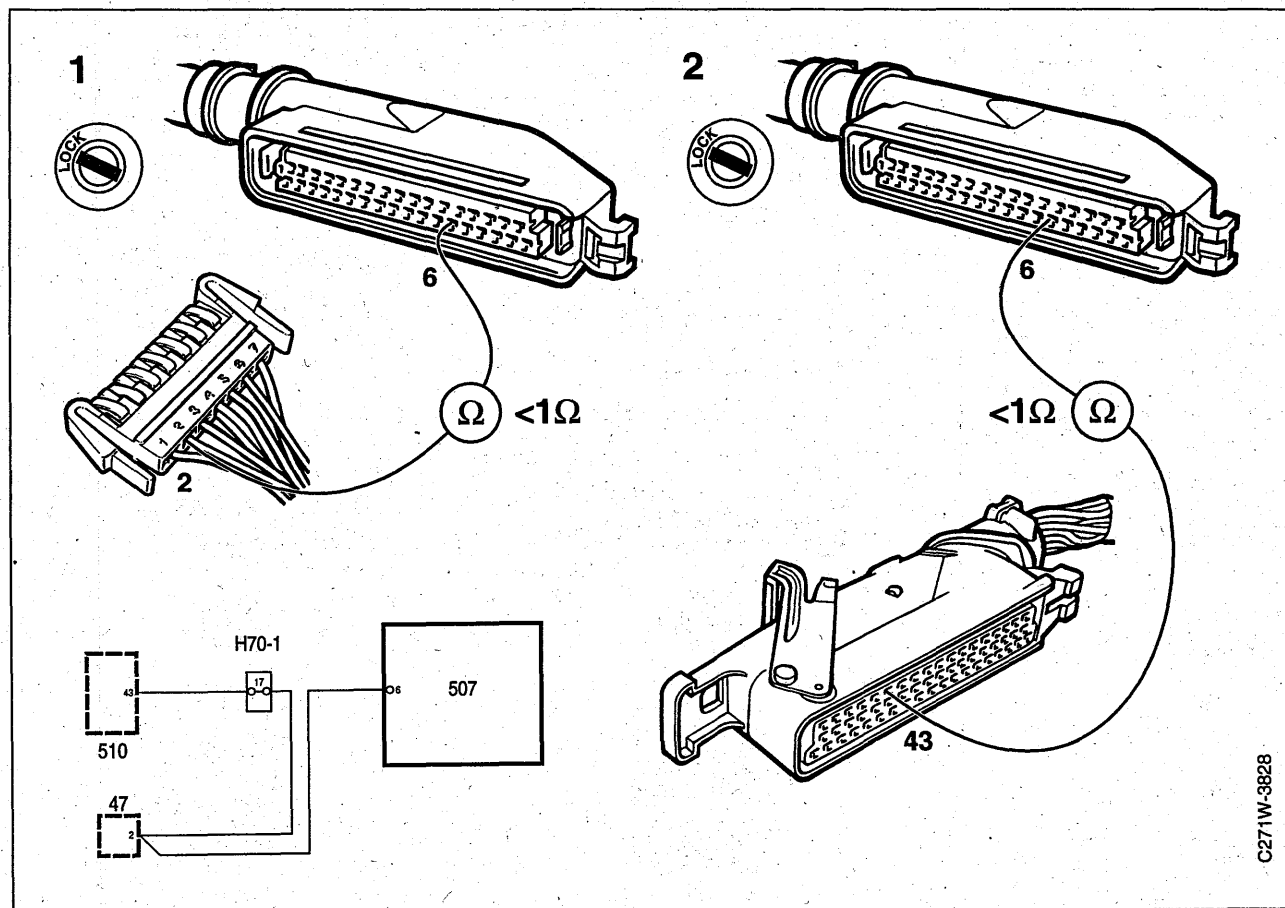

Fault symptom

TCS OFF lamp lit, TCS system not functioning

Conditions

No engine speed signal and the car is travelling at over 60 km/h.

Action

Check the lead between the MOTRONIC control module and the TCS control module:

- 1 If the tachometer is working, conduct continuity test on the lead between speedometer pin 2 and TCS control module pin 6 for breaks.
- 2 If the tachometer is not working, conduct a continuity test between pin 43 on the MOTRONIC control module via pin 2 on the speedometer to pin 6 on the TCS control module for breaks, shorts and bypasses.
- 3 Erase the diagnostic trouble code, test-drive the car and see if the diagnostic trouble code is re-registered.
If the trouble code is registered, proceed to page 55.
If the diagnostic trouble code is not registered, the action taken was correct or the fault was of the intermittent type.

Diagnostic trouble codes B1371 Wheel speed FL, faulty or no signal
 B1376 Wheel speed FR, faulty or no signal
 B1381 Wheel speed RL, faulty or no signal
 B1386 Wheel speed RR, faulty or no signal

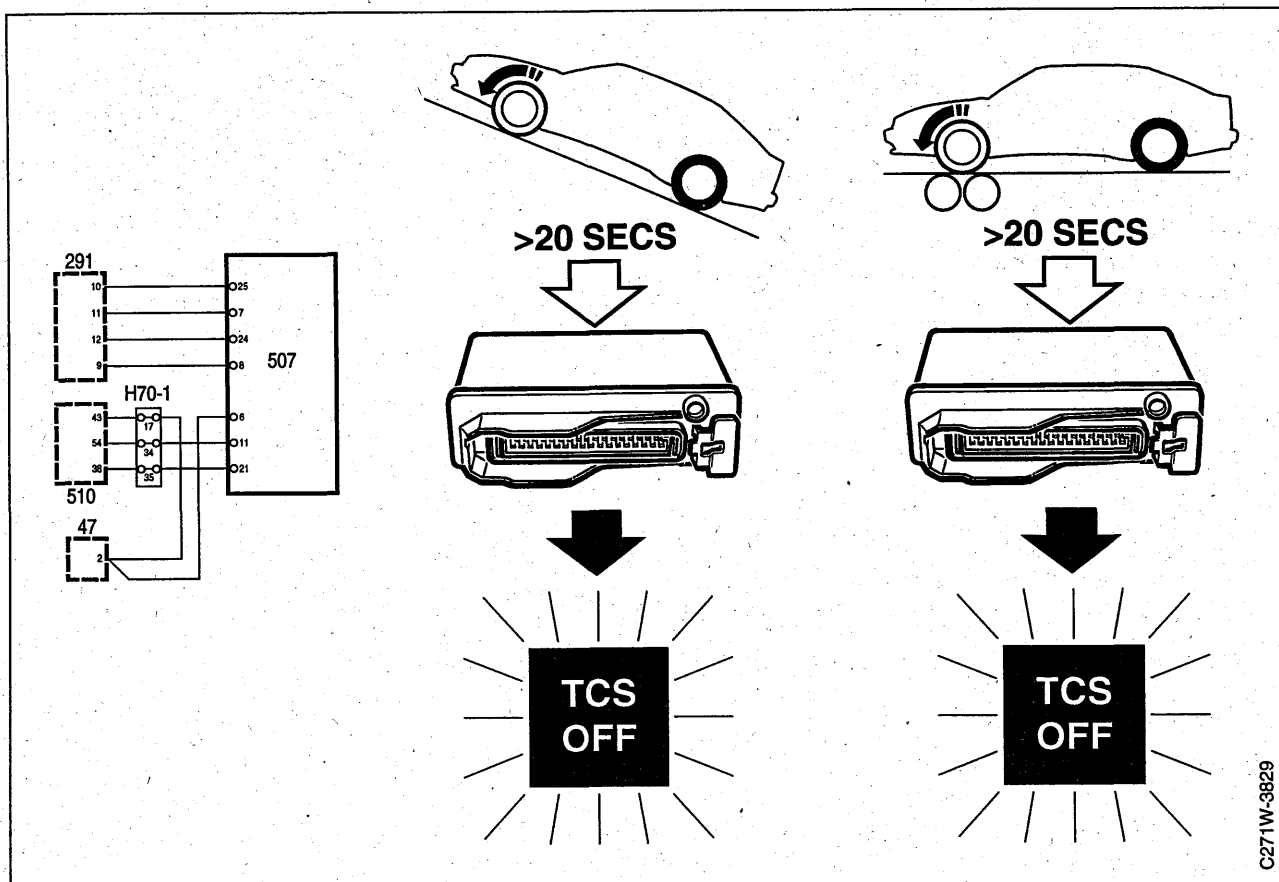

Fault symptom

TCS OFF lamp lit, TCS system not functioning.

Conditions

Wheel speed signal incorrect or absent, or indicates a speed higher than 280 km/h

Important

The diagnostic trouble code for wheel signals can be generated when the brakes are tested or if the car is started on a slippery uphill gradient, when the front wheels spin and the rear wheels remain stationary.

If only one wheel spins and the other three remain stationary, the control module cannot tell whether the speed signals from the three stationary wheels are correct or false. In this case, trouble codes are generated for the three stationary wheels. The trouble codes are however automatically erased as soon as the signals return.

If wheelspin continues for more than 20 seconds, while one of the wheels remains stationary, The TCS system is disconnected and the TCS OFF lamp lights. To restore the TCS function, the ignition must be switched off and back on again.

C271W-3629

Diagnostic trouble codes B1371 Wheel speed FL, faulty or no signal (contd.)
B1376 Wheel speed FL, faulty or no signal (contd.)
B1381 Wheel speed RL, faulty or no signal (contd.)
B1386 Wheel speed RR, faulty or no signal (contd.)

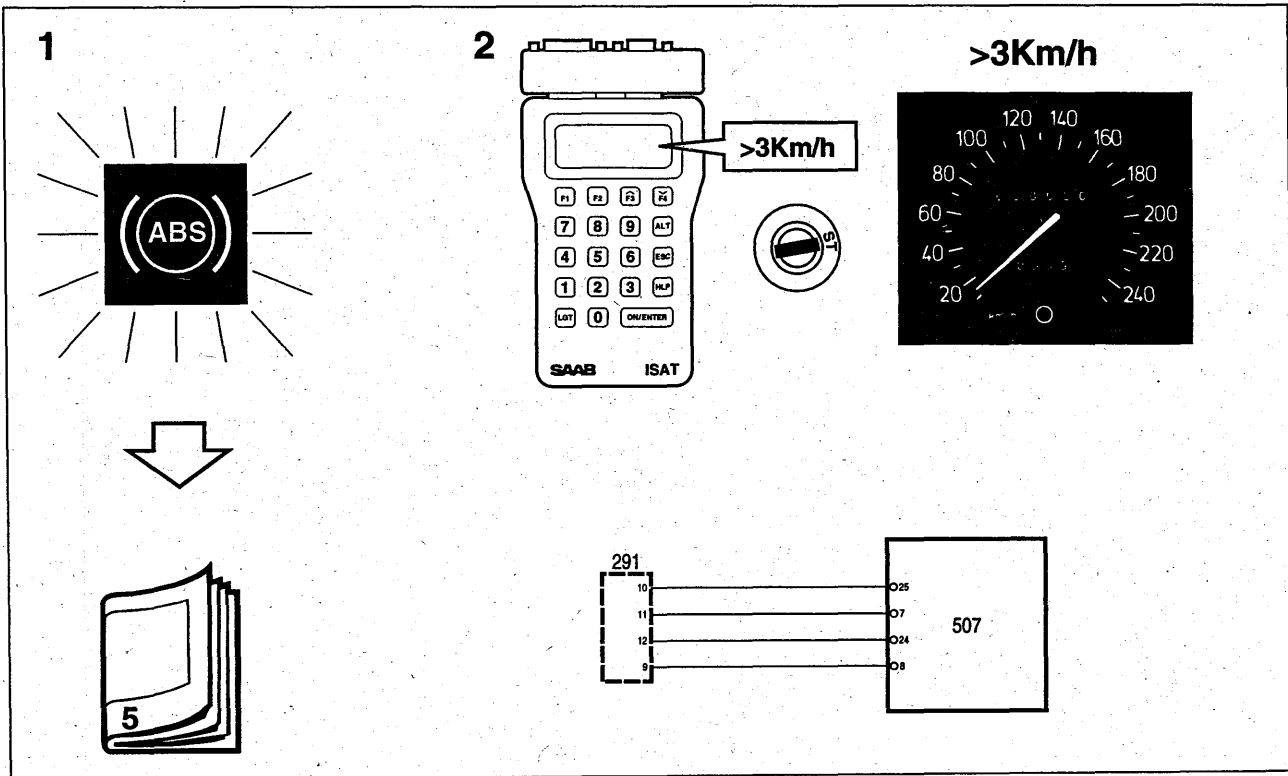

Action

1 If the ANTI LOCK lamp also lights while driving, obtain readings and act on diagnostic trouble codes in the ABS system, see Service Manual 5, Brakes.

Ensure that there is no wheel speed signal:

2 Ignition in ON position.

Connect the ISAT and select the "WHEEL SPEED" command in the "OBTAIN READ-OUTS" menu.

Check by driving the car or by rotating each wheel that all four wheel speed signals are functioning.

Note that the lowest display on the ISAT is 3km/h

If all values are correct, proceed to point 4.

If any value is incorrect, proceed to point 3.

Diagnostic trouble codes **B1371** Wheel speed FL, faulty or no signal (contd.)
B1376 Wheel speed FL, faulty or no signal (contd.)
B1381 Wheel speed RL, faulty or no signal (contd.)
B1386 Wheel speed RR, faulty or no signal (contd.)

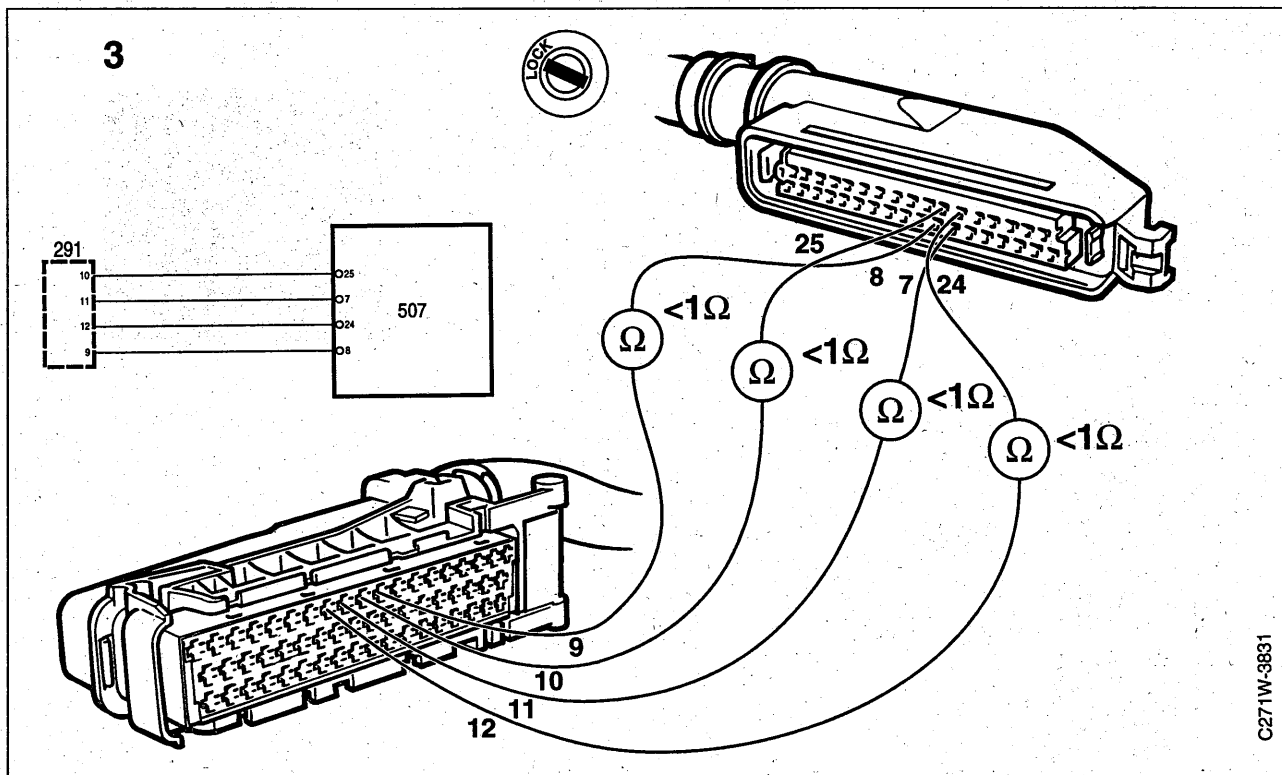

3 Conduct continuity measurements on the lead for the wheel speed signal in question. Check between the ABS control module and the TCS control module for breaks, shorts and bypasses. If the values are correct, proceed to point 4.

Wheel	Pin on ABS control module	Pin on TCS control module
FL	10	25
FR	11	7
RL	12	24
RR	9	8

4 Erase the diagnostic trouble code, test-drive the car and see if the diagnostic trouble code is re-registered. If the trouble code is registered, proceed to page 55. If the diagnostic trouble code is not registered, the action taken was correct or the fault was of the intermittent type.

Diagnostic trouble code B1192

TCS switch shorted to ground

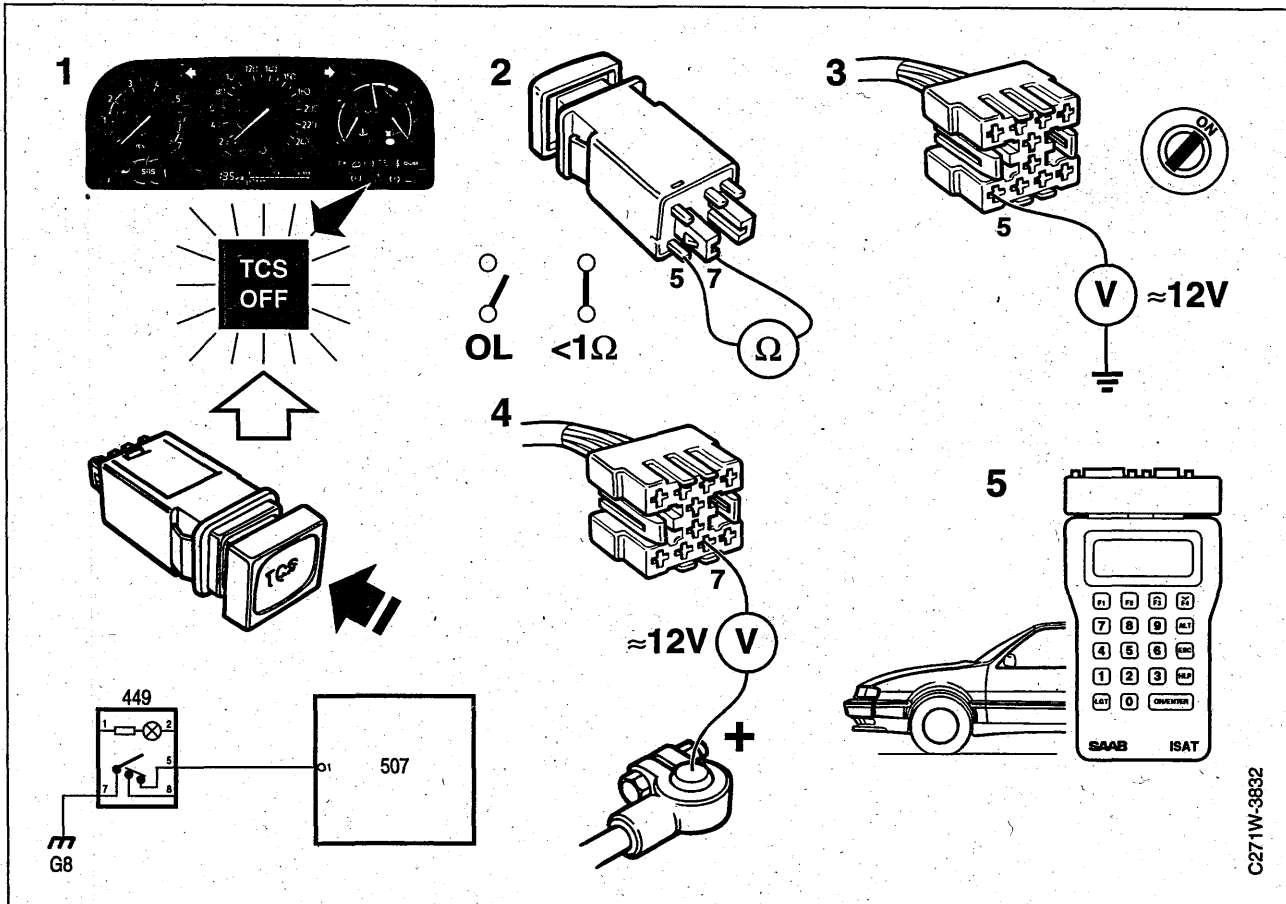

Fault symptom

The TCS system cannot be turned off with the TCS switch

Conditions

Control module input pin 1 shorted to ground for more than 10 seconds, or switch held depressed for more than 10 seconds.

Action

Check the function of the switch.
Ignition in ON position.

- 1 If the TCS switch is pressed repeatedly, the TCS OFF lamp should alternately go on and off.

If this is OK, proceed to point 5.

If the function is faulty, proceed to point 2.

- 2 Remove the TCS switch from the fascia. Unplug the connector from the switch and check that the resistance across pins 5 and 7 of the switch is $<1\ \Omega$ when the switch is depressed and infinite (OL) when the switch is not depressed.

If values are incorrect, change the switch

- 3 With the ignition in the drive position, check that there is Batt+ across pin 5 of the switch contact and a safe grounding point.

If this is not the case, check the lead between pin 5 of the contact and pin 1 of the TCS control module for breaks/short circuit to ground.

- 4 Check that there is Batt+ between pin 7 of the switch contact and B plus.

If this is not the case, check for breaks in the lead between pin 7 on the connector and grounding point G8.

- 5 Erase the diagnostic trouble code, test-drive the car and see if the diagnostic trouble code is re-registered.

If the trouble code is registered, proceed to page 55.

If the diagnostic trouble code is not registered, the action taken was correct or the fault was of the intermittent type.

Diagnostic trouble code B1406, B1407, B1408

Main throttle butterfly position signal, faulty, break/short-circuit

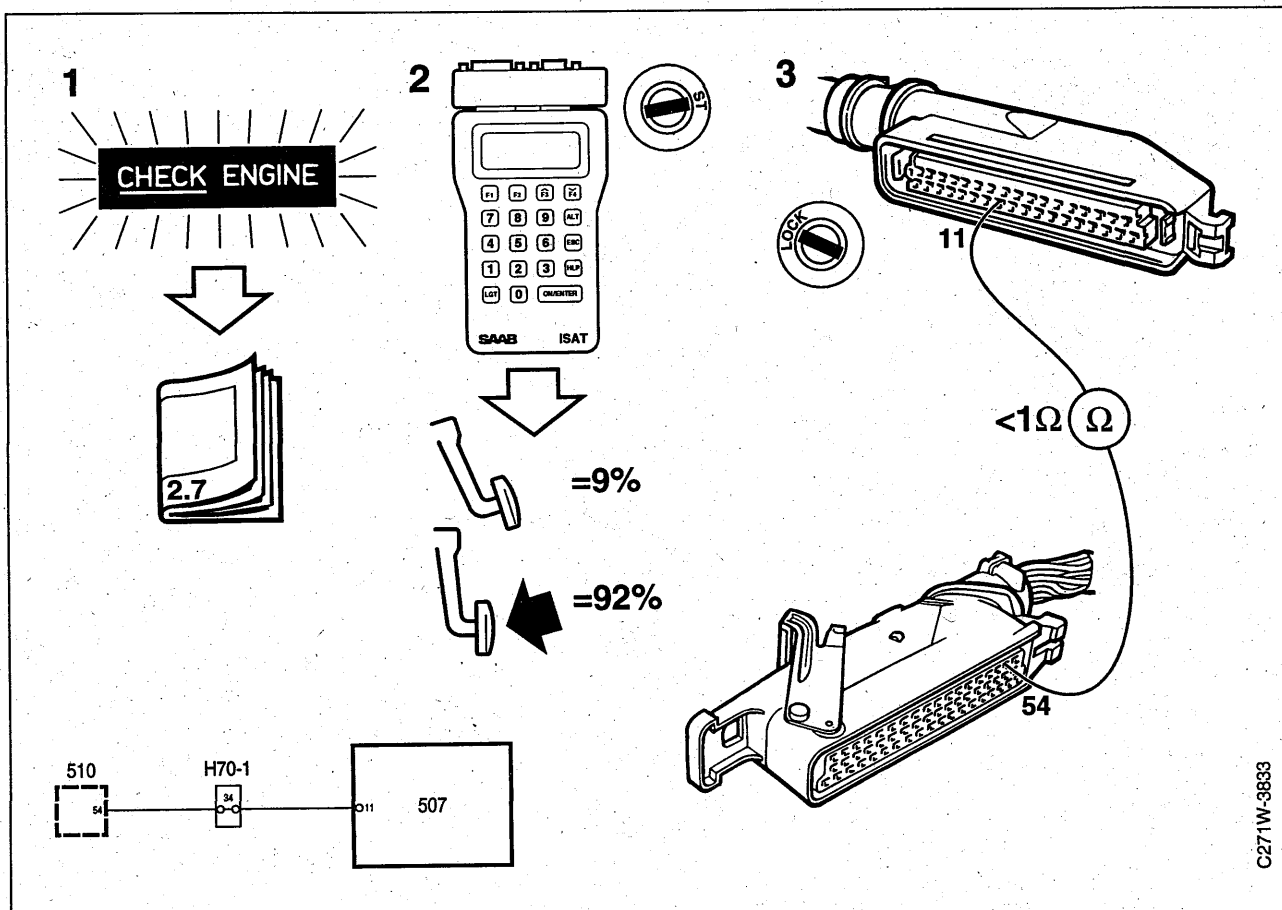

Fault symptom

TCS OFF lamp lit, TCS system not functioning and possibility of diagnostic trouble codes in the MOTRONIC

Conditions

For diagnostic trouble code B1406: Main butterfly position signal from pin 54 in the MOTRONIC control module to pin 11 in the TCS control module is faulty

For diagnostic trouble code B1407: Main butterfly position signal from pin 54 in the MOTRONIC control module to pin 11 in the TCS control module is shorted to ground

For diagnostic trouble code B1408: Main butterfly position signal from pin 54 in the MOTRONIC control module to pin 11 in the TCS control module is shorted to Batt+/-broken

Action

- 1 If the CHECK ENGINE lamp is also lit when driving, read and act on diagnostic trouble codes in the MOTRONIC. See Service Manual 2:7 Motronic 2.8.1.

- 2 Start the engine.

Connect the ISAT and select the "MAIN THROTTLE POS" command in the "OBTAIN READ-OUTS" menu.

- The ISAT should show approx. 9% when idling and approx. 92% at wide open throttle. If the values are correct, proceed to point 4. If the values are incorrect, proceed to point 3.
- 3 Conduct continuity test on the lead between pin 54 of the MOTRONIC control module and pin 11 of the TCS control module for breaks, shorts and bypasses. If the value is correct, proceed to point 4.
 - 4 Erase the diagnostic trouble code, test-drive the car and see if the diagnostic trouble code is re-registered. If the trouble code is registered, proceed to page 55. If the diagnostic trouble code is not registered, the action taken was correct or the fault was of the intermittent type.

Diagnostic trouble code B2433

TCS butterfly actuator motor shorted to ground/Batt+

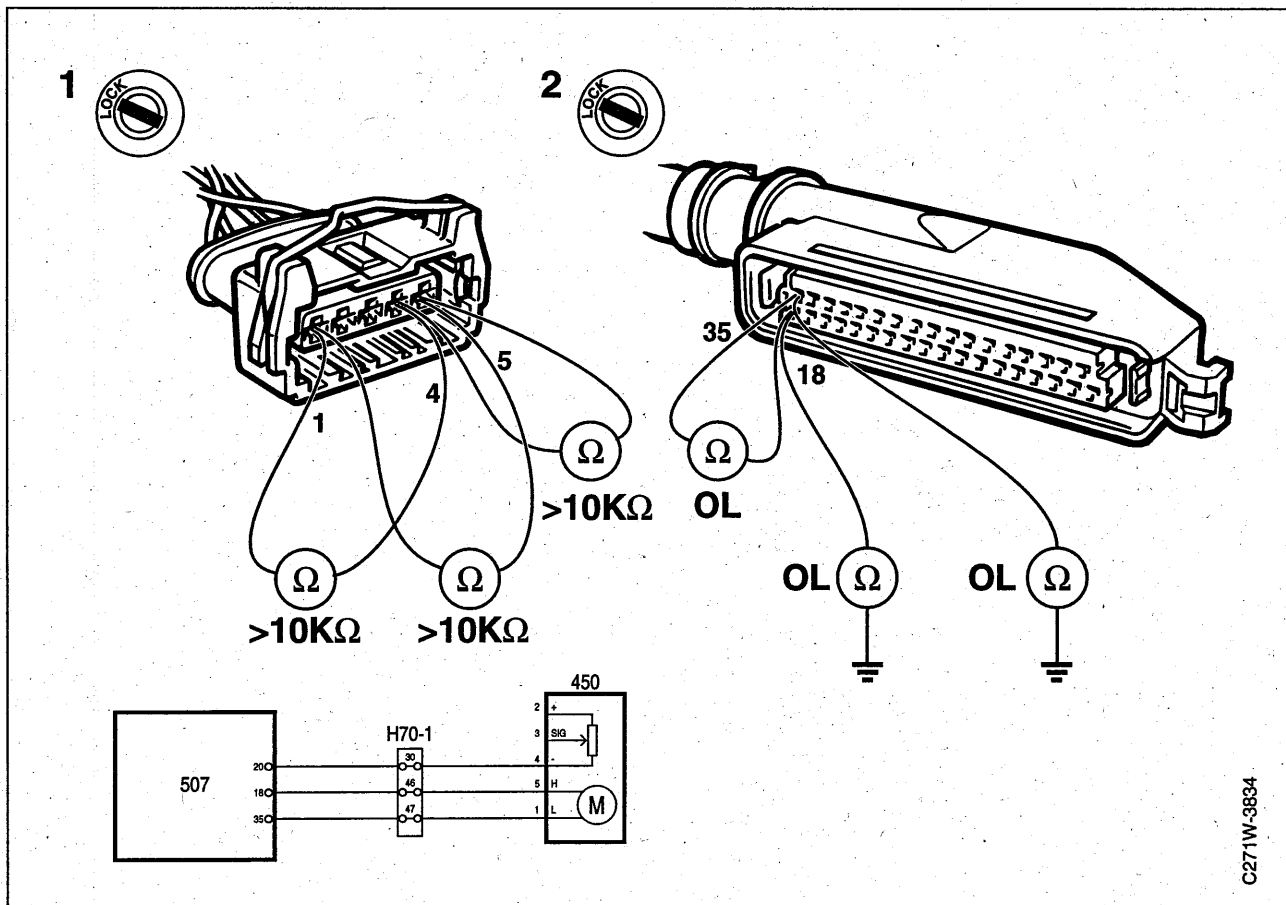

Fault symptom

TCS OFF lamp lit, TCS system not functioning

Conditions

Control module output pin 18 shorted to ground, Batt+ or to pin 35.

Control module output pin 35 shorted to ground, Batt+ or to pin 18.

Action

Check the leads to the throttle actuator motor for shorts:

1 Ignition in OFF position.

Unplug the throttle body connector. Check the resistance in the female connector.

- pin 4 (ground) to pin 1 _____ $>10\text{ k}\Omega$
- pin 4 (ground) to pin 5 _____ $>10\text{ k}\Omega$
- pin 1 to pin 5 _____ $>10\text{ k}\Omega$

If the values are correct, change the throttle body.
If the values are incorrect, proceed to point 2.

2 Unplug the throttle body connector.

Conduct a continuity test on the two leads from control module outputs 18 and 35 for shorting to ground, to Batt+ or between the leads.

If the values are correct, proceed to point 3.

3 Erase the diagnostic trouble code, test-drive the car and see if the diagnostic trouble code is re-registered.

If the trouble code is registered, proceed to page 55.

If the diagnostic trouble code is not registered, the action taken was correct or the fault was of the intermittent type.

Diagnostic trouble code B2434

TCS throttle actuator motor, break or mechanical fault

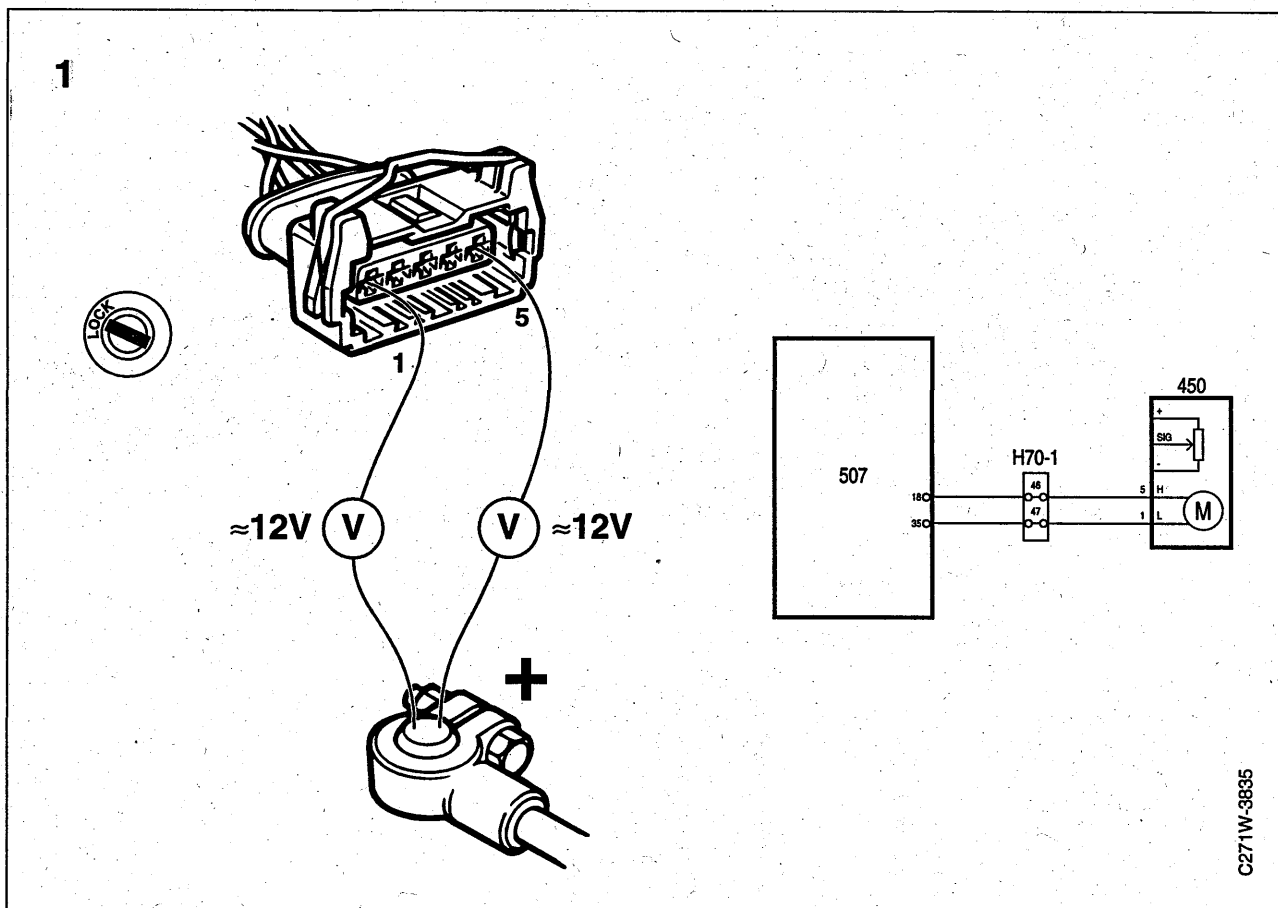

Fault symptom

TCS OFF lamp lit, TCS system not functioning

Conditions

Control module output pin 18, break.
Control module output pin 35, break.
Throttle mechanism or motor seizing.
Linkage or return spring faulty.

Important

B2434 is generated when the throttle's "ACTUAL" value does not coincide with its "REFERENCE" value. This means that the throttle cannot assume a position calculated by the control module. This could be due to one of two reasons.

- Mechanical fault, for example seized butterfly.
- An electrical fault such as a break which prevents the throttle motor from working.
If there is another diagnostic trouble code in the TCS system, remedy that first.

Action

Check the leads to the throttle motor for breaks.

1 Ignition in the OFF position.

Unplug the connector from the throttle body.

Check the voltage supply in the female connector.

- pin 1 to Batt+ _____ approx. 12V
- pin 5 to Batt+ _____ approx. 12V
If the values are correct, proceed to point 2.
If the values are incorrect, proceed to point 3.

Diagnostic trouble codes B2434 (contd.)

TCS throttle motor shorted to ground/Batt+, break or mechanical fault

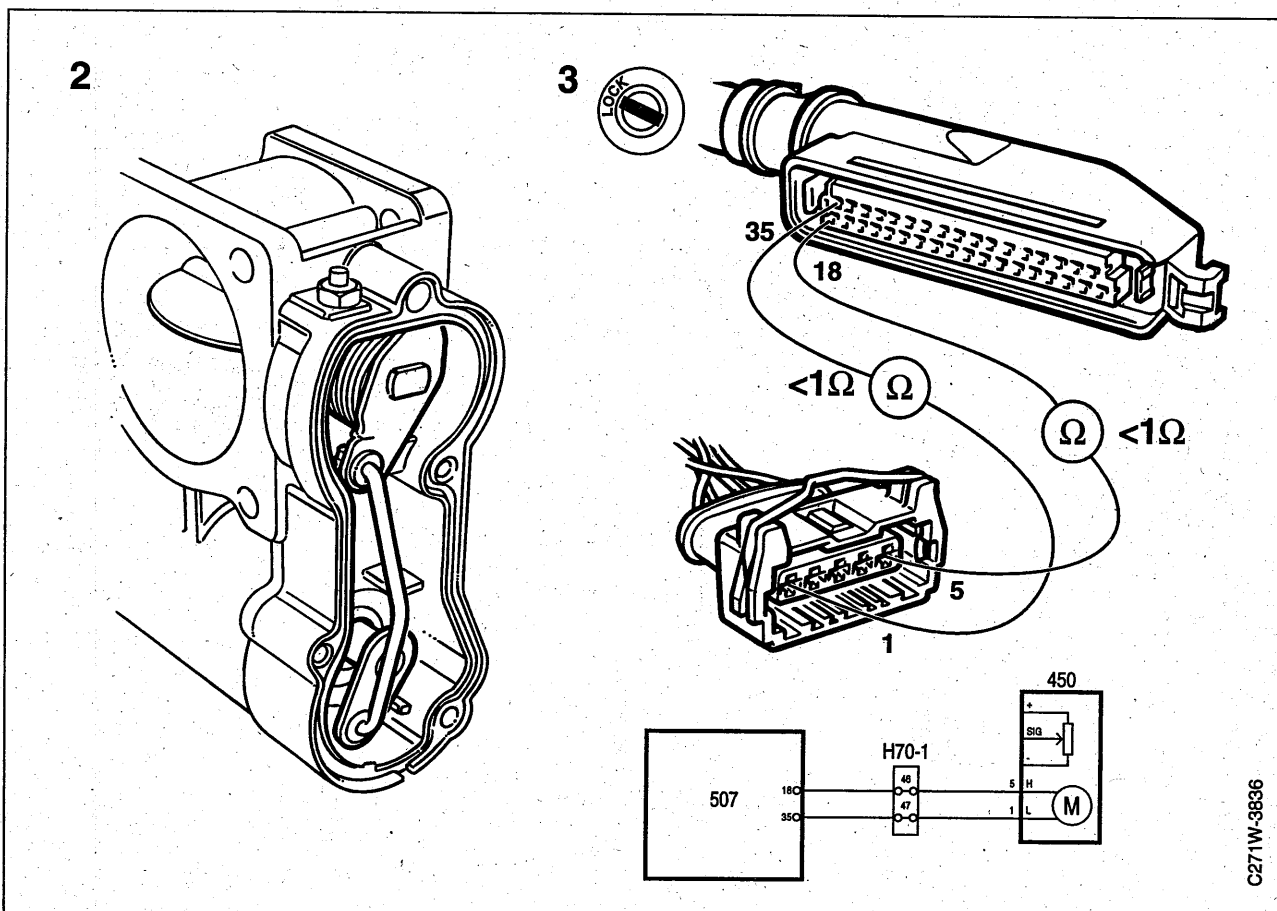

C271W-3836

- 2 Remove the cover from the throttle body linkage. With the ignition turned off, check that the butterfly can easily be closed against the stop screw without siezing. The butterfly should also easily return to the fully open position under spring force. If the function is OK, change the throttle body. If the function is not correct, remedy the fault if possible or change the throttle body.
- 3 Conduct continuity tests on the two leads from control module outputs 18 and 35 for breaks. If the values are correct, proceed to point 4.
- 4 Erase the diagnostic trouble code, test-drive the car and see if the diagnostic trouble code is re-registered. If the trouble code is registered, proceed to page 55. If the diagnostic trouble code is not registered, the action taken was correct or the fault was of the intermittent type.

Diagnostic trouble code B1610

Control module not programmed

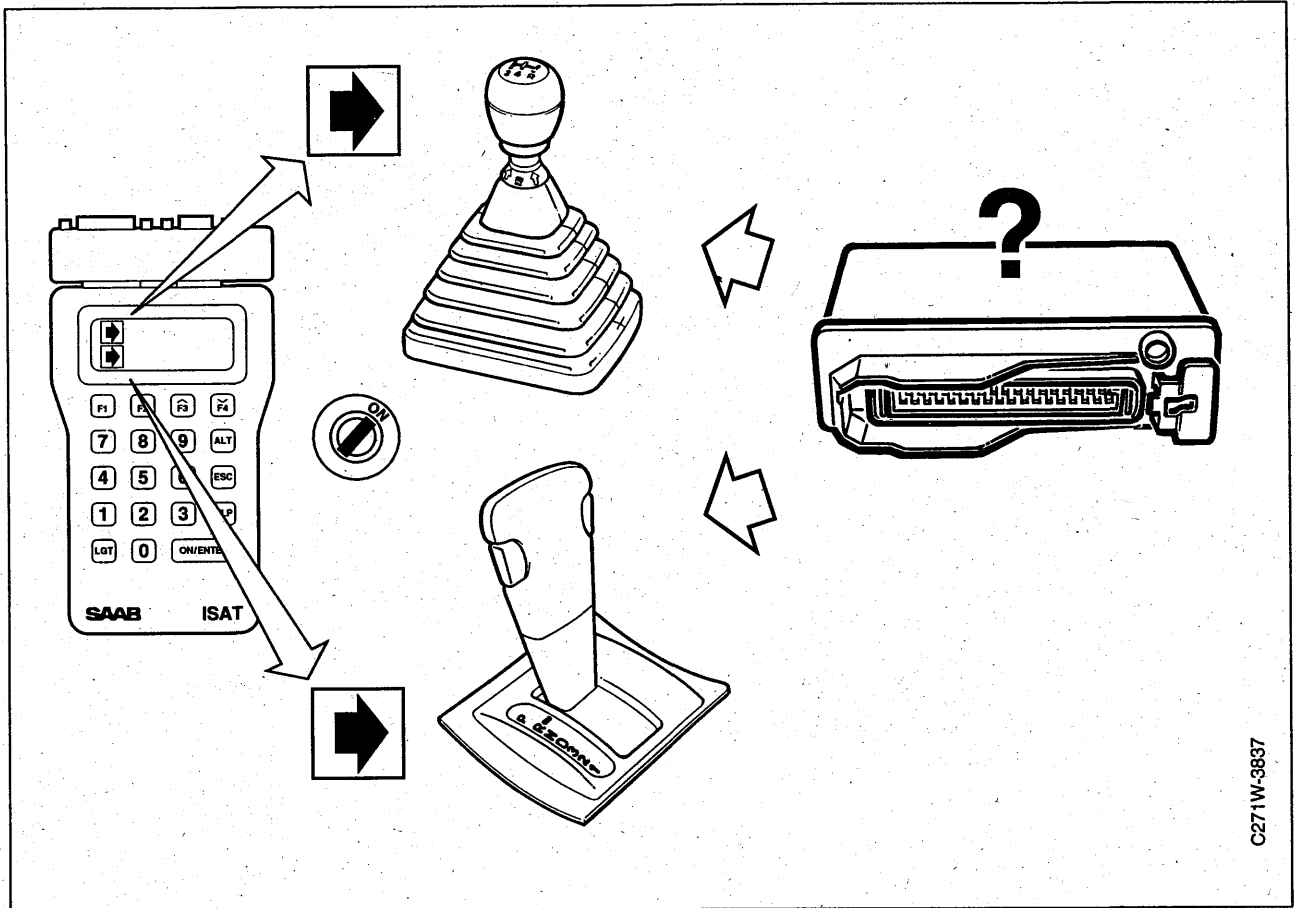

C271W-3837

Fault symptom

TCS OFF lamp lit, TCS system not functioning

Conditions

Control module not programmed

Action

- 1 Program the control module using the ISAT.
 - Select "9000 MANUAL" or "9000 AUTO TRANS".
- 2 Erase diagnostic trouble code.
 - Test-drive the car to see if the diagnostic trouble code is regenerated.
 - If the diagnostic trouble code is not regenerated, the action taken was correct.

Checking cruise control disengagement

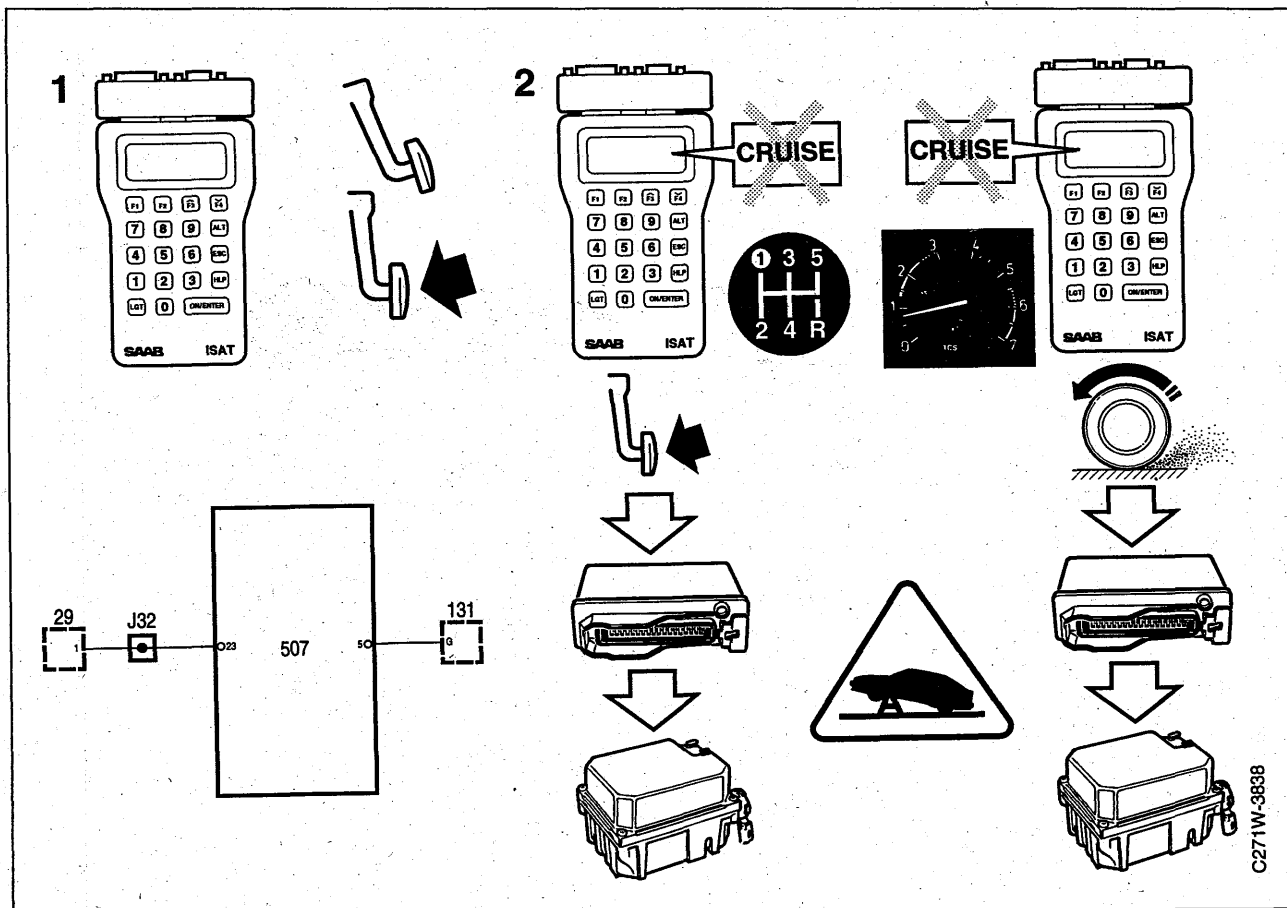

Fault symptom

The cruise control does not disengage when the TCS function is activated

Action

1 Connect the ISAT and select the "BRAKE LIGHT SWITCH" command in the "OBTAIN READOUTS" menu.

Check that the brake light switch is in working order.

If it is, proceed to point 2.

If it is faulty, check the operation of the brake light switch as described in Service Manual 3:2. Also check for breaks in the leads between crimped connector J32 and TCS control module pin 23.

2 Select "DISENG CRUISE CONT" in the "OBTAIN READOUTS" menu and check that the operation is correct when the TCS function is activated or the brakes are applied.

Important

The TCS lamp lights for about 1 second before disengagement.

If this functions correctly, check for breaks and shorts in the lead from TCS control module pin 5 to cruise control pin G.

If the function is faulty, proceed to page 55.

WARNING

The car can be jacked up to activate the TCS function. If this method is used, proceed with extreme care. If only the front of the car is raised and supported on stands, the hand-brake must always be applied and personnel should never stand in front of the car or beside the front wheels while the test is in progress. Speed should be restricted to the minimum possible above 4 km/h.

Checking disconnection of full-load enrichment

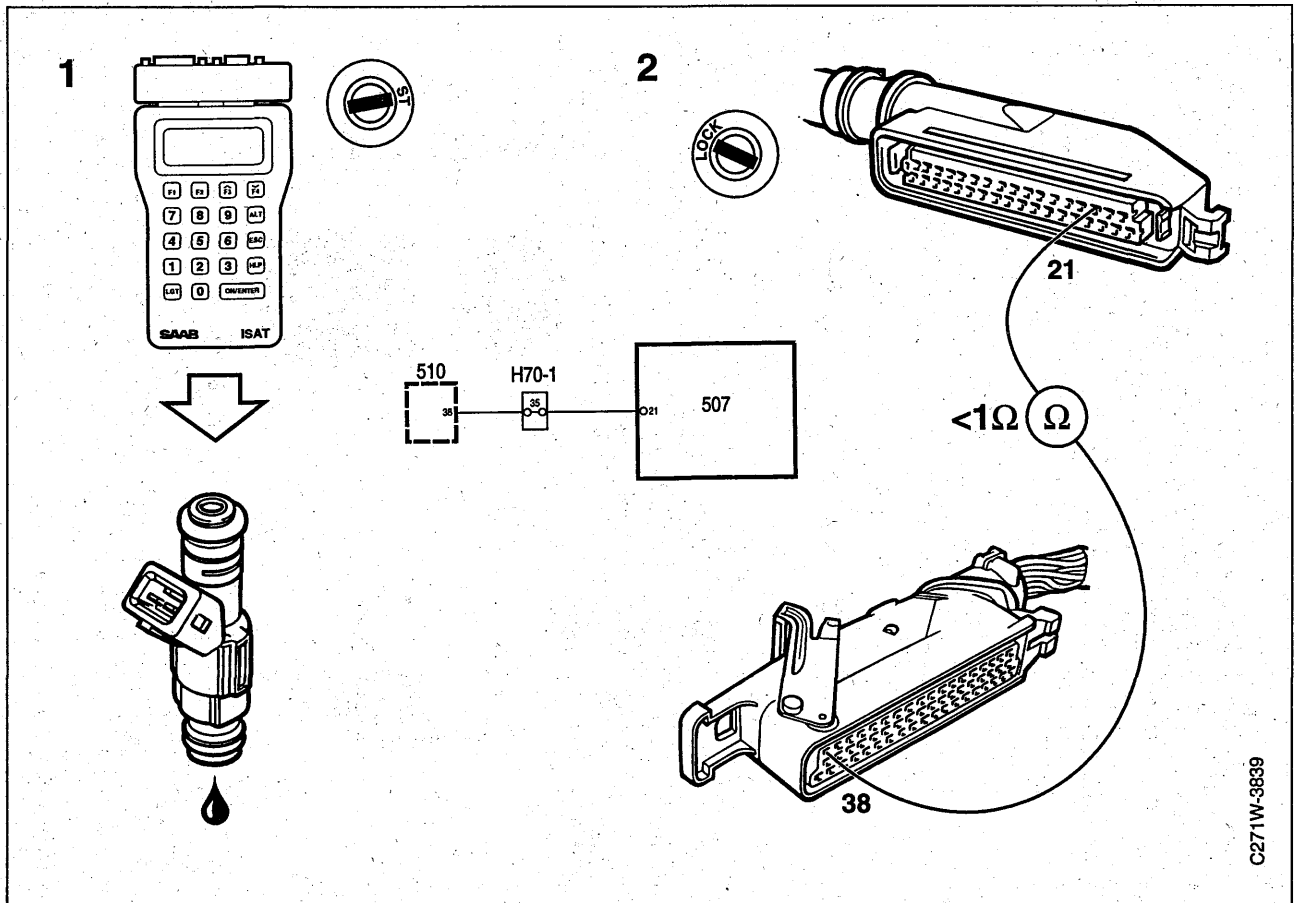

Fault symptom

Diagnostic trouble codes generated in the MOTRONIC (P1630, P1631).

Action

- 1 Start the engine and let it idle.
Connect the ISAT and select "DISCONN ENRICHMENT" in the "ACTIVATE" menu.
When the ISAT function is activated, the engine should stop.
If this works OK, the diagnostic trouble code (if any) in the MOTRONIC can be left without action.
If the function is faulty, proceed to point 2.
- 2 Conduct continuity test on the lead between TCS control module pin 21 and MOTRONIC connector pin 38, looking for breaks or shorts.
If the values are correct, proceed to page 55.

Checking TCS and TCS OFF lamps

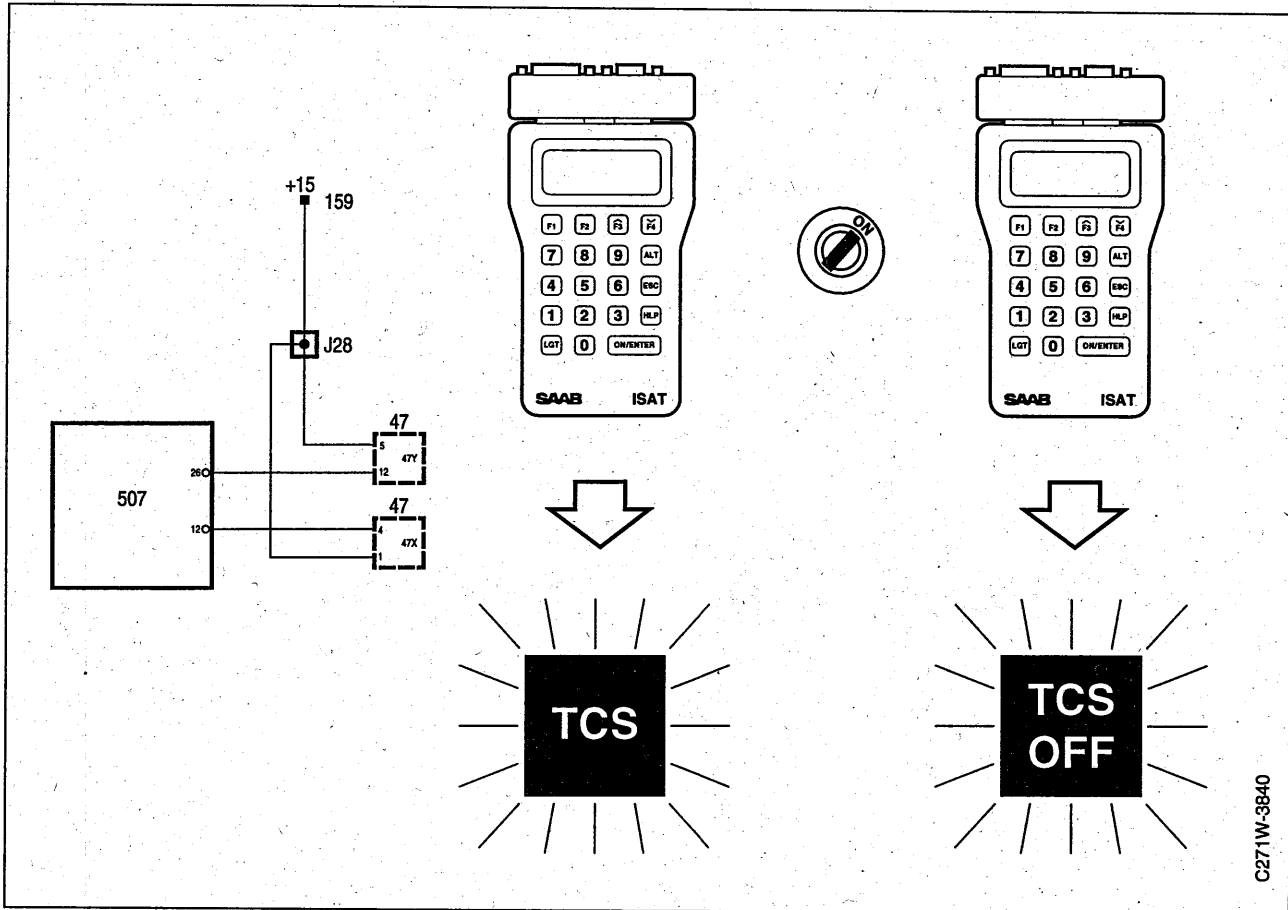

Fault symptom

The lamps do not light or stay lit without a diagnostic trouble code being generated. (Note that the lamps are tested for 3 seconds when the ignition is switched on)

Action

- 1 Activate the lamps using the ISAT "ACTIVATE" menu.

If the lamps do not work, first check that the lamps are not broken.

If the lamps are intact, check the TCS lamp lead for breaks or shorts between control module pin 12 and pin 4 on the instrument. Alternatively check the TCS OFF lamp lead for breaks or shorts between control module pin 26 and pin 12 on the instrument.

Remedy any faulty lead.

C271W-3840

Checking the contr. module's voltage supply and ground conn.

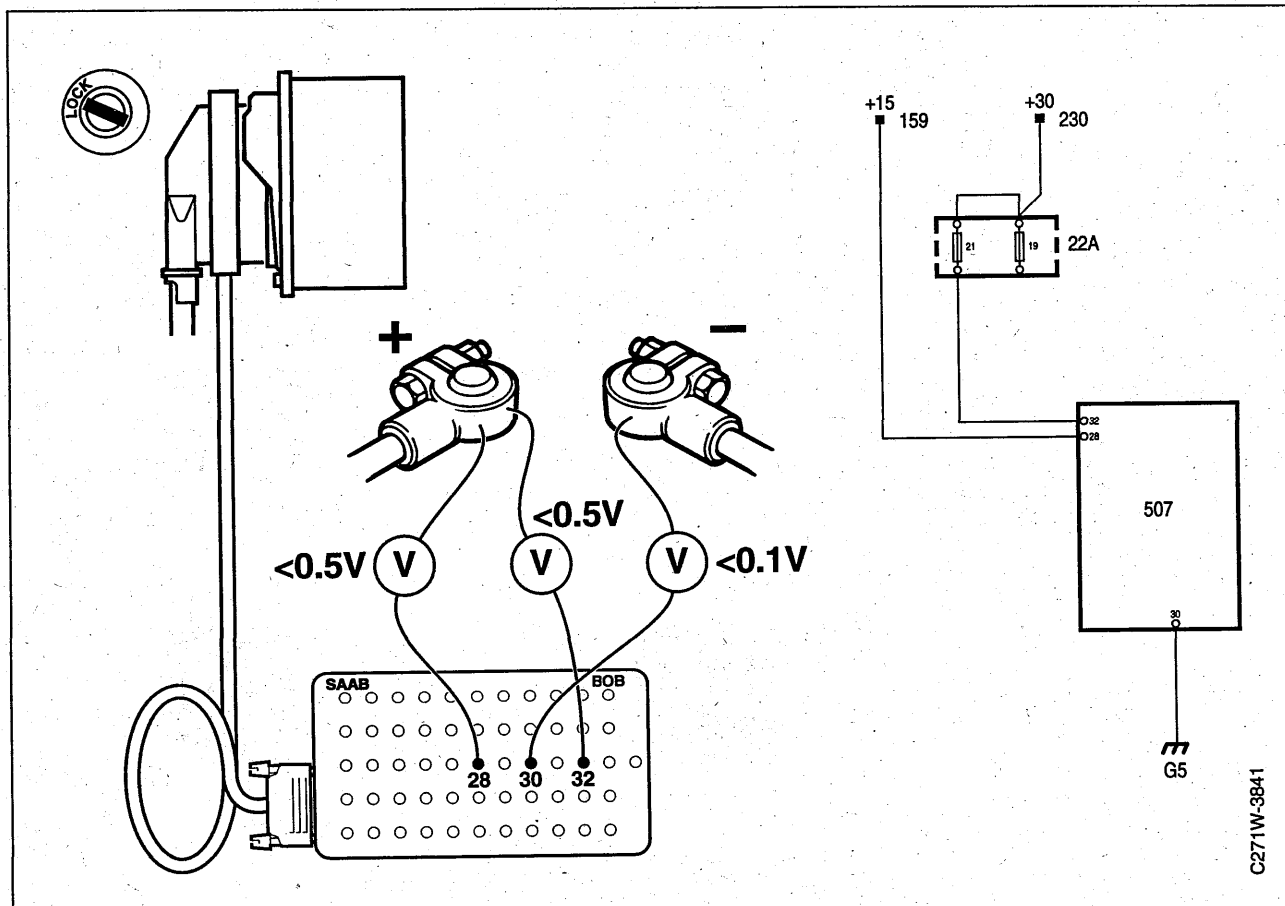

Fault symptom

Alternative I: TCS OFF lamp on, TCS inoperative

Alternative II: TCS OFF lamp and TCS lamp both fail to light when the ignition is turned ON

Alternative III: Malfunctions

Action

When a BOB is connected during trouble diagnosis, the voltage supply and ground connections should always be connected first, as follows:

Ignition in ON position

- 1 Battery positive — pin 32 _____ <0.5 Volts
- 2 Battery positive — pin 28 _____ <0.5 Volts
- 3 Pin 30 — Battery negative _____ <0.1 Volts
- 4 Pin 13 — Battery negative _____ <0.1 Volts

Procedure prior to replacement of a control module

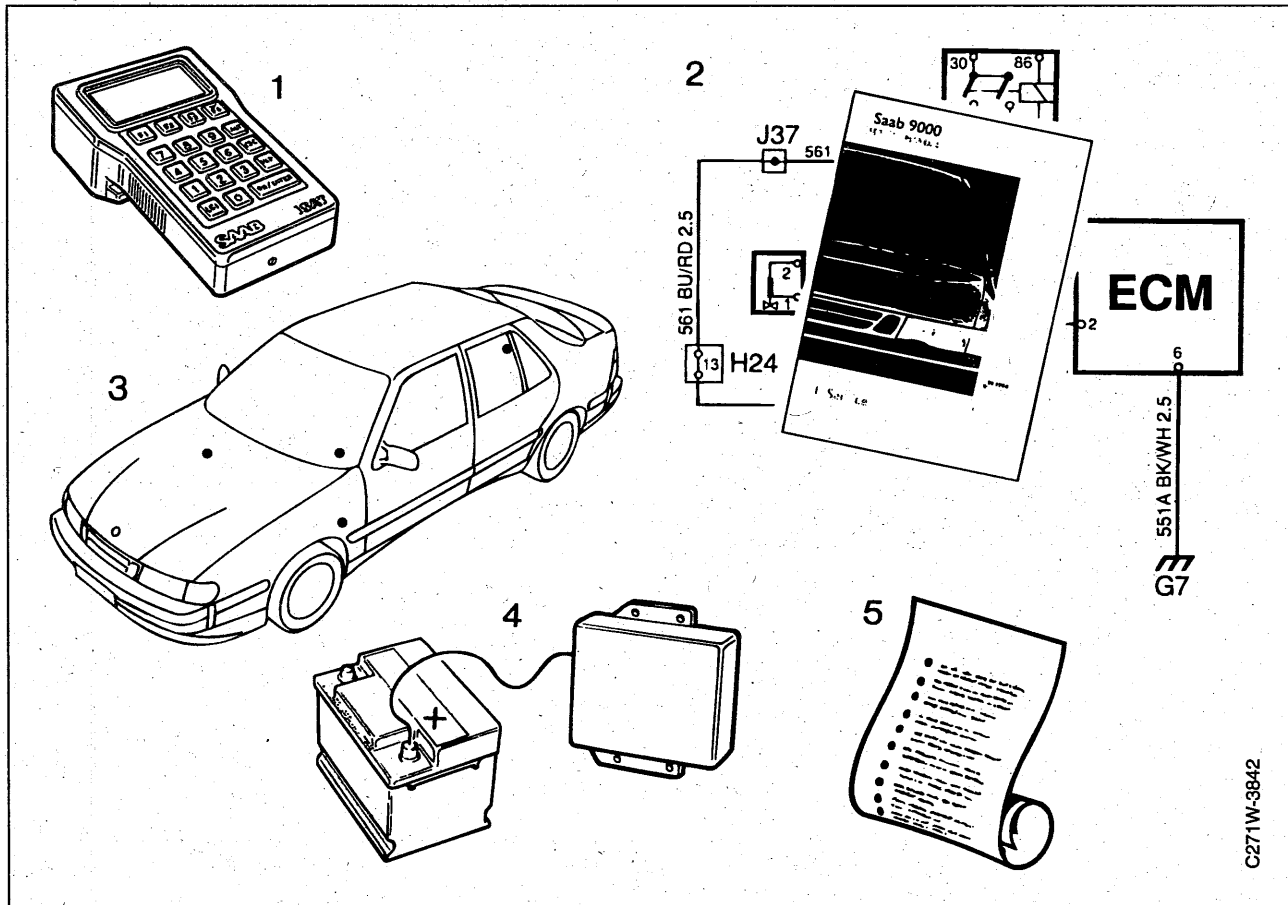

C271W-3842

If it has not been possible to find any fault after everything has been checked in accordance with the diagnostic procedure for the relevant diagnostic trouble code, and separate checking of component operation has also been carried out, it is natural to assume that the control module is defective.

In view of the fact that the control module is both a very high quality and an expensive component, it is important to be as sure as possible of the diagnosis.

Therefore, carefully go through the following points before definitely deciding that the control module is the cause of the fault.

- 1 Check once again that all the points in the relevant diagnostic procedure have been carried out correctly.
- 2 Study the wiring diagram for the relevant circuit and make sure that you understand how it works. If necessary, consult the description of operation and the electrical function description in Service Manual 3:2 Electrical wiring.
- 3 Check the control module's grounding points once again and also check that the relevant grounding points are good.
- 4 Check the voltage supply to the control module.

- 5 Go through the points on page 36 once again and check that you have not overlooked anything.
- 6 Experience from M93 shows that most of the control modules returned for warranty repairs were fault-free. Be selective when changing control modules. Unnecessary changing of control modules is extremely expensive for Saab Automobile and its dealers. Think through possible causes of the fault before changing the control module. If changing the control module for tests, always refit the correct control module.
- 7 If the original fault persists despite this, the TCS must be changed.

Do not forget to program the control module for the correct car variant.

See information on the next page.

Handling control modules

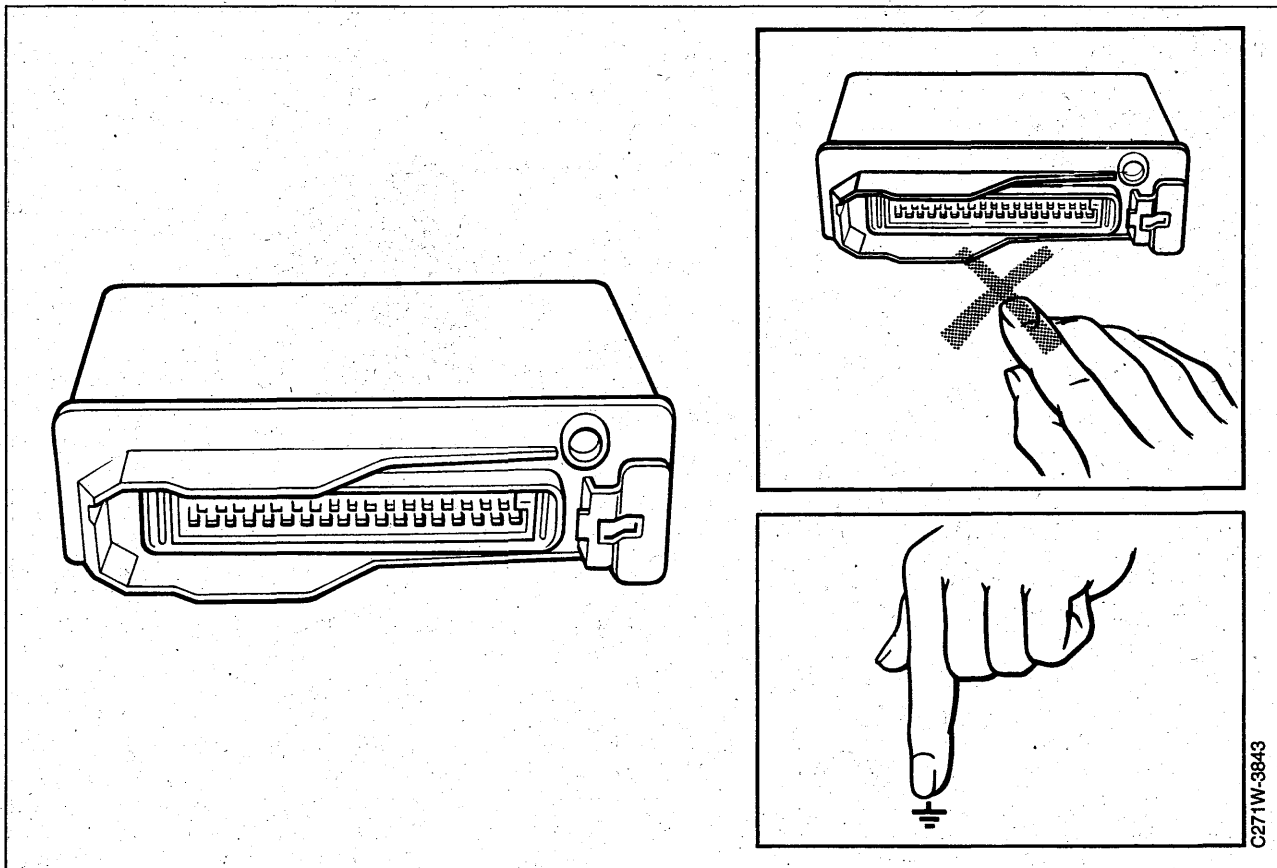

All control modules are more or less sensitive to static electricity and, if handled carelessly, may be damaged so seriously that they no longer work properly. For this reason, it is important that the following rules are followed at all times when a control module is removed or replaced for any reason.

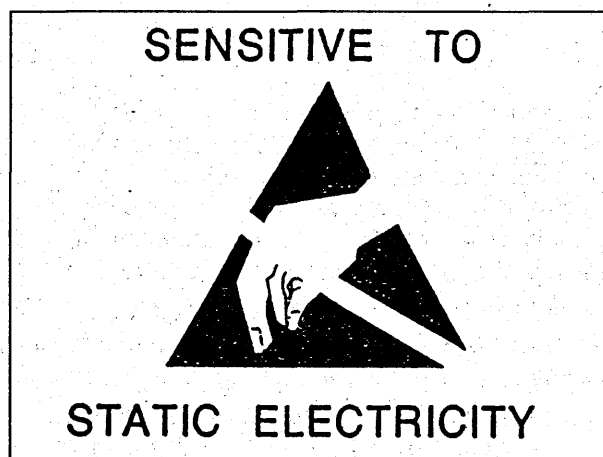

- Avoid unplugging or removing the control module unless absolutely necessary.
- Never touch the connector pins and never place the control module in such a way that the connector pins touch anything else.
- Before unpacking a new control module, ground the packaging to the car's bodywork. Open the packaging as short a time as possible before fitting the module.
- Avoid wearing clothes of synthetic material.

- When working with control modules it is important to regularly ground yourself. This is especially important if you have been sitting in the car, when you have changed position or moved around the car and when working in climate conditions with very dry air (for example during the winter in cold markets).
- Furthermore, always handle control modules which are suspected of being defective in the same way. This will greatly improve the chances of determining the cause of the fault.

Adjusting/changing components

Changing the TCS throttle body	57	Changing the function lamp	61
Changing the TCS control module.	60	Changing the switch	61
Changing the warning lamp	61		

Changing the TCS throttle body

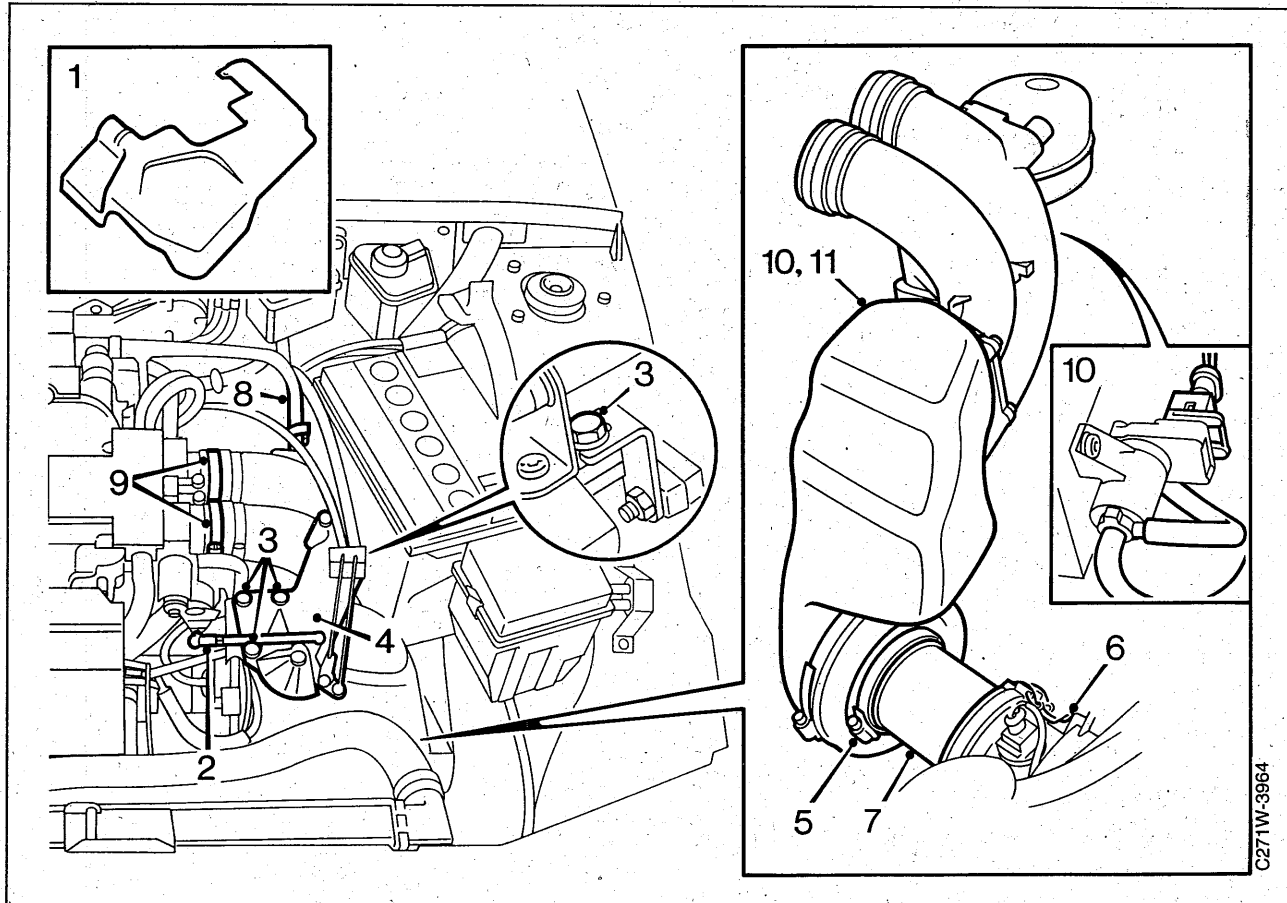

Removal

- 1 Remove the engine covers.
- 2 Disconnect the control rod from the throttle.
- 3 Release the bracket fastenings.
- 4 Remove the control plate bracket.
- 5 Undo the hose clamp securing the mass air flow sensor to the resonator box.
- 6 Open the two snap locks between the mass air flow sensor and the air cleaner.
- 7 Unplug the connectors and remove the mass air flow sensor.
- 8 Remove the idle air control valve hose on the inlet manifold.
- 9 Undo the hose clamps between the inlet manifold and the throttle body.
- 10 Lift the intake manifold complete with resonance box. Remove the two vacuum hoses from the vacuum tank and the outer throttle control valve as well as the electrical connectors for the control valve.
- 11 Remove the intake manifold and the resonance box.

Changing the TCS throttle body (contd.)

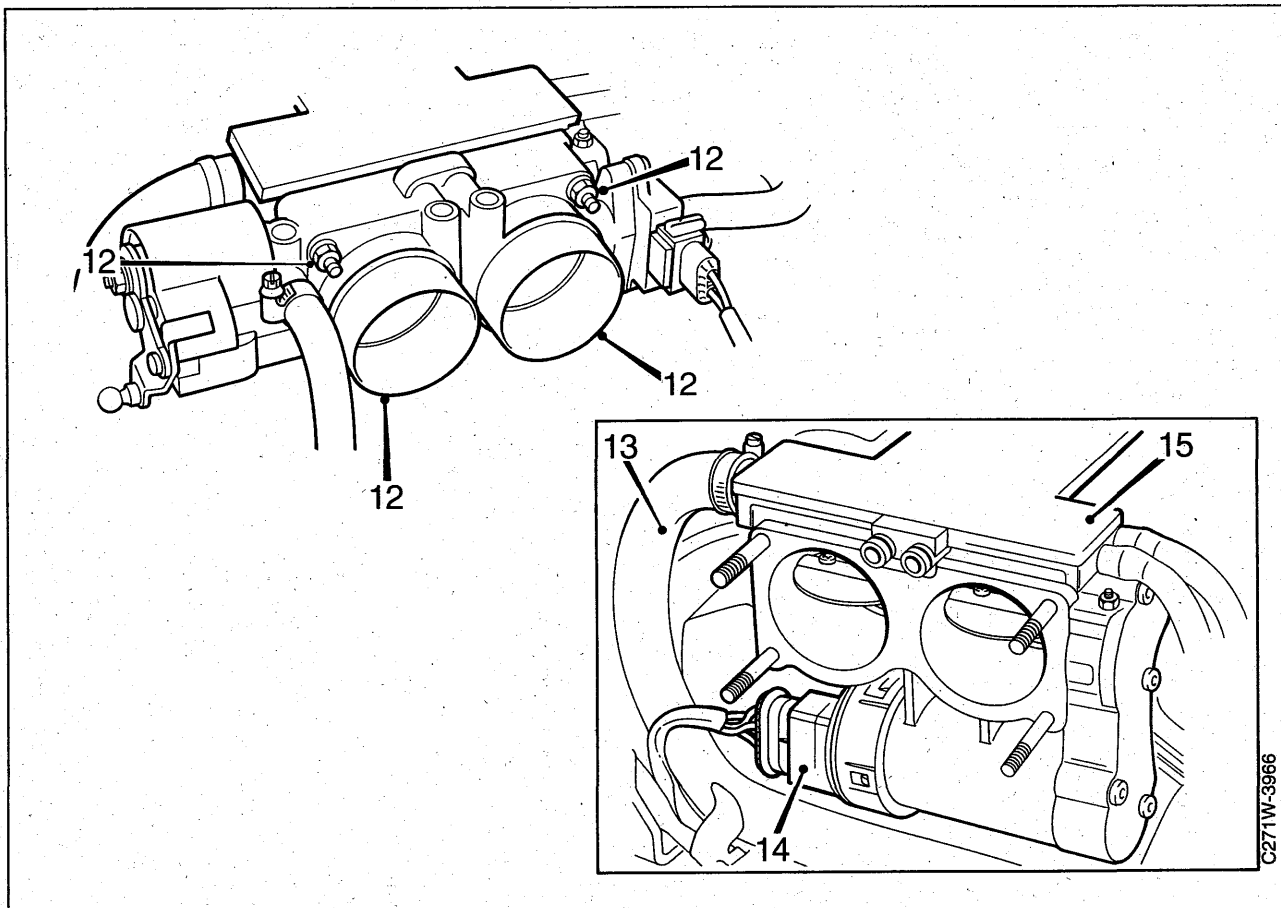

Removal (contd.)

- 12 Remove the four nuts securing the main throttle and the TCS throttle.
Pull out the main throttle and disconnect the hoses.
- 13 Disconnect the crankcase ventilation hoses.
- 14 Unplug the throttle body connectors and carefully lift the vacuum plate.
- 15 Lift away the throttle body.

Changing the TCS throttle body (contd.)

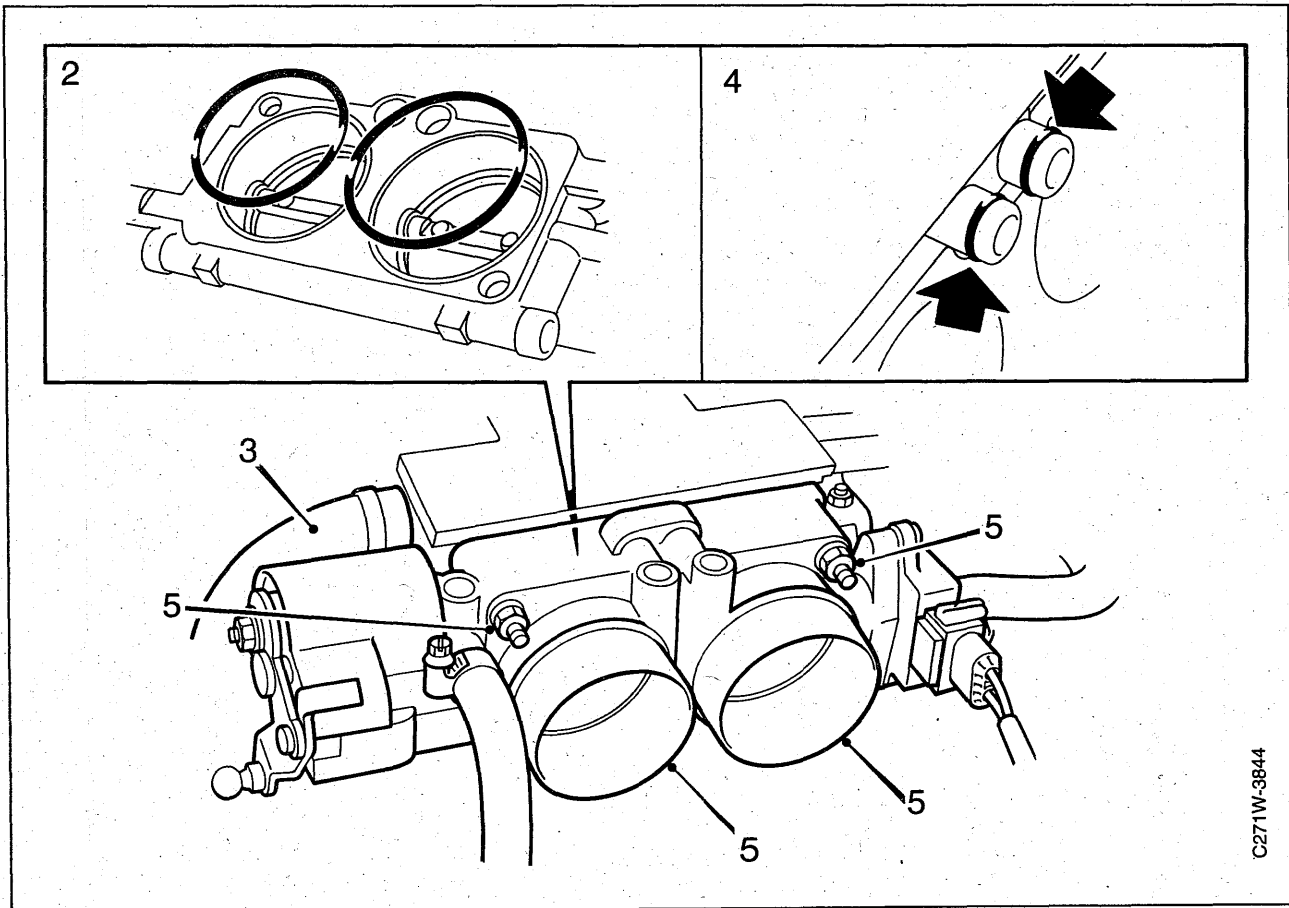

C271W-3844

Fitting

- 1 Clean all contact surfaces between the main throttle body, TCS throttle body and the intake manifold, and clean the surfaces on the intake manifold parting line.
- 2 Check the O-rings in the TCS throttle and lubricate with a little vaseline.
Fit the TCS throttle in place and plug in the connector.
- 3 Connect the hose to the crankcase ventilation.
- 4 Check the O-rings in the throttle body.
Check both O-rings for the vacuum plate and the mating surface. Lubricate with a little vaseline.
- 5 Fit the throttle body in place, attach the cable conduit and tighten the nuts.
Tightening torque: 8 Nm (6 lbf ft)
- 6 Connect all hoses to the throttle body.

- 7 Fit the intake manifold and the resonance box and all other parts that have been removed.

Important

After fitting, check/adjust the throttle cable and the kick-down cable (where fitted) using special tool part No. 87 92 459.

See Service Manual 2:7 motronic 2.8.1.

- 8 Fit the engine covers.
- 9 Test drive and check the TCS is working properly.

Changing the TCS control module

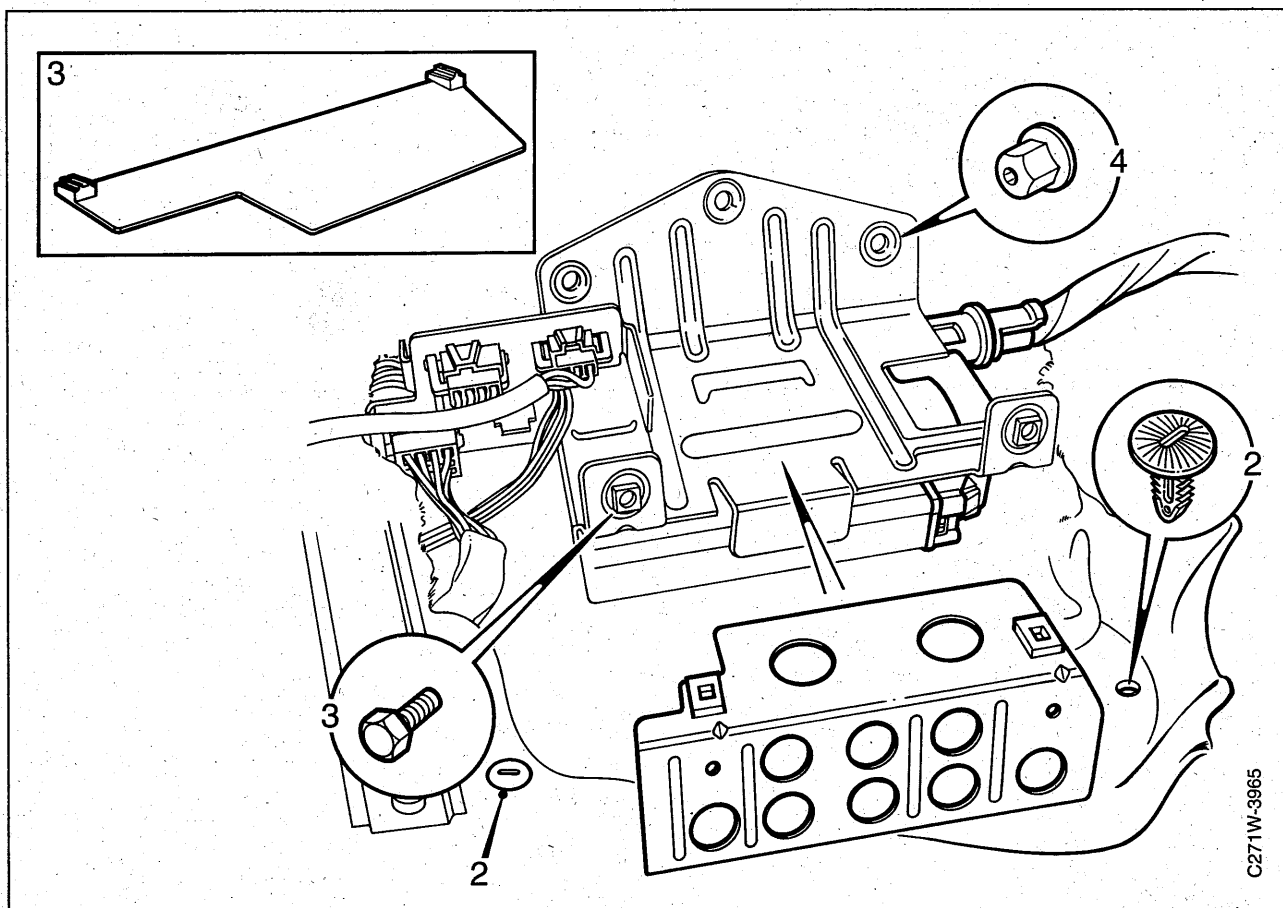

The TCS control module is located under the left-hand front seat.

Removal

- 1 Raise the seat and push it as far forward as possible.
- 2 Remove the two clips securing the carpet and fold it up.
- 3 Remove the two screws securing the rear control module attachment and remove the cover cap.
- 4 Remove the three nuts securing the control module attachment.
- 5 Lift up the control module attachment, unplug the control module connector and lift out the control module.

Fitting

When fitting, ensure that the wiring is correct.

Program the control module with the correct gear-box using the ISAT, see page 35.

Otherwise, fitting is in reverse order.

Changing the TCS OFF warning lamp, the TCS function lamp and the ON/OFF switch

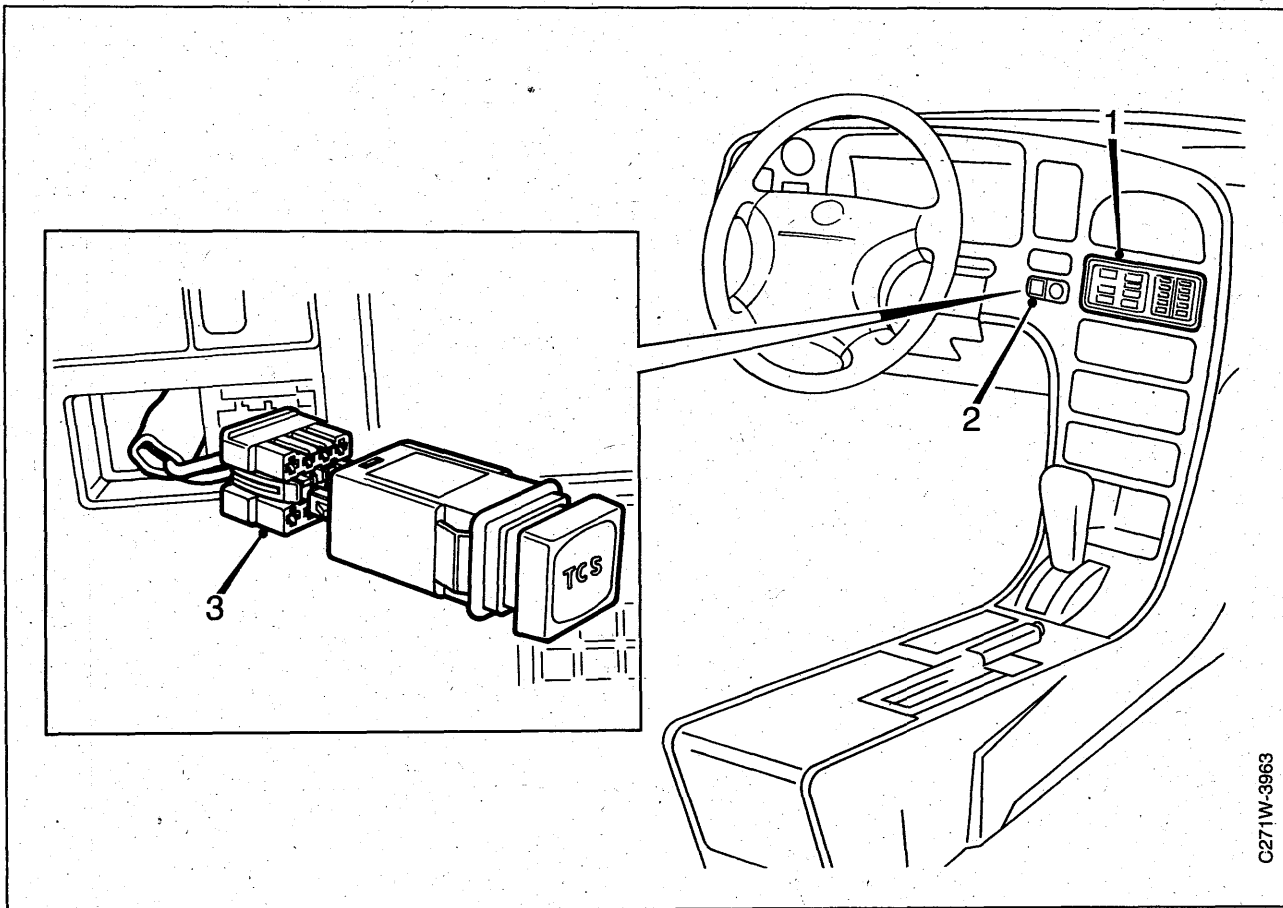

C271W-3963

When changing lamps, see Service Manual 3:5
"Electrical system, instruments".

To remove, switch

- 1 Remove the ACC control panel.
- 2 Press out the TCS switch from the inside of the panel.
- 3 Unplug the TCS switch connector.

Fitting

- 1 Plug in the TCS switch connector.
- 2 Press the TCS switch into its place in the panel.
- 3 Press back the ACC control panel.

Connectors and grounding points

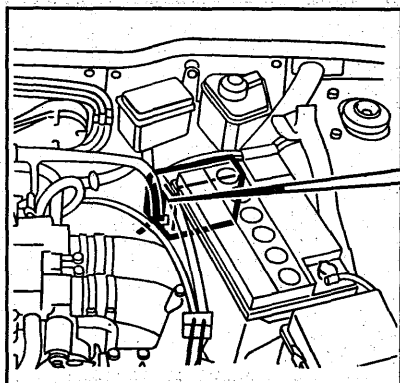

131

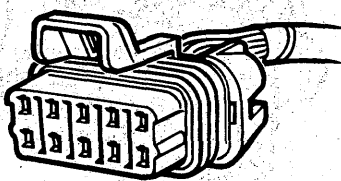

131 Control module, cruise control

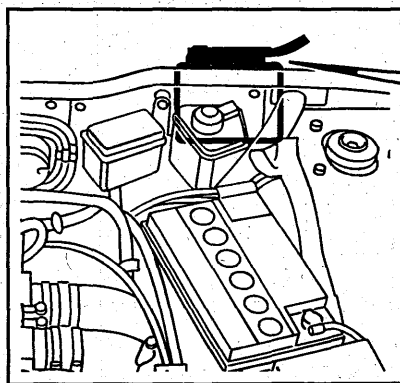

291

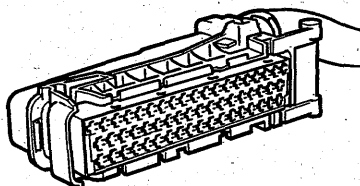

291 Control module, ABS

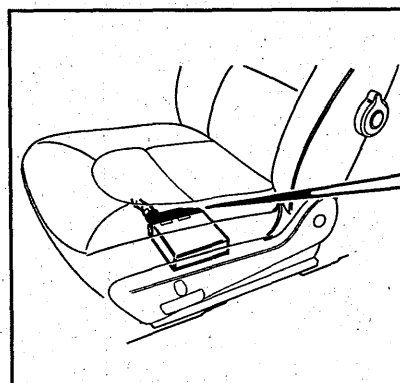

507

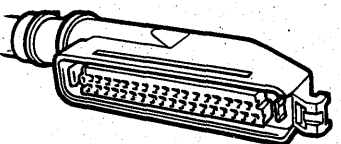

507 Control module, TCS

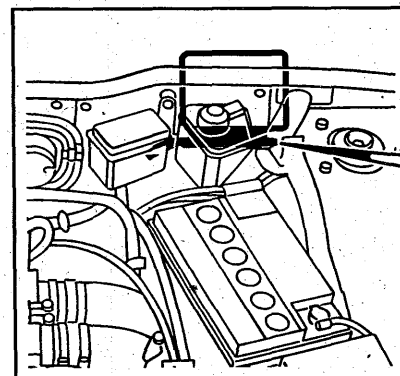

510

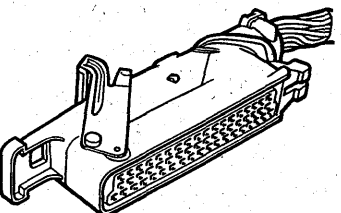

510 Control module, Motronic 2.8.1

C271W-3956

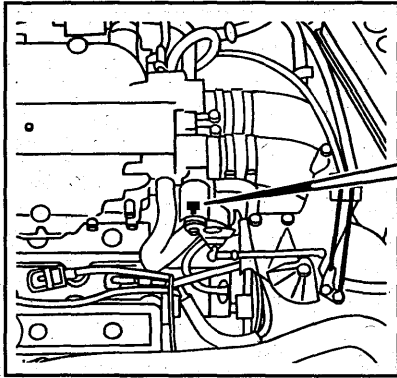

450 Actuator motor, TTS

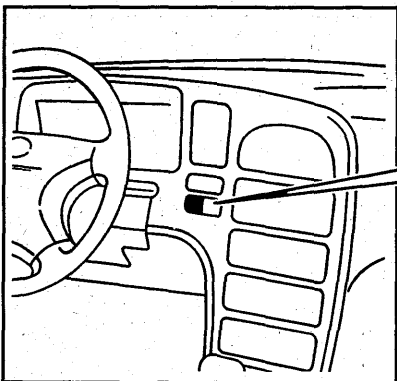
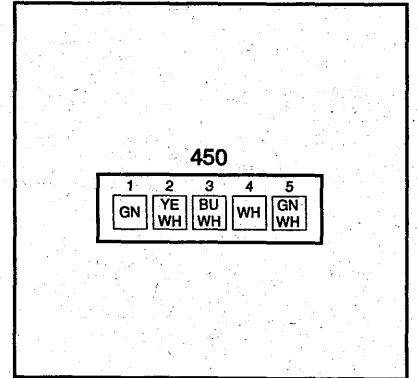
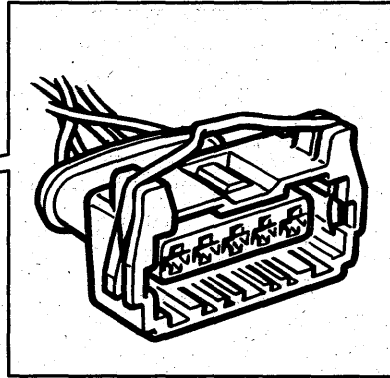

449 TCS switch

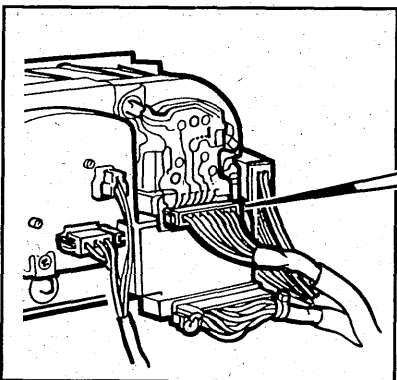
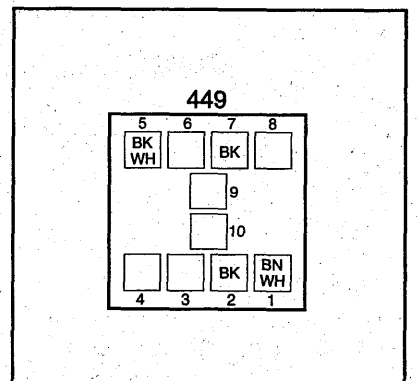
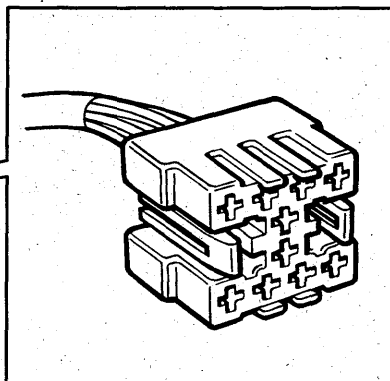

47 (110, 47X) TCS warning lamp

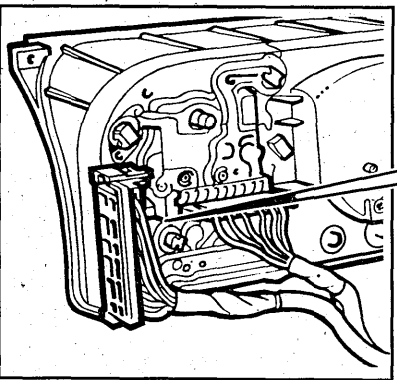
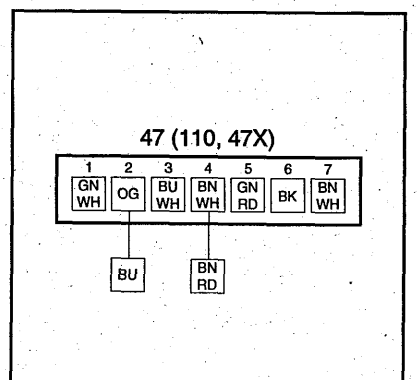
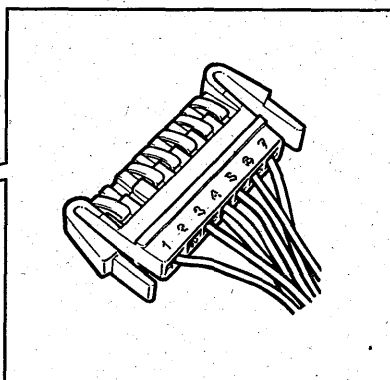

47 (47Y) TCS OFF-lamp

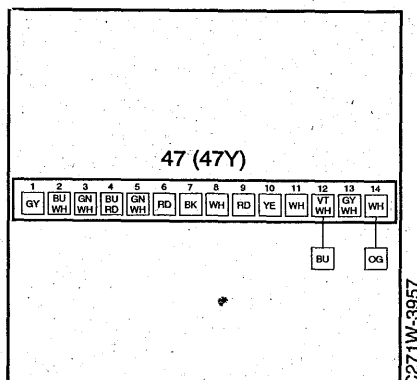
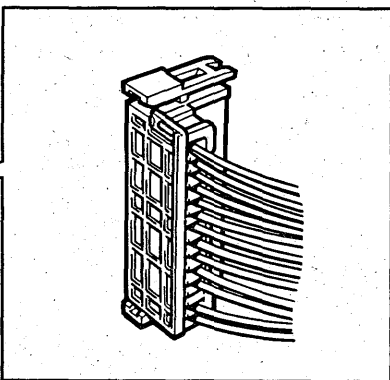

C271W-3957

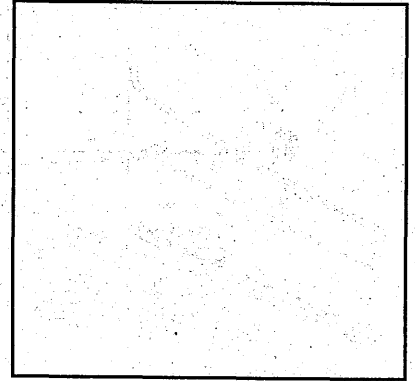
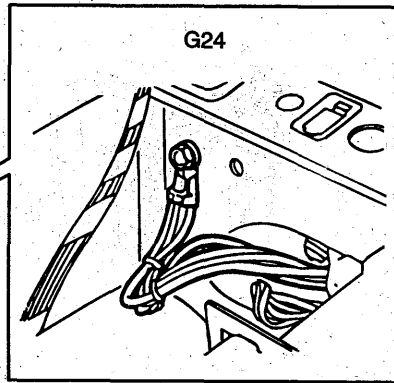
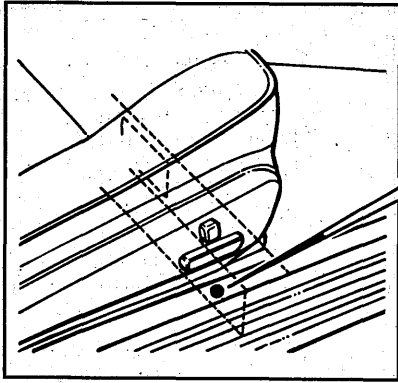

G24 Grounding point

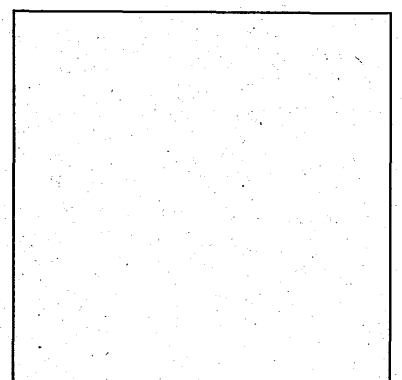
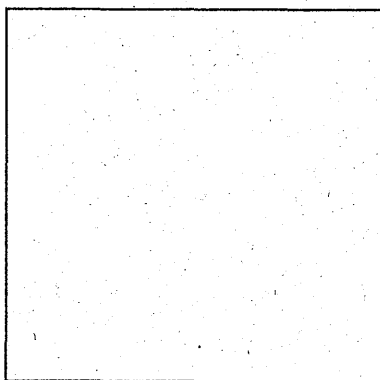
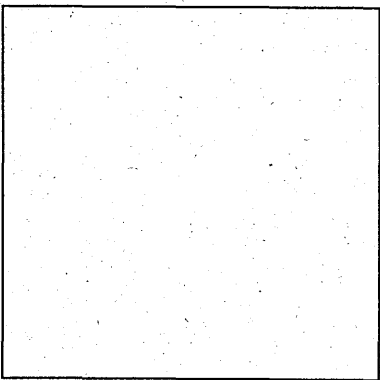
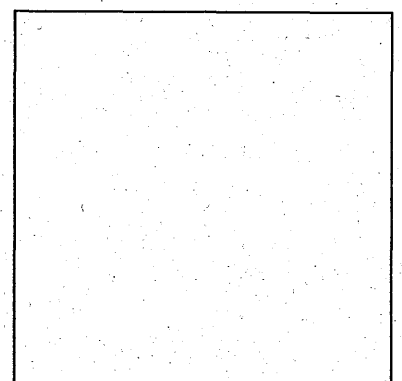
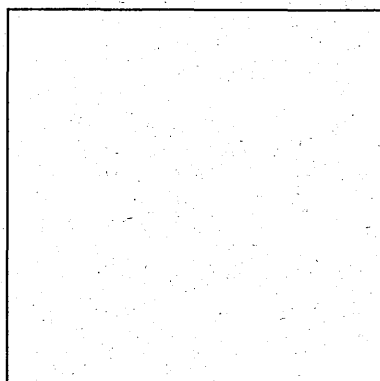
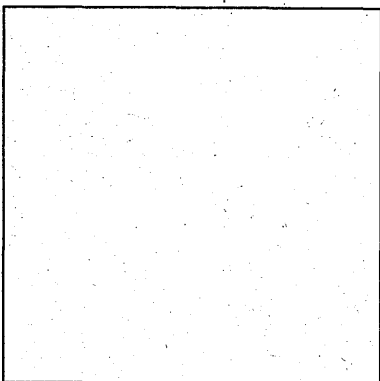
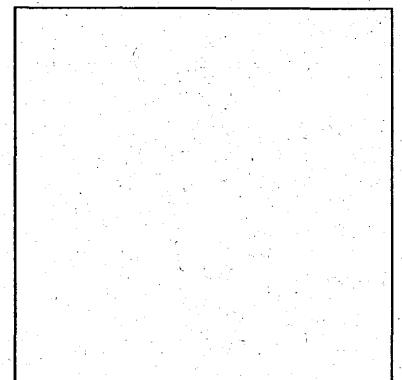
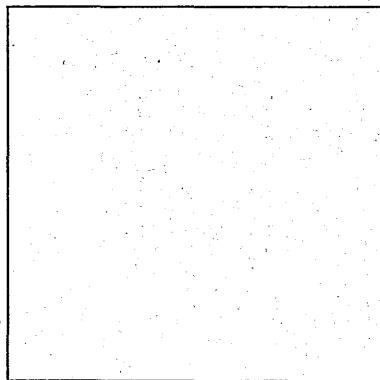
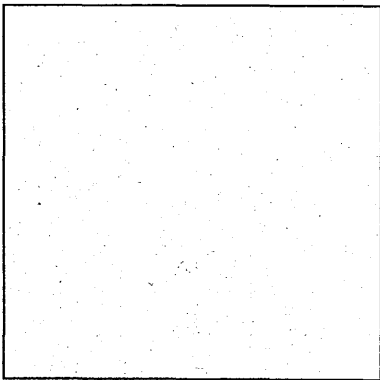

Wiring diagram, TCS

List of components

29	Brake light switch on the pedal bracket
131	Control module, cruise control behind battery on battery shelf
159	Distribution terminal, +15 in the electrical distribution box
230	Distribution terminal, +30 in the electrical distribution box
291	Control module, ABS on the battery shelf behind the battery
47	Combined instrument on the facia behind the steering wheel
450	Actuator motor, TTS
449	TCS switch on the facia
507	TCS control module under the left-hand front seat
510	Motronic control module 2.8.1 in the bulkhead space
H70-1	70 pin connector, engine/main grid
G8	Grounding point, facia
G5	Grounding point, rear seat
G24	Grounding point, right-hand front seat member
H10-9 (348)	Diagnostic data link connector, under right-hand seat (green)
J32	Crimped connector (LHD): Approx. 190 mm from the brake light connector facing the central console (main grid). Crimped connector (RHD): Approx. 190 mm from the brake light connector facing the central console (main grid)
J51	Crimped connector approx. 275 mm from the diagnostic data link terminal under the right-hand front seat (main grid).
J28	Crimped connector (LHD): Approx. 310 mm from the EDU (main grid) Crimped connector (RHD): Approx. 230 mm from the EDU (main grid)
22A	Central fuse box in the glove compartment (or under the passenger airbag)

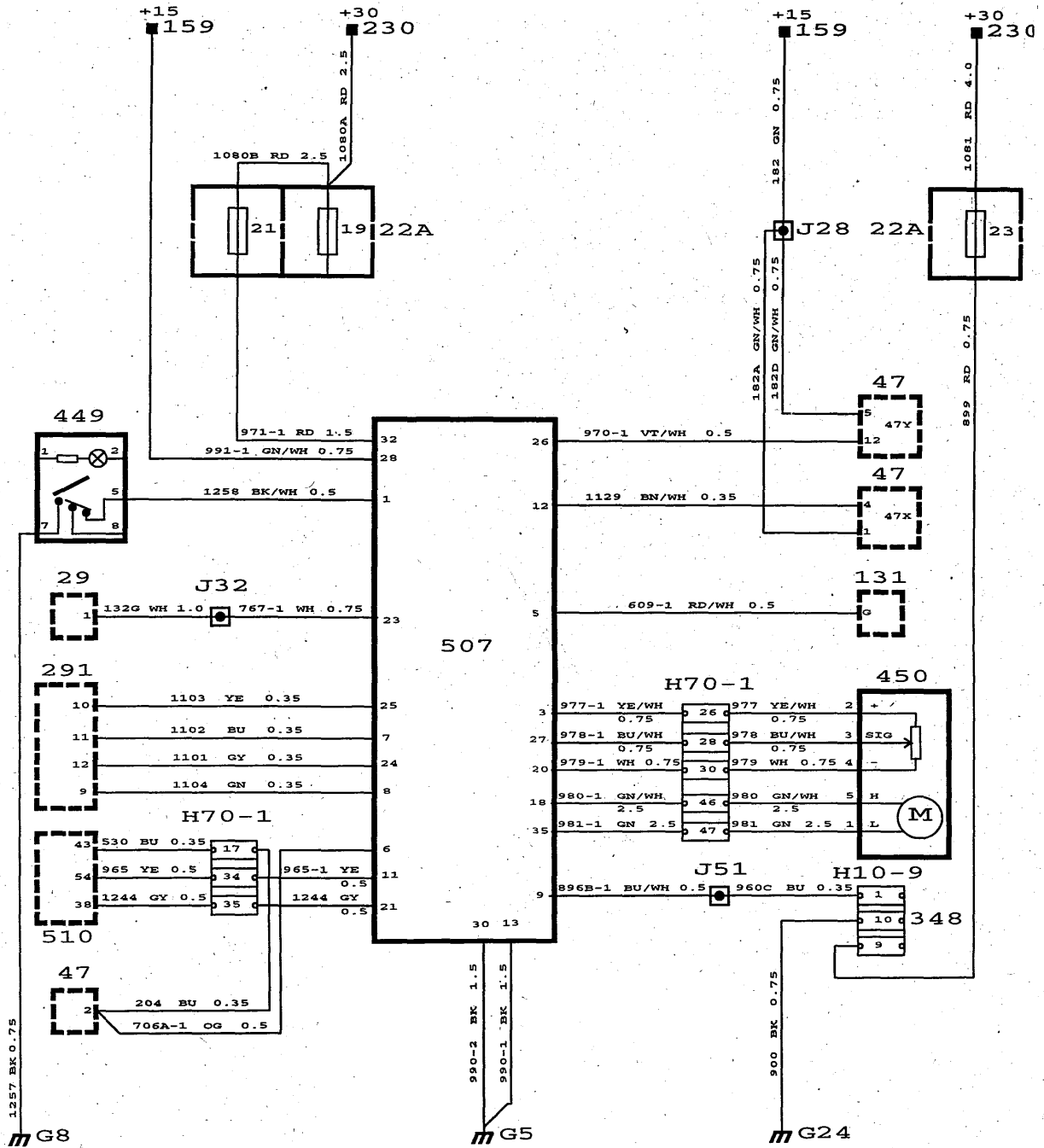



SAAB

Saab Automobile AB
Trollhättan, Sweden



Ordering No. 358010. English edition. Printed in Sweden. © Saab Automobile AB, 1994.

