

# Saab 9000

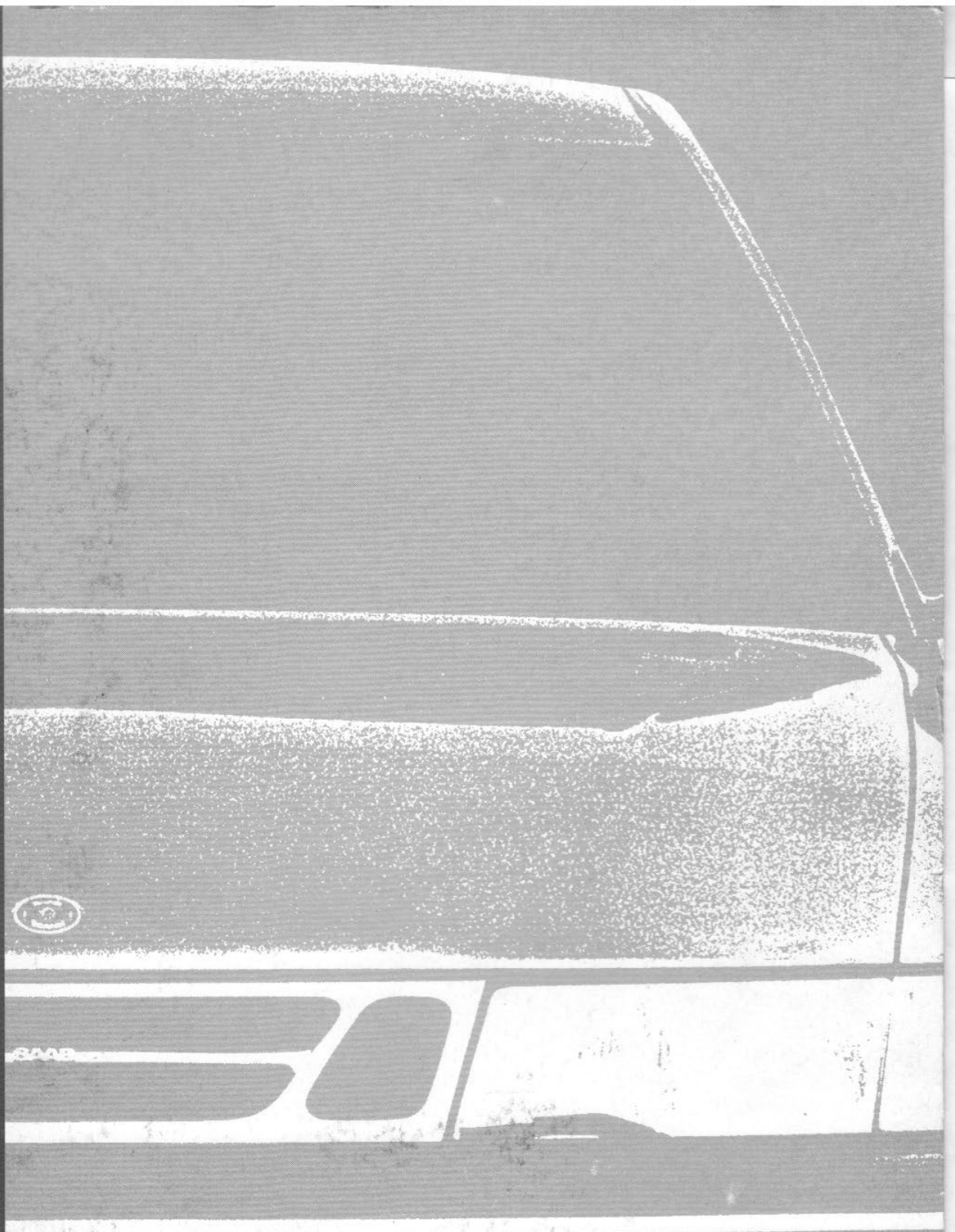

SERVICE MANUAL

## 2:5 Traction information Manual

M 1991-95



**SAAB**

# Saab 9000

## SERVICE MANUAL

### 2:5 Traction Information Manual M 1991-1995

#### Foreword

TIM is designed to assist and simplify fault tracing and repair of only the most common TCS problems on Saab 9000 cars. TIM is not a substitute for the existing TCS Service Manual, Section 2:5, but instead a supplement intended to be used in conjunction with the Service Manual.

Saab Automobile AB

Handling procedures	4
Tools and equipment	10
Information codes	18
Diagnostic procedures	28
ETS reference graphs	92
Calibration	128
Final road test	132
Wiring diagrams	135



RECYCABLE PAPER

## Warning, Important and Note

The headings "Warning", "Important" and "Note" occur from time to time in the Service Manual. They are used to draw the attention of the reader to information of special interest and seriousness. The importance of the information is indicated by the three different headings and the difference between them is explained below.

### WARNING

Warns of the risk of material damage and grave injury to mechanics and the driver, as well as serious damage to the car.

---

### Important

Points out the risk of minor damage to the car and also warns the mechanic of difficulties and time-wasting mistakes.

---

### Note

Hints and tips on how the work can be done in a way that saves time and labour. This information is not supplied for reasons of safety.

### Market codes

The codes refer to market specifications

AT	Austria	GB	Great Britain
AU	Australia	GR	Greece
BE	Belgium	IS	Iceland
CA	Canada	IT	Italy
CH	Switzerland	JP	Japan
DE	Germany	ME	Middle East
DK	Denmark	NL	Netherlands
ES	Spain	NO	Norway
EU	Europe	SE	Sweden
FE	Far East	US	USA
FI	Finland	UC	US California
FR	France		

# TIM

## TCS Information Manual

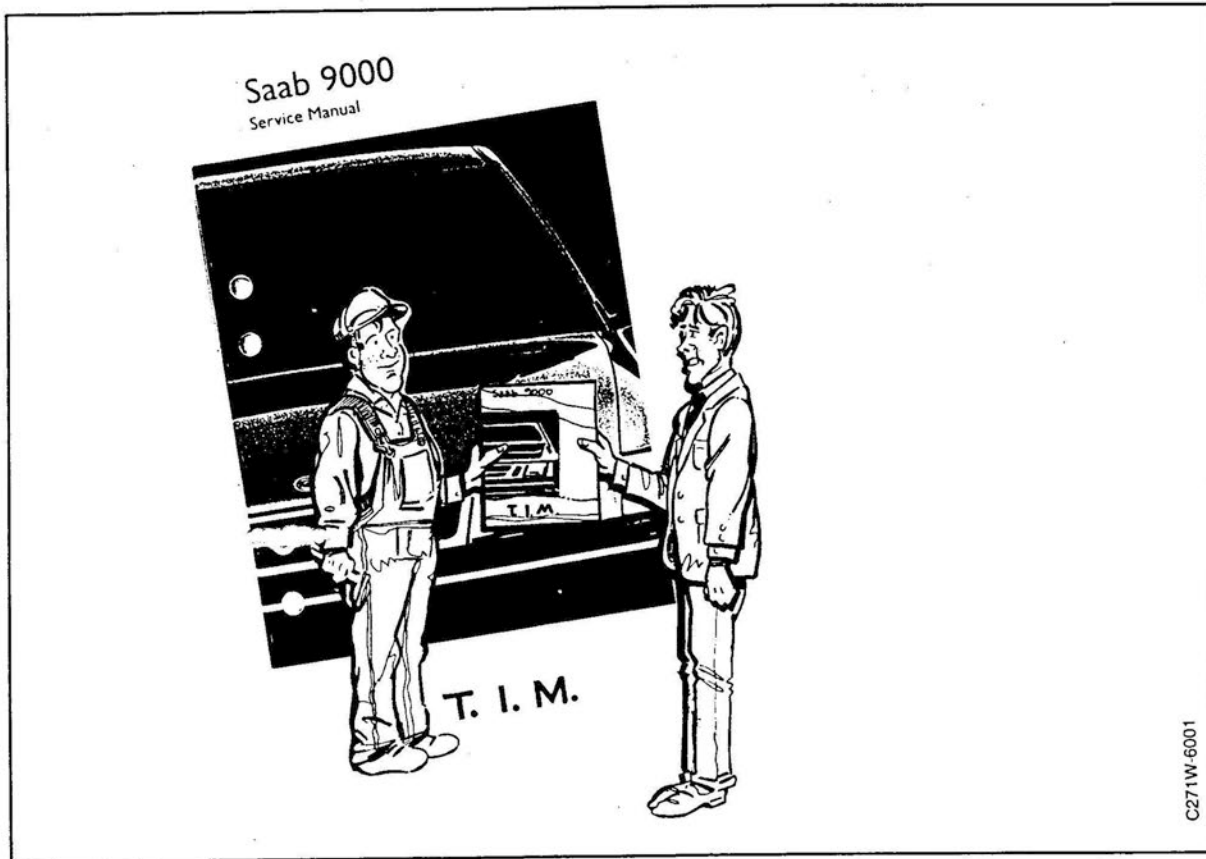

C271W-6001

### PURPOSE

To assist in fault diagnosis when working on the **TRACTION CONTROL SYSTEM** fitted to Saab cars.  
Goal – “**FIX IT RIGHT FIRST TIME**”.

### KNOW-HOW

You are expected to have a reasonable understanding of how the Traction Control System works. If you do not, please refer to Service Manual 2:5 for an explanation of system operation.

### SAFETY

You should take the necessary **precautions** in your work at all times to avoid accidents and injury, particularly observing important **HEALTH** and **SAFETY** regulations.

### CARE

The TIM should be well looked after and regularly updated. Take it with you when you go to the **TRAINING SCHOOL**.



### General rules for fault diagnosis

Many components that our tests show to be in perfect condition are still being replaced.

To avoid the replacement of components in perfect condition, the following steps should always be taken.

- If diagnostic trouble codes are obtained, check the operation of the relevant components or system using a Scan Tool as described in Service Manual 2:5 and/or in this manual. All importers have been supplied with this Manual. It contains selected information explaining how to diagnose faults and rectify them.
- Check the wiring and connectors for continuity, poor contact, damaged connecting pins, etc. Use "KONTAKT 61"; part No. 45-30 04 520, which is an aerosol contact cleaner lubricant with good long-term reliability specially developed for electrical connectors and switches.
- When changing several components at the same time, make sure that the components really are defective before fitting replacements.

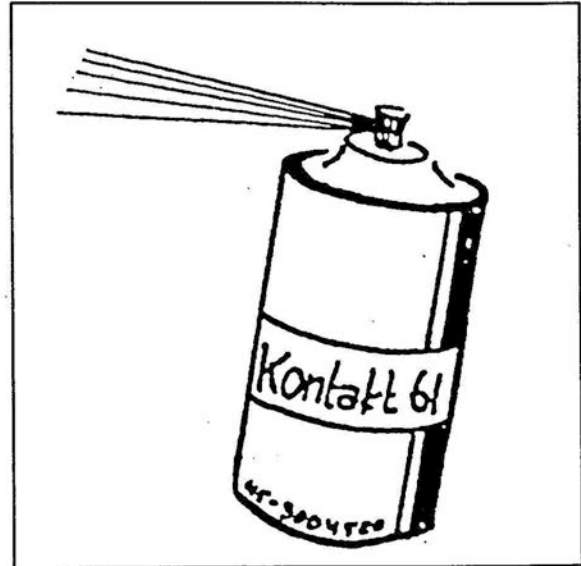

# Index

## Testing procedures

- Customer contact and preliminary inspection ... (page 4)
- Workshop inspection ..... (page 5)
- Before the road test ..... (page 6)
- Road test ..... (page 8)
- After the road test ..... (page 9)

## Tools and equipment

- Dos and don'ts of testing ..... (page 10)
- Saab special tools ..... (page 13)
- Saab recommended tools ..... (page 15)
- Quick-reference parts list ..... (page 16)

## Information codes

- Command codes ..... (page 18)
- Version codes ..... (page 20)
- Calibration ..... (page 22)
- Diagnostic Trouble Codes (DTCs)  
(Quick reference) ..... (page 23)

## Diagnostic procedures

- Component identification and testing ..... (page 28)
- Fault diagnosis/replacement of diodes in  
the ABS-TC/ABS system ..... (page 48)
- Pin and wiring checks ..... (page 62)
- DTC fault diagnosis charts ..... (page 70)

## ETS reference graphs

- ETS reference graphs ..... (page 92)

## Calibration

- Kick-Down Cable adjustment ..... (page 128)
- Calibration (AUT) ..... (page 129)

## Final road test

- Road test ..... (page 132)
- Re-check for DTC's ..... (page 133)
- Inform customer of repairs ..... (page 133)

## Wiring diagrams

- TCS (man. aut. M91-95) ..... (page 135)

## Testing procedures

### Customer contact and preliminary inspection

**Note**

Before touching the car, try to obtain as much information as possible about the nature of the fault.

**Action:**

ASK, LOOK AND LISTEN.

#### ASK

- Talk with the driver of the car and ask him about the fault.

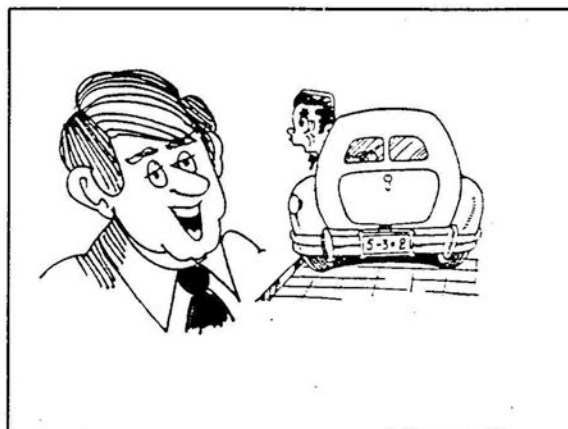

#### LISTEN

- When did the fault occur and what were the symptoms?
- Was the accelerator harder to depress and was engine response different?

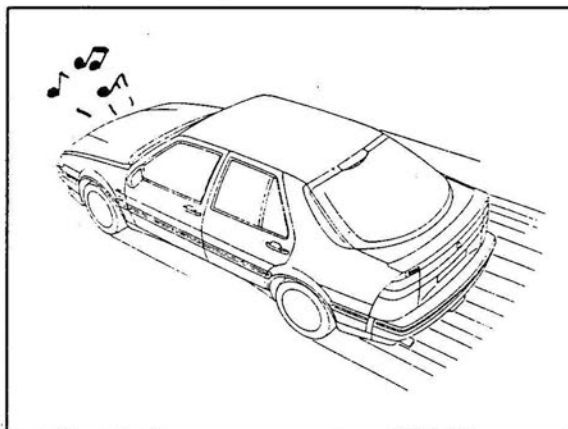

#### LOOK

Did any warning or indicator lamps come on?

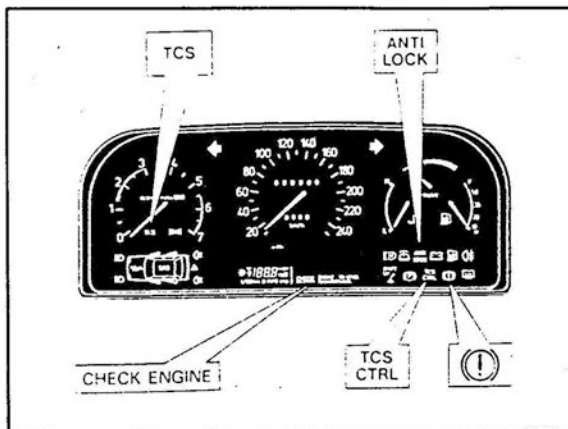

## LISTEN

- Did the car restart OK?

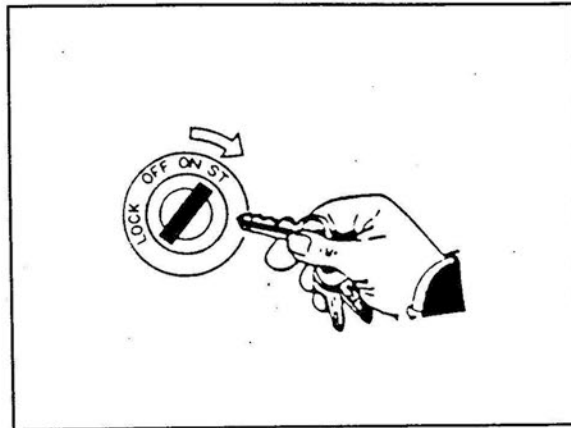

## Workshop inspection

### Action:

LOOK and LISTEN.

### Note

Carry out a visual inspection of the car but **do not touch anything.**

## LOOK

Look for broken components and loose connections under the bonnet.

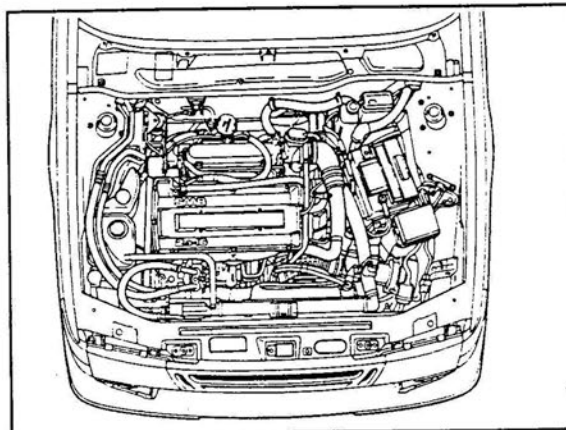

## LISTEN

Listen to the engine. Is it running OK?

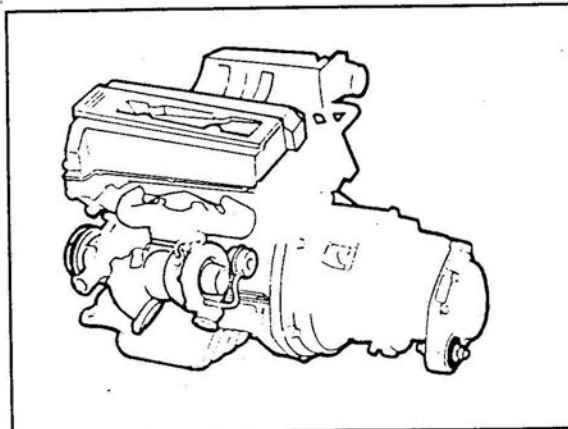

### LOOK

Look to see if any extra equipment is fitted. If it is, it may be affecting the TCS. Check that the mobile phone, anti-theft alarm, etc. are correctly installed.

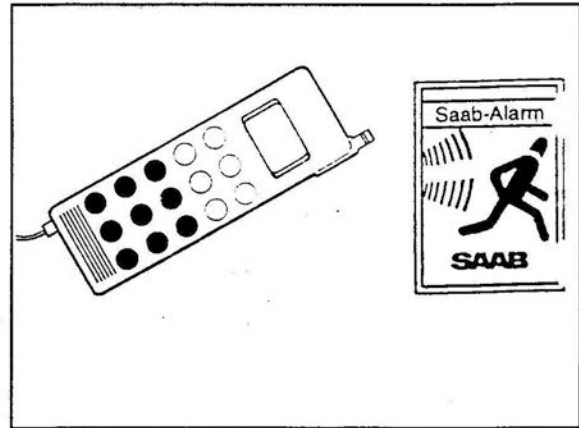

### LOOK

Are any warning or indicator lamps on?

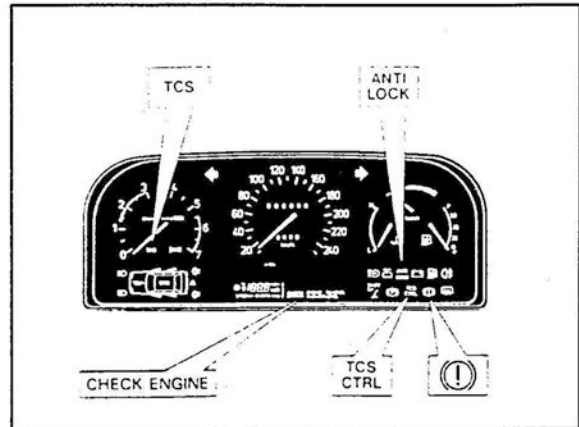

## Before the road test

### Action:

READ Diagnostic Trouble Codes (DTCs).

### CONNECT A SCAN TOOL

Plug the scan tool into a data link connector (green or black) under the right-hand front seat.

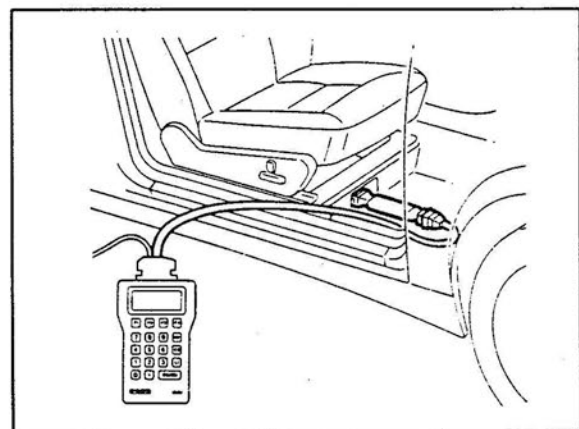



**READ THE DTCs**

Carry out fault diagnosis on all systems from both the green and black data link connectors and make a note of all the diagnostic trouble codes.



C271W-6011

**CLEAR THE DTCs**

Clear the trouble codes in all systems but **do not recalibrate** any systems at this time.

**Power Off test**

It has been found that DTCs can be generated in other systems on certain models during the ETS system Power-Off test (performed each time the ignition is switched off) while the scan tool is still connected. On all models it is therefore advisable to terminate scan tool communication **before switching OFF** the ignition.

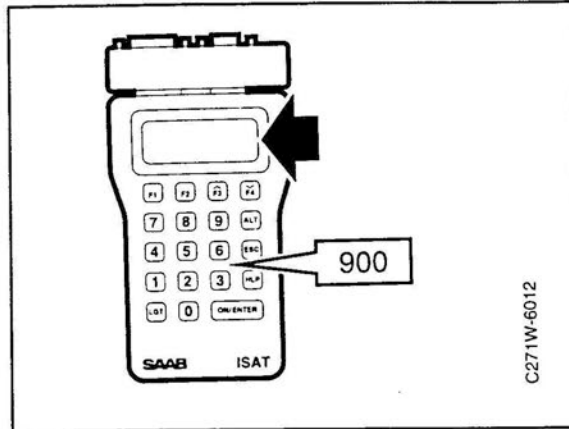

C271W-6012

"System reset to zero"

**ENTER COMMAND CODES**

Enter command codes according to the DTCs obtained as described above. Refer to "Command Codes" on page 18.

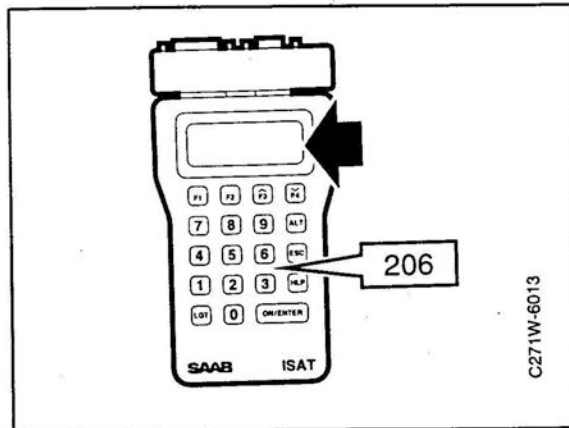

C271W-6013

"Brake light switch"

## Road test

### Before the Road Test

A) Reset the trip meter to zero.

B) Note the engine temperature.

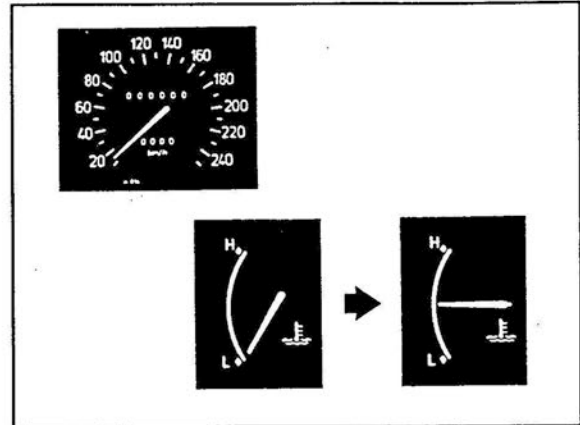

### During the Road Test

A) Check the boost pressure.

B) Check the Cruise Control system.

C) Check shifting performance (automatic transmission).

D) Activate the TCS (provoke wheelspin).

E) Watch the warning lamp display.

F) Listen to the sound of the engine.

G) Does the accelerator work OK?

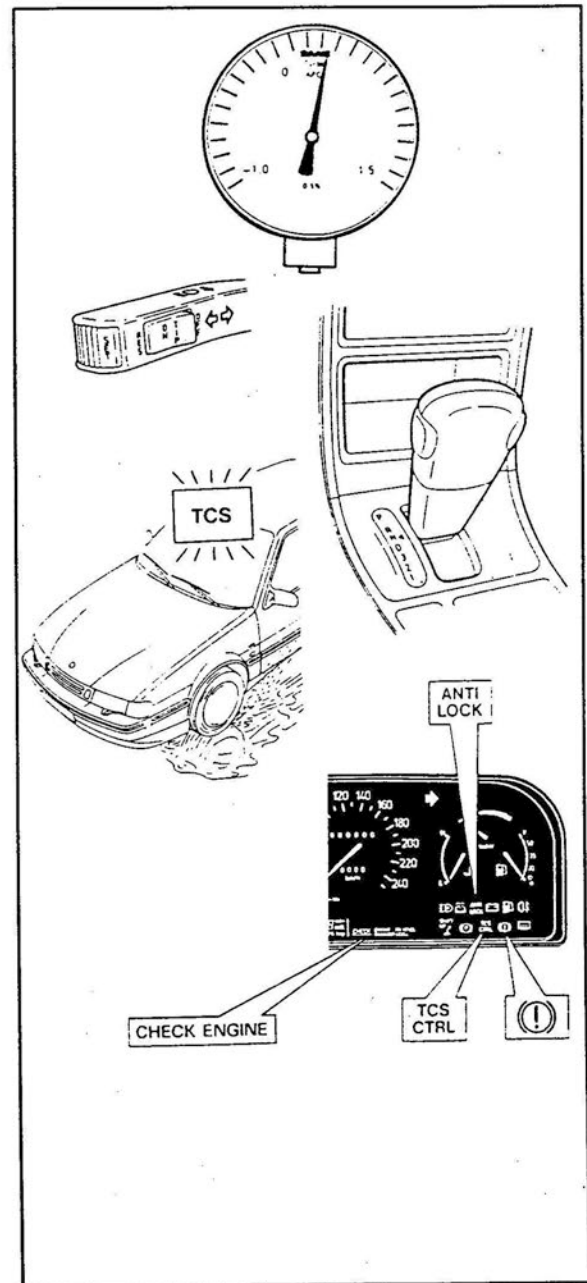

## After the Road Test

**Action:**

Re-check the DTCs as described in "Before the road test".

**Power-off test**

It has been found that DTCs can be generated on certain models during the ETS system Power-Off test (performed each time the ignition is switched off) while the scan tool is still connected. On all models it is therefore advisable to terminate scan tool communication **before switching OFF** the ignition.

**NEW CODES**

Proceed to the DTC fault diagnosis charts on page 70 and deal only with these new codes in sequential order.

Refer to page 70  
**DTC fault diagnosis charts.**

**NO NEW CODES**

Refer to the original codes noted during "Before the road test". Proceed to the DTC fault diagnosis chart on page 70 and deal with each code in sequential order.

Refer to page 70  
**DTC fault diagnosis charts.**

## Tools and equipment

### Dos and don'ts of testing

#### DON'T

Do not use extra leads to make **jumper** or **bridging** connections (when obtaining readings via a BOB).

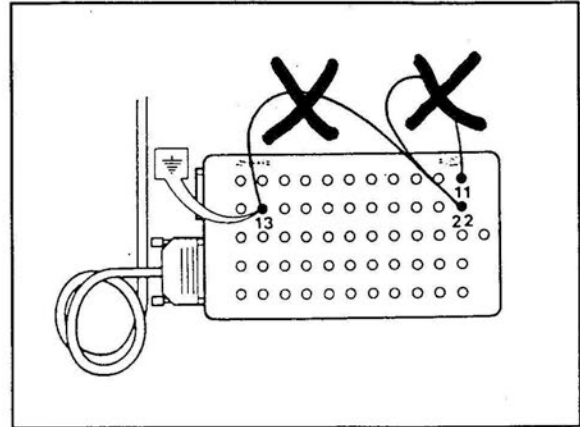

#### DON'T

Never take readings by applying test probes to the **connector side**.  
(Use a breakout lead, part No. 4066916).

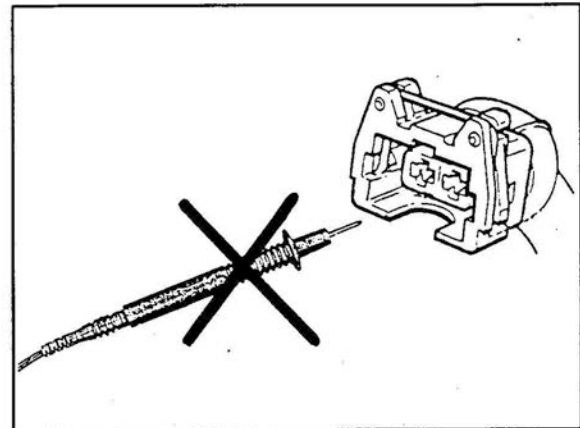

#### DON'T

Never disconnect any electrical components when the **ignition is switched ON**.

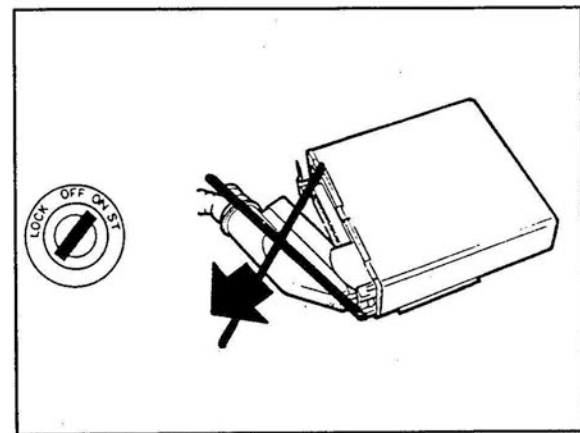

## Dos and don'ts of testing (contd.)

### DON'T

Do not overload your equipment. Remember what you are testing and select the right scale.

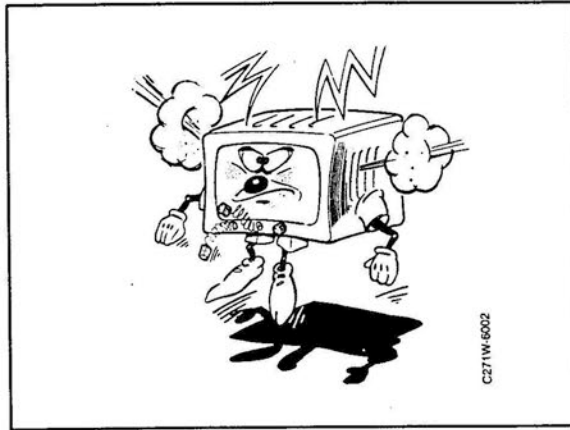

### DON'T

Do not charge the battery without disconnecting it from the car.

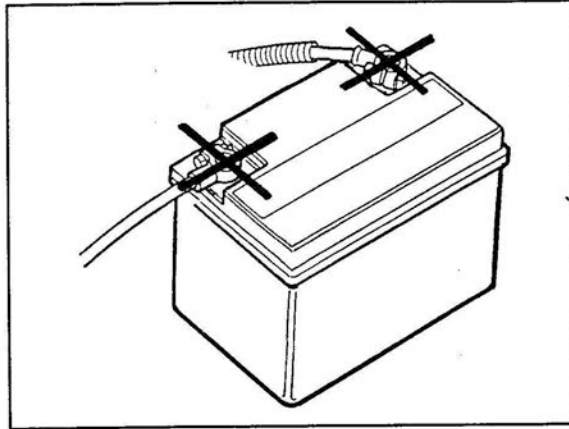

### DO

Always use a Breakout Box (BOB) when taking test readings.

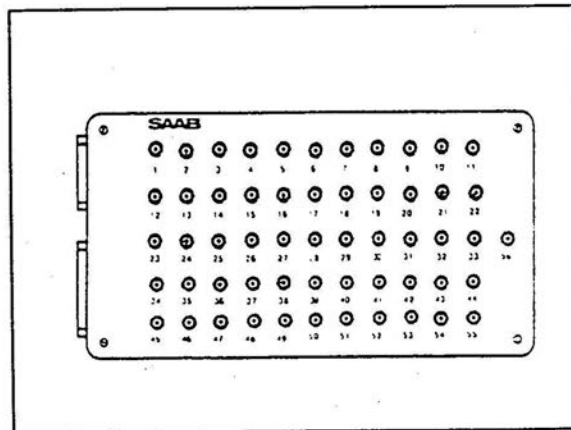



## Dos and don'ts of testing (contd.)

### DO

Do bear in mind the possibility of extra equipment, such as

- car phone
- theft alarm
- etc. affecting the TCS.

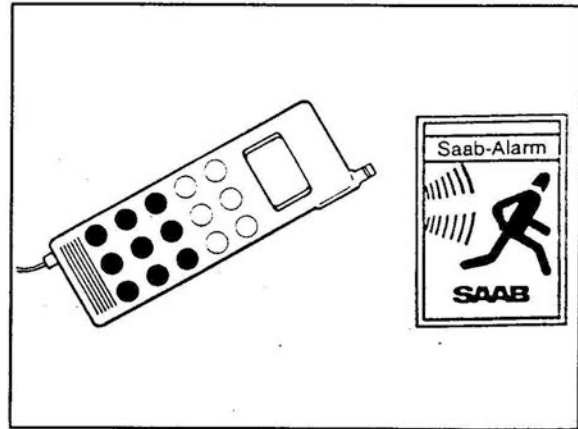

### DO

Take test readings more than just once to confirm the results. Perhaps check with an oscilloscope.

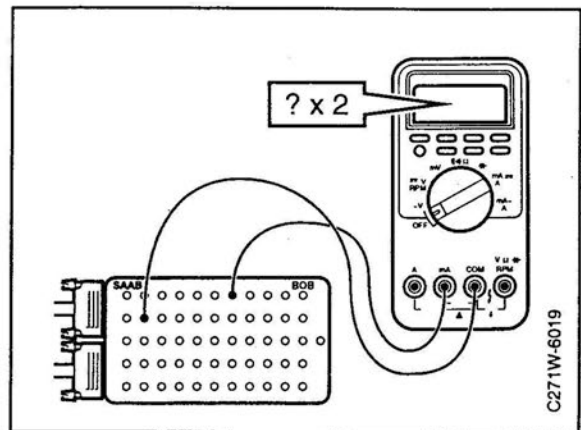

### REMEMBER

Poor quality tools give poor quality results!

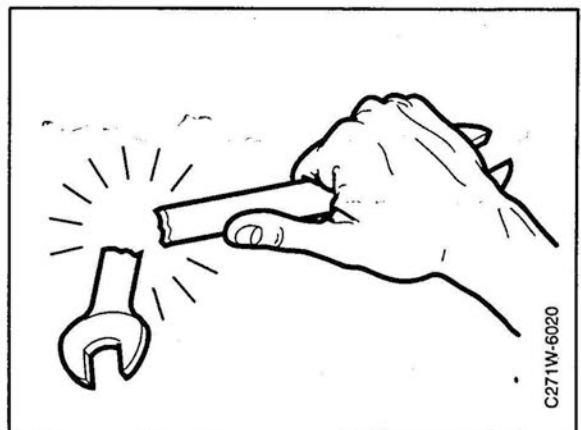

# Saab Special Tools

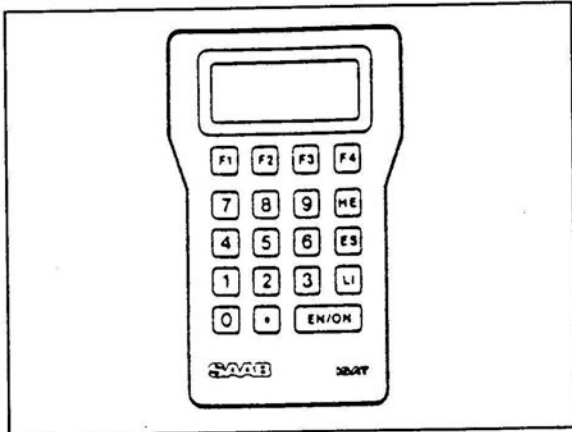

Scan tool 86 10 834

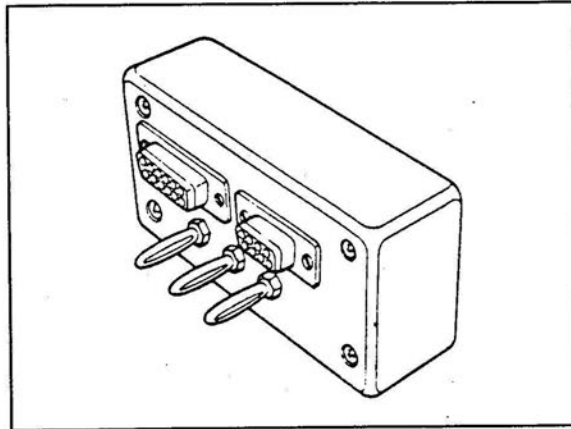

Saab Diagnostic Adapter (SDA) 86 11 188 (old)  
Saab Diagnostic Adapter II 86 11 436 (new)

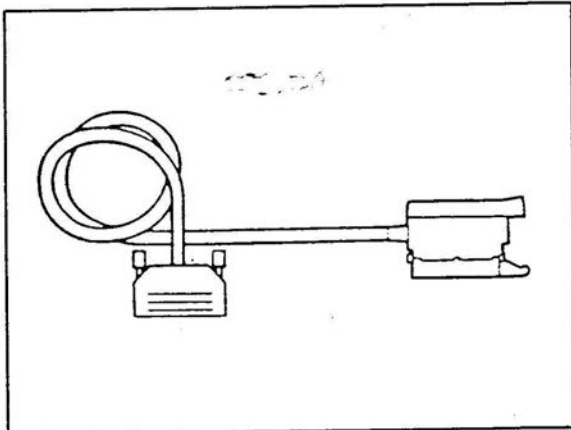

BOB cable (ASR) 86 11 139

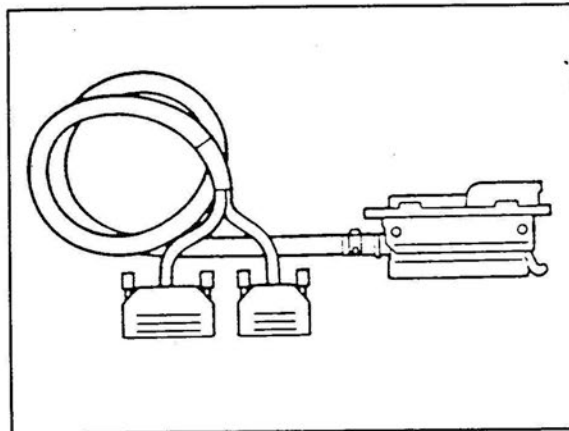

BOB cable (ETS) 86 11 014

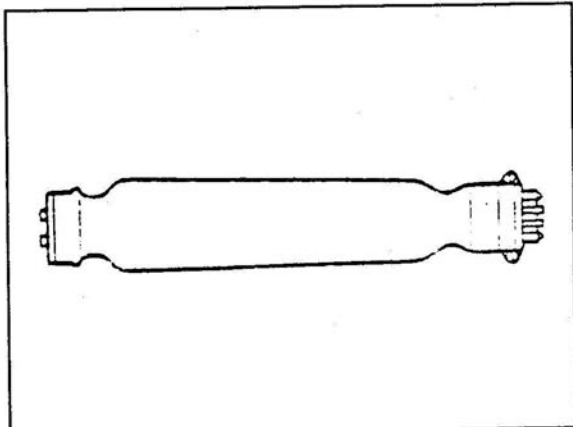

Capacitor cable 86 11 048

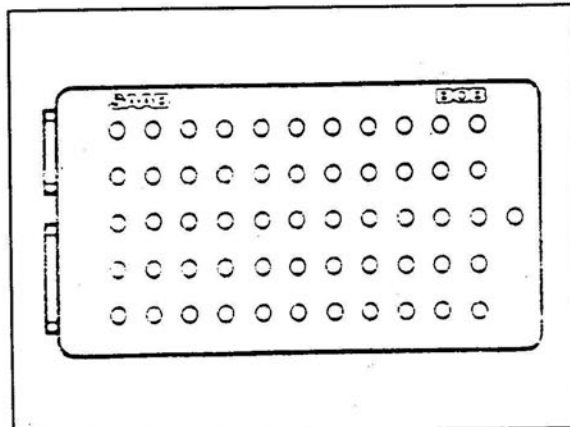

Breakout Box (BOB) 86 11 006

**Saab special tools (contd.)**

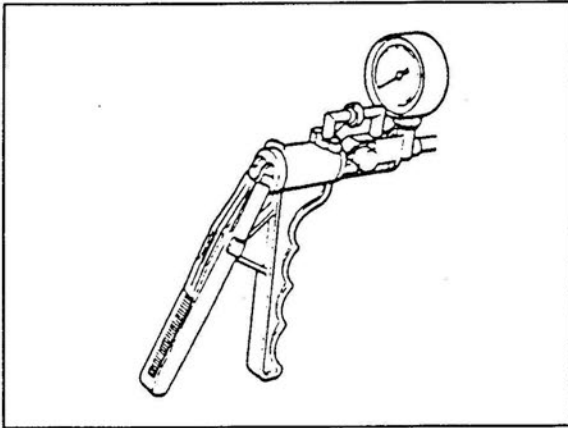

Pressure/vacuum gauge (45)-30 14 883

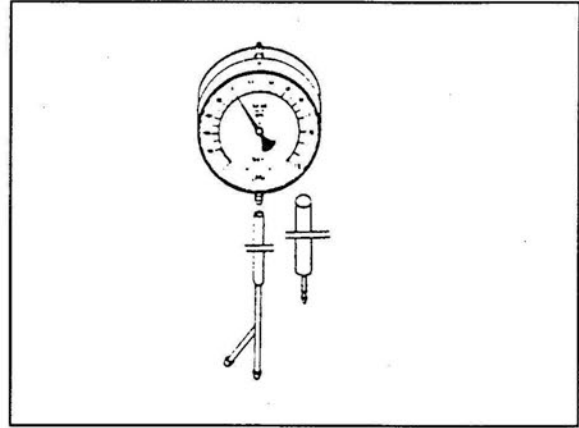

Pressure gauge 83 93 514

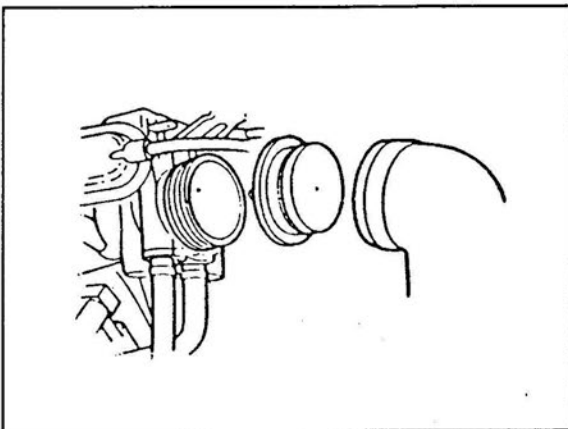

Blanking plug 83 94 587

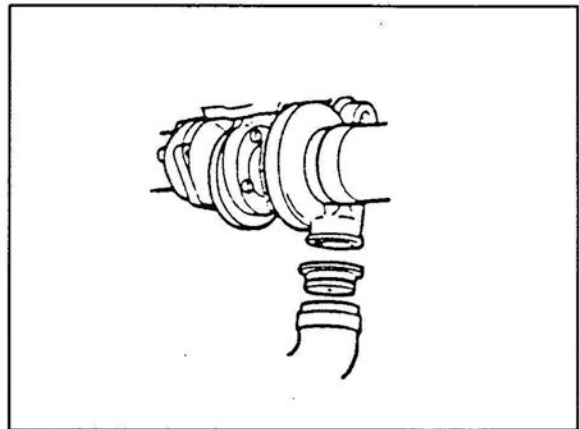

Blanking plug 83 94 595

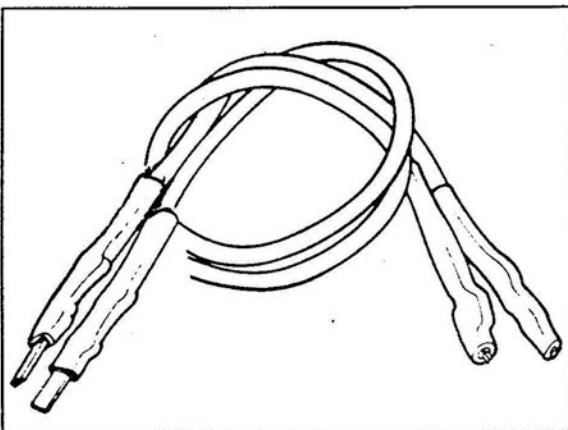

Breakout cable 40 66 916

# Saab Recommended Tools

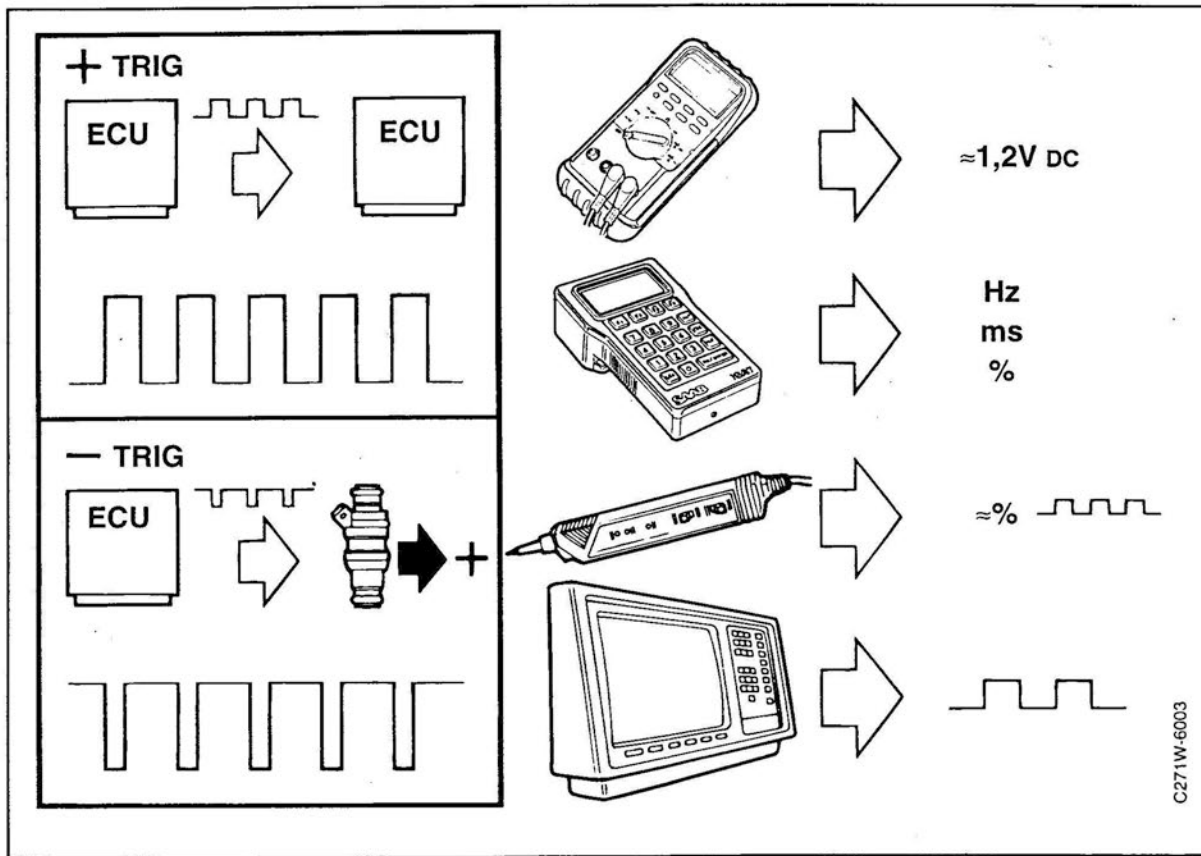

## Quick-reference parts list

Component	Part No.	Part No. of replacement component	Modification/identification (as of chassis No./week)
ETS control module			
M91	4022653	8827149	
M92	4159182	8827909	
M93	4300075	8828097	Modified ETS control module in production as of week 9250 (502 stamped on module connector) (P1025299/9306).
M931/2	4300539	8828378	Modified ETS control module software self-test routine in production as of week 9311 (113 stamped on module connector) (P1030656/9312).
M941/2	4392601	8828386	Gold plated.
M95	4302378	4610721	Gold plated.
ASR control module	4159190	8827974	
M92/93			
TC/ABS control module			
M91	4190492	8827594	Manual
M92	4195293	8827693	Manual
M92	4107363	8827628	Auto
M93	4199626	8828089	Manual
Throttle body			See page 21 for correct throttle body.
2.0	8982001		
2.3	9109075		Redesigned throttle sensor (due to wear problem) in production as of week 9303 (P1025892/w9310).
M93	4197927		
M941/2	9169699		Gold plated.
M941/2	9170705		Gold plated, can replace 9169699.
		8822348*	
Accelerator pedal position (APP) sensor	4015194 (M) 4161238 (A)		Sealed leads in 5-pin APP sensor connector (P1032318/w9315).
M941/2	4301685 (M)		Gold plated.
Kick-down actuator	4161220		Modified KD-actuator (due to retracted pins) in production as of 9304 (043 stamped on metallic part) (P1028966/w9310).
Kick-down bracket	4163317		Reinforced KD-actuator bracket (cable connection) (P1020737/w9250).
C/CLAMP	4163333		

\* 8822348 is a supplementary kit for changing to a throttle body with gold-plated connector contacts. See which throttle body is suitable for the relevant model year, **page 21**.



Component	Part No.	Part No. of replacement component	Modification/identification (as of chassis No./week)
Safety valve	4015202		Screened safety valves as of week 9304 (stamped on valve body) (P1024304/w9305).
Rubber bushing	7973456		
Brake/clutch switch	4350443		
Brake light switch	9505462		
Limp Home cable			Modified (longer) cable fitted, +5 mm LHD, +10 mm RHD, together with throttle body 9170705.
2.3 M91	4022737(LHD)		
2.3 M91	4018313(RHD)		
2.0 M91	8980922(LHD)		
2.3 M94 engine No. 166911-	4526711(RHD)		
Non-return valve	4301669		Red-white body with integrated filter (P1040435/w9323).
Engine coolant temperature sensor	8788200		
ETS Main Relay	8522310		Bosch/Hella
Charge air bypass control valve	4019253		
Charge air bypass valve hose set	4021218		
TCS on/off switch			
M95 man	4439477		
Modified carpet on RHD cars as of P1029694/w9311			See page 47.

## Information codes

### Command codes

#### Important

When driving with a COMMAND CODE entered it is normal for the following to be noted:

- a) Low engine idle speed
- b) No cruise control operation

MANUAL:

- c) No TCS operation
- d) No A/C load compensation
- e) Possible generation of DTCs in other systems

AUTO:

As above + rough shifting.

#### Power-Off test

It has been found that DTCs can be generated on certain models during the system power-off test (performed each time the ignition is switched off) while the scan tool is still connected. On all models it is therefore advisable to terminate scan tool communication **before switching off the ignition.**

Code	Command function	Scan tool display
100	Transfer all DTCs to scan tool.	
101	Transfer 1st DTC + counter.	example: 58351 80255 = 58351 generated 255 times.
102	Transfer 2nd DTC + counter.	
103	Transfer 3rd DTC + counter.	
104	Transfer 4th DTC + counter.	
200	A/C relay status.	
202	Cruise control ON/OFF status.	8B102 = ON 8B002 = OFF
203	Cruise control, SET status.	8B103 = ON 8B003 = OFF
204	Cruise control, RESUME status.	8B104 = ON 8B004 = OFF
205	Brake pedal and clutch pedal position switch status.	8B105 = ON 8B005 = OFF
206	Brake light switch status.	8B106 = ON 8B006 = OFF
207	APP sensor safety switch status.	8B107 = ON 8B007 = OFF
208	TP sensor safety switch status.	8B108 = ON 8B008 = OFF
249	Engine speed (Td).	803500 = 3500 rpm
250	Engine coolant temperature above 50° C shown as >+50° C.	800 -15 = -15° C 800 +20 = +20° C

## Command codes (contd.)

Code	Command function	Scan tool display
279	Throttle angle as %.	example: 80030 = 30%
27A	Accelerator pedal travel as %.	example: 80033 = 33%
280	Vehicle speed (km/h).	80150 = 150 km/h
281	Load signal (Tq) pulse duration in microseconds.	Idling = approx. 25 $\mu$ s Full load = 400–500 $\mu$ s
380	EPROM identification No.	example: 80 01REL02 07:53 04.02.91
382	ETS control module part No. (Saab).	(example: 80 43 00 539)
383	ETS control module serial No. (Hella).	(example: 80 65 23 87)
550	A/C relay activated at 0.2 Hz.	8A550
551	Safety valve activated at 1 Hz.	8A551
552	Control valve activated at 1 Hz.	8A552
553	TCS CTRL lamp activated at 1 Hz.	8A553
800	Terminate Communication.	
900	Clear all DTCs.	NOTE: all systems must be cleared separately.
A09	Pedal pos.	example: 89 008
A0A	Pedal pos (ETS control module 40 22 653).	example: 89 008

## Version codes

**Note**

Control module activation codes must be used after replacing the ETS control module. Failure to do so will result in drivability problems.

**Manual**

Engine → ETS ↓	91 2.0	92 2.0	93 2.0	91 2.3	92 2.3	93 2.3	93 TR2.3	941/2 TR2.3	95 TR2.3
91	976	–	–	977	–	–	–	–	–
92	976	976	–	978	977	–	–	–	–
93	976	976	976	–	979	977	–	–	–
931/2	976	976	976	978	979	977	97C	–	–
941/2	–	–	–	–	–	–	–	977	–
95	–	–	–	–	–	–	–	977	977

**Automatic**

Engine → ETS ↓	92TA	93TA					
92	97A						
93 93 1/2	97B	97A					

**ETS control module identification (external)**

Hella No.	Model year	Saab part No.
5DA 006 072 01	M91	4022653
5DA 006 072 02	M92	4159182
5DA 006 072 03	M93	4300075
5DA 006 072 05	M931/2	4300539
5DA 007 368 00	M941/2	4392601
5DA 007 368 01	M95	4302378

## Software identification – ETS control module

(Obtained using C/code 380)

Model year	Version	Time	Date	Remarks
91	01REL01 01REL02	12:53 07:53	11.05.90 04.02.91	Production release Running change
92	02REL02 02REL03	13:40 14:43	23.04.91 17.02.91	Production release Running change
93	03REL00	08:40	13.03.92	Production release
931/2	05REL04	11:48	18.02.93	Production release
941/2	06REL02	10:03	21.10.93	Production release
95	07REL00	15:01	23.02.94	Production release

## Throttle body versions

Model year	2.0 litre	2.3 litre
All	8982001	
M91 – M92		9109075
M93		8982001 Also suitable for earlier model year cars
M941/2		9169699 Gold plated
M941/2		9170705* Gold plated two-hole lever

\* Can replace 9169699 but not vice versa without changing the limp-home cable. See page 33 for adjustment.

### Important

*Never use connectors having tin-plated contacts together with connectors having gold-plated contacts. Always use gold-gold or tin-tin.*

When a throttle body without gold-plated connector contacts is changed for one with gold-plated connector contacts, a supplementary cabling set, part No. 8822348, will be needed. To change the right pins, see the table below.

## Gold plated connector pins, throttle body

Pin	Function
2	throttle potentiometer +
3	switch +
4	throttle position
5	switch output
6	throttle potentiometer -



## Calibration

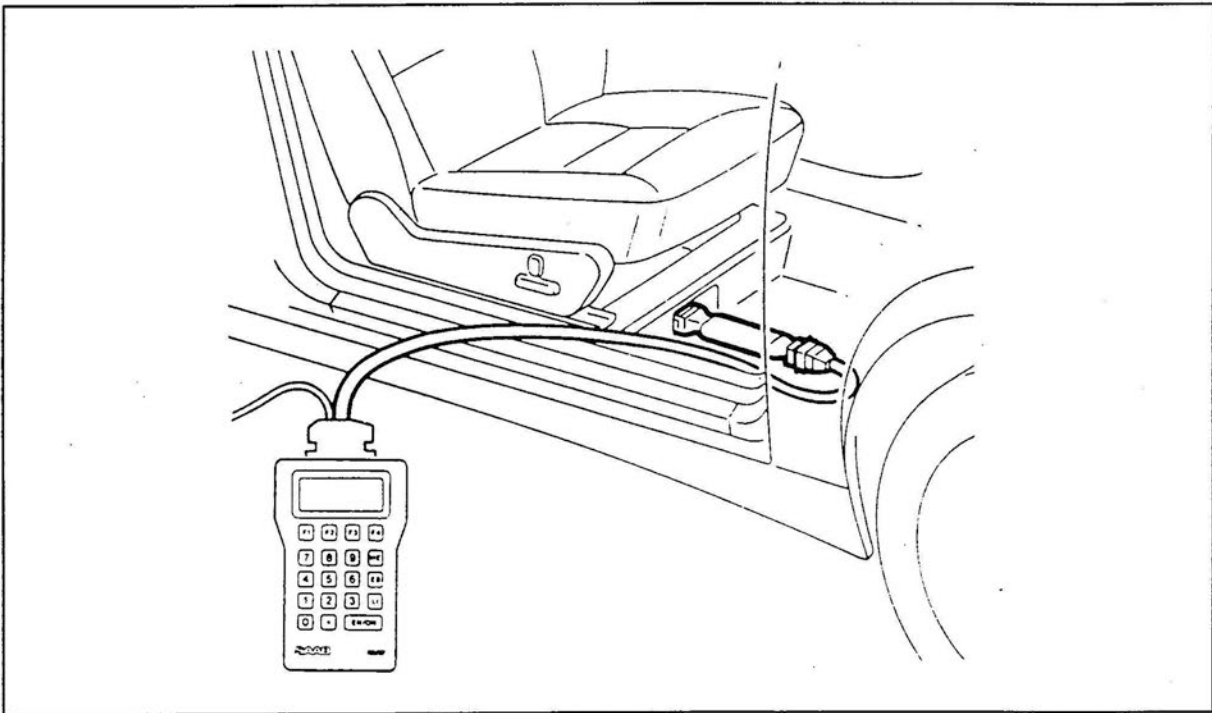

Code	Function	Scan tool display
971	Baseline setting.	8A971 = started 8D971 = finished
973	Calibrates warm engine.	8A973
974	Fast warm-up (pre-cal). Removes adapted control module values.	8A974
975	Displays selected engine version.	See software, e.g. 802.3TM M93 230

### Note

Command Code 974 must be used before replacing the throttle body to prevent internal damage when the ignition is switched on.

## Diagnostic Trouble Codes (DTCs)

### Failure categories

- 1A = TCS CTRL lamp lights up. Limp Home mode. Reset with ignition ► OFF ► ON.
- 1B = TCS CTRL lamp lights up. Limp Home mode. Reset possible only with scan tool.
- 2 = Cruise control and/or ASR and/or gearbox actuator inoperative. No throttle opening during fuel cut-off. TCS CTRL lamp lights up.
- 3 = No cruise control reaction or operation.

DTC	Fault information	Man/Auto	Fail cat	DTC schedule
4/22220	+30 disconnected from ETS control module pin 22 before power-off test completed.		1B	
4/22241	+15 on ETS control module pin 25 higher than 18 V when car is driven (DTC removed as of release 930218).		1A	
4/22252	+15 on ETS control module pin 25 lower than 6 V when car is driven (DTC removed as of release 930218).		3	
4/22320	No +15 detected on ETS control module pin 25 but rpm detected on pin 12.		1B	
4/23691	Kickdown cable pulled excessively or faulty operation of KD actuator motor.	auto	2	
4/23692	Kickdown cable insufficiently pulled or faulty operation of KD actuator motor.	auto	2	
4/24020 4/24021 4/24090	Signals between pins 32 and 29 of the ETC control module and TC/ABS-TC pins 4 and 24 are incorrect.	man	3	81
4/24221	Engine speed signal on ETS control module pin 12 missing but engine load signal on ETS control module pin 27 recognized.		1A	
4/24260	Vehicle speed signal incorrect		3	83
4/24261	Vehicle speed signal or wheel signal missing		3	80

### TCS cars 2.0/2.3 Turbo

On cars having a chassis number between **M1000001** and **M1016012** inclusive, a program error in the control module could erroneously generate the following diagnostic trouble codes

#### 78470/22220

when the cars were driven in cold-weather conditions. This was remedied by changing the control module and then marking box A4 of the modification identity plate.

Therefore, in the case of faults on M91 cars causing these diagnostic trouble codes to occur, always begin by checking the modification identity plate. If a replacement control module has to be fitted, mark box A4 of the modification identity plate with a figure 7.

## Diagnostic Trouble Codes (contd.)

DTC	Fault information	Man/Auto	Fail cat	DTC schedule
4/24262	No wheel speed signals from TC/ABS to the ASR control module.	auto	2	
4/24290	Vehicle speed signal on ETS control module pin 10 incorrect.		3	75
4/24291	Vehicle speed signal or wheel speed sensor signal incorrect. Comparison of vehicle speed signal and TC/ABS speed signal incorrect.	auto man	3 3	75
4/24295	No wheel speed sensor signal at ASR control module	auto	2	
4/24296	ABS control module pin 10 and ASR control module pin 10 (FL).			
4/24297	ABS control module pin 11 and ASR control module pin 9 (FR).			
4/24297	ABS control module pin 12 and ASR control module pin 8 (RL).			
4/24298	ABS control module pin 9 and ASR control module pin 21 (RR).			
4/24390	Engine speed signal disturbance.		3	
4/24391	Engine speed signal incorrect.		1A	
4/24420	Engine load signal on ETS control module pin 27 missing <b>but</b> engine speed signal on ETS control module pin 12 recognized.		3	85
4/24490	Engine load signal disturbance.		3	
4/24690	Comparison of engine load signal and engine speed signal incorrect.		3	87
4/24691	No engine speed signal on ASR control module pin 18 but present on ETC control module pin 12.		3	
4/25240	Voltage at throttle sensor incorrect.		1A	70
4/25241	Voltage at pedal position sensor incorrect.		1A	71
4/25242	Voltage at throttle position sensor incorrect.		1A	70
4/25243	Voltage at pedal sensor incorrect.		1A	71
4/25244	Voltage at KD actuator sensor incorrect.		2	89
4/25245	Voltage at KD actuator sensor incorrect.		2	89
4/25250	Voltage at throttle sensor incorrect.		1A	70

## Diagnostic Trouble Codes (contd.)

DTC	Fault information	Man/Auto	Fail cat	DTC schedule
4/25251	Voltage at pedal sensor incorrect.		1A	72
4/25252	Voltage at throttle sensor incorrect.		1A	70
4/25253	Voltage at pedal sensor incorrect.		1A	71
4/25254	Voltage at KD actuator sensor incorrect.		2	89
4/25255	Voltage at KD actuator sensor incorrect.		2	89
4/25290	Voltage at throttle sensor not constant.		1A	70
4/25291	Voltage at pedal sensor not constant.			71
4/25292	Pedal/throttle signals to ASR control module incorrect.	auto	3	
4/25360	Pedal sensor never reached idle position or pedal sensor incorrect.		2	71
4/25391	After ignition "ON", selector lever in "P" or "N".	auto	3	
4/25720	Throttle position sensor faulty.		1A	73
4/25721	Pedal position sensor faulty.		1A	74
4/25722	Brake/clutch switch signals incorrect.		3	
4/25723	Brake signal from brake light switch but not from TC/ABS.	man	3	
4/25724	Brake signal from TC/ABS but not from brake light switch.	man	3	
4/25770*	Throttle position sensor faulty.		1A	73
4/25771	Pedal position sensor faulty.		1A	74
4/25780	ETS control module faulty.		1A	70
4/25781	Pedal sensor voltages incorrect (removed as of release 930218).		1A	71
4/25791	Mechanical pre-adjustment of kickdown cable (too short).	auto	2	
4/257B1	KD cable not connected or pre-adjustment faulty (too long).	auto	2	
4/257B2	Mechanical pre-adjustment of kickdown cable (too long).	auto	2	

### \* Diagnostic trouble code 4/25770

If DTC 4/25770 is generated in limp-home mode, the throttle body should be changed.

## Diagnostic Trouble Codes (contd.)

DTC	Fault information	Man/Auto	Fail cat	DTC schedule
4/26221	Engine coolant temperature sensor, voltage too high (temp. too low).		3	
4/26271	Engine coolant temperature sensor, voltage too low (temp. too high).		3	
5/33240	Main relay, current too high.		1A	
5/33250	Main relay, current too low.		1A	
5/33270	Ignition "OFF" but main relay "ON".		1B	
5/33440	Safety valve, current too high.		1A	
5/33450	Safety valve, current too low.		1A	
5/33630	Throttle actuator motor, shorting pins 1-7 or one pin to ground.		1A	
5/35780	Voltage at throttle sensor incorrect.		1A	70
5/35781	Voltage at pedal sensor incorrect.		1A	71
5/38341	Constant low idle, ETS control module cannot maintain idling speed at 850 rpm.		3	
5/38351*	Constant high idle, ETS control module cannot maintain idling speed at 850 rpm.		3	
6/72490	ETS control module faulty.		1A	
6/77190	ETS control module faulty.		1A	
6/77191	ETS control module faulty.		1A	
6/77192	ETS control module faulty.		3	
6/77193	ETS control module faulty.		1A	
6/77196	ETS control module faulty.		1A	
6/77290	ETS control module faulty.		1A	
6/772B1	ASR control module faulty.	auto	2	
6/77390	ETS control module faulty.		3	
6/77391	ETS control module faulty or glitches in speed signal.		3	
6/77590	ETS control module faulty.		1A	
6/77592	ETS control module faulty.		1B	

**\* Diagnostic trouble code 5/38351, idling speed too high**

A crankcase ventilation nipple with a larger flow (grey nipple) was introduced in model year 1992. On cars fitted with a B234 engine and the Trionic engine management system, the larger flow could be the cause of excessively high idling speed and the generation of diagnostic trouble code 5/38351 in the ETS.

**Action**

Check the intake system for leakage. If no leakage can be detected, fit a new throttle body, part No. 898200, with date code 083 or later.

## Diagnostic Trouble Codes (contd.)

DTC	Fault information	Man/Auto	Fail cat	DTC schedule
6/77593	Voltage at pedal or throttle sensor incorrect.		1A	
6/77594	Voltage at pedal or throttle sensor incorrect.		1A	
6/77595	Voltage at pedal or throttle sensor incorrect.		1A	
6/775B0	System has not been calibrated correctly when warm (973).		3	
6/775B1	3000 rpm cannot be attained during calibration.		2	70
6/775B2	No engine version selected.		2	
6/775B3	ASR control module faulty.	auto	3	
6/775B4	ASR control module faulty.	auto	3	
6/775B5	ASR control module faulty.	auto	3	
6/78170	ETS control module faulty.		1B	
6/78331	KD actuator/DC motor, shorting pins 1 to 7 or one pin to ground.	auto	2	
6/78340	ETS control module faulty.		1B	
6/78341	ETS control module faulty.		1A	
6/78342	ETS control module faulty (removed as of release 930218).		3	
6/78380	ETS cannot maintain correct throttle position.		1A	91
6/78391	ETS control module faulty.		1A	
6/783B0	Oscillating throttle sensor signal.		1A	90
6/783B1	Limp-home position of KD actuator faulty.	auto	3	
E/D7590*	Pneumatic system or throttle sensor faulty.		1B	77
E/D7591*	ETS cannot open throttle to requested position.		3	79
E/D75B1 E/D75B2 E/D75B3	Signals between ETS control module pins 32 and 29 and ASR control module pins 2 and 14 incorrect.	auto	2	

\* On detection of these codes, see also page 250 of Service Manual 2:5.

## Diagnostic procedures

### Component identification and testing

Throttle body .....	31	Non-return valve .....	43
Kickdown actuator .....	35	ASR control module .....	44
Control valve .....	38	Pedal position sensor .....	45
Safety valve .....	40	Fault diagnosis/replacement of diodes in	
ETS control module .....	42	ABS-TC/ABS-system .....	48

### Throttle body

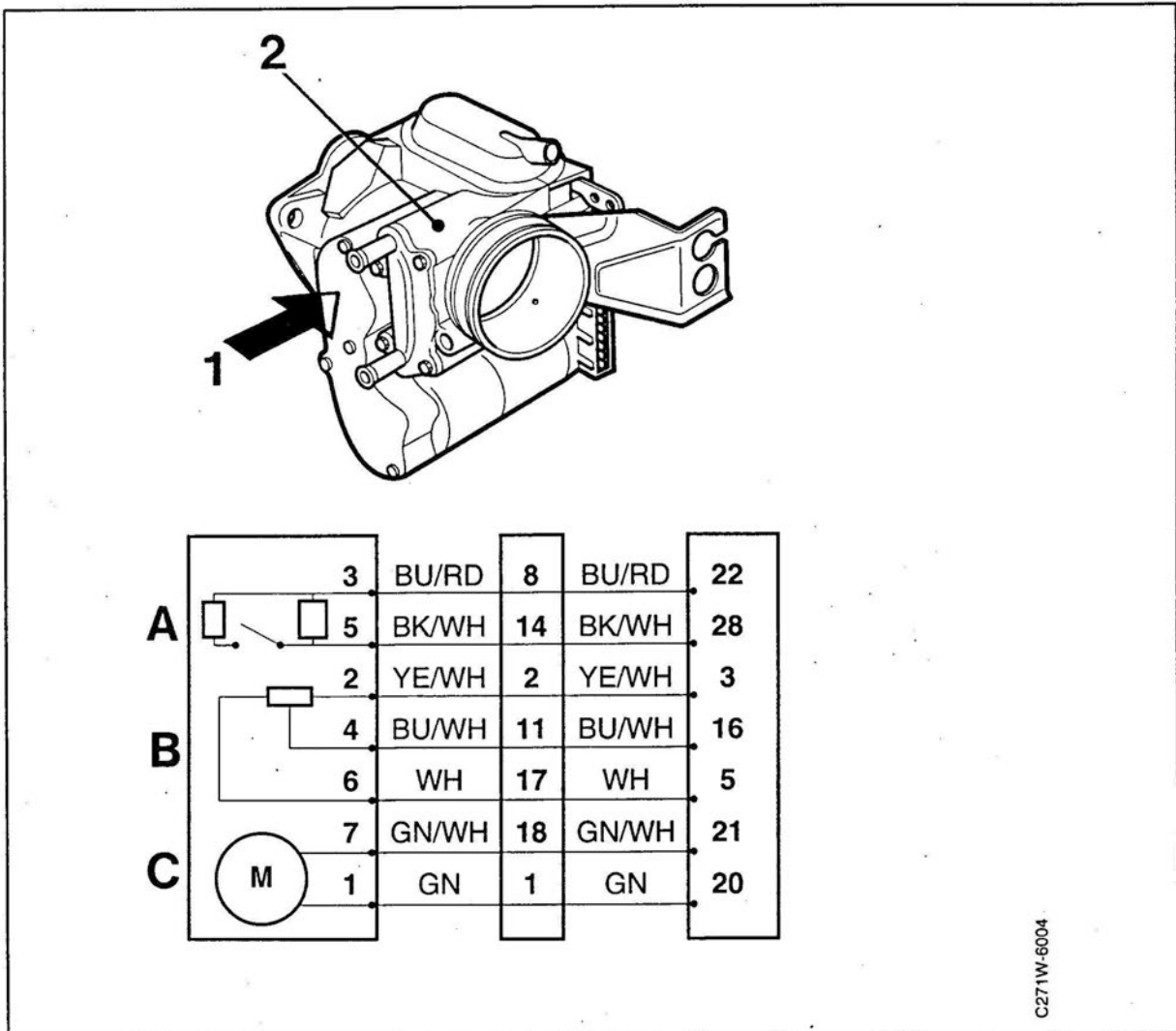

A. Safety switch  
 B. Potentiometer  
 C. DC motor

1. ID No. (eg. 373)  
 2. Alternative ID No. (eg. 142371)  
 3. Throttle body  
 4. H24-1 connector  
 5. ETS control module  
 Code 054 means manufactured week 05, 1994.



## Throttle safety switch test

- 1 Detach limp home cable from the lever.
- 2 Plug in the BOB and connect a multimeter to pin 16 (potentiometer) and pin 1 (main ground). Make sure that the multimeter is set for measuring voltage.
- 3 Switch the ignition ON.
- 4 Use scan tool command code 208 to monitor the safety switch.
- 5 Depress the accelerator more than halfway to the floor. Repeat at least 5 times. The safety switch should not be activated (scan tool display).
- 6 Note the voltage reading when the accelerator is more than halfway to the floor.
- 7 Release the pedal and exhaust the vacuum unit in the throttle body.
- 8 Depress the accelerator slowly until the safety switch actuates and is ON (scan tool display).
- 9 Keep the pedal at this position and read out the voltage again.
- 10 The voltage should be between 2.94 V and 3.56 V but lower than the first voltage obtained.

### Note

Depressing the accelerator causes the throttle potentiometer voltage to decrease (highest voltage in the idle position and lowest voltage at full throttle).

### Note

Command Code 974 must be used before the throttle body is replaced to prevent internal damage when the ignition switch is turned ON.

### Attention

Before switching the ignition OFF, make sure that the vacuum unit is exhausted again. If this is not done, the DTC "E (D) 7590" will be displayed.

Switch ON=8B108



## Throttle Safety Switch

### Bench Test

To test the safety switch in the throttle body

- 1 Switch the ignition OFF.
- 2 **Unplug the electrical connectors on the throttle.**

#### Note

All Pin numbers refer to the connector on the throttle body.

- |   |                 |   |
|---|-----------------|---|
| 3 | Pins 3 and 5    | $R = 24\text{ k}\Omega - 30\text{ k}\Omega$   |
|   | closed throttle | $R = 440\text{ k}\Omega - 540\text{ k}\Omega$ |
|   | half throttle   | $R = 0.8\text{ k}\Omega - 1.2\text{ k}\Omega$ |
| 4 | Pins 2 and 6    |   |
| 5 | Pins 2 and 4    |   |
|   | closed throttle | $R \leq 100\ \Omega$                          |
|   | open throttle   | $R \geq 750\ \Omega$                          |
| 6 | Pins 3 and 4    | $R \geq 1\text{ M}\Omega\text{ (O.L.)}$       |
|   | Pins 3 and 6    | $R \geq 1\text{ M}\Omega\text{ (O.L.)}$       |
|   | Pins 3 and 2    | $R \geq 1\text{ M}\Omega\text{ (O.L.)}$       |
|   | Pins 5 and 4    | $R \geq 1\text{ M}\Omega\text{ (O.L.)}$       |
|   | Pins 5 and 6    | $R \geq 1\text{ M}\Omega\text{ (O.L.)}$       |
| 7 | Crosschecks:    |   |

Pin 7 — throttle body (aluminium)  
 $R \geq 1\text{ M}\Omega\text{ (O.L.)}$

Pin 8 — throttle body (aluminium)  
 $R \geq 1\text{ M}\Omega\text{ (O.L.)}$

#### Note

It is possible to turn the connector housing through a maximum of  $11^\circ$ . This is perfectly normal.

#### Note

Command Code 974 must be used before the throttle body is replaced to prevent internal damage when the ignition switch is turned ON.

#### Note

Before switching the ignition ON, make sure that all components and connectors are correctly fitted and plugged in.

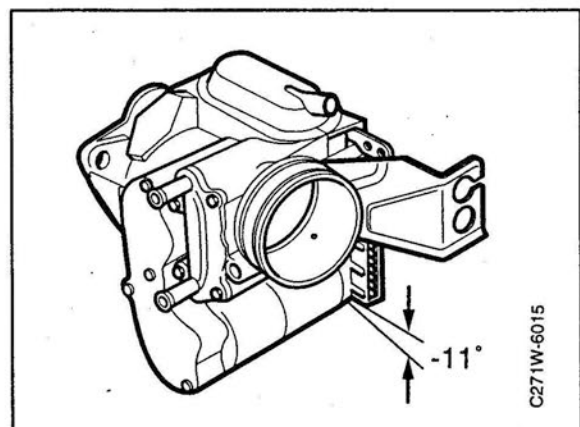
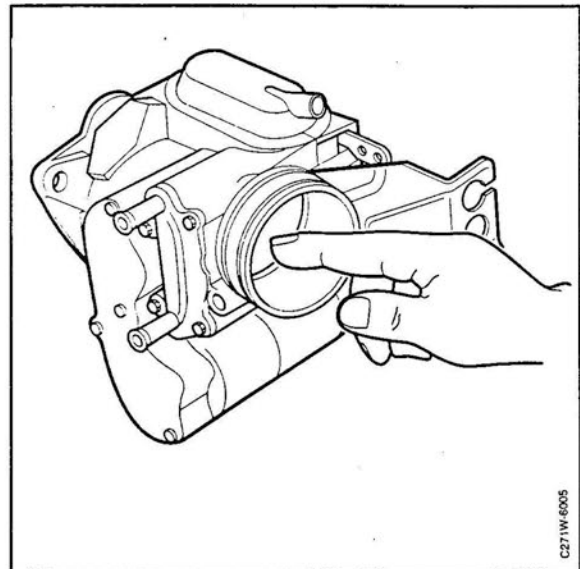

## Throttle body

### Torque test

Perform the torque test only if DTC 7/68390 is generated.

- 1 Switch the ignition OFF.
- 2 Unplug the electrical connectors on the throttle.
- 3 Disconnect the large rubber hose attached to the throttle air inlet (so that the throttle butterfly can be moved by hand).
- 4 Exhaust the vacuum unit so that it moves to its maximum position.
- 5 Pinch the hose and move the throttle butterfly to the idle position by hand.
- 6 Apply a voltage to pins 1 and 7 as shown (the DC motor will then close the butterfly).
- 7 Now move the butterfly slowly to the open position.
- 8 Watch the lamp to see whether it varies widely in brightness (if it does, replace the throttle body).

#### Note

Command Code 974 must be used before the throttle body is replaced to prevent internal damage when the ignition switch is turned ON.

#### Note

Before switching the ignition ON, make sure that all components and connectors are correctly fitted and plugged in.

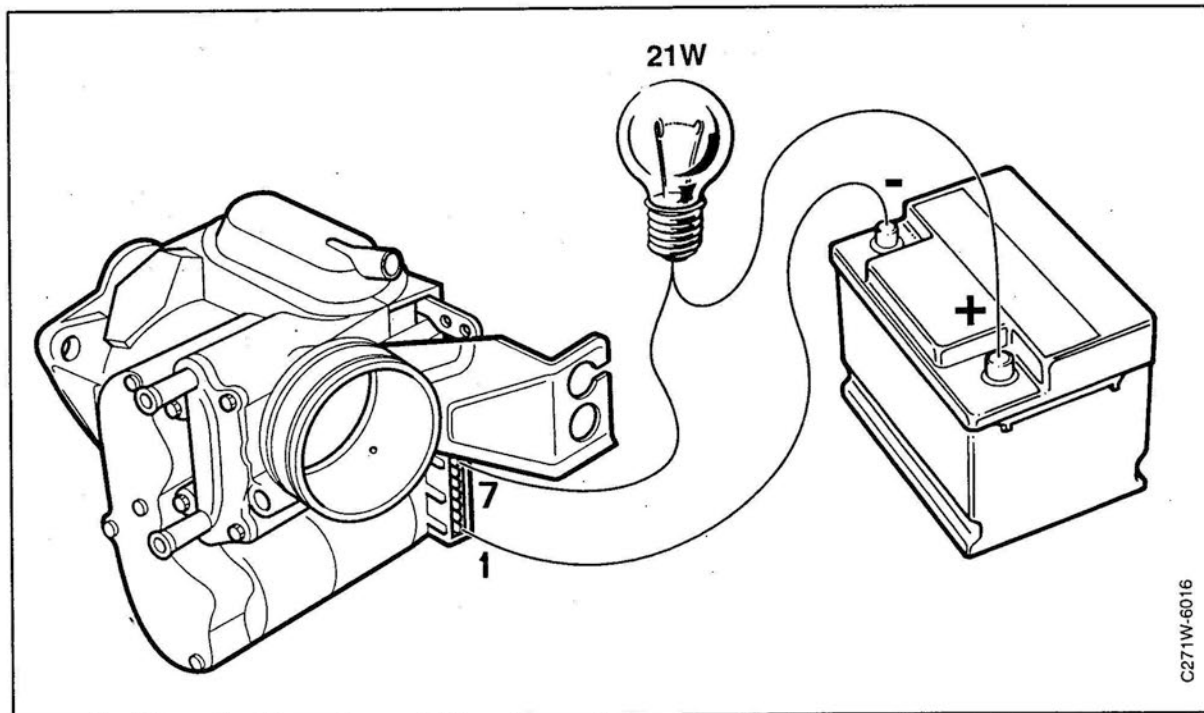

## Throttle body

### Mechanical operation

#### 1 Leakage in vacuum unit

Exhaust the vacuum unit until it is in the halfway position and check for leakage.

#### 2 High friction on throttle shaft

Exhaust the vacuum unit.

Only slight force should be needed to turn the throttle butterfly by hand through its complete range of movement (a squeaking noise might be heard from the DC motor while doing this but it is perfectly normal and no cause for alarm).

#### 3 Return springs

Open the throttle butterfly to the maximum idle angle and apply 12 volts to the DC motor (positive to pin 1, negative to pin 7). The DC motor should not be able to open the flap any further. (Apply 12 V to the motor for a few seconds only.)

#### 4 Limp-home cable lever jammed/stiff

Spray Kontakt 61 through the lever opening in the black plastic cover to lubricate the mechanism inside. Check the operation of the mechanism by starting and switching off the engine, following which the lever should return to its fully retracted position.

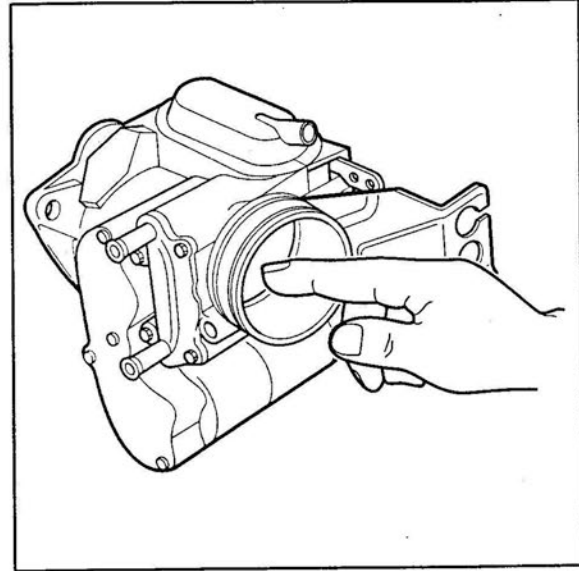

### Procedure for checking the cable slack, -M94 1/2

#### Idle position

- 1 Switch the ignition OFF.
- 2 Check whether there is a minimum slack of about 1 mm in the cable.

#### Full throttle position

- 1 Switch the ignition OFF.
- 2 Disconnect from the safety valve the rubber hose running between it and the throttle vacuum unit.
- 3 Exhaust the vacuum unit to its maximum position and pinch off the hose.
- 4 Press the accelerator all the way to the floor.
- 5 Check whether there is a minimum of about 1 mm slack in the cable. If there is not, check the mechanical linkage and if this is OK change the limp home cable.
- 6 Before switching the ignition ON, make sure that all components and connectors are correctly fitted and plugged in.

## Procedure for checking the cable slack, M94 1/2-

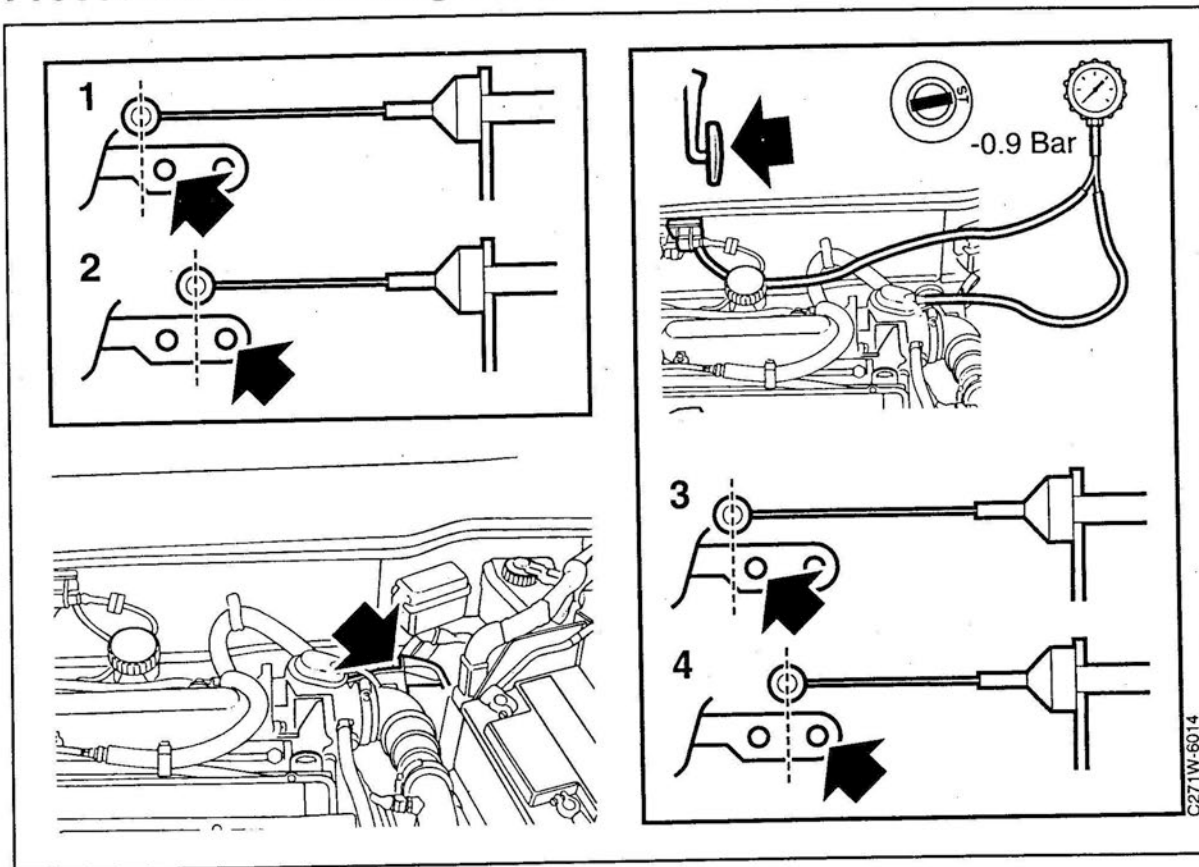

### Idle position

- 1 Pull the cable to tension it. Note which hole is the most suitable, as shown (in this case the inner hole).
- 2 If the cable nipple comes between the holes, use the outer hole.

### Full throttle position

- 3 Build up a vacuum of  $-0.9$  bar in the throttle body's vacuum unit. Depress the accelerator. Note the position of the cable nipple (in this case the inner hole).
- 4 If the cable nipple comes between the holes, use the outer hole.

If the outer hole has been selected in **either** of the tests, use the outer hole.

If the inner hole has been selected in **both** of the tests, use the inner hole.

### Important

If the cable nipple comes outside the outer hole in any test, adjustment of the cable or its attachment will be necessary.

## Throttle body

### In-car component testing

- 1 If DTC 4/25770 or 4/25720 has been generated, carry out the Throttle Safety Switch test first.
- 2 Switch the ignition OFF.
- 3 Wait 20 seconds.
- 4 Connect a BOB and unplug the ETS and ASR control modules (aut only).
- 5 Take resistance readings between individual pins. All pin numbers refer to the BOB.
- 6 Pins 22 and 28

Closed throttle	$R = 24\text{ k}\Omega - 30\text{ k}\Omega$
Half throttle	$R = 440\ \Omega - 540\ \Omega$
- 7 Pins 3 and 5  $R = 800\ \Omega - 1200\ \Omega$   
all positions
- 8 Pins 3 and 16

Closed throttle	$R \leq 100\ \Omega$
Open throttle	$R \geq 750\ \Omega$
- 9 Pins 22 and 16  $R \geq 1\text{ M}\Omega$  (O.L.)  
Pins 22 and 5  $R \geq 1\text{ M}\Omega$  (O.L.)  
Pins 22 and 3  $R \geq 1\text{ M}\Omega$  (O.L.)  
Pins 28 and 16  $R \geq 1\text{ M}\Omega$  (O.L.)  
Pins 28 and 5  $R \geq 1\text{ M}\Omega$  (O.L.)  
Pins 28 and 3  $R \geq 1\text{ M}\Omega$  (O.L.)

**Note**

Before switching the ignition ON, make sure that all components and connectors are correctly fitted and plugged in.

# Kick Down Actuator

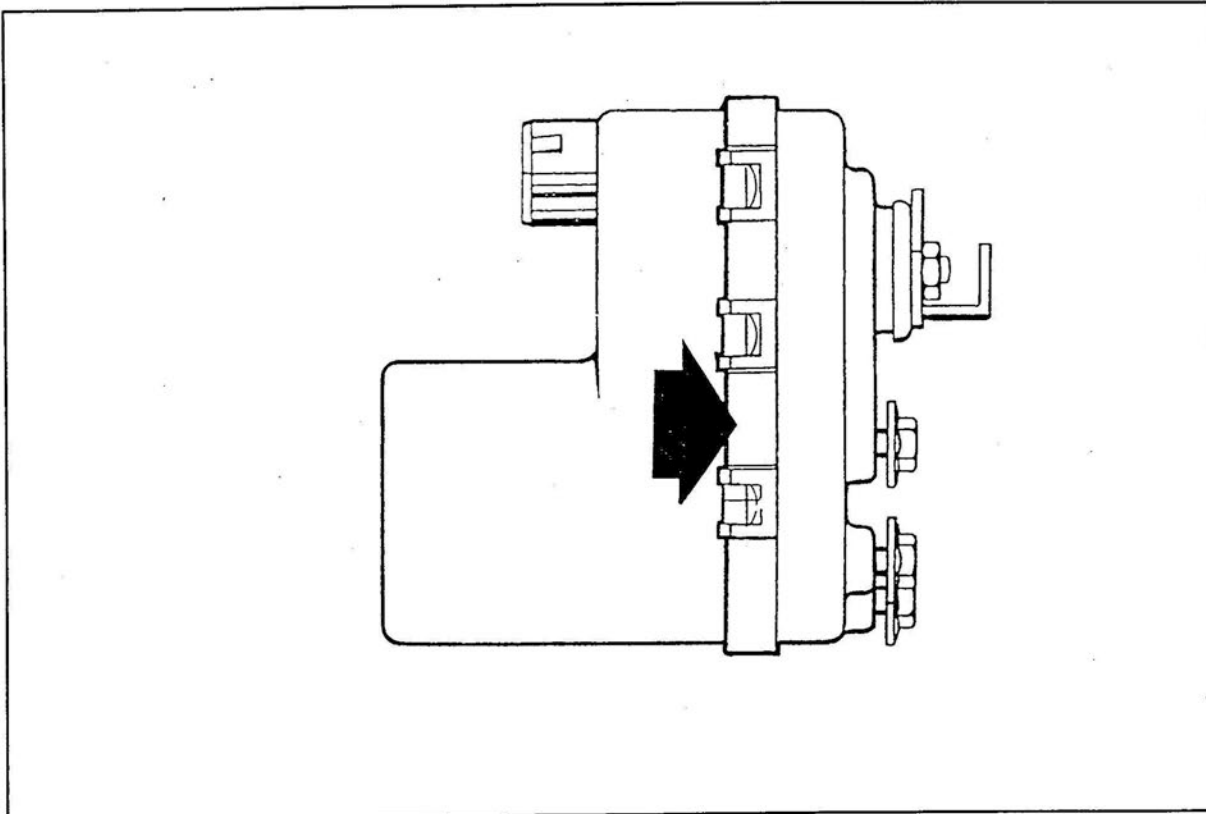

Identification No. (e.g. 043)

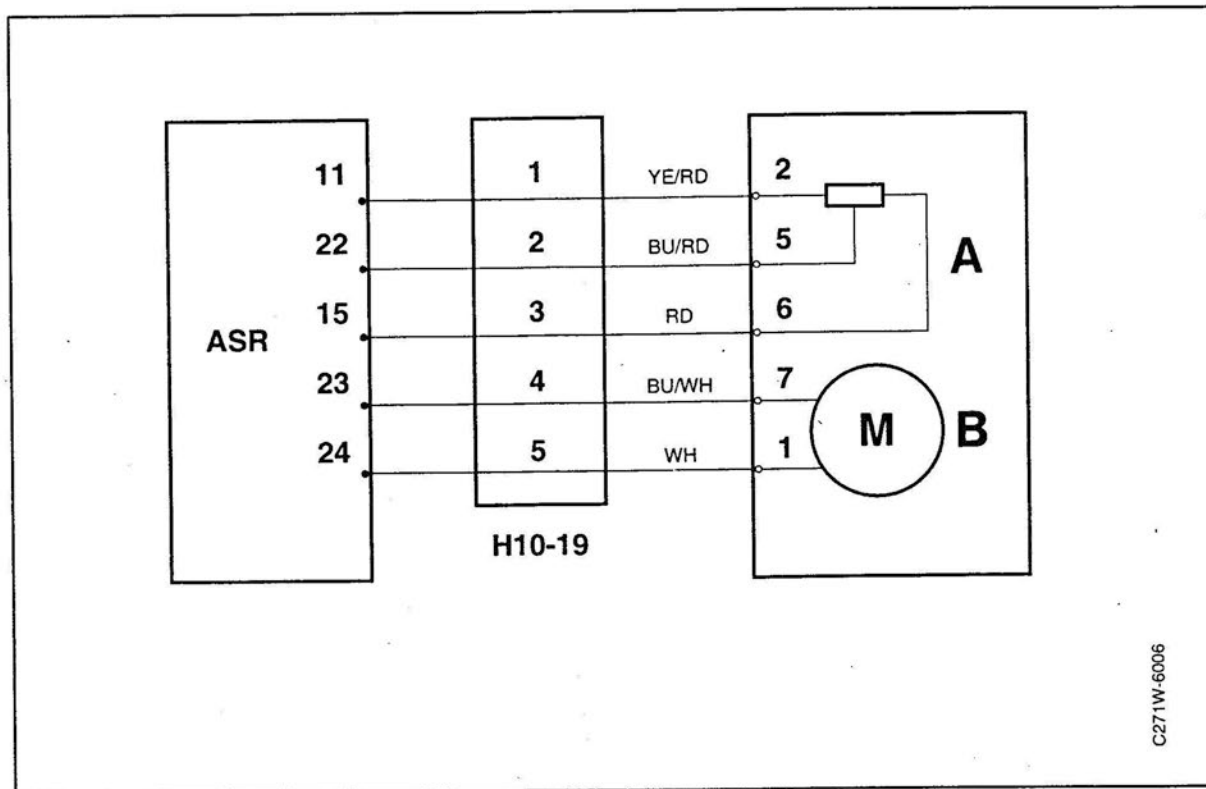

ASR control module

KD actuator

C271W-6006

- A. Potentiometer
- B. DC motor

## Kick Down Actuator

### Bench Test

Switch the ignition OFF.  
Wait 20 sec.  
Disconnect the kick-down actuator completely.

#### Return spring

Rotate the lever against the force of the inner spring. A constant force should be felt moving the lever in the full throttle direction.

#### Potentiometer

Use an ohmmeter to check the following:  
Pin 2---6  $R = 800 - 1200 \Omega$   
Pin 2---5  $> 750 \Omega$  (released position)  
Pin 2---5  $< 120 \Omega$  (rotated position)

#### Crosscheck, KD actuator winding.

Pin 7 – metallic housing  $R \geq 1 \text{ M } \Omega$  (OL)  
Pin 1 – metallic housing  $R \geq 1 \text{ M } \Omega$  (OL)

#### Torque test KD-actuator

##### Note

Perform the torque test only if DTC 2/43691 or 2/43692 has been generated.  
Apply battery voltage to pins 1 and 7, as shown (the lever should move to the idle position).  
Move the lever slowly against the force of the DC motor in the wide open throttle direction.  
Watch the lamp. If it varies widely in brightness, the KD actuator is faulty and must be replaced.

##### Note

Before switching the ignition ON, make sure that all components and connectors are correctly fitted and plugged in.

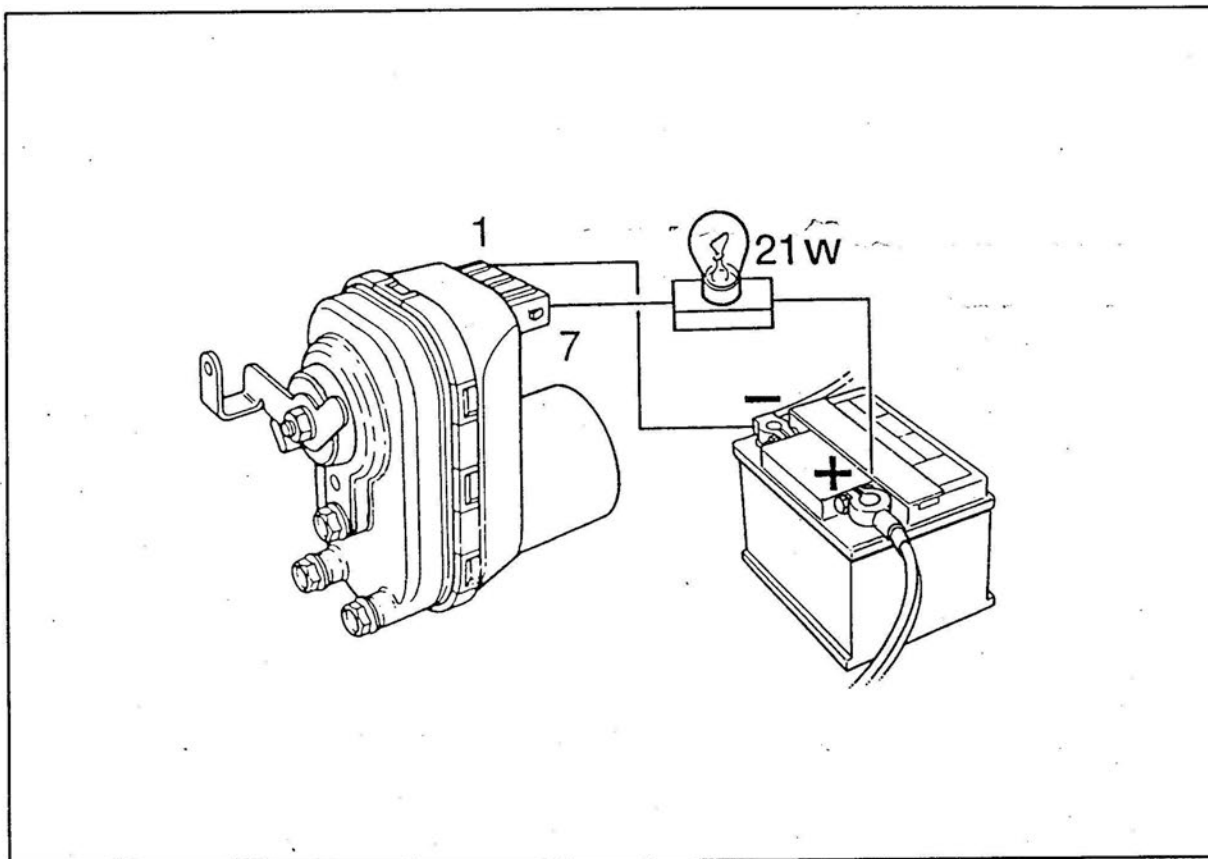

## Kick Down Actuator

### In-car component testing

- 1 Switch the ignition OFF.
- 2 Wait 20 seconds.
- 3 Plug in a BOB but leave the ETS and ASR control modules disconnected.
- 4 Take resistance readings between individual pins on the ASR control module.

All pin numbers refer to the BOB.

Pins 11 and 15  $R = 800 - 1200 \Omega$

Pins 11 and 22  $R = > 750 \Omega$  (cable disconnected – lever against stop above full throttle position)

Pins 11 and 22  $R = < 120 \Omega$  (cable disconnected – lever against stop below idle position)

#### Note

Before switching the ignition ON, make sure that all components and connectors are correctly fitted and plugged in.



## Charge Air Bypass Control Valve

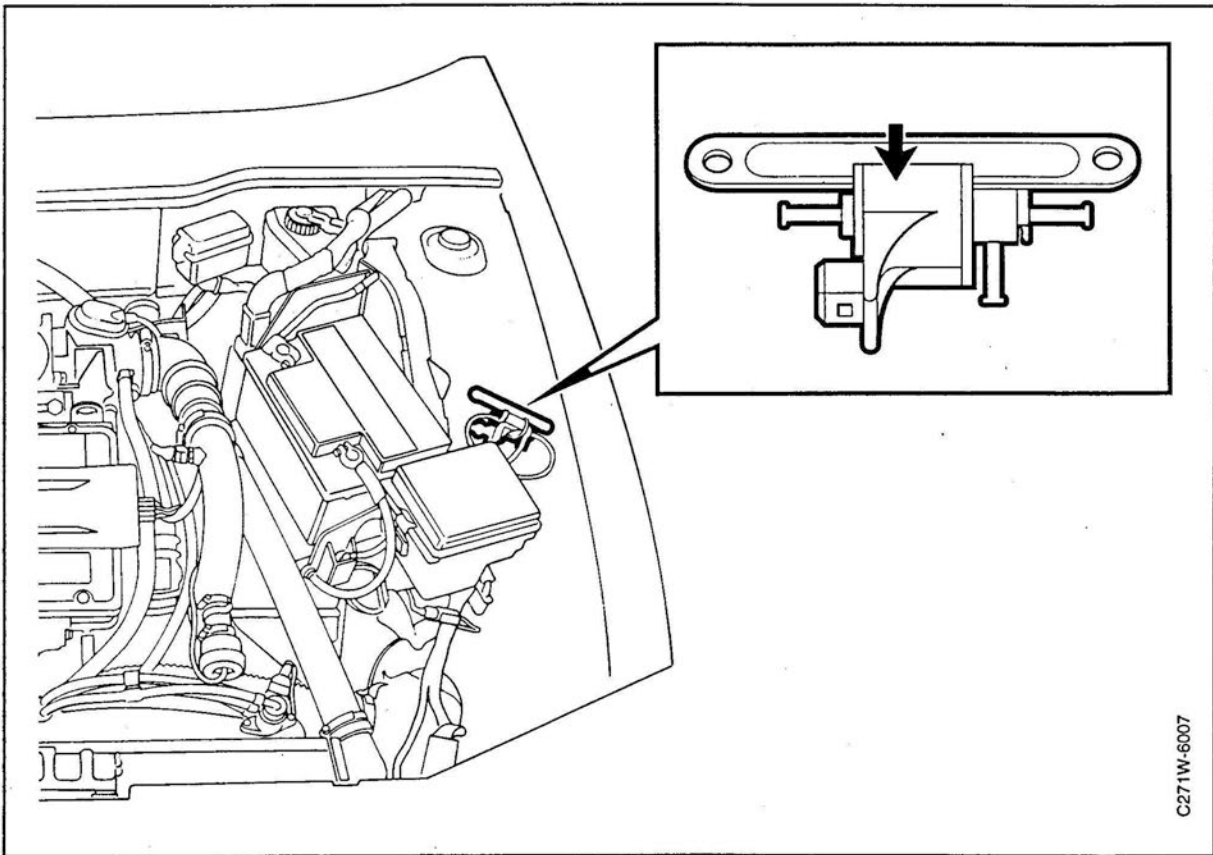

C271W-6007

Identification No. (e.g. 9304)

### Test

Check the resistance

Pins 1 and 2 :  $R \approx 30 \Omega$

#### Note

Before switching the ignition ON, make sure that all components and connectors are correctly fitted and plugged in.

## Charge air bypass control valve

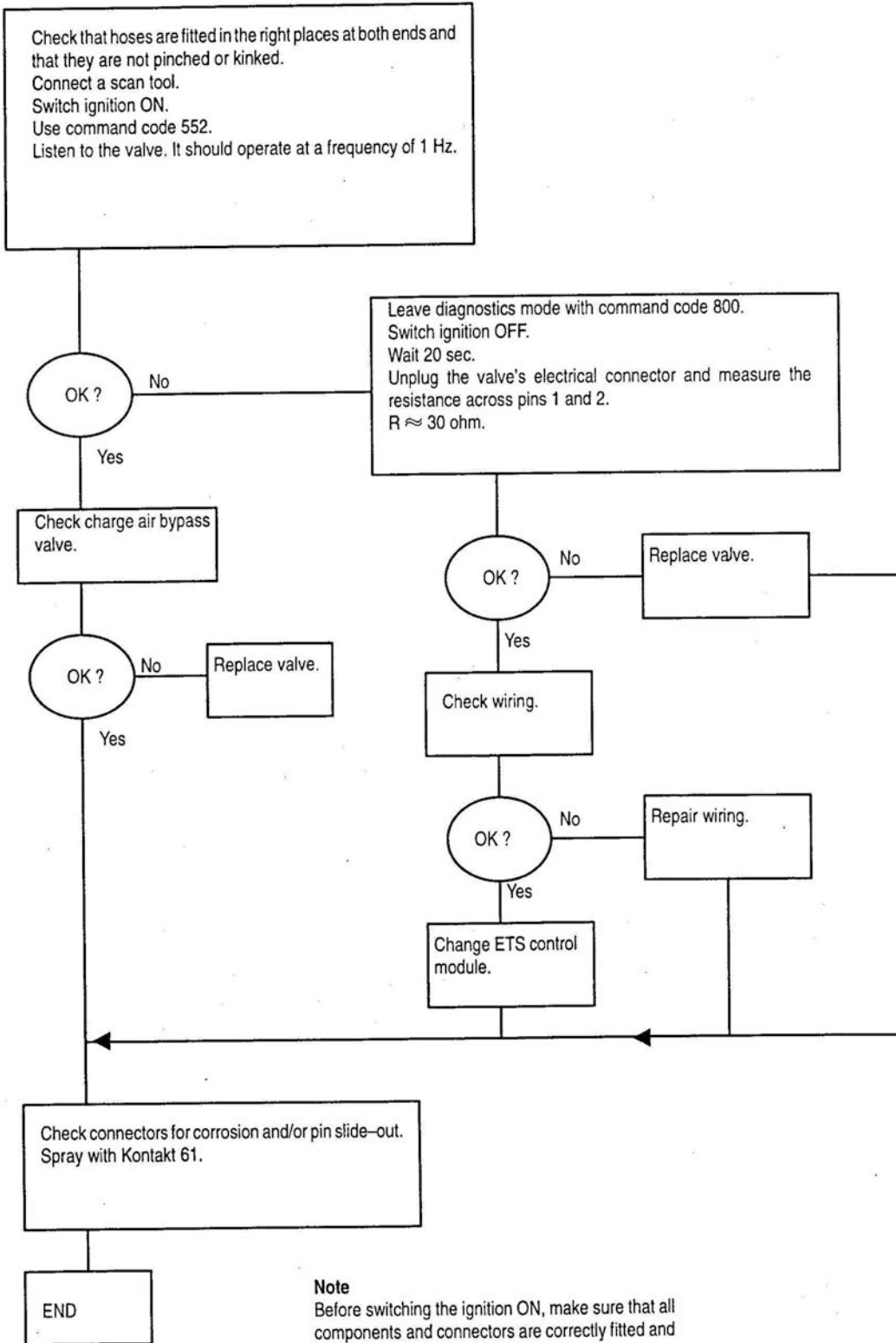

**Note**  
Before switching the ignition ON, make sure that all components and connectors are correctly fitted and plugged in.

## Safety Valve

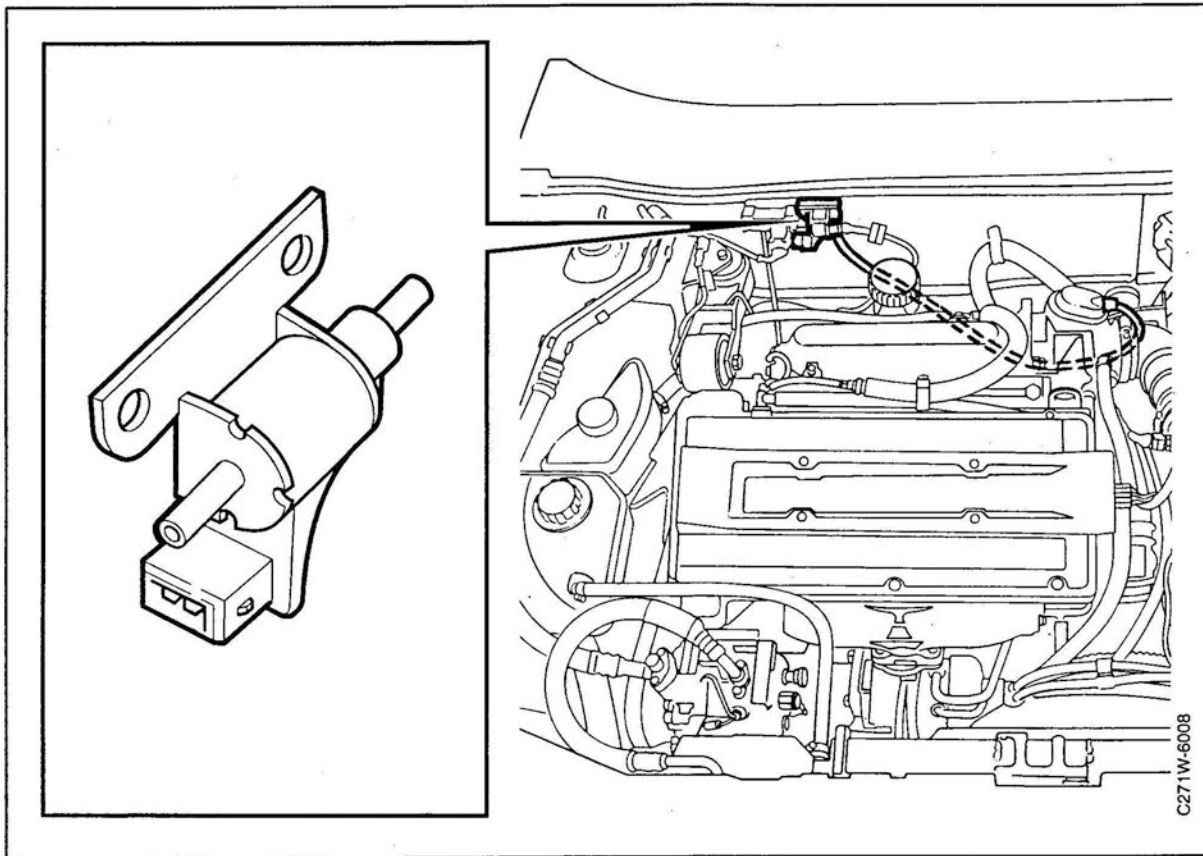

### Bench Test

Check resistance  
Pins 1 and 2 :  $R \approx 30$  ohms

### Note

Before switching the ignition ON, make sure that all components and connectors are correctly fitted and plugged in.

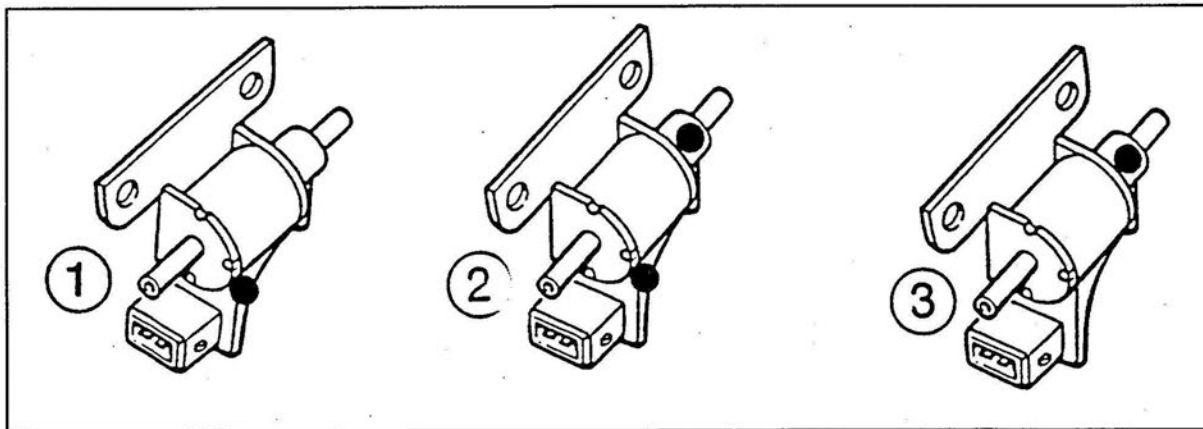

### Different markings on safety valves

Different markings may occur on safety valves as a result of improvements that are introduced from time to time, see Fig. Safety valves may be of 1st, 2nd or 3rd generation type (code 9304 or later), see Fig.

## Safety valve

### In-car component test

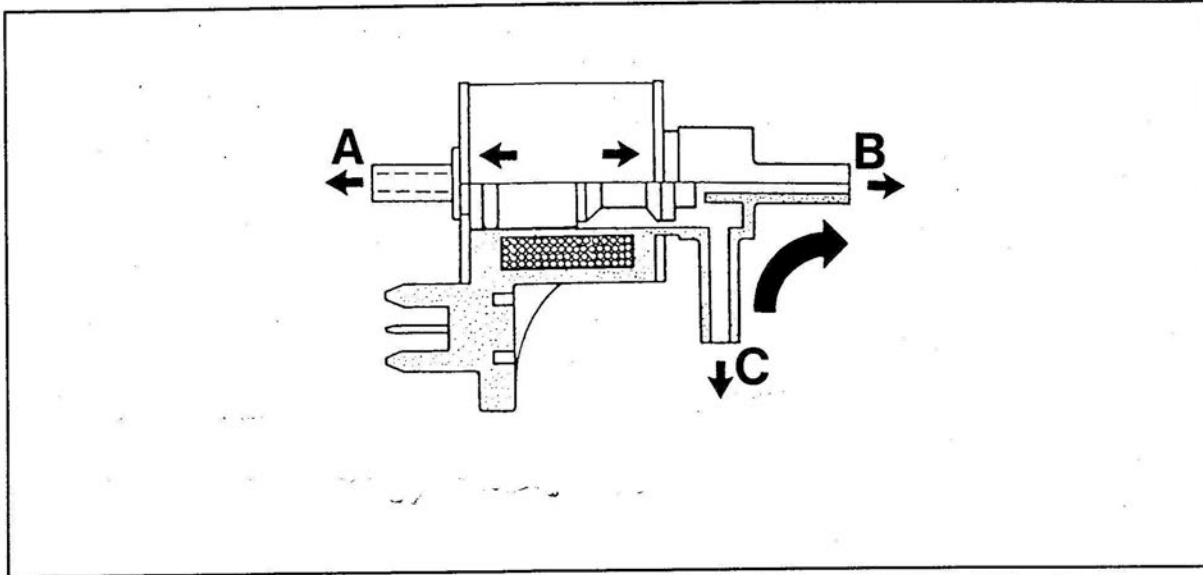

A Barometric pressure, short hose      B Non-return valve → intake manifold      C Throttle body

- 1 Switch the ignition OFF.
- 2 Plug in a scan tool and switch the ignition ON.
- 3 Contact system No. 3.
- 4 Enter command code 551.
- 5 Listen to the safety valve. It should operate at a frequency of 1 Hz.
- 6 Leave diagnostics mode with code 800.

#### Note

Check that air can pass between point B and point C but not between point A and point C.

- 7 Switch the ignition OFF.

#### Note

Check that air can pass between point A and point C but not between point B and point C.

#### Hint for checking leakage

Start the engine. Pinch the hose between the intake manifold and the non-return valve.

Check for leakage with a vacuum meter at point B. There must be a negative pressure of  $\approx 0.6$  bar.

Before switching the ignition ON, make sure that all components and connectors are correctly fitted and plugged in.

## ETS control module

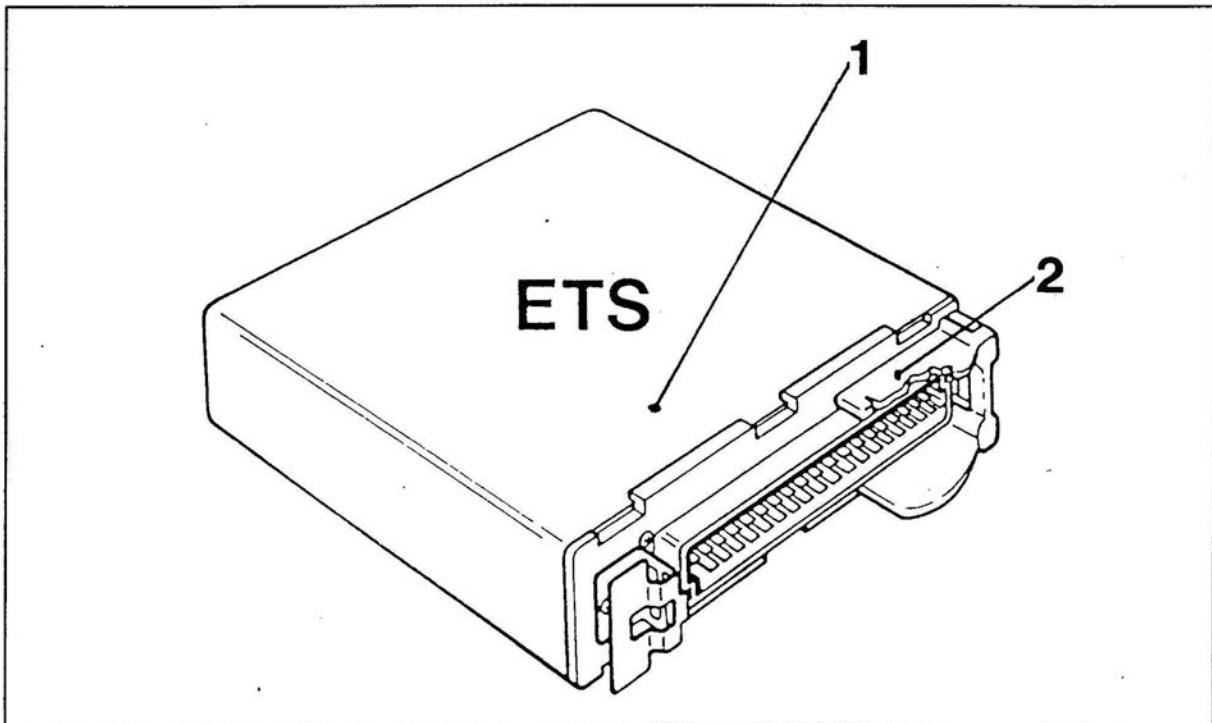

1 Hella No. (e.g. 5DA00607205)

2 Date code (e.g. 113)

### ETS control module identification (external)

Hella No.	Model year	Saab part No.
5DA 006 072 01	M91	4022653
5DA 006 072 02	M92	4159182
5DA 006 072 03	M93	4300075
5DA 006 072 05	M931/2	4300539
5DA 007 368 00	M941/2	4392601
5DA 007 368 01	M95	4302378

### Software identification, ETS control module\*

Barometric pressure, short hose

(Obtained using C/code 380)

Model year	Version	Time	Date	Remarks
91	01REL01	12:53	11.05.90	Production release
	01REL02	07:53	04.02.91	Running change
92	02REL02	13:40	23.04.91	Production release
	02REL03	14:43	17.02.92	Running change
93	03REL00	08:40	13.03.92	Production release
931/2	05REL04	11:48	18.02.93	Production release
941/2	06REL02	10:03	21.10.93	Production release
95	07REL00	15:01	23.02.94	Production release

\* See page 44 for updating of ASR.

## Non-return valve

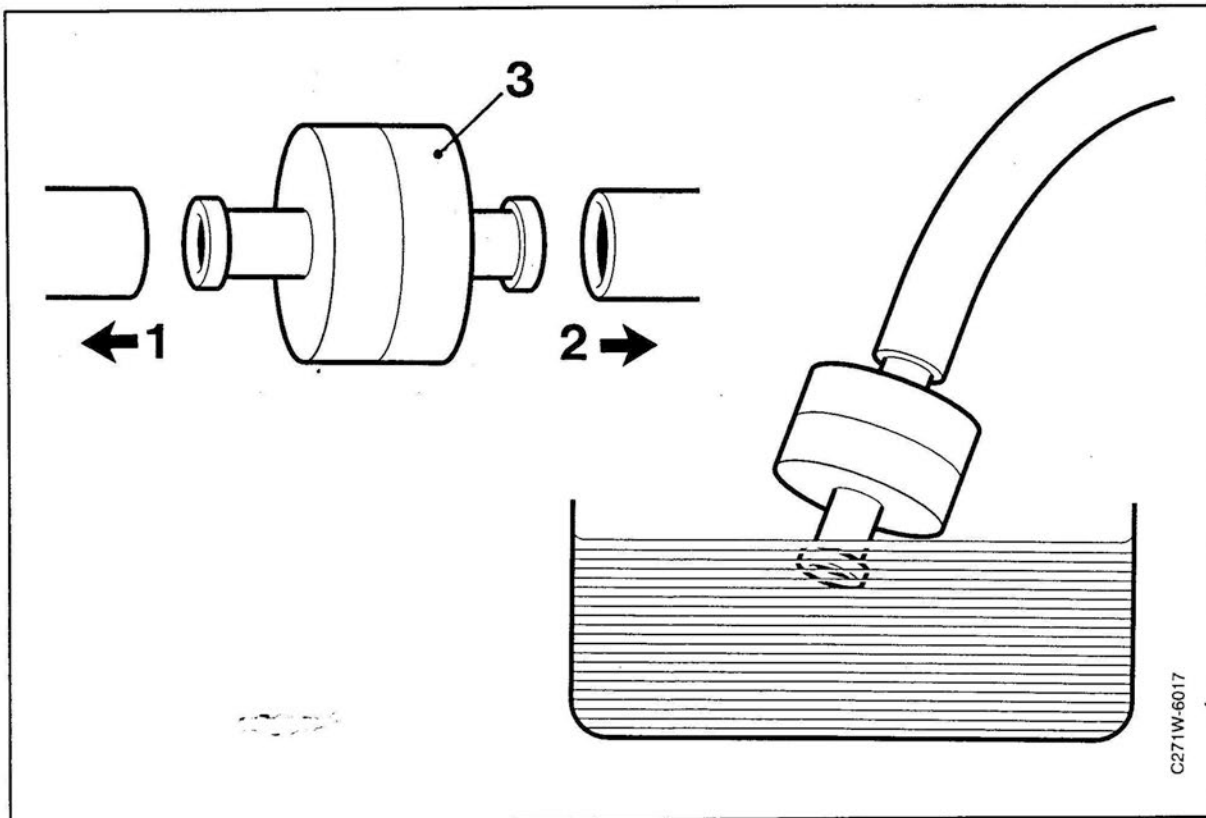

1. Safety valve

2. Intake manifold  
3. ID No. (eg. 930811)

## Bench Test

- 1 Apply a low pressure (less than 0.2 bar) to the red (or black) end of the valve.
- 2 Hold the white end under water.
- 3 The valve is OK if bubbles emerge at a rate of not more than 1 bubble per second.

### Preventive action for vacuum system

Check that the non-return valve is connected to the safety valve by means of the shorter hose. The red end must be connected to the intake manifold.

## ASR control module

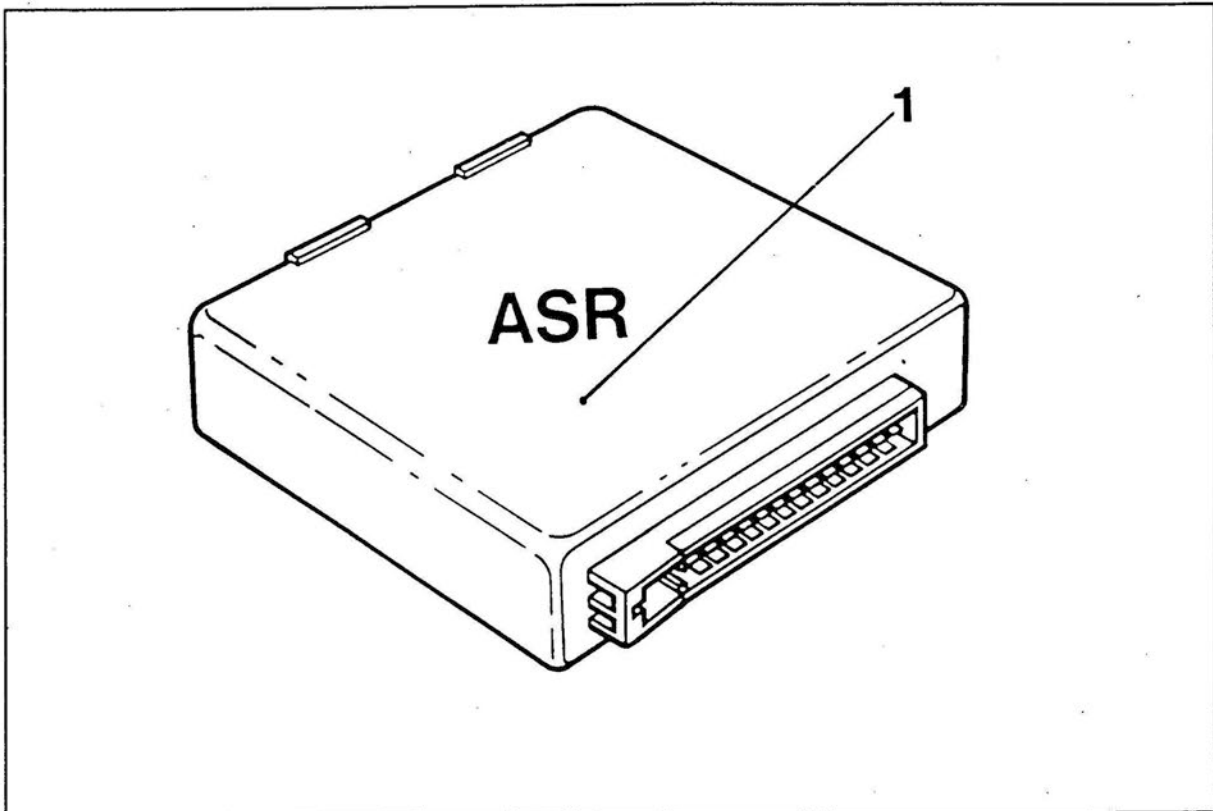

1. Identification No. (e.g. 142)

Part No. 4159190

### Updating of control module, M92

The software status of the ETS control module can be obtained by means of scan tool command code 380. For these updated control modules it should be 170292 (Feb. 17, 1992) or later. ASR control module status has also been updated but cannot be obtained by means of a scan tool. Instead, it is marked on the control module casing.

The updated control modules (ETS and ASR) have date code 112 or later. Date code 112 means that the control module was manufactured in week 11, year 1992.

M93 1/2 control modules are available from stock for replacement whenever necessary.

#### Important

The M93 1/2 (4300539) control module is the only control module that is fully compatible with all earlier model year cars.

Every model year has an individual code for the engine version concerned.

Replacement of a control module should be preceded by fault diagnosis. In principle, the control module should only be changed when diagnostic trouble code 4/25771 or 4/22220 is generated in the electronic throttle system (ETS) and displayed on a scan tool connected to the system (control modules before 170292).

## Accelerator pedal position sensor

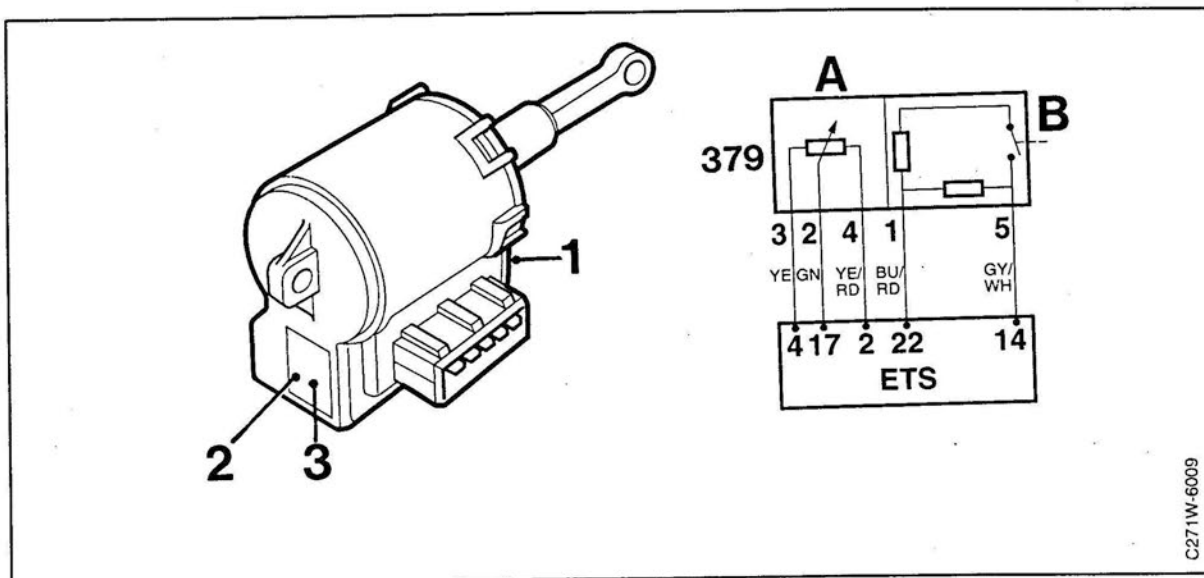

C271W-6009

- 1 Identification No. (e.g. 273)
- 2 Part No. 4161238 (AUT)
- 3 Part No. 4015194 (MAN)

- A. Potentiometer
- B. Safety switch

## Pedal safety switch test

- 1 Switch the ignition OFF.
- 2 Use a scan tool and a multimeter and plug a BOB (on ETS) into the components. Connect the multimeter to pins 14 (safety switch input) and 1 (GND). (Make sure the multimeter is set for measuring voltage.)
- 3 Plug in the scan tool and switch the ignition ON. Contact system No. 3 on the scan tool. Enter command code A09 (A0A for Saab part No. 4022653).
- 4 Note the scan tool reading (display: XX) when the pedal is released.
- 5 Check the multimeter (pedal in idle position) to see whether the switch is open (approx. < 1.5 V).
- 6 Press the pedal very slowly and watch the multimeter to see where the switching point occurs. (changes to approx. > 4.5 Volt).
- 7 Stop the pedal movement when the switching point occurs and keep the pedal in this position.
- 8 Look at the scan tool reading (display: XX). The switching point should be at least four numbers higher than the reading obtained with the pedal in the idle position. If it is not, replace the pedal sensor.

### Attention

The hexadecimal number seriation is:  
 (00;01;02;03;04;05;06;07;08;09;0A;0B;0C;0D;  
 0E;0F;10;11;...19;1A;...1F;20;21;...2A;...2F;30;  
 31;...)

### #3 EL THROTTLE (A09) 890XX 890YY

Scan tool display

Pos./HEX	XX	XX
Idle	0E	09
Switched	13	OD
Diff.	5	4



## Accelerator pedal position sensor

### Bench Test

- 1 Switch the ignition OFF.
- 2 Unplug the pedal position sensor connector.

#### Note

Take resistance readings between individual pins.

All pin numbers refer to the pedal sensor pins.

- 3 Pins 1 and 5  
not depressed, switch open  
 $R = 13.1 - 16.2 \text{ k } \Omega$   
  
Pins 1 and 5  
depressed (min 3 mm) switch closed  
 $R = 400 - 500 \Omega$
- 4 Pins 3 and 4 (all positions)  
 $R = 800 - 1200 \Omega$
- 5 Pins 2 and 4 not depressed  $R \geq 750 \Omega$   
Pins 2 and 4 fully depressed  $\leq 100 \Omega$
- 6 Pins 1 and 2  $R \geq 1 \text{ M } \Omega$  (OL)  
Pins 1 and 3  $R \geq 1 \text{ M } \Omega$  (OL)  
Pins 1 and 4  $R \geq 1 \text{ M } \Omega$  (OL)  
Pins 5 and 2  $R \geq 1 \text{ M } \Omega$  (OL)  
Pins 5 and 3  $R \geq 1 \text{ M } \Omega$  (OL)  
Pins 5 and 4  $R \geq 1 \text{ M } \Omega$  (OL)

#### Note

Before switching the ignition ON, make sure that all components and connectors are correctly fitted and plugged in.

#### Note

In cases where fault diagnosis indicates the accelerator pedal position sensor as the cause of the fault, the connector and the sensor's contacts should first be checked and sprayed with Kontakt 61.

Also check that the rubber cover round the connector has been removed (risk of corrosion).

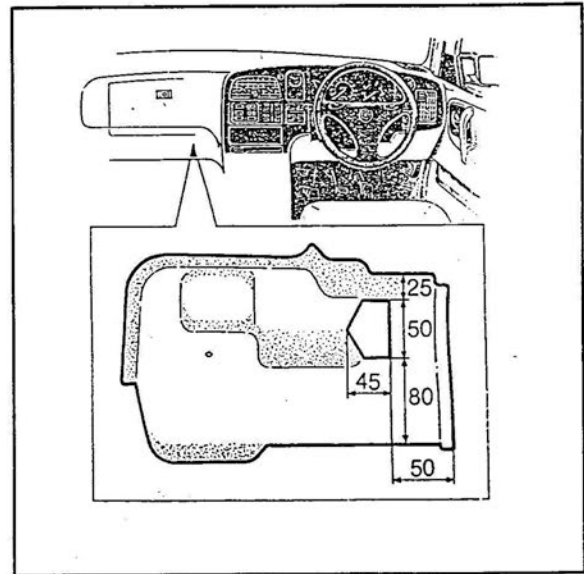

#### Note

Starting with chassis No. P1029694, a carpet cover with an opening to prevent contact with the pedal sensor's connector was introduced on RHD cars. If the opening is not large enough for any reason, cut away as much of it as necessary until it fulfils its purpose satisfactorily.

Carpet covers without a hole, part Nos. 4511572 (colour code 835), 4511556 (colour code 840) and 4511564 (colour code 845) were introduced from M94 1/2. This cover can also be fitted on earlier cars. A metal cover, part No. 4426532, was introduced at the same time as protection for the pedal sensor. This metal cover must always be fitted together with the new carpet.

## Accelerator pedal position sensor

### In-car component testing

- 1 If DTC 4/25721 or 4/25771 is generated, carry out the safety switch test first.
- 2 Switch the ignition OFF.
- 3 Wait 20 seconds.
- 4 Connect a BOB (ETS) and unplug the ETS and ASR control modules (aut only).

#### Note

Take resistance readings between individual pins.

All pin numbers refer to the BOB.

- 5 Pins 22 and 14  
not depressed, (switch open)  
 $R = 13.1 - 16.2 \text{ k } \Omega$

Pins 22 and 14  
depressed (min 3mm) (switch closed)  
 $R = 400 - 500 \Omega$

Pins 4 and 2 (all positions)  
 $R = 800 - 1200 \Omega$

Pins 17 and 2  
not depressed  $R \geq 750 \Omega$

Pins 17 and 2  
fully depressed  $\leq 100 \Omega$

Pins 22 and 17	$R \geq 1 \text{ M } \Omega$ (OL)
Pins 22 and 4	$R \geq 1 \text{ M } \Omega$ (OL)
Pins 22 and 2	$R \geq 1 \text{ M } \Omega$ (OL)
Pins 14 and 17	$R \geq 1 \text{ M } \Omega$ (OL)
Pins 14 and 4	$R \geq 1 \text{ M } \Omega$ (OL)
Pins 14 and 2	$R \geq 1 \text{ M } \Omega$ (OL)

#### Note

Before switching the ignition ON, make sure that all components and connectors are correctly fitted and plugged in.

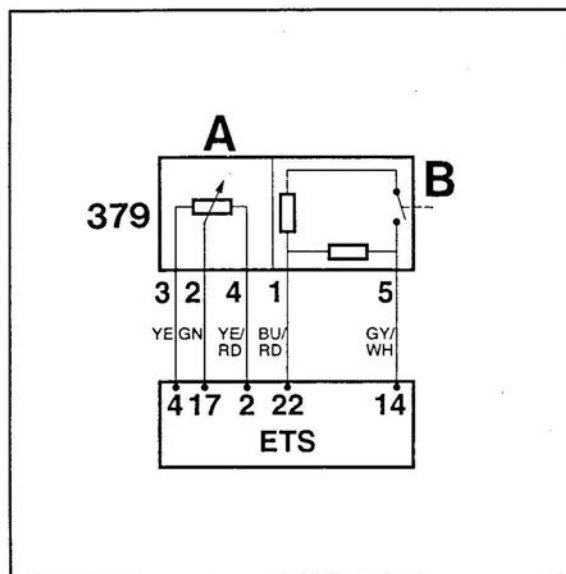

A. Potentiometer  
B. Safety switch

## Fault diagnosis/replacement of diodes in the ABS-TC/ABS system

### Background

On cars fitted with an ABS or TC/ABS system, the diodes incorporated in these systems may sometimes fail. Fault diagnosis and locating the faulty diodes may at times prove difficult. Commonly occurring fault symptoms and suitable methods of fault diagnosis and diode replacement are described in this section.

### Materials

Diode, part number 44 24 172.  
This diode is of type B4 252 GP G1.

### Special tools

Breakout box: 86 11 006  
35-pin test cable: 86 11 154  
55-pin TC/ABS cable: 86 11 030  
Multimeter, test instrument with diode testing or resistance measurement facilities.

Use the wiring diagram in Service Manual 3:2 for the relevant system when taking test readings.

### Diode location

The diodes are located under the relay base in the ABS main fuse box.

See table 4 for diode connections on the car versions concerned.

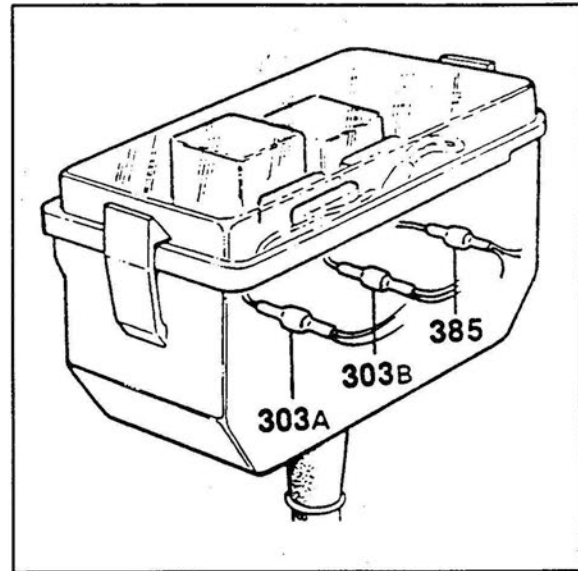

The diodes are located under the relay base in the ABS main fuse box.

## Fault diagnosis

The fault diagnosis section is divided into three areas:

- **A. ABS M87–M91 (9000)** page 49  
 Fault symptoms  
 Fault diagnosis
- **B. ABS M92 (9000), TC/ABS M90–93 (9000), ABS/ASR M92 (9000)** page 51  
 Fault symptoms  
 Fault diagnosis
- **C. ABS M93 (9000), ABS/ASR M93 (9000)** page 53  
 Fault symptoms  
 Fault diagnosis

## ABS M87–91 (9000)

### Fault symptoms

Table 1

Diode No. Cause of fault	Fault symptom
303A open circuit	The ANTI LOCK warning lamp does not light up when the ignition switch is in the Start position (should normally light up when the ignition switch is turned from the Drive position to the Start position, i.e. when the +54 supply is interrupted).
303A short circuit	The ANTI LOCK warning lamp lights up when the car is being driven. Diagnostic trouble code 1312 will be produced by the lamp–flash code. Note that the lamp–flash code will <b>not</b> be produced as long as there is a short circuit in the wiring.* On M1992 9000 models the scan tool will display diagnostic trouble code 36522.
303B short circuit	The "30A PUMP" fuse in the ABS main fuse box has blown.

\*) One way of reading the lamp–flash codes is to transfer the ABS control module to another car which has no faults.

## Fault diagnosis

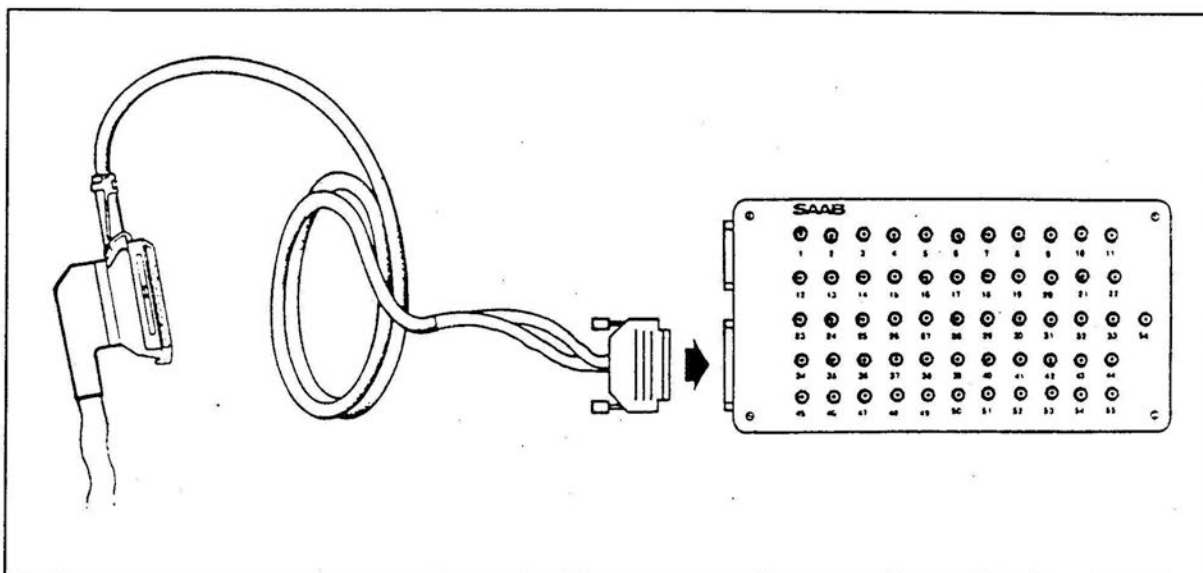

35-pin cable 86 11 154 and Breakout Box 86 11 006

### DIODE 303A

- 1 Unplug the 35-pin connector from the ABS control module and connect the breakout box to the wiring harness by means of the 35-pin cable, part No. 86 11 154.  
Do **not** connect the ABS control module.
- 2 Unplug the pump motor connector.
- 3 Remove the main relay ("MAIN RELAY") from the ABS main fuse box.
- 4 Measure the voltage drop across the diode with a diode tester plugged into sockets 20 and 27 on the breakout box:

#### A instrument negative to 20 and positive to 27

- Instrument reads < 0.4 V, probably short-circuited.
- Instrument reads approx. 0.5 V, diode OK.
- Instrument reads > 0.6 V – OL, probably open circuit.

#### B instrument positive to 20 and negative to 27

- Instrument reads 0.0 V, short circuit in diode.
- Instrument reads OL, diode OK.

In the event of an open circuit or short circuit, change the diode.

### DIODE 303B

- 1 Unplug the 35-pin connector from the ABS control module and connect the breakout box to the wiring harness by means of the 35-pin cable, part No. 86 11 154.  
Do **not** connect the ABS control module.
- 2 Unplug the pump motor connector.
- 3 Measure the voltage drop across the diode with a diode tester plugged into sockets 1 and 32 on the breakout box:

#### A instrument negative to 32 and positive to 1

- Instrument reads < 0.4 V, probably short-circuited.
- Instrument reads approx. 0.5 V, diode OK.
- Instrument reads > 0.6 V – OL, probably open circuit.

#### B instrument positive to 32 and negative to 1

- Instrument reads 0.0 V, short circuit in diode.
- Instrument reads OL, diode OK.

In the event of an open circuit or short circuit, change the diode.

**ABS M92 (9000)**  
**TC/ABS M91–M93 (9000)**  
**ABS/ASR M92 (9000)**

Fault symptoms

Table 2

Diode No. Cause of fault	Fault symptoms
385 short circuit	The TCS CTRL warning lamp does <b>not</b> light up when the ignition switch is in the Drive position (should normally light up and remain on for about 2 seconds).
385 open circuit	The TCS CTRL warning lamp does <b>not</b> light up when the ignition switch is in the Start position (should normally light up when the ignition switch is turned from the Drive position to the Start position, i.e. when the +54 supply is interrupted).
303A open circuit	The ANTI LOCK warning lamp does <b>not</b> light up when the ignition switch is in the Start position (should normally light up when the ignition switch is turned from the Drive position to the Start position, i.e. when the +54 supply is interrupted).
303A short circuit	The ANTI LOCK and TCS CTRL warning lamps light up when the car is being driven. The scan tool displays diagnostic trouble code 36522.
303B short circuit	The "30A PUMP" fuse in the ABS main fuse box has blown.

**Important**

Diode 385 is fitted only on cars with TC/ABS.

## Fault diagnosis

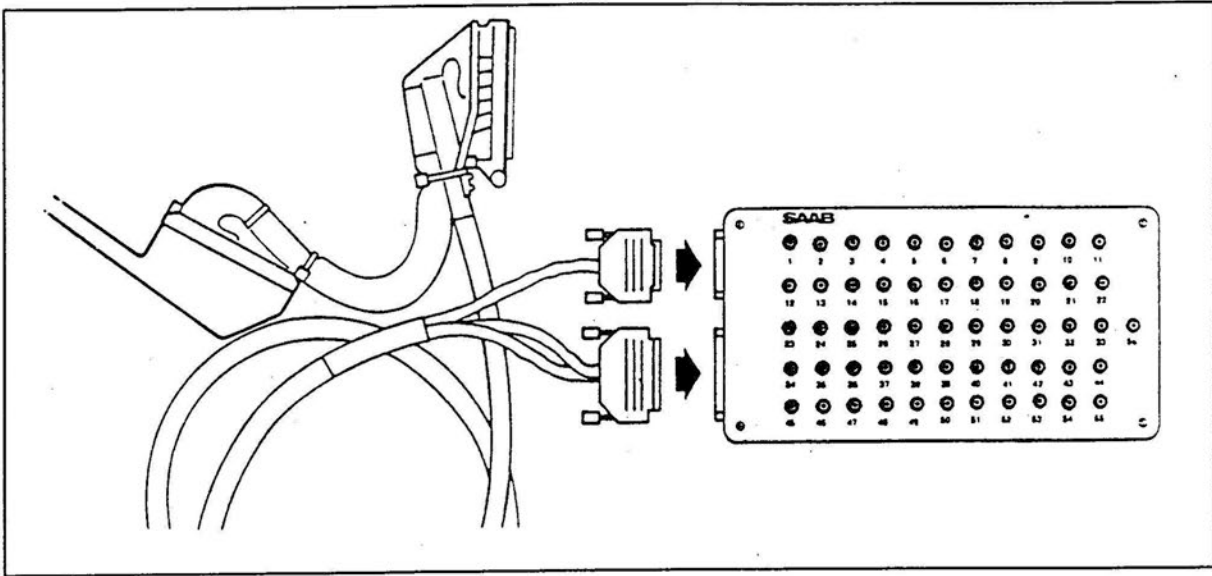

55-pin cable 86 11 030 and Breakout box 86 11 006

### DIODE 303A

- 1 Unplug the 55-pin connector from the ABS control module and connect the breakout box to the wiring harness by means of the 55-pin cable, part No. 86 11 030.  
Do **not** connect the ABS control module.
- 2 Unplug the pump motor connector.
- 3 Remove the main relay ("MAIN RELAY") from the ABS main fuse box.
- 4 Measure the voltage drop across the diode with a diode tester plugged into sockets 33 and 52 on the breakout box:

#### A instrument negative to 33 and positive to 52

- Instrument reads < 0.4 V, probably short-circuited.
- Instrument reads approx. 0.5 V, diode OK.
- Instrument reads > 0.6 V – OL, probably open circuit.

#### B instrument positive to 33 and negative to 52

- Instrument reads 0.0 V, short circuit in diode.
- Instrument reads OL, diode OK.

In the event of an open circuit or short circuit, change the diode.

### DIODE 303B

- 1 Unplug the 55-pin connector from the ABS control module and connect the breakout box to the wiring harness by means of the 55-pin cable, part No. 86 11 030.  
Do **not** connect the ABS control module.
- 2 Unplug the pump motor connector.
- 3 Measure the voltage drop across the diode with a diode tester plugged into sockets 1 and 14 on the breakout box:

#### A instrument negative to 14 and positive to 1

- Instrument reads < 0.4 V, probably short-circuited.
- Instrument reads approx. 0.5 V, diode OK.
- Instrument reads > 0.6 V – OL, probably open circuit.

#### B instrument positive to 14 and negative to 1

- Instrument reads 0.0 V, short circuit in diode.
- Instrument reads OL, diode OK.

In the event of an open circuit or short circuit, change the diode.

## DIODE 385

- 1 Unplug the control module connector and connect the breakout box to the wiring harness.
- 2 Unplug the pump motor connector.
- 3 Remove the main relay ("MAIN RELAY") from the ABS main fuse box.
- 4 Measure the voltage drop across the diode with a diode tester plugged into sockets 33 and 44 on the breakout box:

**A instrument negative to 33 and positive to 44**

- Instrument reads < 0.4 V, probably short-circuited.
- Instrument reads approx. 0.5 V, diode OK.
- Instrument reads > 0.6 V – OL, probably open circuit.

**B instrument positive to 33 and negative to 44**

- Instrument reads 0.0 V, short circuit in diode.
- Instrument reads OL, diode OK.

In the event of an open circuit or short circuit, change the diode.

## ABS M93 MK4 (9000) ABS/ASR M93 MK4 (9000)

## Fault symptoms

Table 3

Diode No. Cause of fault	Fault symptoms
303A open circuit	The ANTI LOCK warning lamp does <b>not</b> light up when the ignition switch is in the Start position (should normally light up when the ignition switch is turned from the Drive position to the Start position, i.e. when the +54 supply is interrupted).
303A short circuit	The ANTI LOCK warning lamp lights up only in the Start position and goes out as soon as the +54 power supply reaches the main relay via the ignition switch. The ANTI LOCK warning lamp should normally light up for 2–3 seconds after starting to show that the indicator lamp and control module are in working order.
303B short circuit	The "30A PUMP" fuse in the ABS main fuse box has blown.

**Important**

Diode 385 is fitted only on cars with TC/ABS.



## Fault diagnosis

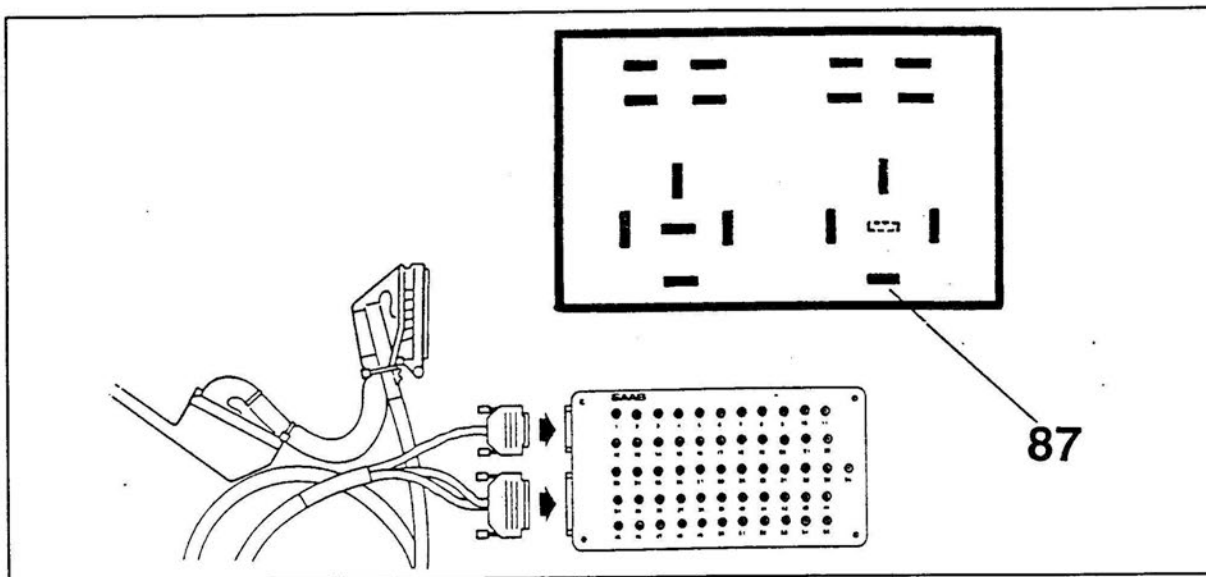

55-pin cable 86 11 030 and Breakout box 86 11 006

### DIODE 303A

- 1 Unplug the 55-pin connector from the ABS control module and connect the breakout box to the wiring harness by means of the 55-pin cable, part No. 86 11 030.  
Do **not** connect the ABS control module.
- 2 Unplug the pump motor connector.
- 3 Remove the main relay ("MAIN RELAY") and pump relay ("PUMP RELAY") from the ABS main fuse box.
- 4 Measure the voltage drop across the diode with a diode tester plugged into sockets 33 and 52 on the breakout box:

#### A instrument negative to 33 and positive to 52

- Instrument reads < 0.4 V, probably short-circuited.
- Instrument reads approx. 0.5 V, diode OK.
- Instrument reads > 0.6 V – OL, probably open circuit.

#### B instrument positive to 33 and negative to 52

- Instrument reads 0.0 V, short circuit in diode.
- Instrument reads OL, diode OK.

In the event of an open circuit or short circuit, change the diode.

### DIODE 303B

- 1 Unplug the 55-pin connector from the ABS control module and connect the breakout box to the wiring harness by means of the 55-pin cable, part No. 86 11 030.  
Do **not** connect the ABS control module.
- 2 Unplug the pump motor connector.
- 3 Measure the voltage drop across the diode with a diode tester plugged into sockets 87 and 1 on the breakout box:

#### A instrument negative to 87 and positive to terminal 1 on the relay base

- Instrument reads < 0.4 V, probably short-circuited.
- Instrument reads approx. 0.5 V, diode OK.
- Instrument reads > 0.6 V – OL, probably open circuit.

#### B instrument positive to 87 and negative to terminal 1 on the relay base

- Instrument reads 0.0 V, short circuit in diode.
- Instrument reads OL, diode OK.

In the event of an open circuit or short circuit, change the diode.

## Diode replacement

- 1 Remove the ABS main fuse box from its mounting bracket. Undo the two screws securing the relay base and pull it up so that the diodes will be accessible. Consult table 4 to find out which diode corresponds to the faulty one.
- 2 Cut off one of the faulty diode's leads at the crimp and remove the insulating sleeve.
- 3 Solder one of the new diode's leads to the crimp. Be sure to fit the diode with the banded end facing in the same direction as the old one. Compare it with the old diode or consult table 4.

### Important

Be careful not to apply heat for too long a time to the soldered joint as this could easily cause damage to the diode and cable insulation.

- 4 Cut off the diode's remaining lead at the other crimp. Remove the insulating sleeve from the crimp.

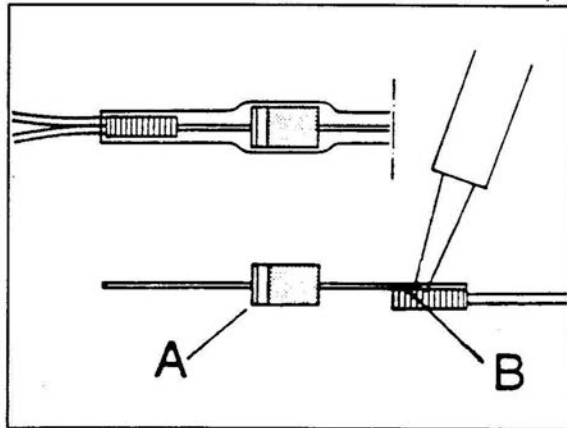
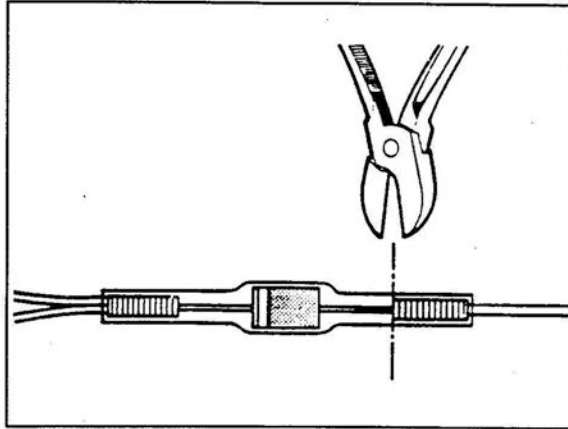

A New diode  
B Soldering

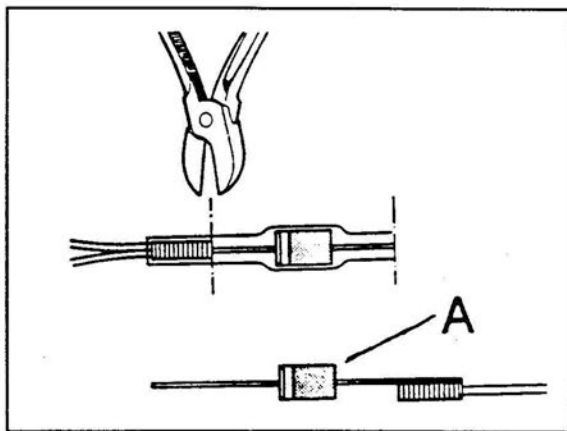

A New diode

## 56 Diagnostic procedures

5 Solder the new diode's remaining lead to the other crimp.

### Important

Be careful not to apply heat for too long a time to the soldered joint as this could easily cause damage to the diode and cable insulation.

Use insulating tape to insulate the soldered joints and diode.

We recommend changing the other diode (or the two other diodes) also by repeating points 2 to 5 above.

Refit the relay base and the ABS main fuse box. Check that the three fuses in the ABS main fuse box are intact.

Check the operation of the diodes by turning the ignition switch to the Drive position.

If the diodes are correctly connected, the ANTI LOCK warning lamp (and the TCS CTRL warning lamp, if fitted) should light up at the same time as the ignition is switched on.

Check the pump motor by depressing the brake pedal a few times until the pump starts. When the pump motor has started, check that the pump fuse in the ABS main fuse box is intact and that the ANTI LOCK warning lamp is not on (nor the TCS CTRL warning lamp, if fitted).

If any diode has been fitted the wrong way round, the fault symptoms for the relevant diode will be evident from table 4.

Clear the diagnostic trouble codes, if any. Start the engine and check that the warning lamps go out shortly afterwards.

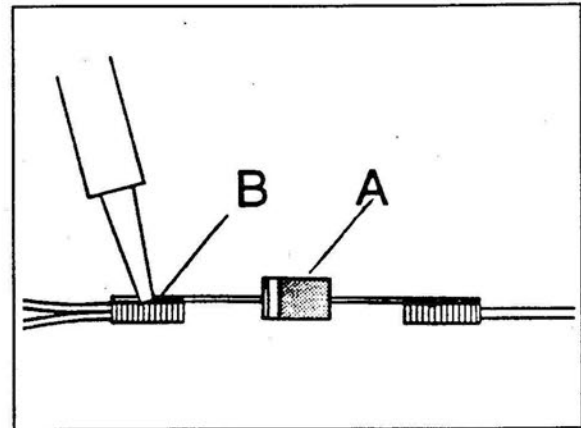

A New diode  
B Soldering

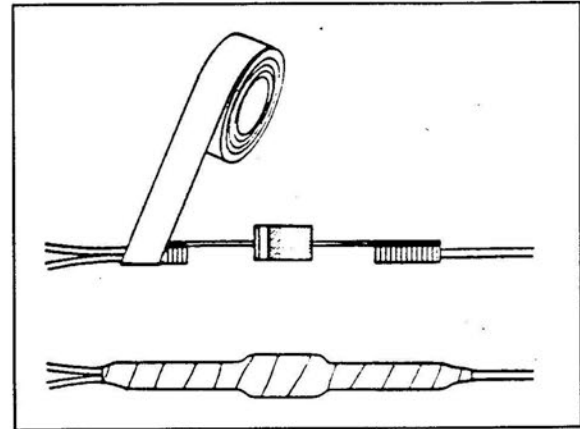

## Checking that the diodes are correctly connected

Turn the ignition switch to the Drive position and observe how the ANTI LOCK (diode 303A) and TCS CTRL (diode 385) warning lamps light up.

### Important

The operation of the warning lamps described below presupposes that there is **full accumulator pressure in the system.**

Table 4

Version	Diode	Operation, diode fitted correctly	Operation, diode fitted incorrectly
9000 TCS M91-93  9000 ASR M92	303A	ANTI LOCK lights up and goes out after 2-3 seconds.	ANTI LOCK lights up after 2-3 seconds and stays on. TCS CTRL also lights up and stays on.
	303B	Normal pump operation.	The pump fuse in the ABS main fuse box has blown and the pump motor fails to run.
	385	TCS CTRL lights up and goes out after 2-3 seconds.	TCS CTRL does not light up.
9000 MK4 M93  9000 ASR M93	303A	ANTI LOCK lights up and goes out after 2-3 seconds.	ANTI LOCK does not light up.
	303B	Normal pump operation.	The pump fuse in the ABS main fuse box has blown and the pump motor fails to run.

## Diode connections

← Direction of current flow



Diode symbol in wiring diagram:

Actual diode

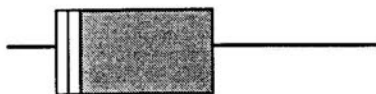

Table 5

Version	Connected lead	Diode 303A	Connected lead	Connected lead	Diode 303B	Connected lead	Connected lead	Diode 385	Connected lead
ABS 9000 M1987-92	Yellow/white		White + White	Yellow + Blue		Black			
ABS 9000 M1993 MK4	Yellow/white		White + White	Yellow + Yellow		Black			
TCS 9000 M 1991	Yellow/white		White + White	Blue		Black	Yellow/white		Blue + Blue
TCS 9000 M 1992	Yellow/white		White + White	Yellow + Yellow		Black	Yellow/white		Blue + Blue
TCS 9000 M 1993	Yellow/white		White + White	Yellow + Blue		Black	Yellow/white		Blue + Blue
ASR 9000 M 1992	Yellow/white		White + White	Yellow + Yellow		Black			
ASR 9000 M 1993 MK	Yellow/white		White + White	Yellow		Black			

## Quick-reference pin chart, ETS control module

Pin No.	Designation	Input/Output
1	Main Ground	input
2	Pedal Sensor (+)	output
3	Throttle Housing (+)	output
4	Pedal Sensor (-)	output
5	Throttle Housing (-)	output
6	Charge Air Bypass Control Valve	output
7	Main Ground (ETS internal)	not used
8	Not used	-
9	Diagnostic L — Line (Scan Tool to control module)	input
10	Vehicle Speed	input
11	Not used	-
12	Engine Speed (rpm signal)	input
13	Main Relay Control Circuit	output
14	Pedal Sensor Safety Switch	input
15	Brake Light Switch	input
16	Throttle Position Sensor	input
17	Pedal Position Sensor	input
18	Cruise Control RESUME	input
19	Cruise Control SET	input
20	Throttle Motor (pin 1)	output
21	Throttle Motor (pin 7)	output
22	+ 30 switched from Main Relay	input
23	TCS CTRL Lamp control signal	output
24	Not used	-
25	+ 15 switched from Ignition Switch	input
26	Throttle Position (PWM signal)	output
27	Tq — signal (Load signal)	input
28	Throttle Body Safety Switch	input
29	TC/ASR Communication Link IN	input
30	Not used	-
31	Cruise Control ON/OFF Switch	input
32	TC/ASR Communication Link OUT	output
33	Engine Coolant Temperature Sensor	input
34	Diagnostic K — Line (control module to Scan Tool)	output
35	Safety Valve control signal	output
36	Brake/Clutch Switches	input
37	ACC request	input
38	ACC relay control circuit	output

**Quick-reference pin chart, ASR control module**

Pin No.	Designation	Input/Output
1	Accelerator Pedal Position Sensor	input
2	ETS Communication Link IN	input
3	Throttle Position Sensor	input
4	Not used	—
5	Not used	—
6	Not used	—
7	Accelerator Pedal Position Sensor (+)	input
8	Wheel Speed Signal (Rear Left)	input
9	Wheel Speed Signal (Front Right)	input
10	Wheel Speed Signal (Front Left)	input
11	Kick Down Actuator (+)	output
12	+ 15 switched from Ignition Switch	input
13	Main Ground	input
14	ETS Communication Link OUT	output
15	Kick Down Actuator (—)	output
16	Gear Selector Signal (N/D switch)	input
17	Not used	—
18	Engine Speed (rpm signal)	input
19	TCS lamp (check)	output
20	Throttle Position Sensor (+)	input
21	Wheel Speed Signal (Rear Right)	input
22	KDA Position Sensor	input
23	KDA Motor (pin 7)	output
24	KDA Motor (pin 1)	output
25	+ 30 switched from Main Relay	input

### **Pay attention to the following**

Other systems in the car can cause the CTRL lamp to light up (such as the ABS and engine management systems).

If diagnostic trouble codes are not generated, check the pressure switch in the ABS system.

If the ANTI LOCK lamp lights up when the CTRL lamp lights up, start fault diagnosis in the anti-lock brake system (ABS).

### **General hints**

Before taking voltage readings, it is advisable to check the system for shorting to ground and/or B+ using a multimeter.

Voltage readings are based on an active system (IGN ON).

ETS pin 1 and ASR pin 13 are the main ground reference points for all readings.

All readings are to be taken using a BOB.

Make sure that the multimeter is set to the right scale.

If possible, use an oscilloscope to gain a clearer understanding of the various system signals. (Oscilloscope plots will be found in the section "ETS reference graphs").



## Pin & cable checks ETS control module

U = voltage

Pin	In/ Out	Colour	No.	Function	Test	Remarks
1	in	BK	990	Main Ground	Check voltage drop to G7: less than 0.1 V	
2	out	YE/RD	983	Accelerator pedal sensor (+)	Reading should be steady at 4.3–5.4 V	Sensor supply voltage (+)
3	out	YE/WH	977	Throttle sensor (+)	Reading should be steady at 4.3.1–5.4 V	Sensor supply voltage (+)
4	out	YE	985	Accelerator pedal sensor (-)	Reading should be steady at 0.1–0.2 V	Sensor supply voltage (-)
5	out	WH	979	Throttle sensor (+)	Reading should be steady at 0.1–0.2 V	Sensor supply voltage (-)
6	out	GY	986	Charge air bypass control valve	Not activated: U > 10V Activated: U < 1V	Scan tool code 552: Control valve signal pulsing at 1 Hz
7				Not used		Internal connection to main ground
8				Not used		
9	in	YE	963	Diagnostic L — (Scan tool to control module)	Scan tool disconnected: U > 10V	
10	in	GN/RD	992	Vehicle speed signal from speedometer	U <sub>max</sub> > 8 V U <sub>min</sub> < 1 V	Should change when front wheel is rotated slowly by hand
11				Not used		

**Notes:**

## Pin and cable checks ETS (contd.)

U = voltage

Pin	In/ Out	Colour	No.	Function	Test	Remarks
12	in	OG	706	Engine speed to rpm signal from DI/APC, pin 29 (Trionic, pin 58)	$U_{\max} > 8 \text{ V}$ $U_{\min} < 1 \text{ V}$ but no intermediate readings	Scan tool code 249: Reading: 80XXX (at idle 80850)
13	in	BU	974	Main Relay Control Circuit	Ignition OFF: $U = B+$ Ignition ON: $U < 2 \text{ V}$	Pin is internally grounded if ETS-system is not in Limp-Home mode
14	in	GY/WH	982	Acc. pedal sensor safety switch (from acc. pedal sensor, pin 5)	Accelerator pedal released: $U < 1.5 \text{ V}$ , depressed more than halfway: $U > 4.5 \text{ V}$	Scan tool code 207: pedal released = 8B007, pedal depressed = 8B107
15	in	WH	987	Brake Light Switch	Brake released: $U < 0.3 \text{ V}$ Brake depressed: $U > 10 \text{ V}$	Scan tool code 206: Brake released = 8B006 Brake depressed = 8B106 TEST ASSUMES ALL BRAKE LIGHTS ARE OK.
16	in	BU	978	Throttle Sensor position (from throttle body, pin 4)	Accelerator pedal released: $U = 3.4 - 5.4 \text{ V}$ Pedal slowly depressed: reading should decrease but not below $U = 0.1 \text{ V}$	$U_{\max} < U_{\text{pin } 3}$ (sensor (+))  $U_{\max} > U_{\text{pin } 5}$ (sensor (-))

## Notes:

Notes:

**Pin and cable checks ETS (contd.)**

U = voltage

Pin	In/ Out	Colour	No.	Function	Test	Remarks
17	in	GN	984	Acc. pedal position sensor (from pedal sensor, pin 2)	Acc. pedal fully released: $U < 1\text{ V}$ Pedal slowly depressed: reading should increase but not above $U = 5.4\text{ V}$	$U_{\max} > U_{\text{pin } 4}$ (sensor (-))  $U_{\max} < U_{\text{pin } 2}$ (sensor (+))
18	in	YE	601	Cruise Control "RESUME" (from pin 3 main cruise control switch)	Released: $U < 1\text{ V}$ Depressed: $U > 10\text{ V}$	
19	in	RD/WH	602	Cruise Control "SET" (from pin 2 main cruise control switch)	Released: $U < 1\text{ V}$ Depressed: $U > 10\text{ V}$	
20	out	GN	981	Throttle motor 2 (from throttle body, pin 1)	Pedal released: $U \approx 0\text{ V}$ Fully depressed: $U \approx 4\text{ V}$	Throttle motor 2 closes the throttle (PWM)
21	out	GN	980	Throttle motor 1 (from throttle body, pin 7)	Pedal (throttle) in fixed position: $U < 0.5\text{ V}$ while closing: $U$ increases to about $2\text{ V}$	Throttle motor 1 opens the throttle (PWM)
22	in	BU/RD	972	+30 switched from main relay, pin 87	Relay activated: $U \approx B+$ not activated: $U \approx 0\text{ V}$	Supply voltage for the ETS control module
23	out	VT/WH	970	TCS CTRL Lamp control signal	Lamp "ON": $U < 1\text{ V}$ Lamp "OFF": $U > 10\text{ V}$	
24				Not used		
25	in	GN/WH	991	+15 switched from ignition key	IGN "ON": $U \approx B+$ IGN "OFF": $U = 0\text{ V}$	Supply voltage

**Notes:**

## Pin and cable checks ETS (contd.)

U = voltage

Pin	In/ Out	Colour	No.	Function	Test	Remarks
26	out	YE	965 (LH) 966A (Tri)	Throttle Position PWM Signal (Butterfly angle for LH/DI or TRIONIC)	Frequency: LH/DI 100 Hz Trionic 200 Hz Pulse width increases with butterfly opening	IGN ON: U > 1 V Engine at idle: U ≈ 1 V Throttle wide open: U ≈ B+
27	in	WH	716A	Load signal (tq) (from DI, pin 36 and from TRIONIC, pin 35)	Scan tool 281: idle = 30–50 μs full load = 400–500 μs	Pulse width in μs Reading: 80xxx min > 25 (80025) max < 512 (80512)
28	in	BK/WH	976	Throttle sensor safety switch (throttle housing, pin 5)	Throttle closed: U < 1.5 V Throttle open: U > 6.4 V	Scan tool code 208: closed = 8B008 more than halfway open = 8B10B
29	in	GN/WH (YE)	MAN 968 AUT 1127	TC/ASR communication (link IN) (from TC/ABS pin 24 (MAN), ASR pin 14 (AUT))	Communication OK: U = 6–7 V	faulty link: higher or lower readings
30				Not used		
31	in	RD	603	Cruise Control ON/OFF switch (from Pin 1 main cruise control switch)	"ON": U ≈ B+ "OFF": U < 0.5 V	Scan tool code 202: ON = 8B102 OFF = 8B002
32	out	BK/WH	MAN 969 AUT 1128	TC/ASR communication (link OUT) (from TC/ABS pin 4 (MAN) and from ASR, pin 2 (AUT))	Communication OK: U = 6–7 V	faulty link: higher or lower readings

## Notes:

**Pin and cable checks ETS (contd.)**

U = voltage

Pin	In/ Out	Colour	No.	Function	Test	Remarks
33	in	YE	989	Engine coolant temperature system	Scan tool code 250: 80+0xx or 80</>+xx (example: 80+025=>25°C	Scan tool display range is from -30°C to +50°C. With ETC sensor characteristic 25°C= 3.2 V
34	out	BU/WH	896B	Diagnostic K — line (control module to scan tool)	Scan tool disconnected: U = 0 V	Scan tool connected: U = B+
35	out	BN/WH	975	Safety Valve control signal	ON: U < 2.0 V OFF: U ≈ B+	Scan tool command code 551: valve pulsing at 1 Hz
36	in	VT	616	Brake/clutch switches	<b>Both pedals released:</b> U ≈ B+ <b>One of the pedals depressed</b> U < 1.0 V	Scan tool code 205: released = 8B005 depressed = 8B105
37	in	YE	993	ACC request (from anti-frost switch)	ON: U ≈ B+ OFF: U < 1.0 V	
38	out	BK	994	ACC relay control circuit	Activated: U < 1.0 V not activated: U ≈ B+	Scan tool code 550: Relay pulsing at 1 Hz

**Notes:**

## Pin and cable checks, ASR control module

U = voltage

Pin	In/ Out	Colour	No.	Function	Test	Remarks
1	in	GY	984A	Acc. pedal position sensor (from pedal sensor, pin 2)	Acc. pedal fully released: $U < 1$ V Pedal slowly depressed: reading should increase but not above $U = 5.4$ V	$U_{\min} > U_{\text{pin 4}}$ (sensor (-))  $U_{\max} < U_{\text{pin 2}}$ sensor (+)
2	in	BK/WH	1128	TC/ASR Communication (link OUT) (from MAN: TC/ABS pin 4, from AUT: ASR pin 2)	Communication OK: $U = 6-7$ V	faulty link: higher or lower readings
3	in	BU	978A	Throttle position sensor (from throttle body, pin 4)	Acc. pedal fully released: $U = 3.4 - 5.4$ V Pedal slowly depressed: reading should decrease but not below $U = 0.1$ V	$U_{\max} < U_{\text{pin 3}}$ (sensor (-))  $U_{\min} > U_{\text{pin 5}}$ (sensor (-))
4-6				Not used		
7	in	YE/RD	983A	Acc. pedal+	Reading should be steady at 4.3-5.4 V	Sensor supply voltage (+)
8	in	GY	1101	Wheel speed signal (RL) from ABS, pin 12	Rotate wheel: "pulse rate" should increase with wheel speed (Logic Probe)	With scan tool PULSE mode  car stationary: frequency = 14 Hz, (tolerance = 9-19 Hz)  car in motion: 1 km/h $\approx$ 13 Hz Example: 100 km/h $\approx$ 1.3 kHz
9	in	BU	1102	Wheel speed signal (FR) from ABS, pin 11		
10	in	YE	1103	Wheel speed signal (FL) from ABS, pin 10		

### Notes:

**Pin and cable checks, ASR control module (contd.)**

U = voltage

Pin	In/ Out	Colour	No.	Function	Test	Remarks
11	out	YE/RD	1098	Kick Down Actuator (+)	Reading should be steady at 4.3–5.4 V	Sensor supply voltage (+)
12	in	GN/WH	991A	+15 switched from ignition key	IGN "ON" U = B+ IGN "OFF" U = 0 V	Supply voltage
13	in	BK	990A	Main Ground	Check voltage drop to G7: less than 0,1 V	
14	in	GN/WH	MAN 968	ETS communication link out (to ETS, pin 29)	Communication OK: U = 6–7 V	faulty link: higher or lower readings
15	out	RD	1098	Kick Down Actuator (-)	Reading should be steady at 0.1–0.2 V	Sensor supply voltage (-)
16	in	OR	MAN 334B	Gear selector signal (N/D switch) from LH pin 30, from TRIONIC pin 14	Lever Position R,D,3,2,1 : U ≈ B+ P,N: U ≈ 0 V	
17				Not used		
18	in	OG	706B	Engine speed to rpm Signal from DI/APC pin 29 or Trionic pin 58	U <sub>max</sub> > 8 V U <sub>min</sub> < 1 V but no intermediate readings	Scan tool code 249: 80xxx (at idle 80850)
19	out	BN/WH	1129	TCS indicator lamp	Lamp ON: U < 1.0 V Lamp OFF: U ≈ B+	

**Notes:**

Notes:

**Pin and cable checks, ASR control module (contd.)**

U = voltage

Pin	In/ Out	Colour	No.	Function	Test	Remarks
20	out	YE/WH	977A	Throttle Position Sensor (+)	Reading should be steady at 4.3–5.4 V	Sensor supply voltage (+)
21	in	GN	1104	Wheel speed signal (RR)	Check ASR pins 8, 9 and 10	
22	in	BU/RD	1097	Kick Down actuator sensor position (from KDA, pin 5)	Acc. pedal fully released: $U < 1 \text{ V}$ Pedal slowly depressed: reading should increase but not above $U = 5.4 \text{ V}$	$U_{\text{min}} > U_{\text{pin 15}}$ (sensor (-)) $U_{\text{max}} < U_{\text{pin 11}}$ (sensor (+))
23	out	BU/WH	1099	KDA motor 2 (to KDA, pin 7)	DC motor test, see page 32	releasing the KD cable
24	out	WH	1100	KDA motor 1 (to KDA, pin 1)	DC motor test, see page 32	pulling the KD-wire
25	in	BU/RD	972	+30 switched from main relay, pin 87	Relay activated: $U \approx B+$ not activated: $U \approx 0 \text{ V}$	Supply voltage for the control module

**Notes:**



### DTC fault tracing charts

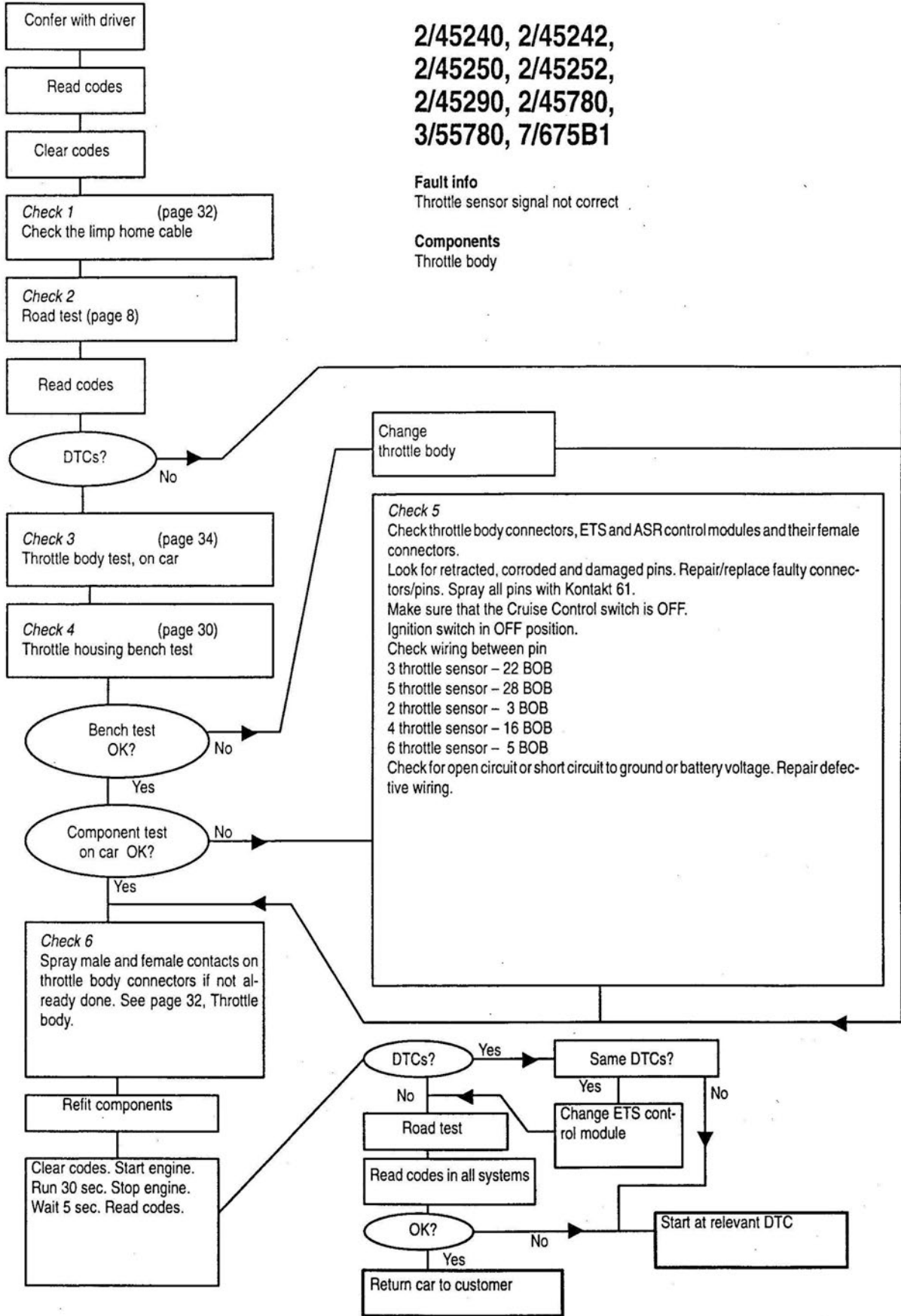

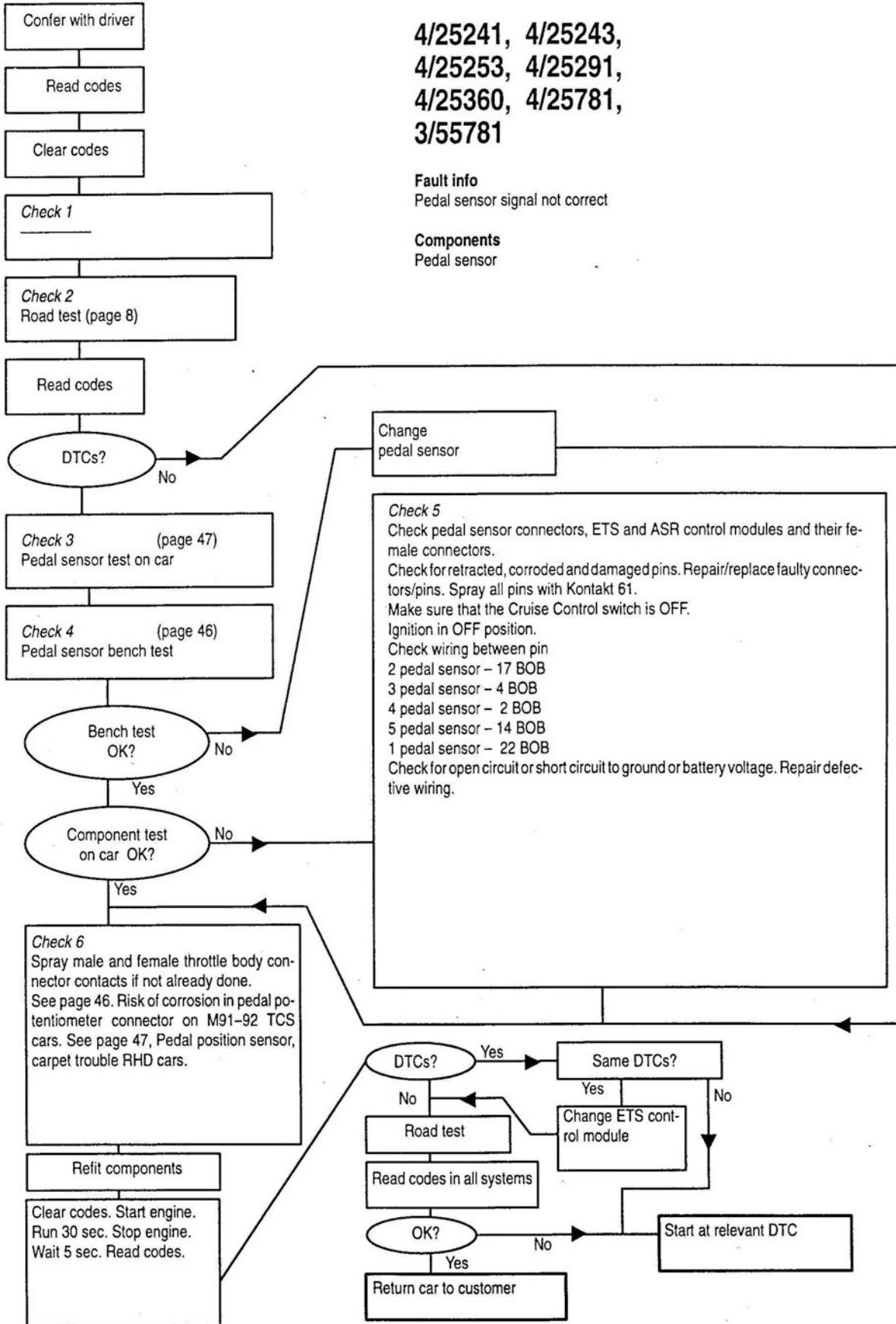

**2/45251**

**Fault info**  
Pedal sensor signal not correct

**Components**  
Pedal sensor

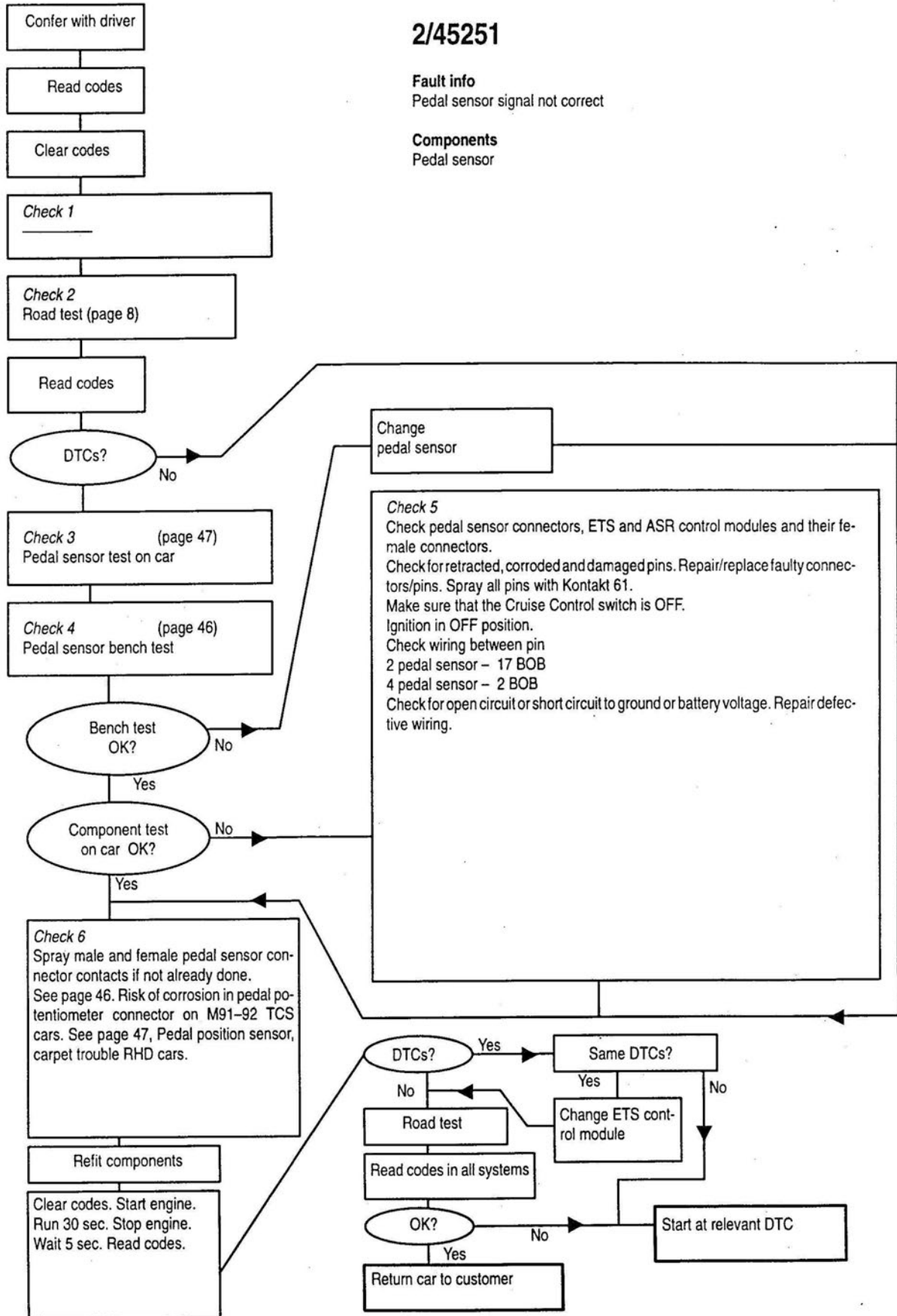

**4/25720, 4/25770**

**Fault info**  
Throttle sensor signal not correct

**Components**  
Throttle body

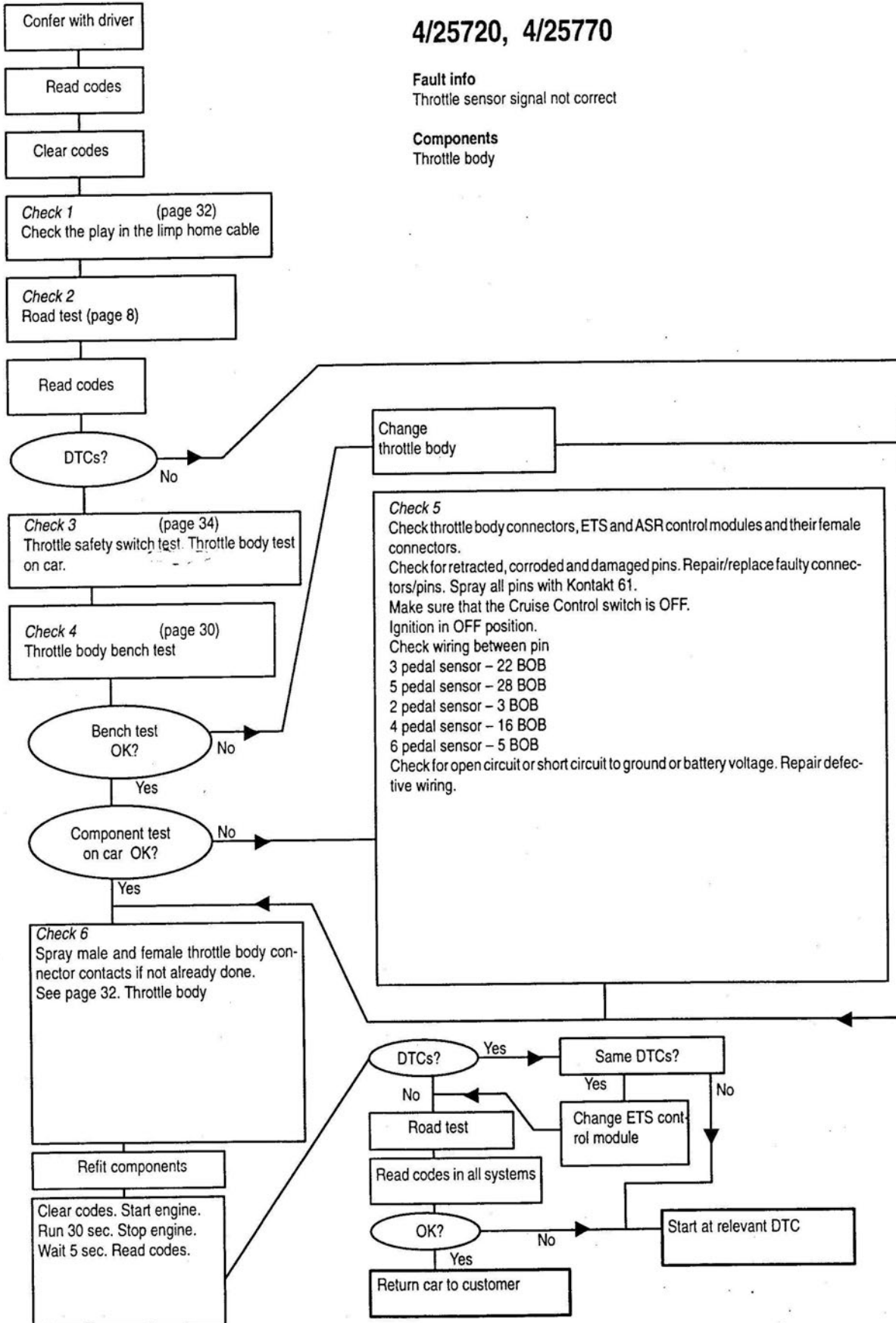

**4/25721, 4/25771**

**Fault info**  
Pedal sensor signal not correct

**Components**  
Pedal sensor

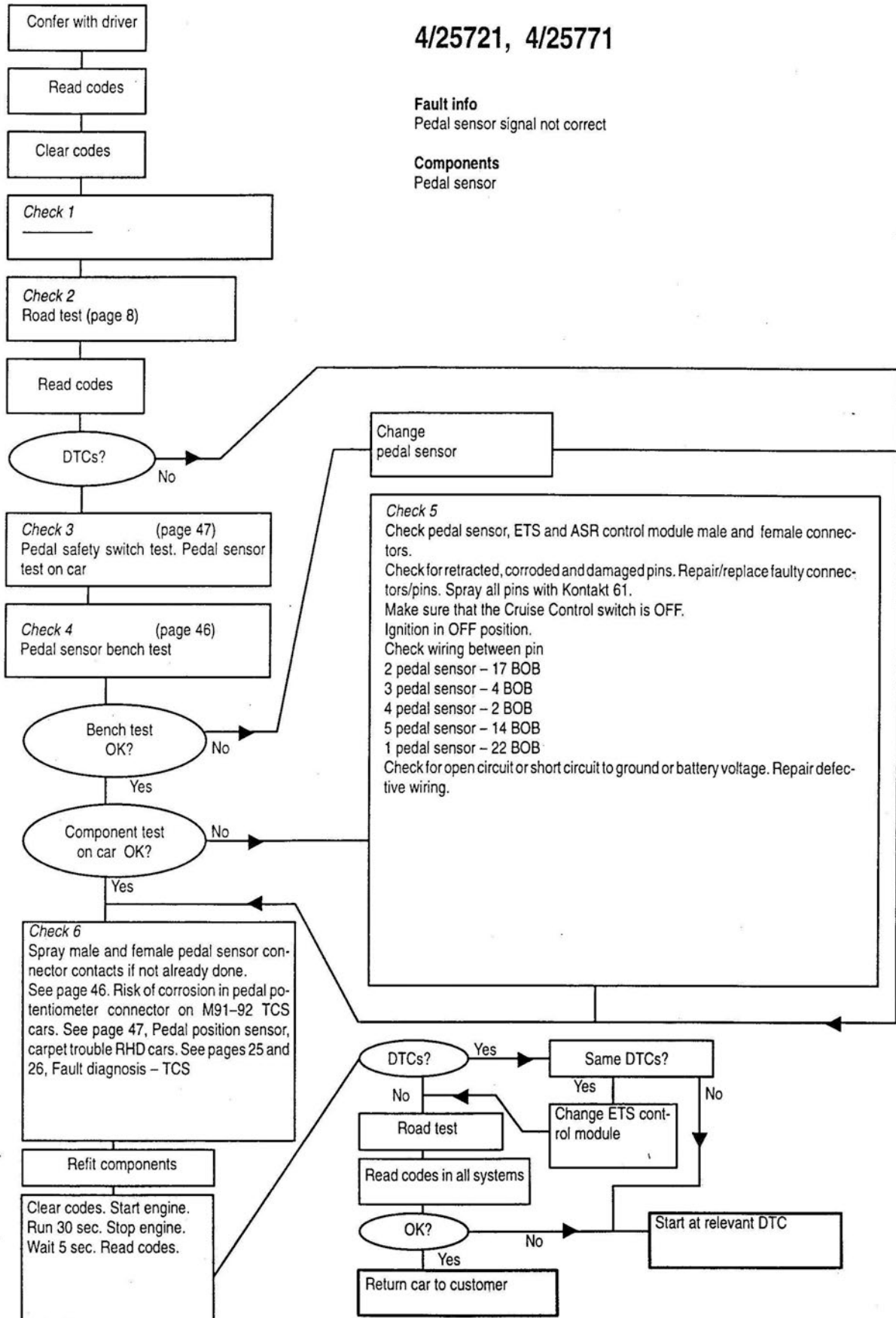

### 4/24291, 4/24290

**Fault info**

Discrepancy in speed signals from speedometer and ABS/TCS (manual) or ASR (automatic) greater than +/- 10 km/h.  
Vehicle speed >30 km/h.

**Components**

Speedometer  
Wheel sensors

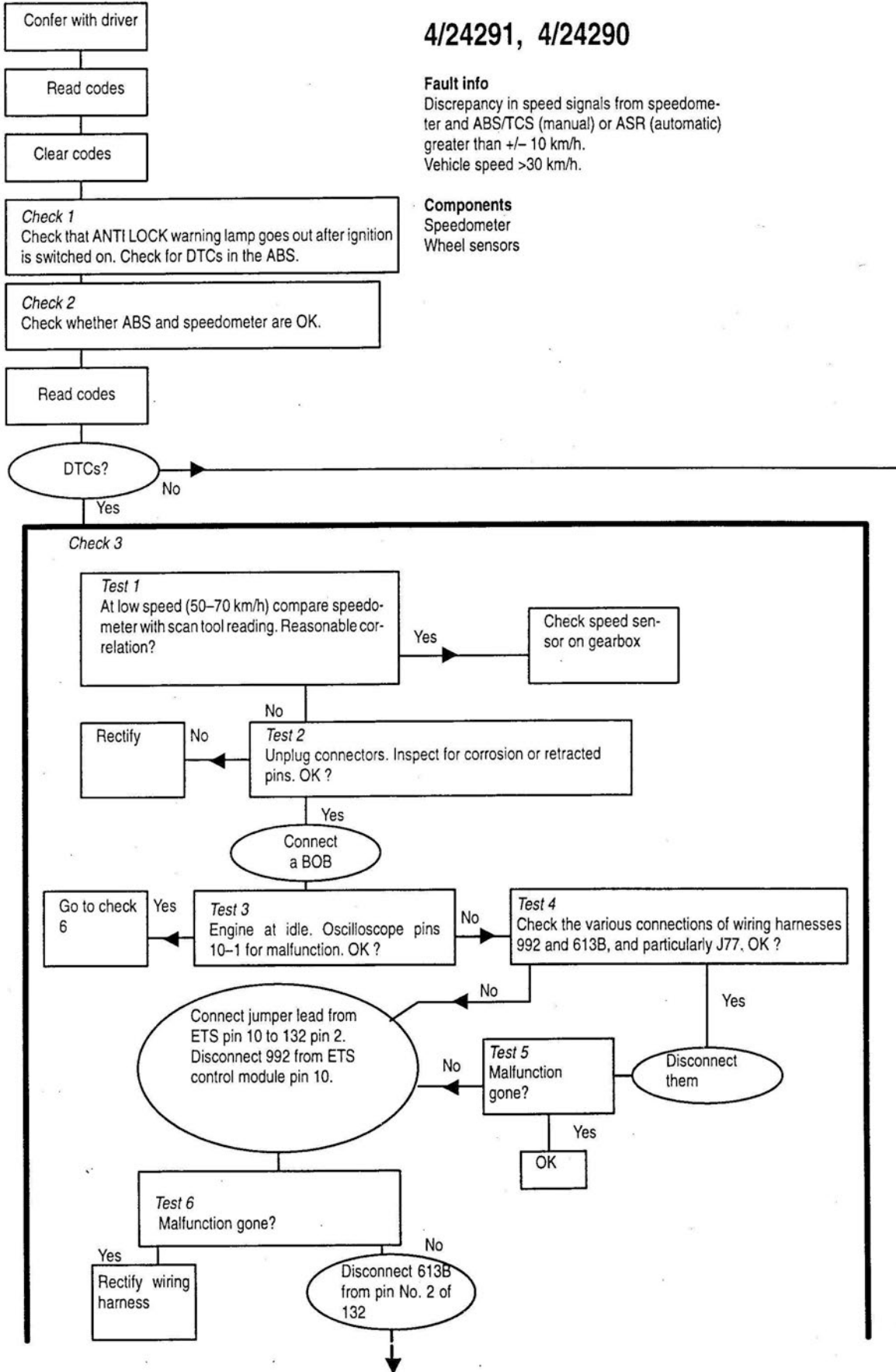

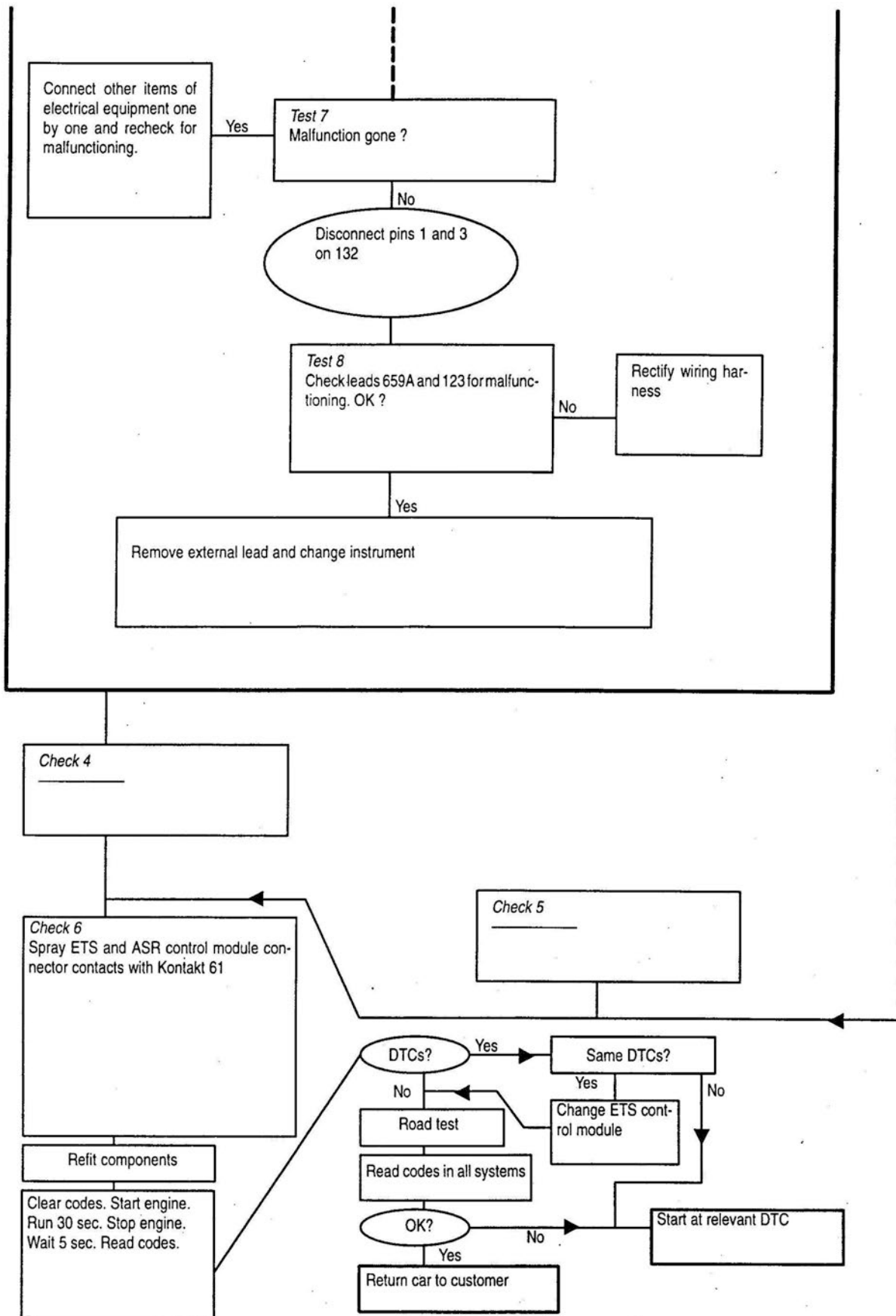

### D/E7590

**Fault info**  
The limp home mechanism does not work properly.

**Components**  
Throttle body  
Limp home cable  
Pneumatics (safety valve and hoses)

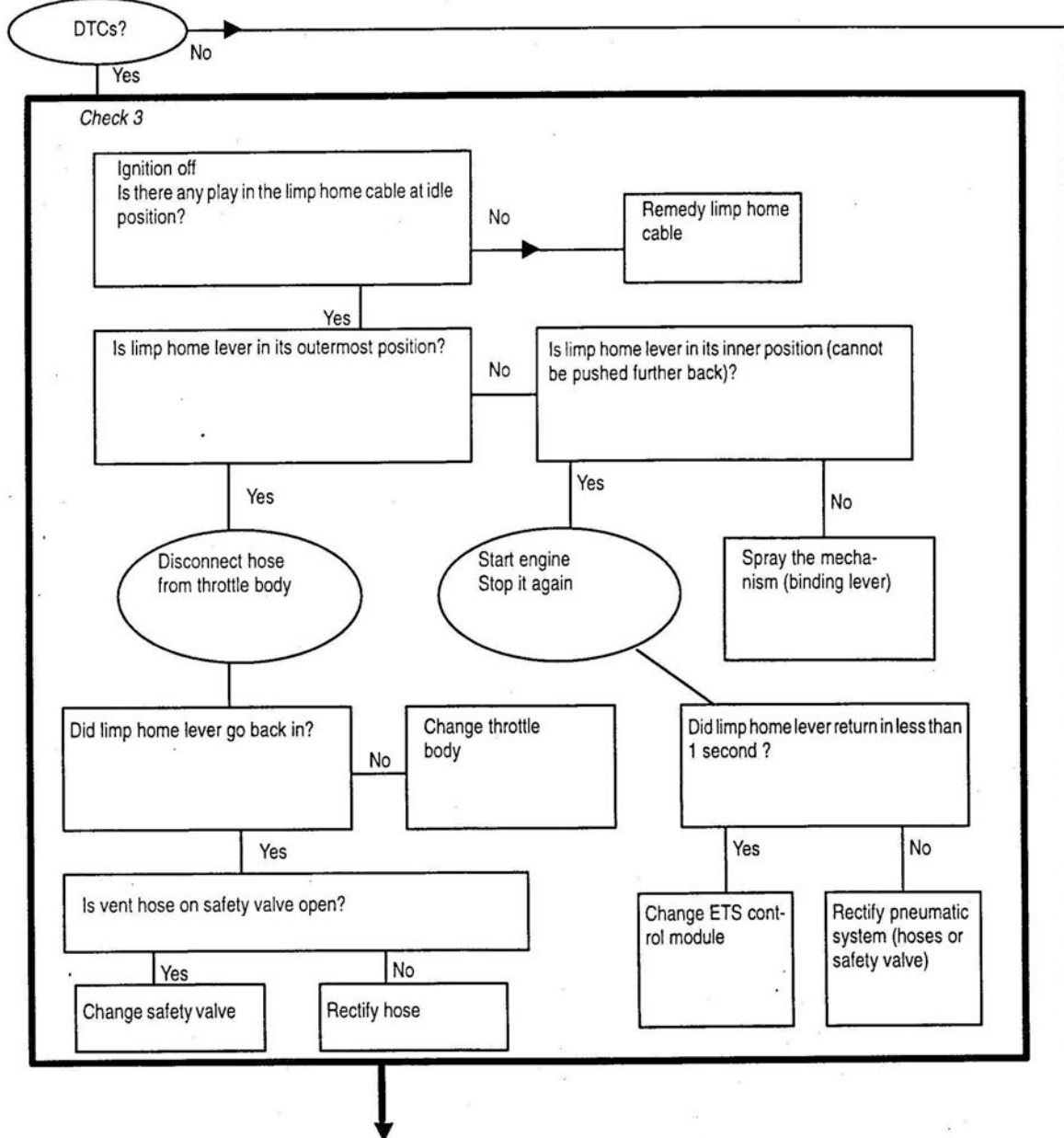
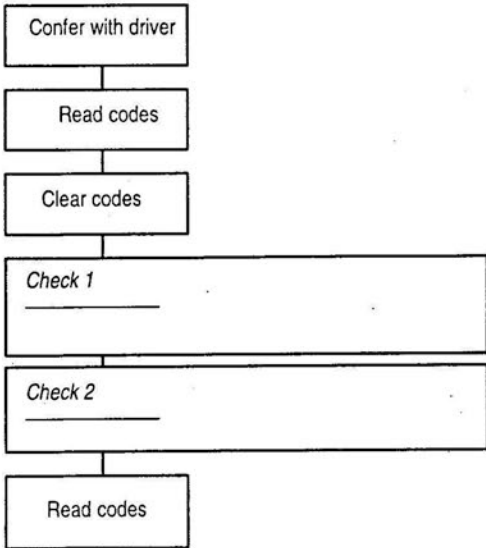



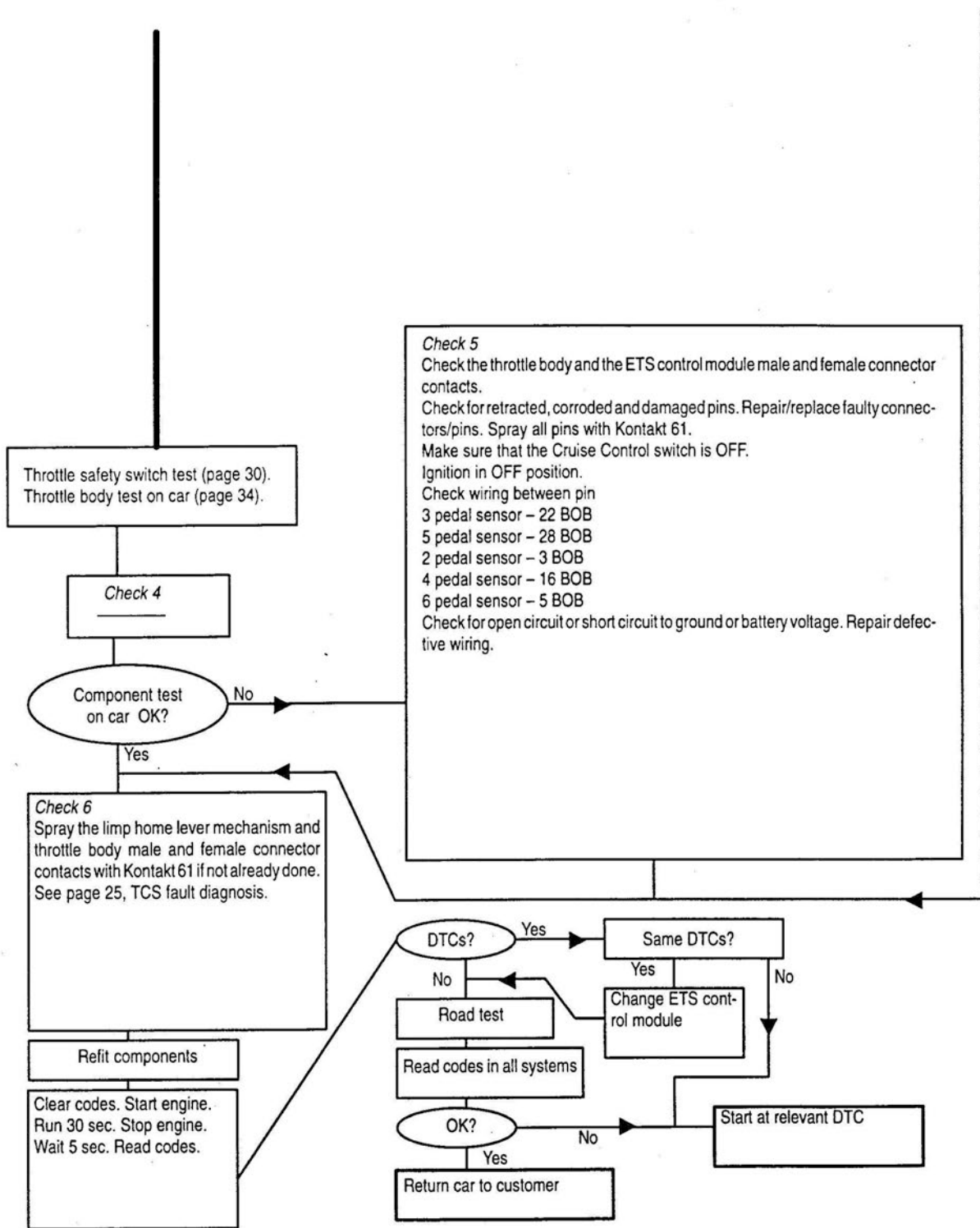

### D/E7591

**Fault info**

ETS cannot open throttle to requested position

**Components**

Pneumatic system (non-return valve, safety valve and hoses).  
Throttle body.

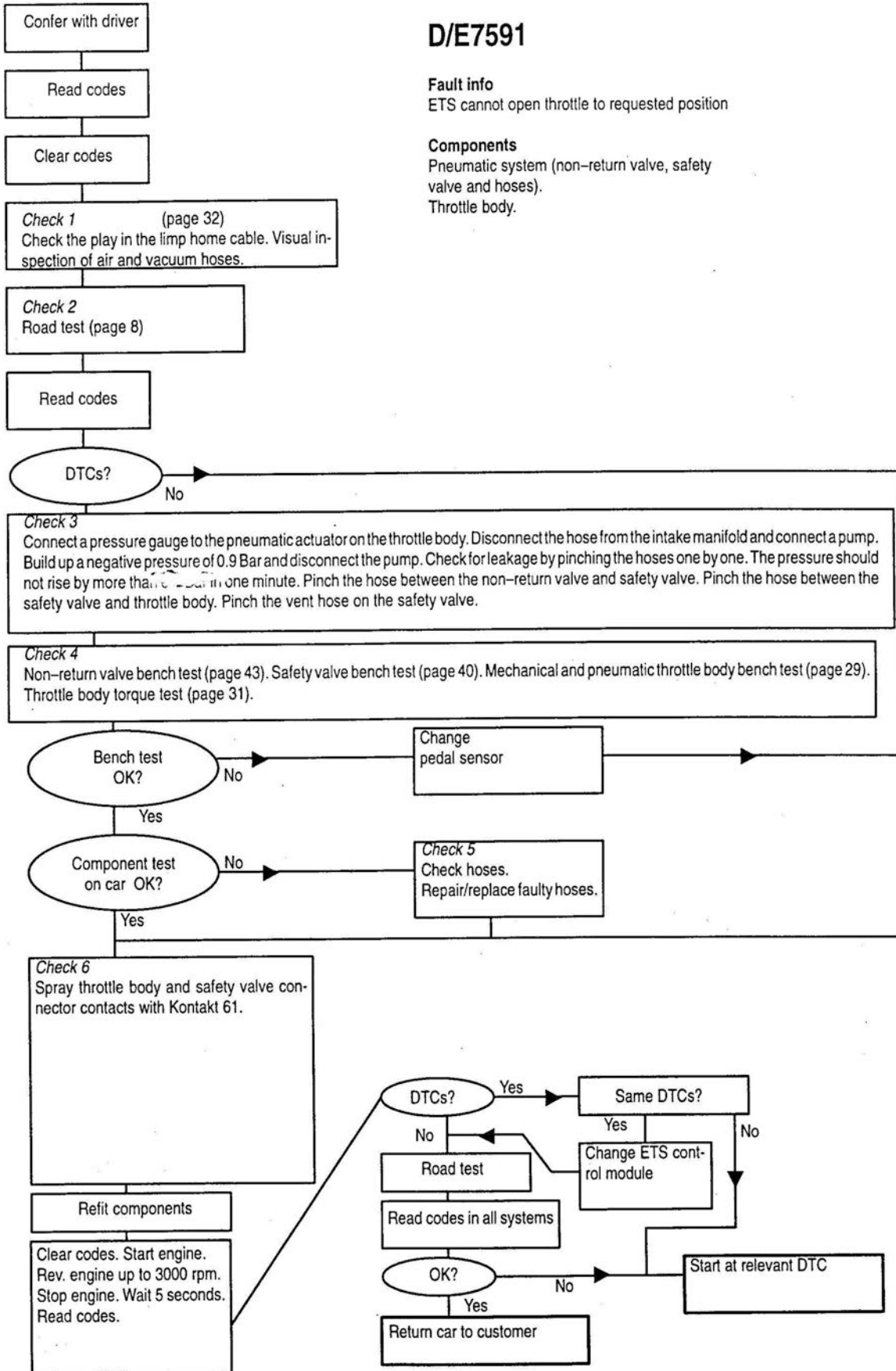

**4/24261**

**Fault info**

Vehicle speed signal incorrect.  
Speedometer signal = 0 but wheelspeed signal from ABS higher than 30 km/h.

**Components**

Speedometer.

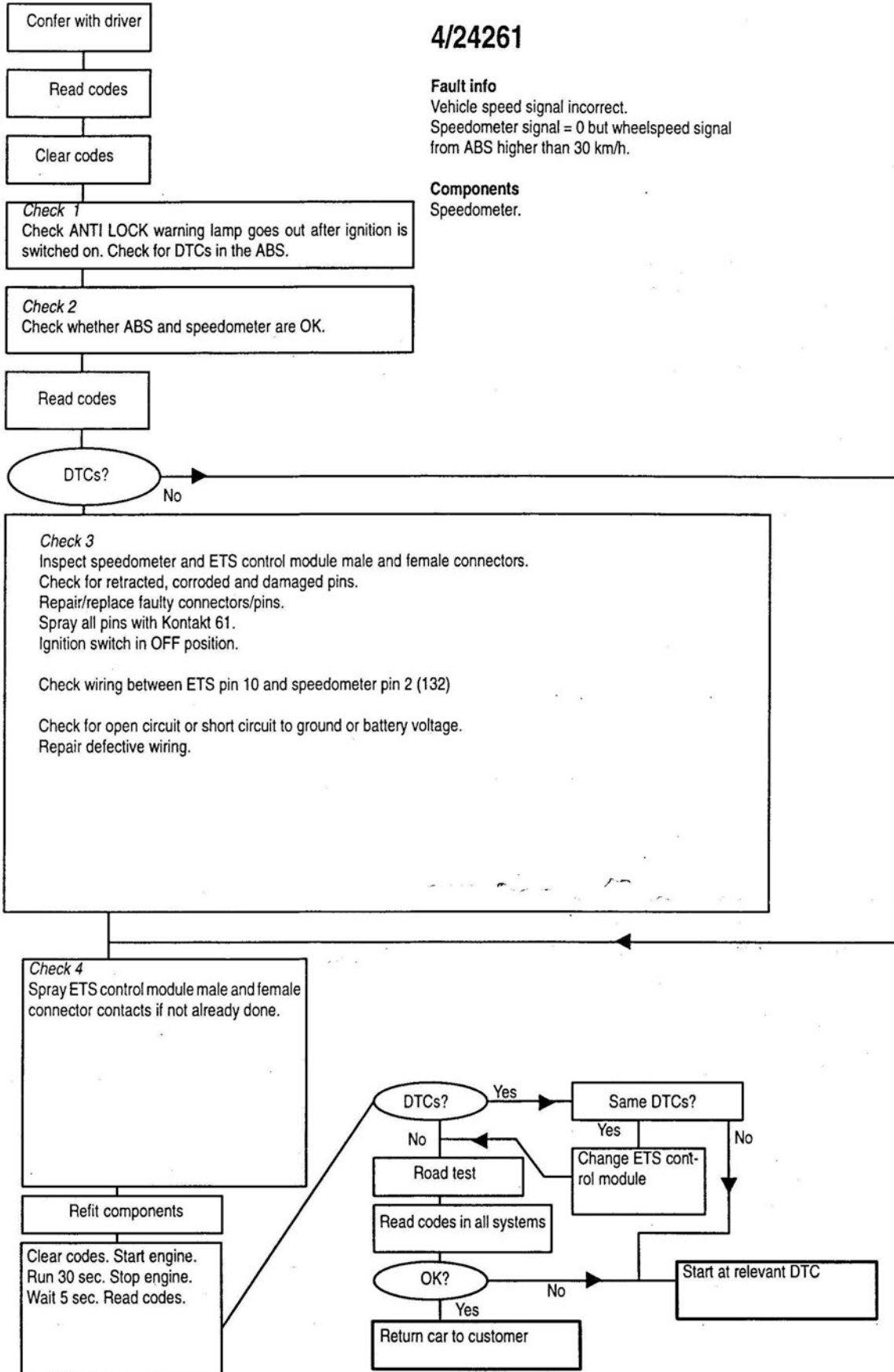

Confer with driver

Read codes

Clear codes

**Check 1**  
Start engine and run it for 10 sec.  
Stop engine.

**Check 2**  
\_\_\_\_\_

Read codes

DTCs?

Yes

No

**Check 3**

If the ANTI LOCK lamp is on, check the ABS first.  
Is the ABS in proper working order?

No → Rectify the ABS

Yes

Inspect the ETS and ABS control module male and female connector contacts. Check for retracted, corroded and damaged pins. Repair/replace faulty connectors/pins.  
Spray all contacts with Kontakt 61.  
Ignition switch in OFF position.

Check wiring between ABS pin  
4 – ETS pin 32  
24 – ETS pin 29

Check for open circuit or short circuit to ground or battery voltage. Repair defective wiring.

**Check 4**  
\_\_\_\_\_

**4/24020, 4021, 4090**

**Fault info**

Information between ETS Control module (pins 32 and 29) and TC/ABS Control module (pins 4 and 24) incorrect.

**Components**

ETS Control module, TC/ABS Control module



### 4/24260

**Fault info**

Vehicle speed signal incorrect.  
Wheel speed signal from ABS = 0 but  
speedometer signal higher than 30 km/h.

**Components**

Speedometer

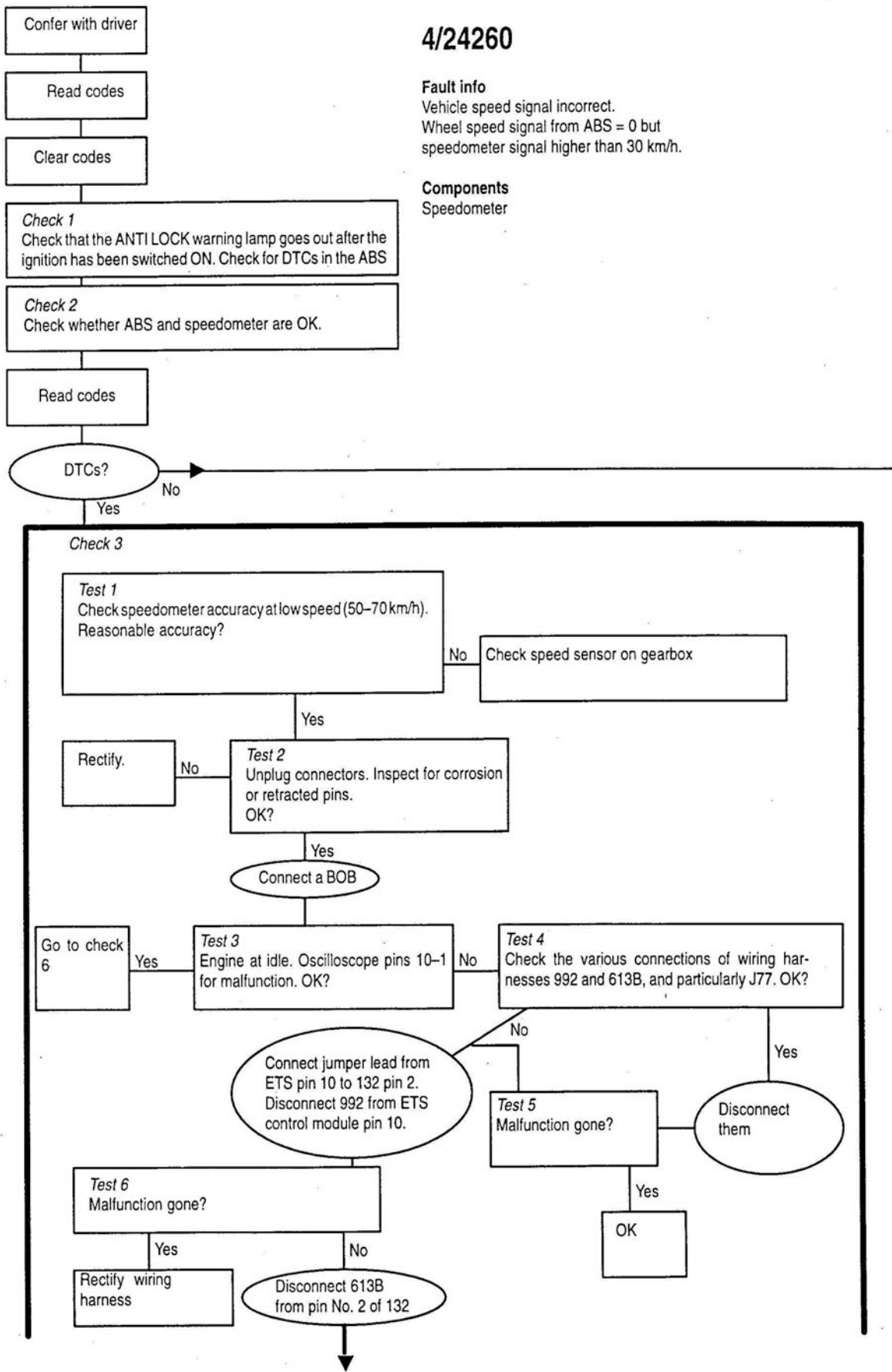

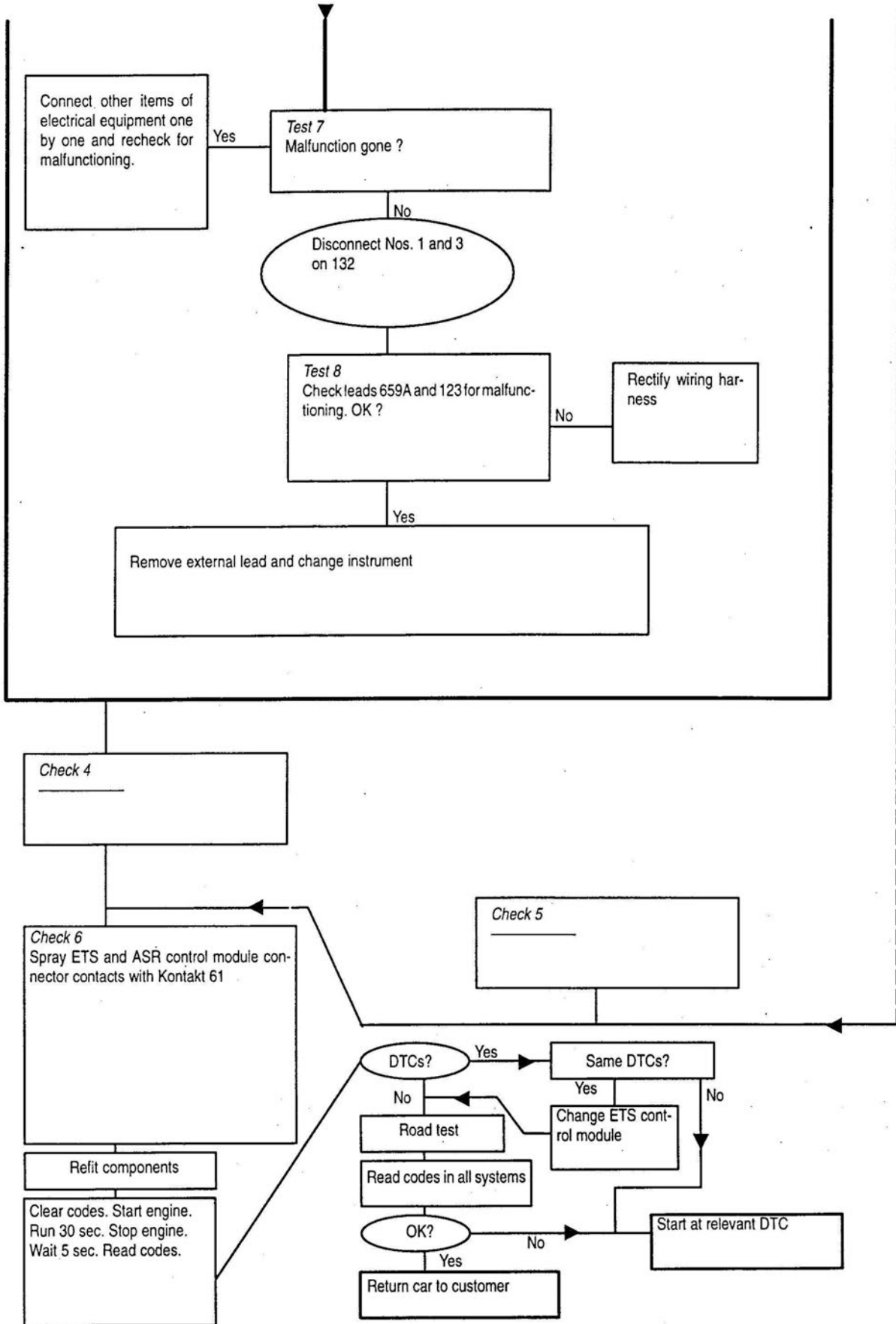

**4/24420**

**Fault info**  
 Engine load signal missing or glitches in engine speed signal.

**Components**  
 ETS control module.

Confer with driver

Read codes

Clear codes

Check 1

Check 2  
 Road test (page 8)

Read codes

DTCs?

No

**Check 3**

Scan tool code 281.  
 Engine running.  
 Reasonable readings?

Yes

Engine switched off.  
 Check for glitches on ETS pin 12  
 (engine speed signal) using oscil-  
 loscope. Glitches on engine speed  
 signal?

No

Go to check 6

No

Rectify

Unplug connectors on ETS and  
 engine management system. In-  
 spect for corrosion or retracted  
 pins. OK ?

Yes

Check leads 706A, 706, 530 and  
 J65 and their various connections.

No

No

Rectify

Check the wiring between ETS pin  
 27 and Trionic pin 35 (LH pin 25, DI  
 pin 36). Check for an open circuit or  
 short circuit to ground or battery  
 voltage. OK ?

No

Yes

Disconnect them.  
 Glitches gone?

Yes

OK



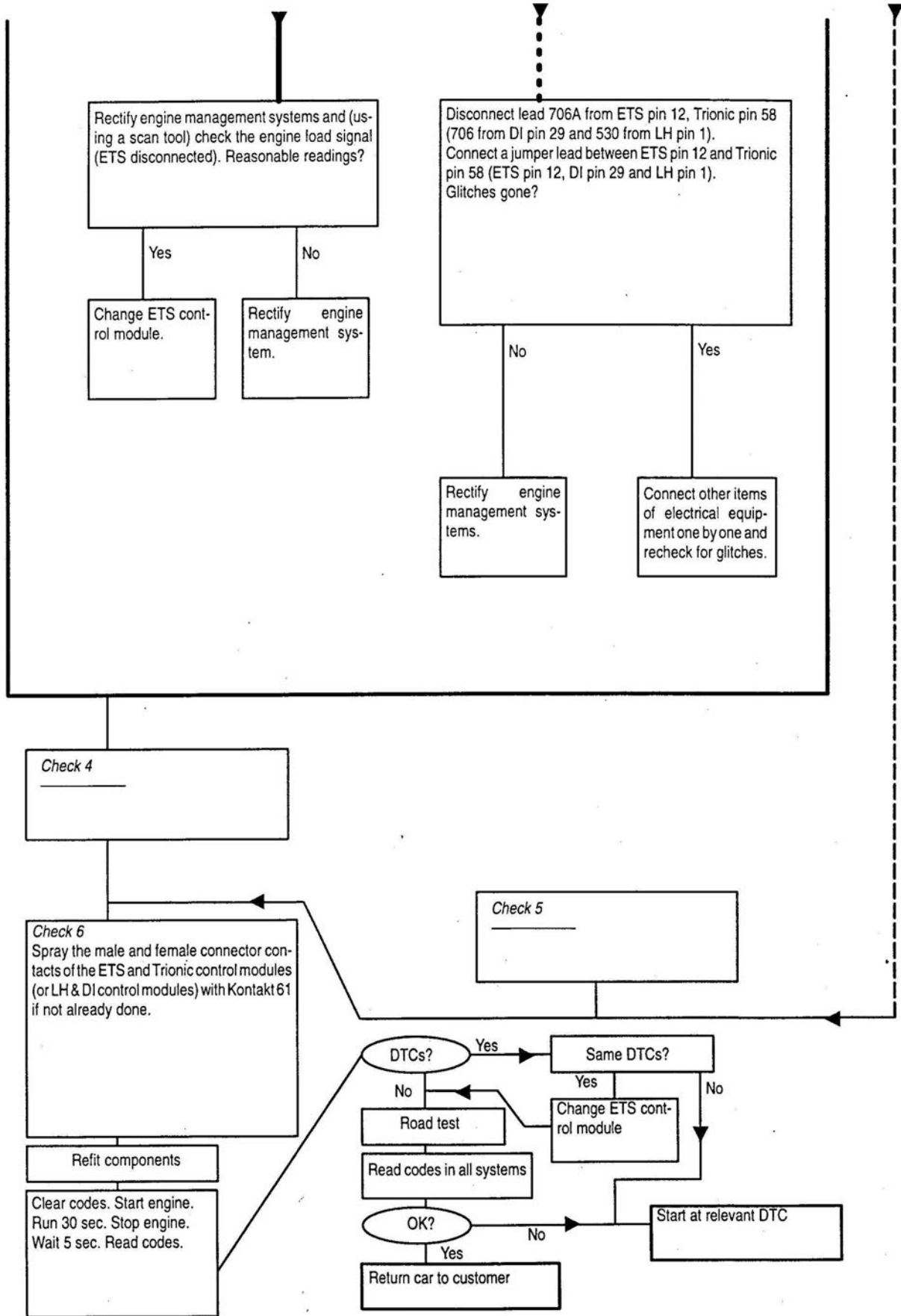

**4/24690**

**Fault info**  
 Discrepancy between the engine load signal (Tq) and the engine speed signal (Td).

**Components**  
 Engine management system.

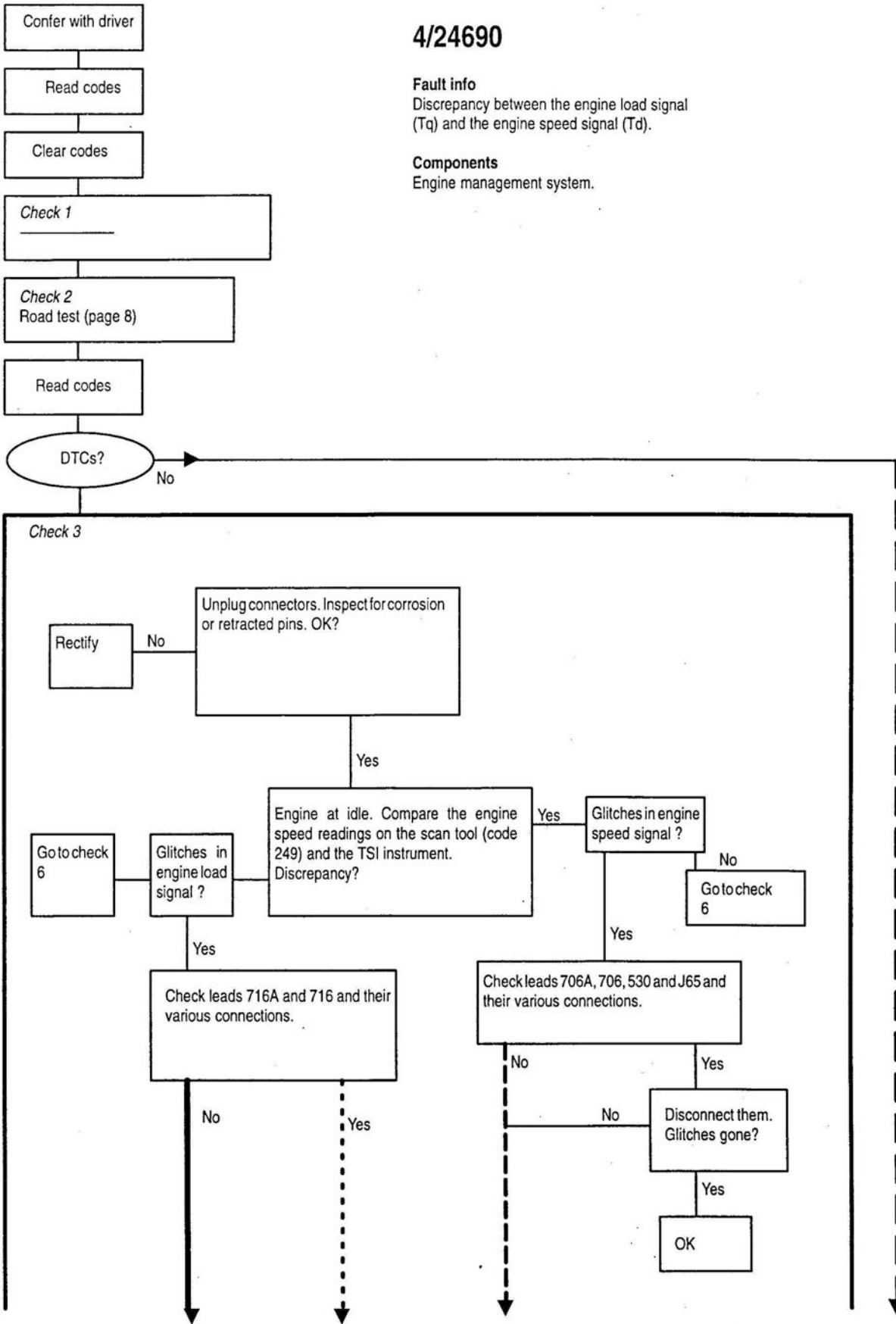

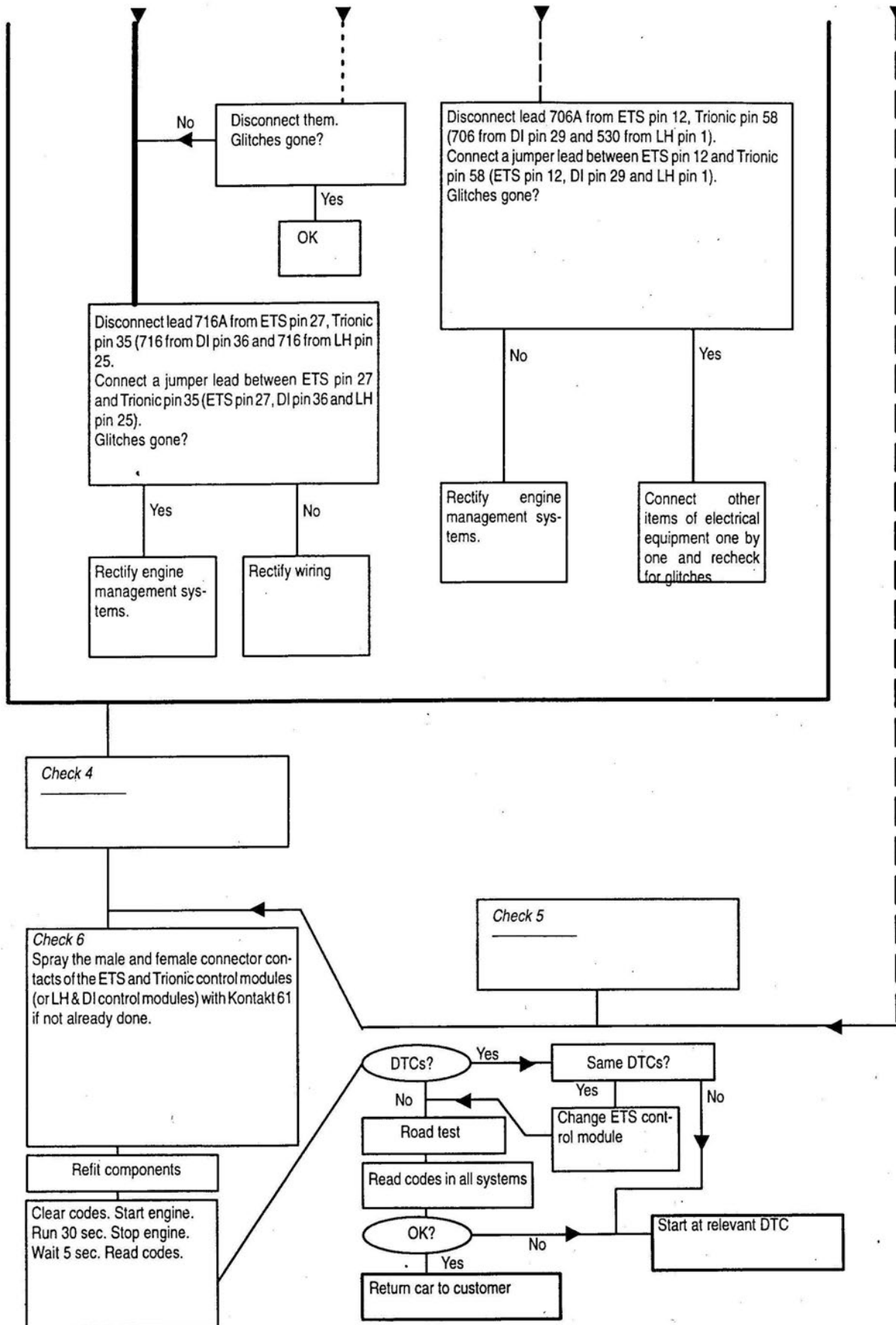

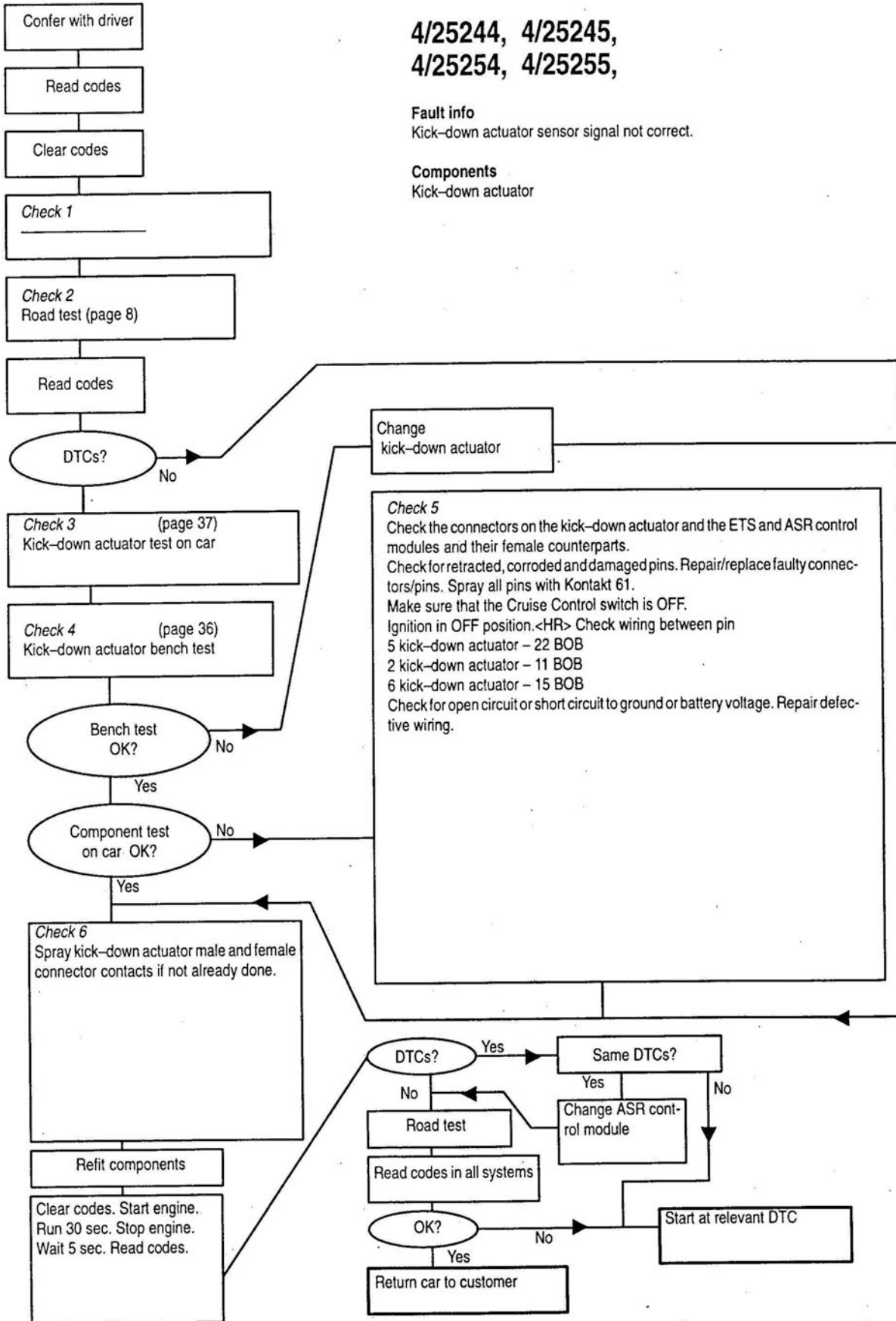

**4/25244, 4/25245,  
4/25254, 4/25255,**

**Fault info**  
Kick-down actuator sensor signal not correct.

**Components**  
Kick-down actuator

**6/783B0**

**Fault info**  
Oscillating throttle sensor signal.

**Components**  
Throttle body

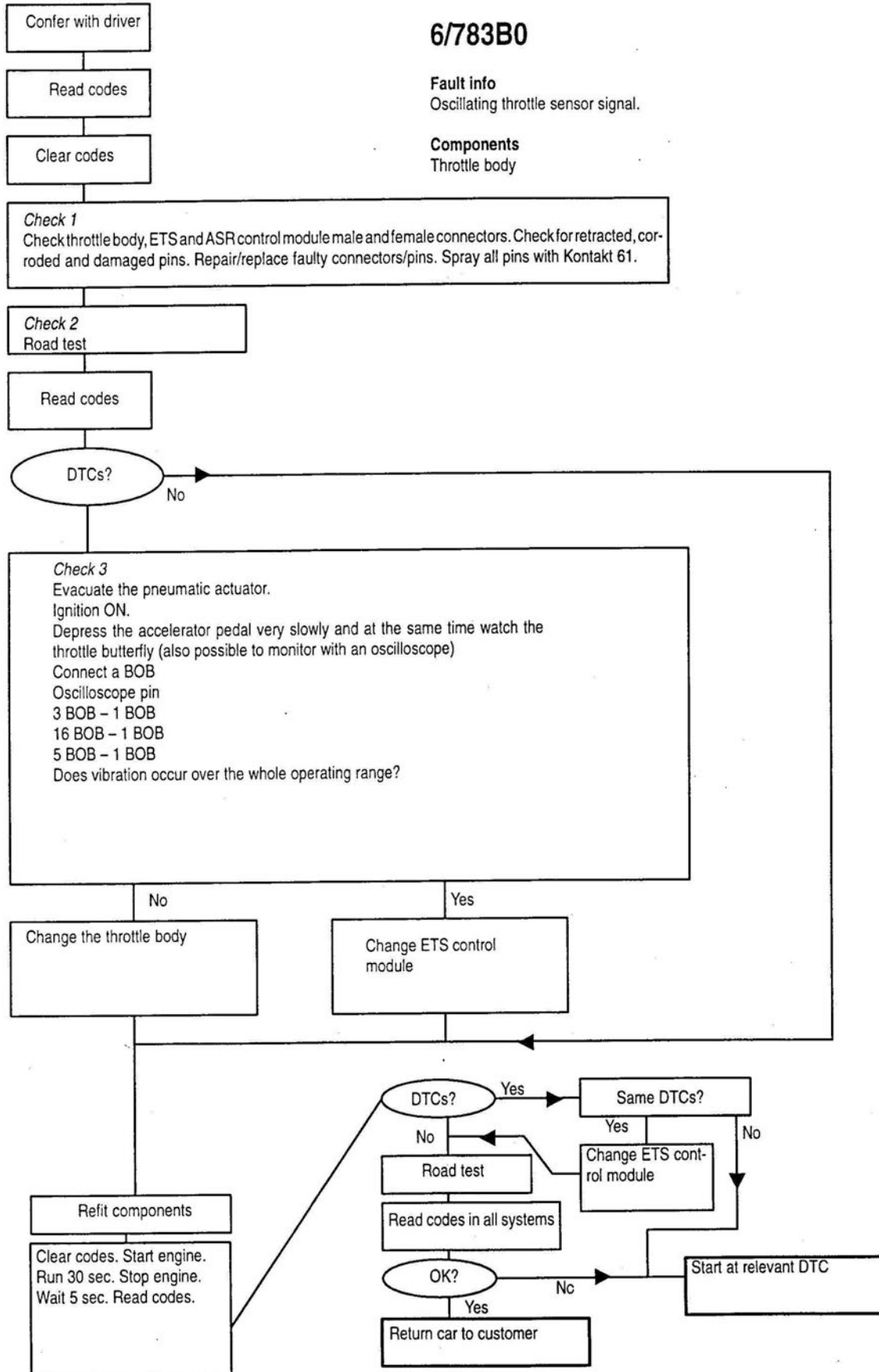

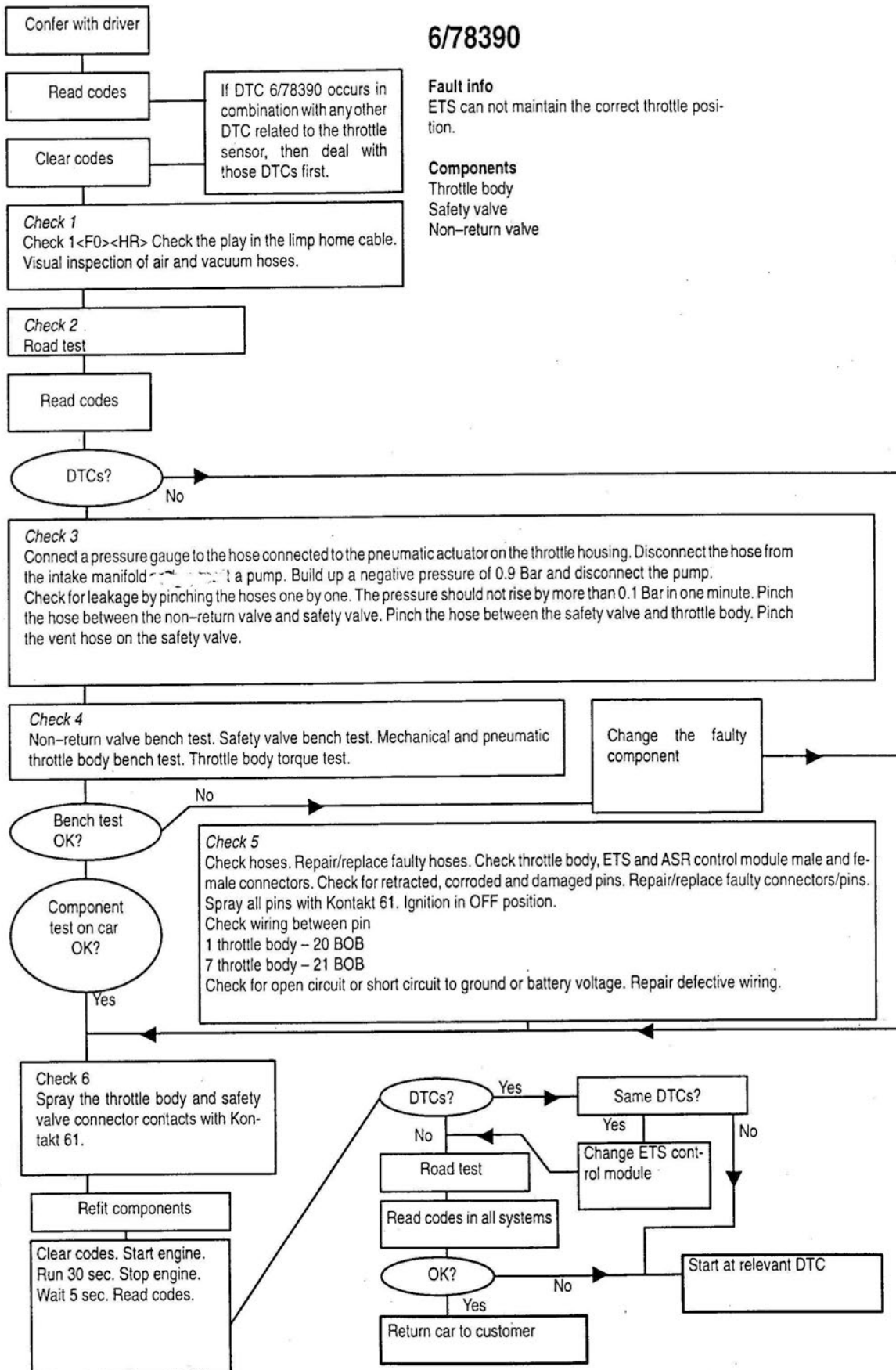

## ETS reference charts

There are no graphs for vacant pins Nos. 8, 11, 24 and 30.

Sometimes more than one graph is presented for a particular pin, due to different situations (different states of a switch for example). In such cases the graphs will have an index letter (a, b, c...).

Normally the graphs are produced with the IGNITION ON. If the engine has to be running, it will be specially noted.

### Oscilloscope channel configuration

CH1 = Main ground control module (ref. point)

CH2 = Main signal

CH3 = Related signal

CH4 = Specially required signal

### Pin 1—Main ground control module

For pin 1 (CH2) the reference point is G7 (CH1).

#### Note

The dashed line and double arrow on each graph are reference marks to help you interpret the traces produced. Along the top of each graph are the channel (CH), the voltage at the double arrow and the time difference between the dashed line and double arrow.

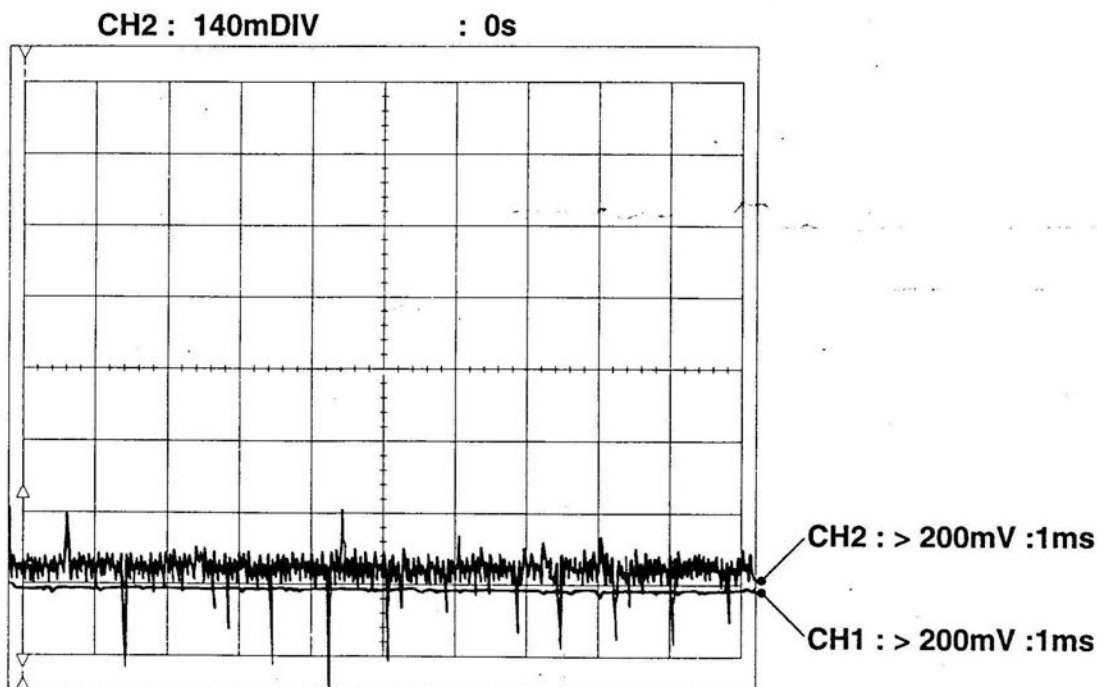

### Pin 2 — Accelerator pedal position sensor (+)

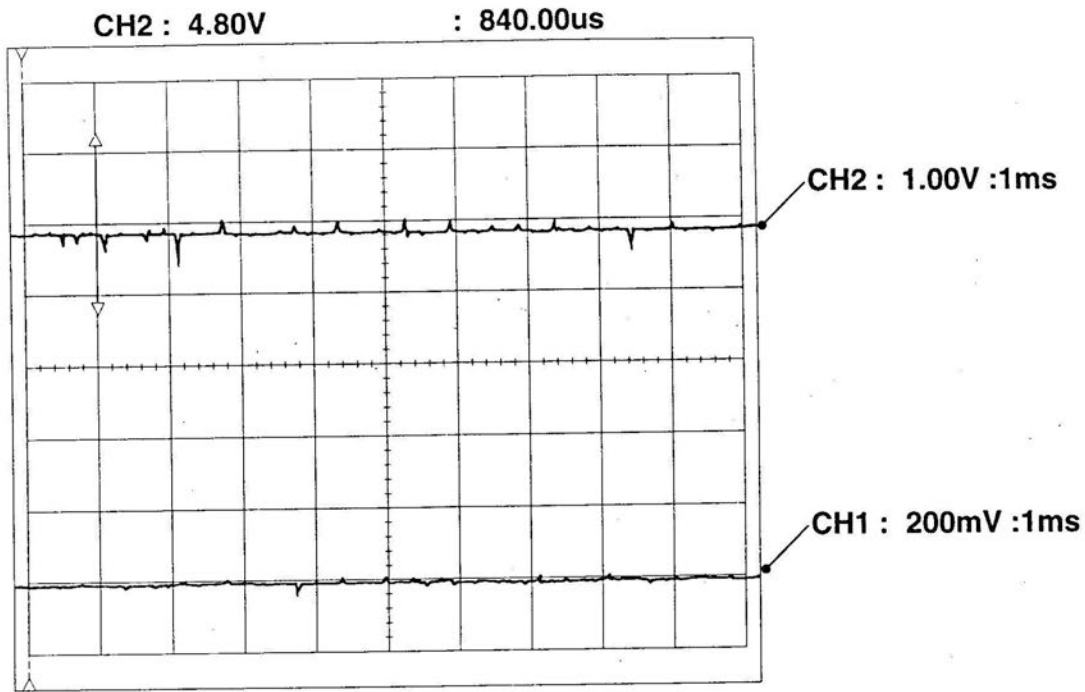

C271W-5506

### Pin 2a — Accelerator pedal position sensor (+/-)

CH2 = (+)  
CH3 = (-)

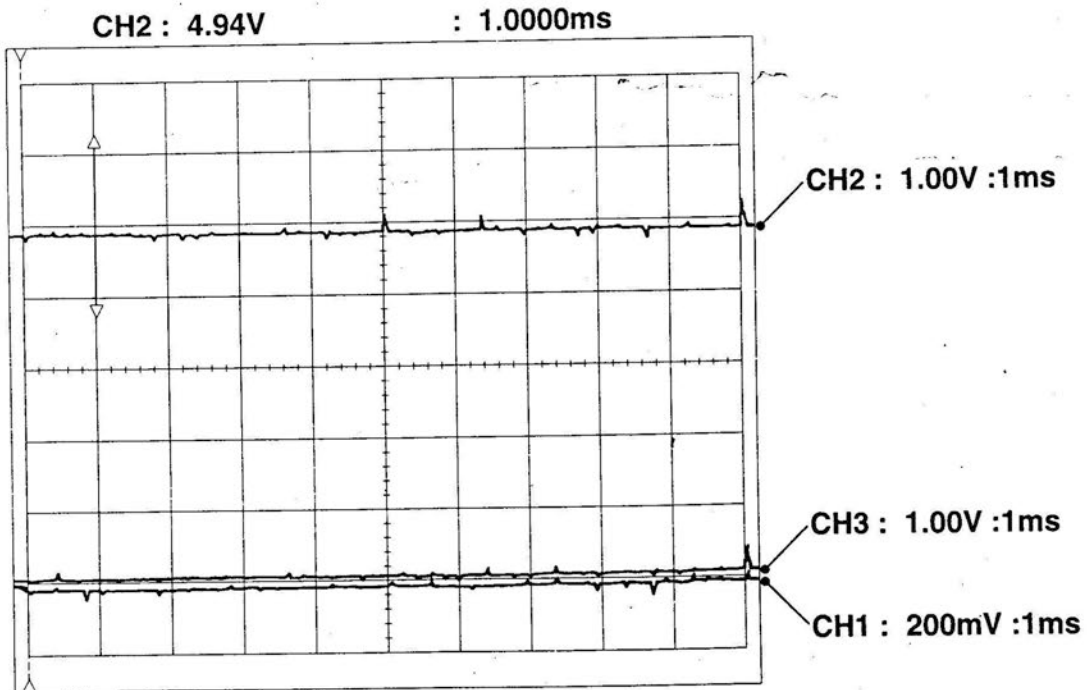

C271W-5508



### Pin 3 — Throttle position sensor (+)

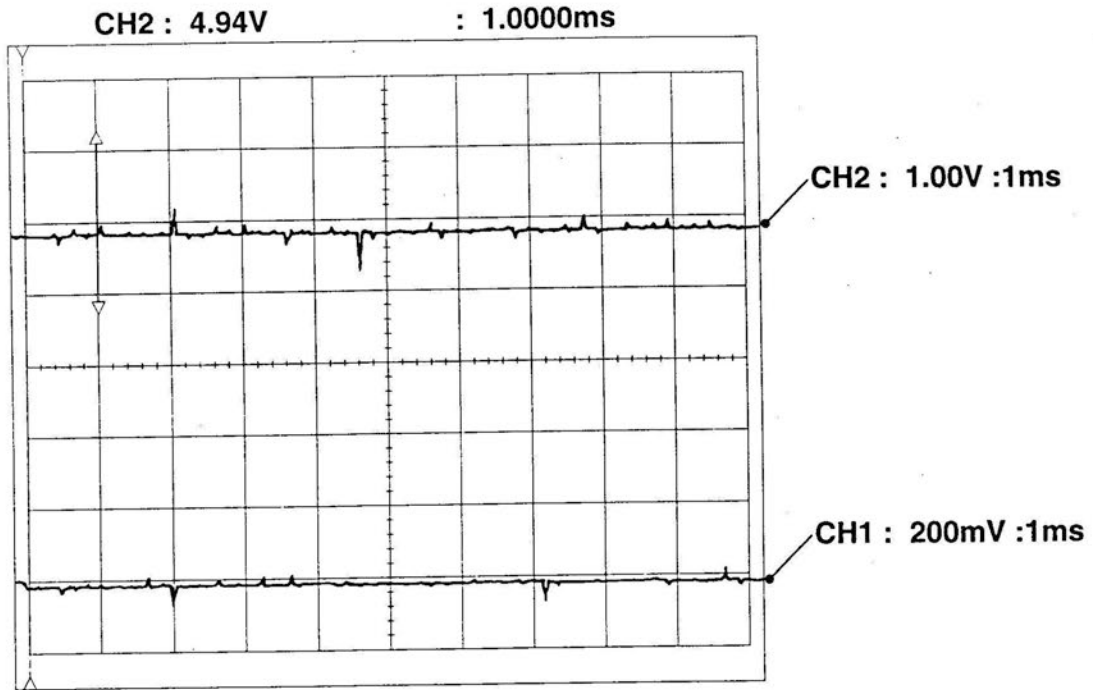

C271W-5509

### Pin 3a — Throttle position sensor (+/-)

CH2 = (+)  
CH3 = (-)

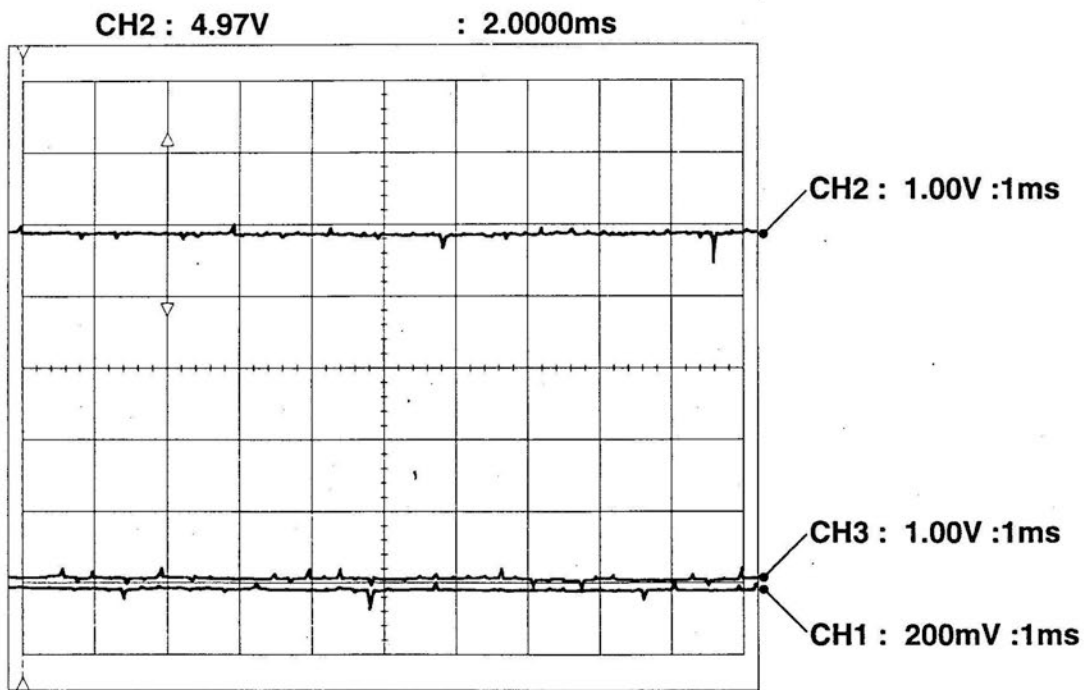

C271W-5510

### Pin 4 — Accelerator pedal position sensor (-)

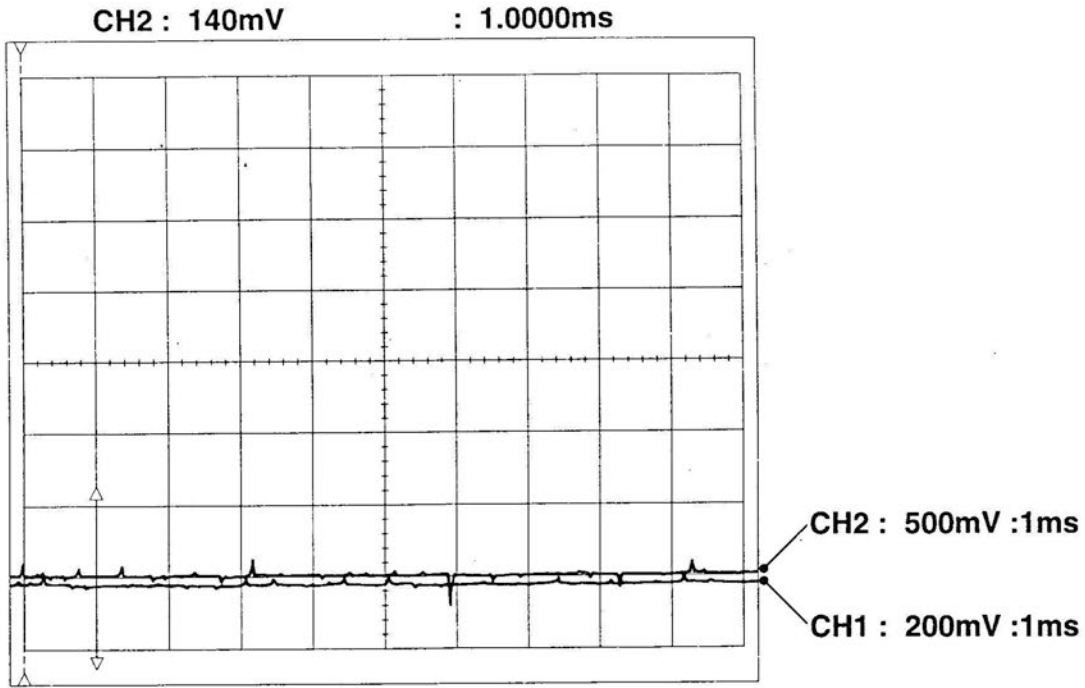

### Pin 4a — Accelerator pedal position sensor (+/-)

CH2 = (+)  
CH3 = (-)

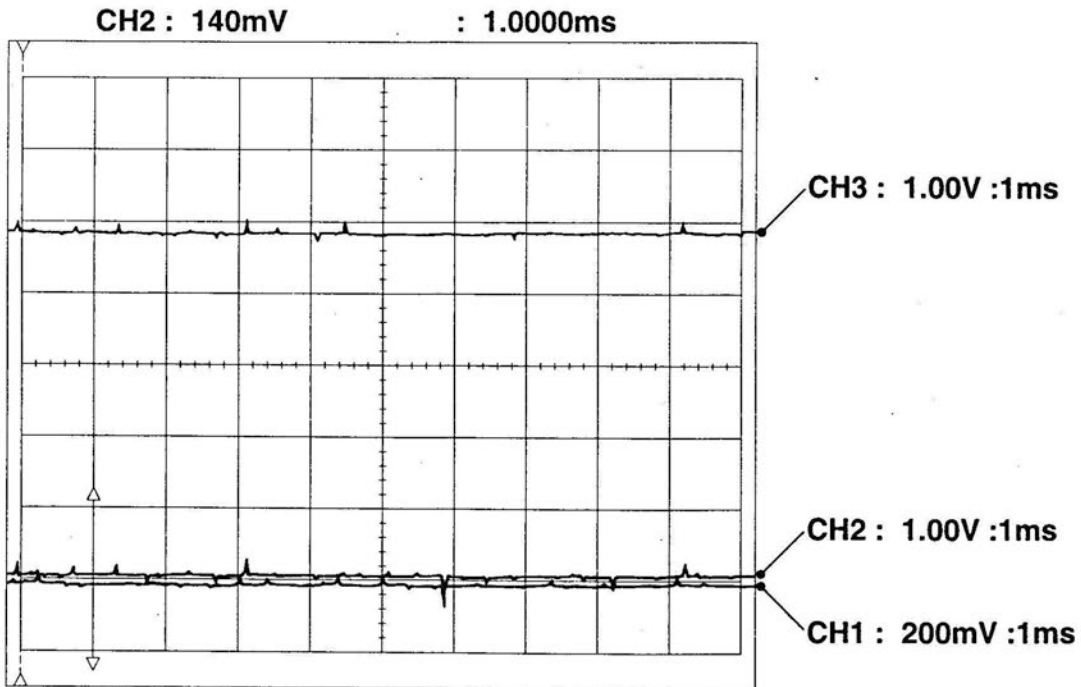

### Pin 5 — Throttle position sensor (-)

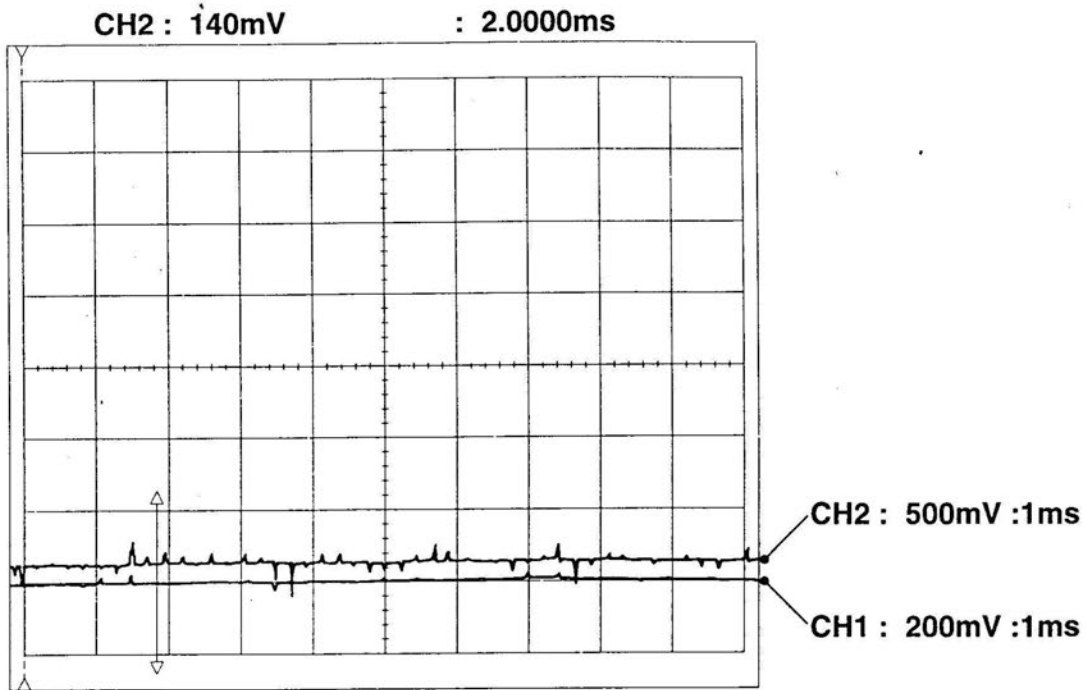

C271W-5513

### Pin 5a — Throttle position sensor (-/+)

CH2 = (-)  
CH3 = (+)

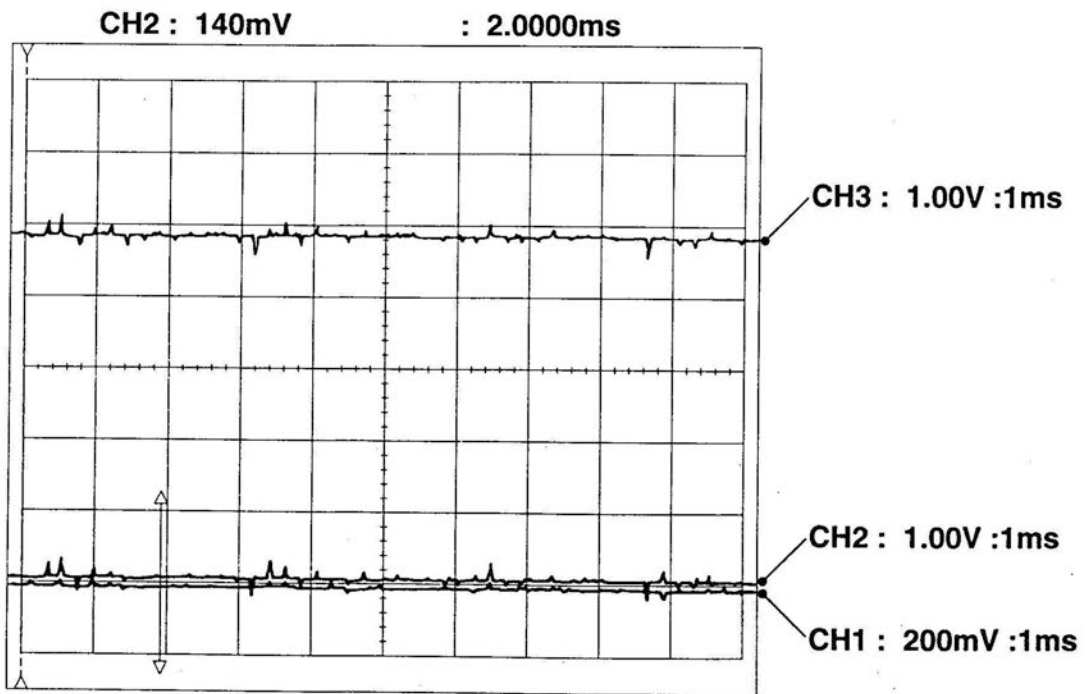

C271W-5514

### Pin 6 — (Charge air bypass) control valve

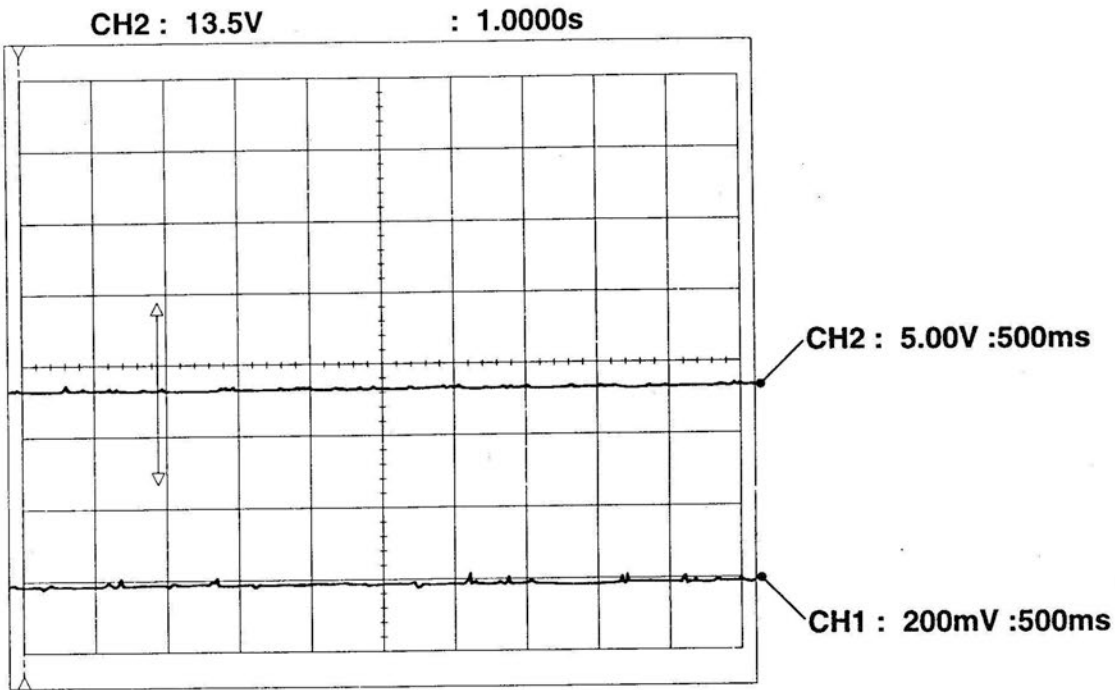

### Pin 6a — (Charge air bypass) control valve (pulsed)

Note: Use scan tool code 552 ► pulse 1 Hz

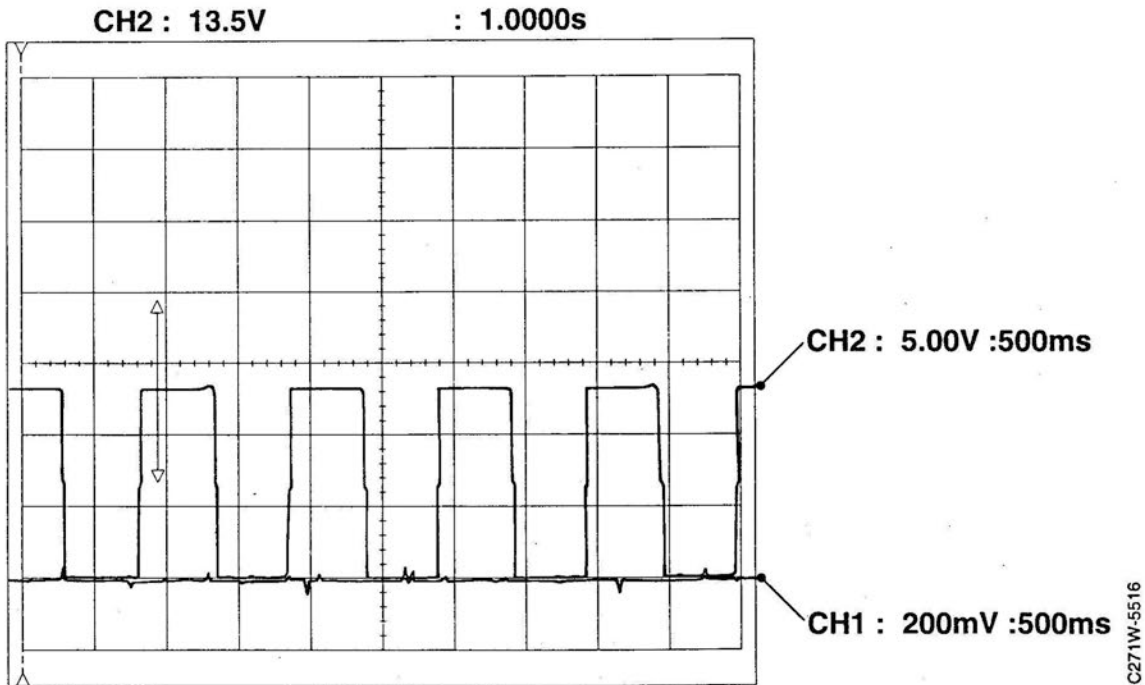

### Pin 7 — ETS control module main ground (not used)

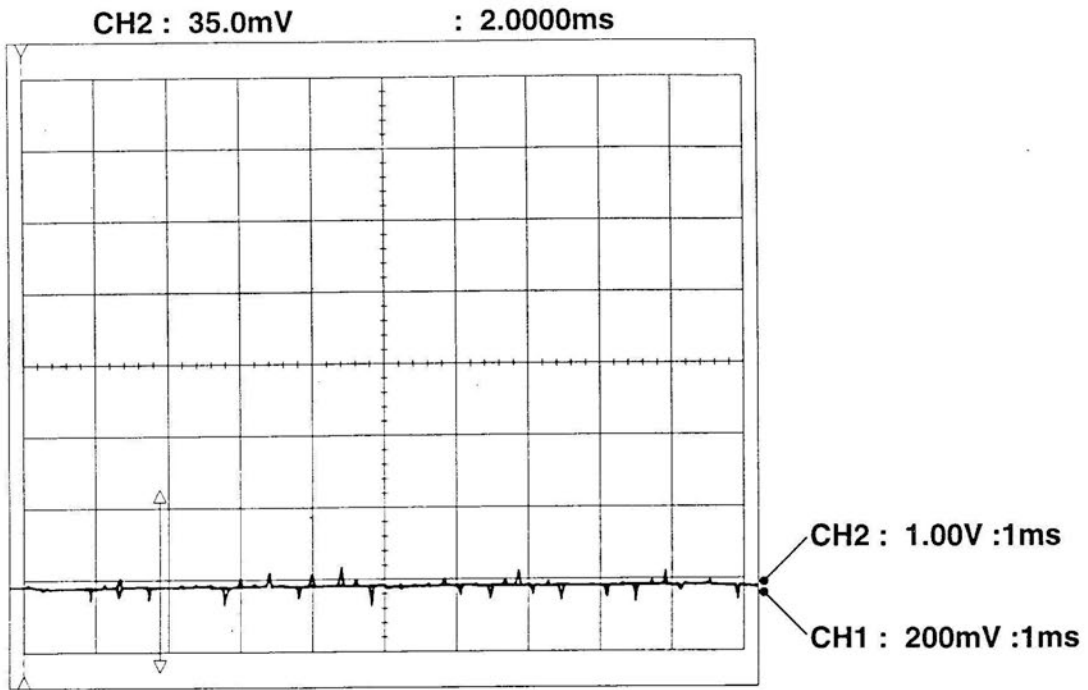

### Pin 9 — Scan tool communication L-line

Note: No diagnostics

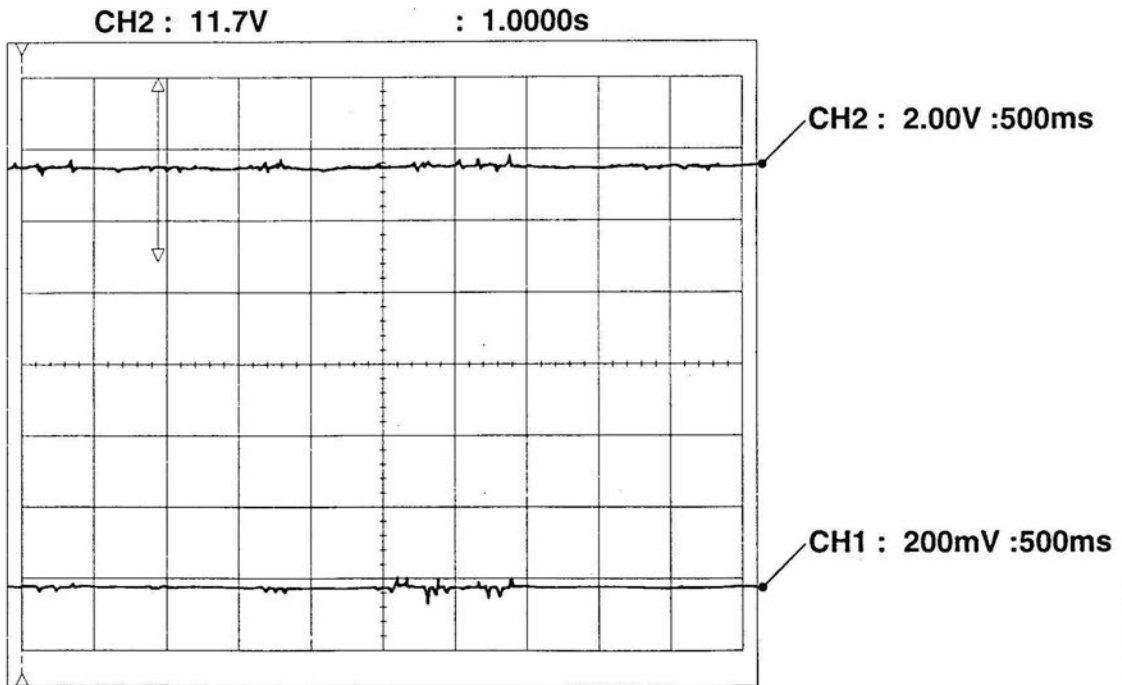

### Pin 9a — Scan tool communication L-line

Note: when init. system No. 3, also see pin 34

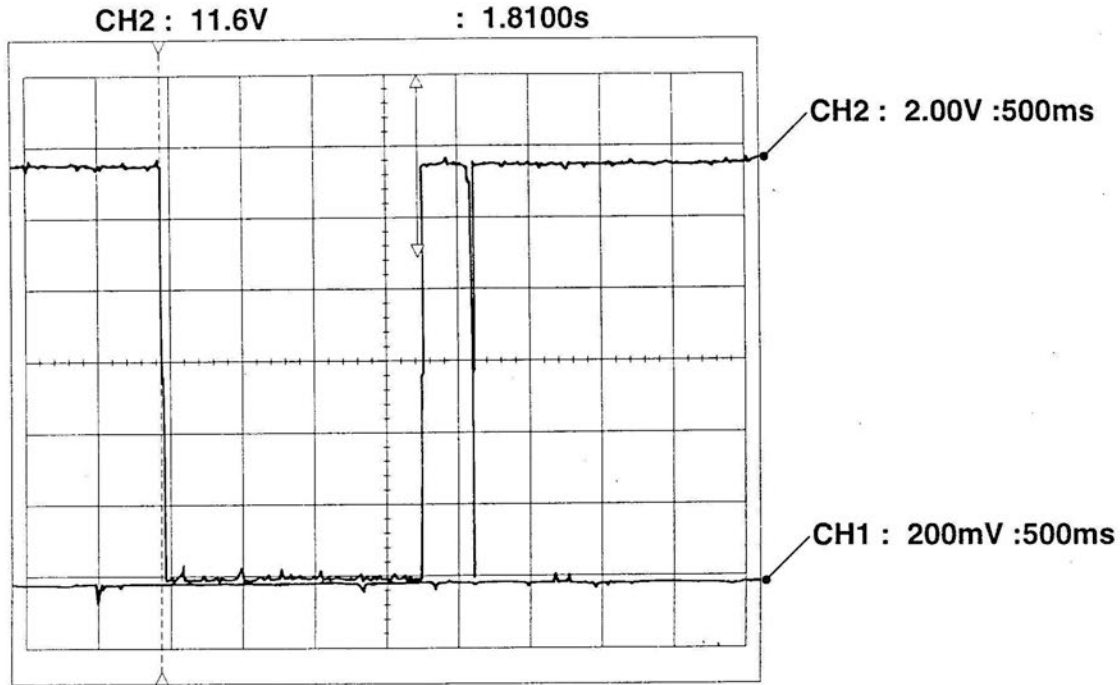

### Pin 9b — Scan tool communication L/K-line

Note: when init. system No. 3, also see pin 34

CH2 = L-line (refer to 9a)

CH3 = K-line

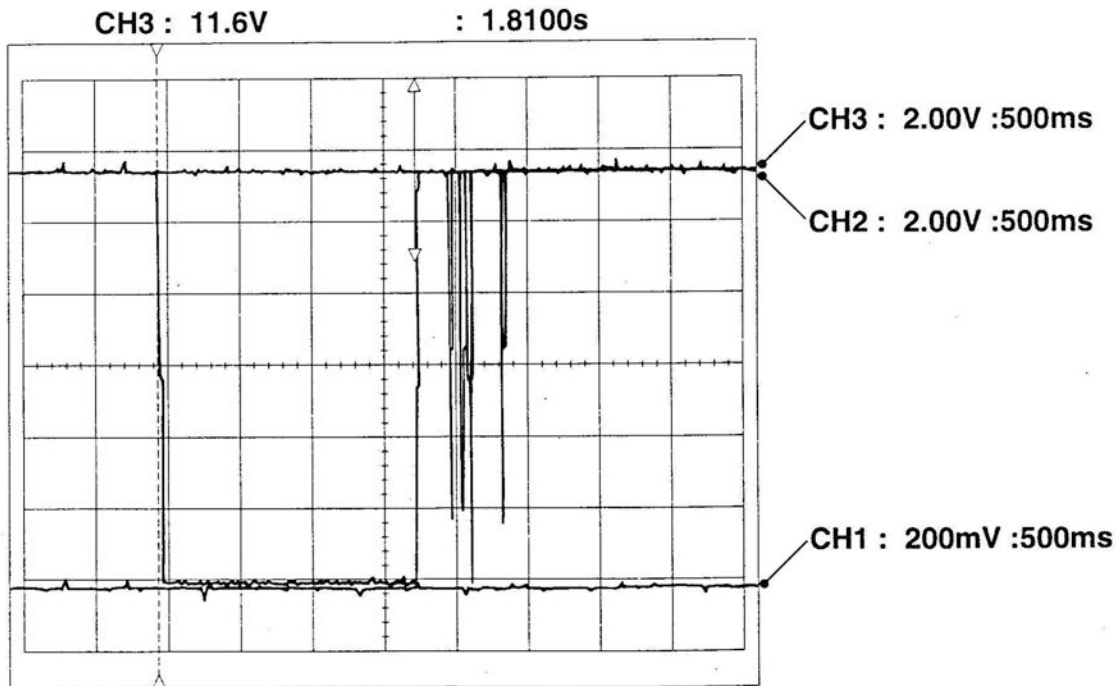

### Pin 10 — Vehicle speed (20 km/h)

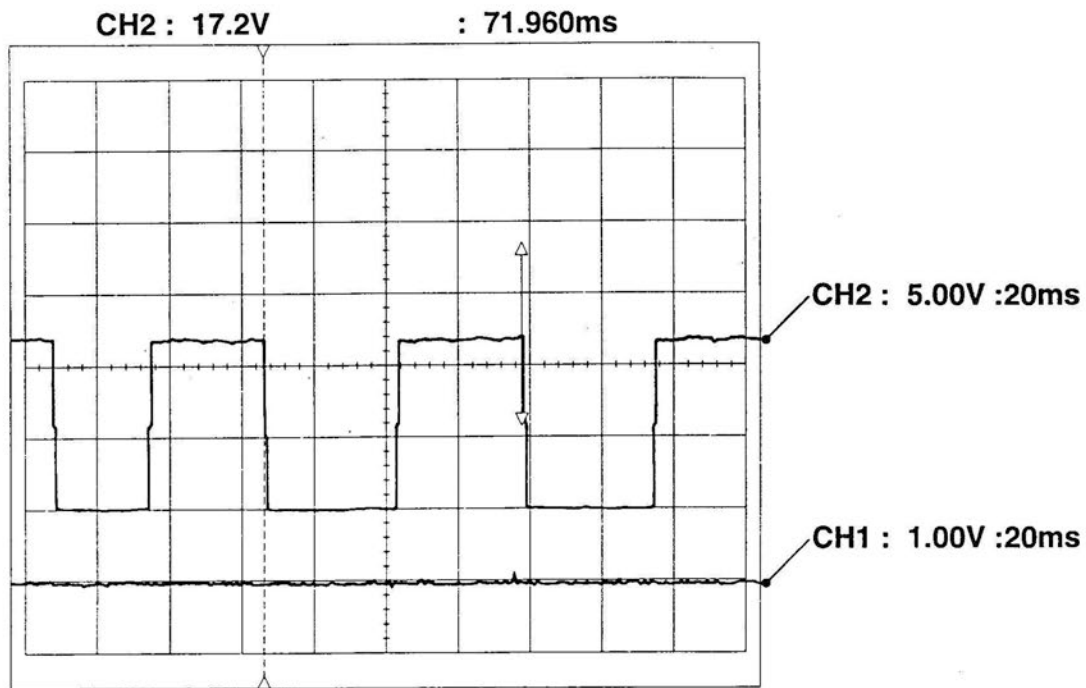

### Pin 10a — Vehicle speed (100 km/h)

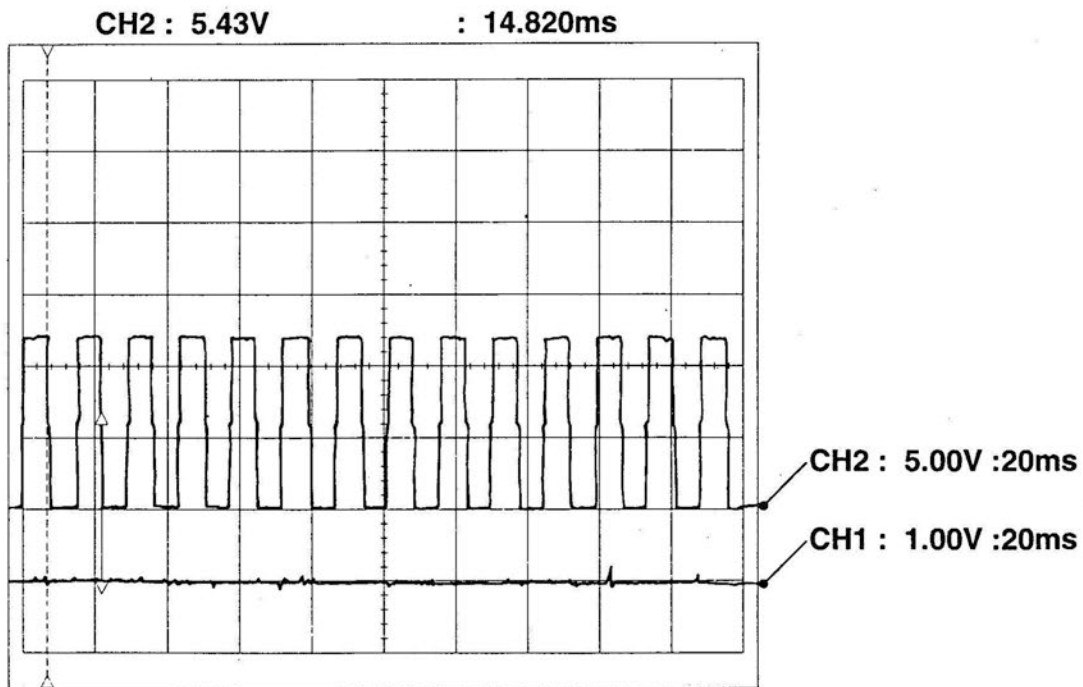

### Pin 12 — Engine speed ( $\approx$ 850 rpm)

Note: engine running, Trionic cars only

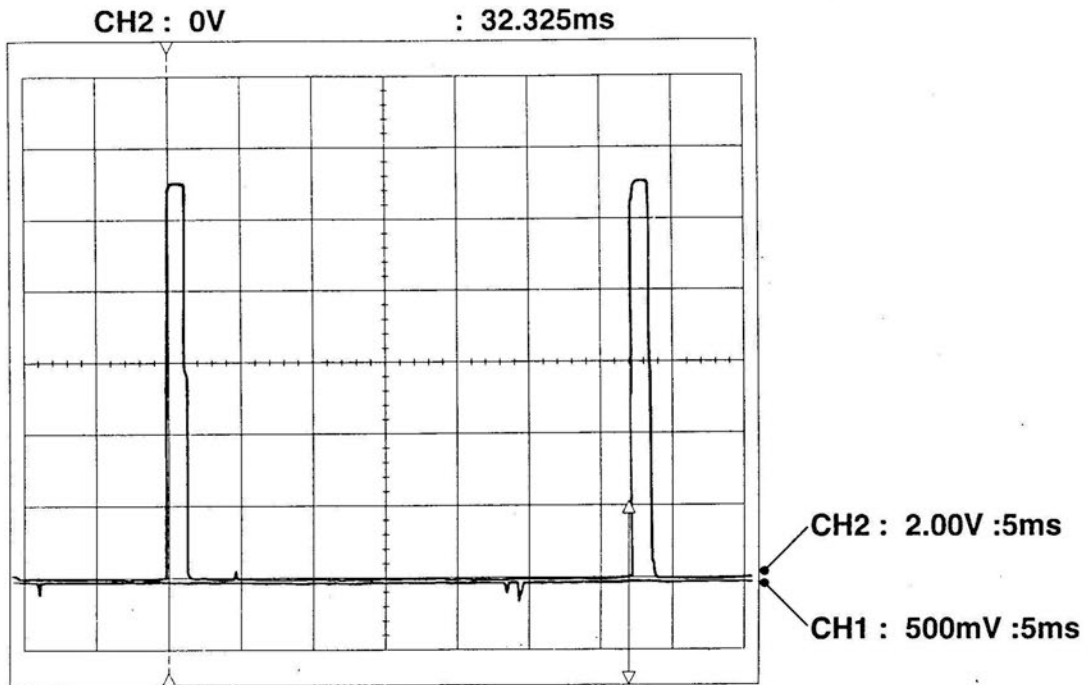

### Pin 12a — Engine speed ( $\approx$ 2000 rpm)

Note: engine running, TRIONIC cars only

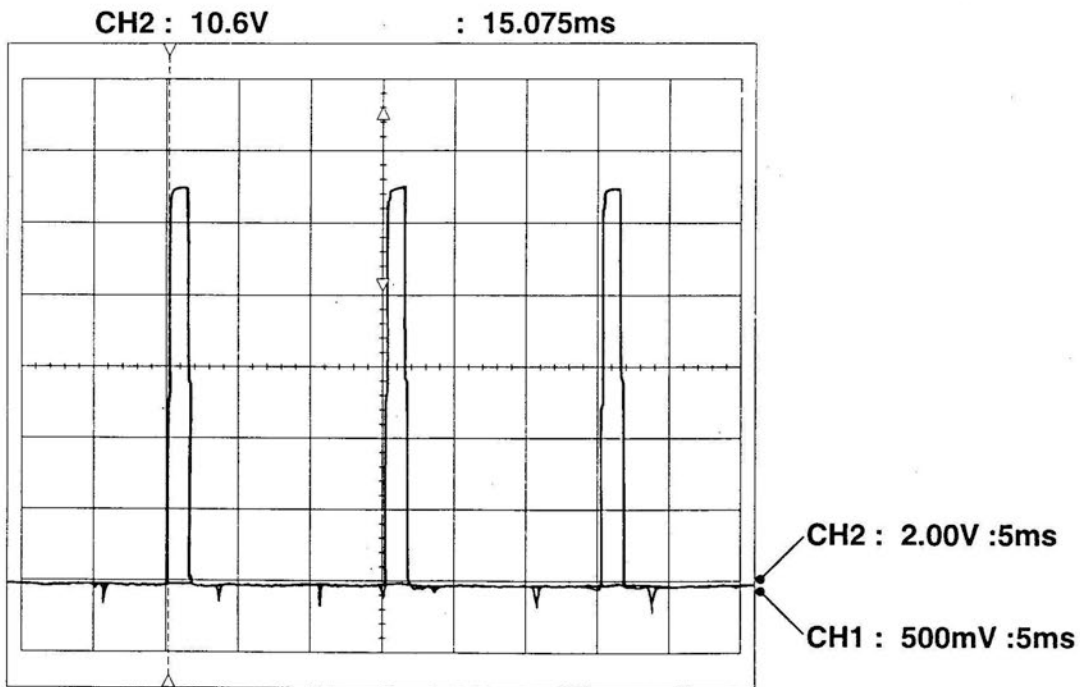



### Pin 12b — Engine speed ( ≈ 3000 rpm)

Note: engine running, Trionic cars only

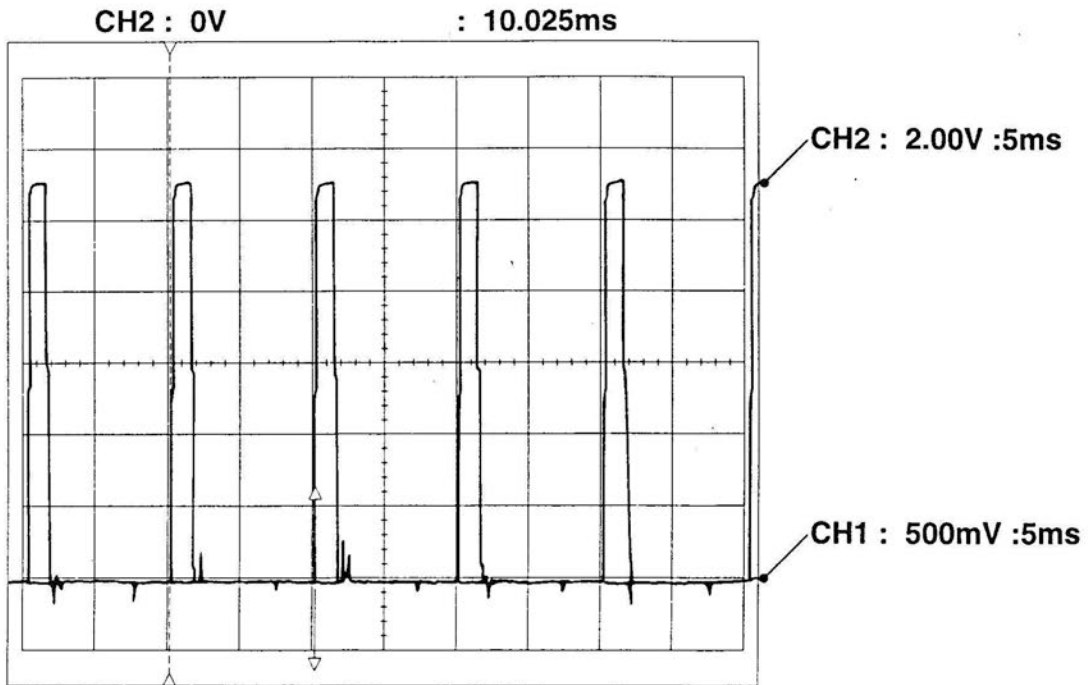

### Pin 13 — Main relay (ignition ON)

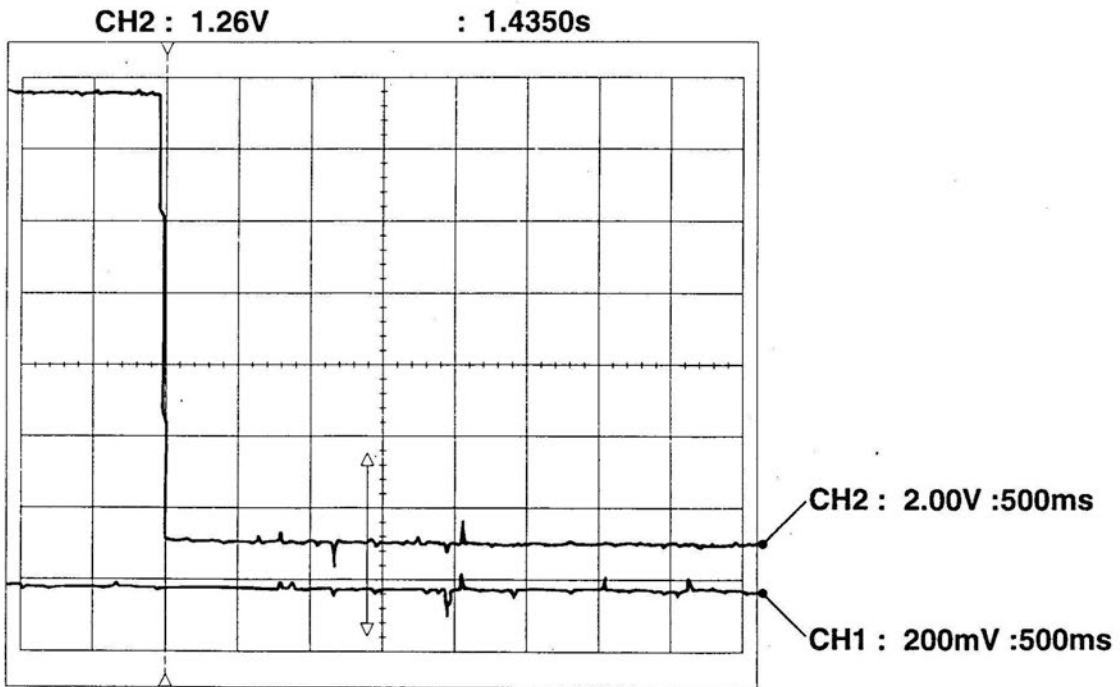

### Pin 13a — Main relay (ignition OFF)

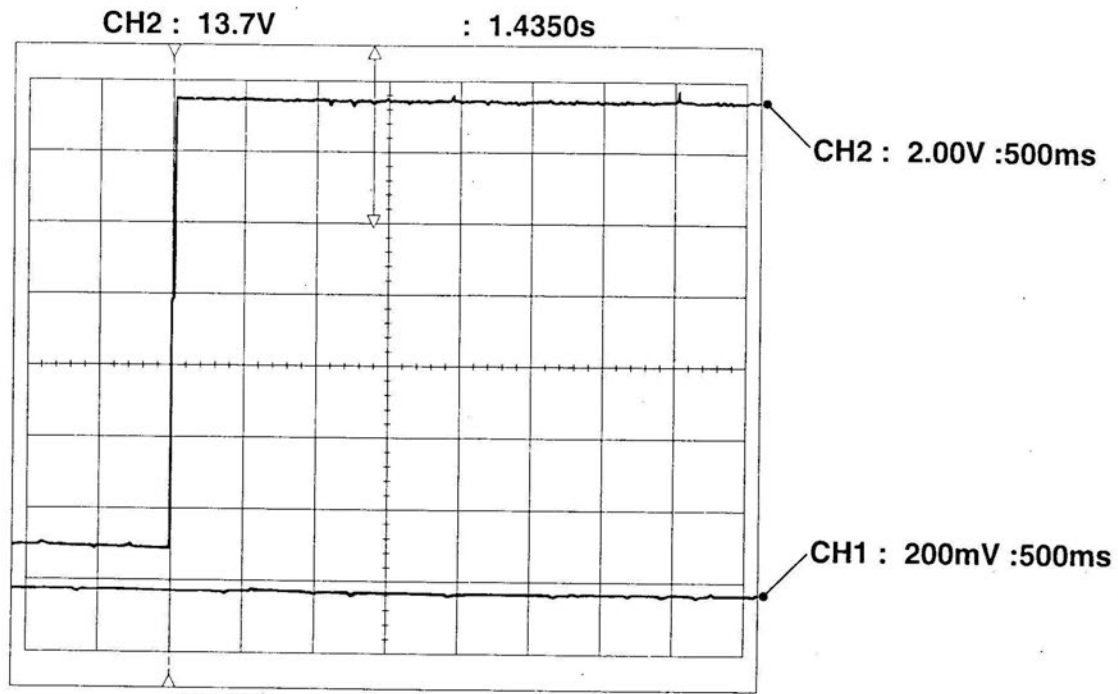

C271W-5627

### Pin 14 — Accelerator pedal safety switch

Note: released ► depressed ► released  
 Compare with scan tool code 207

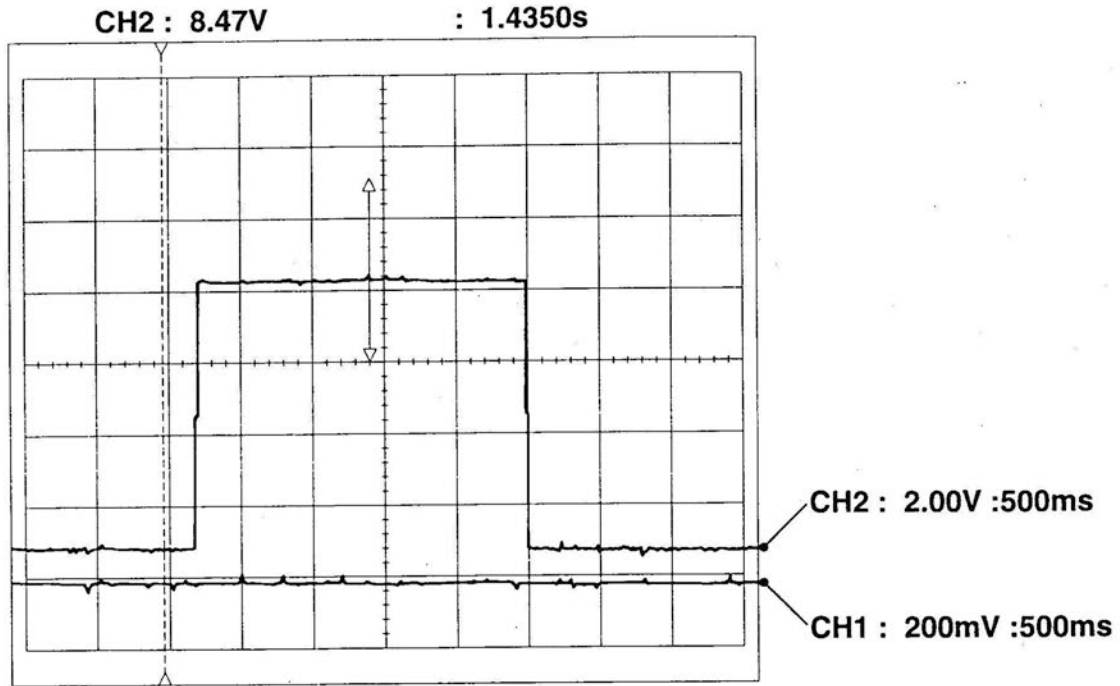

### Pin 14a — Accelerator pedal safety switch

Note: CH2 = Accelerator pedal safety switch  
 CH3 = throttle housing safety switch  
 CH4 = Accelerator pedal position

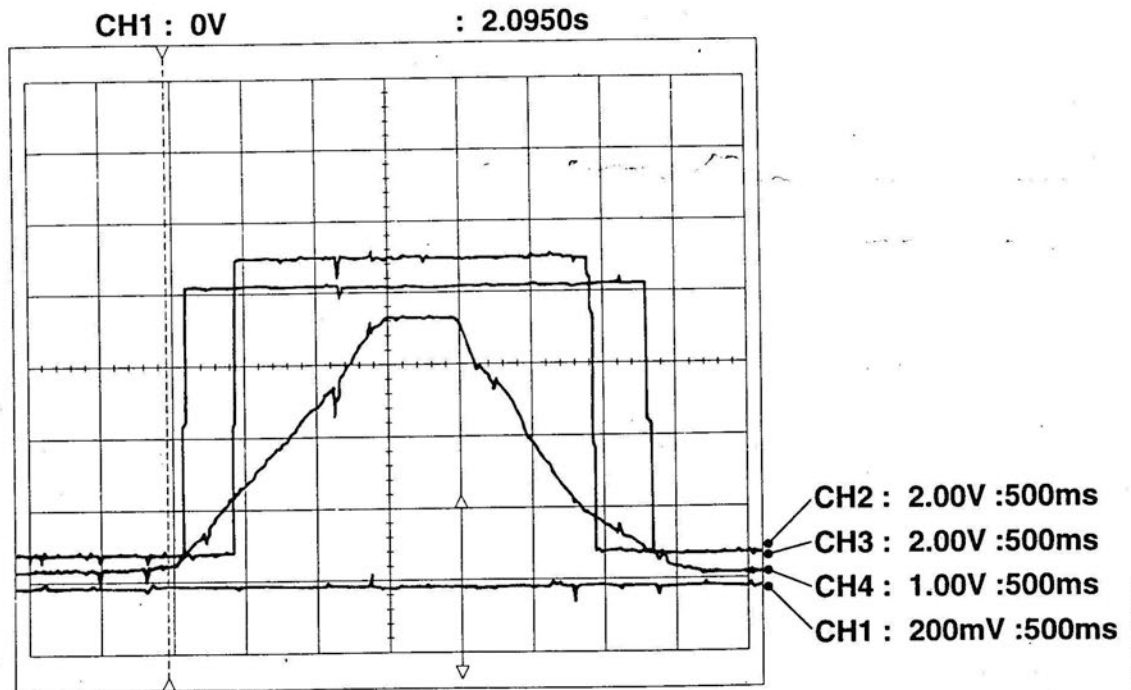

### Pin 15 — Brake light switch

Note: OFF ► ON ► OFF

Also compare with command code 206

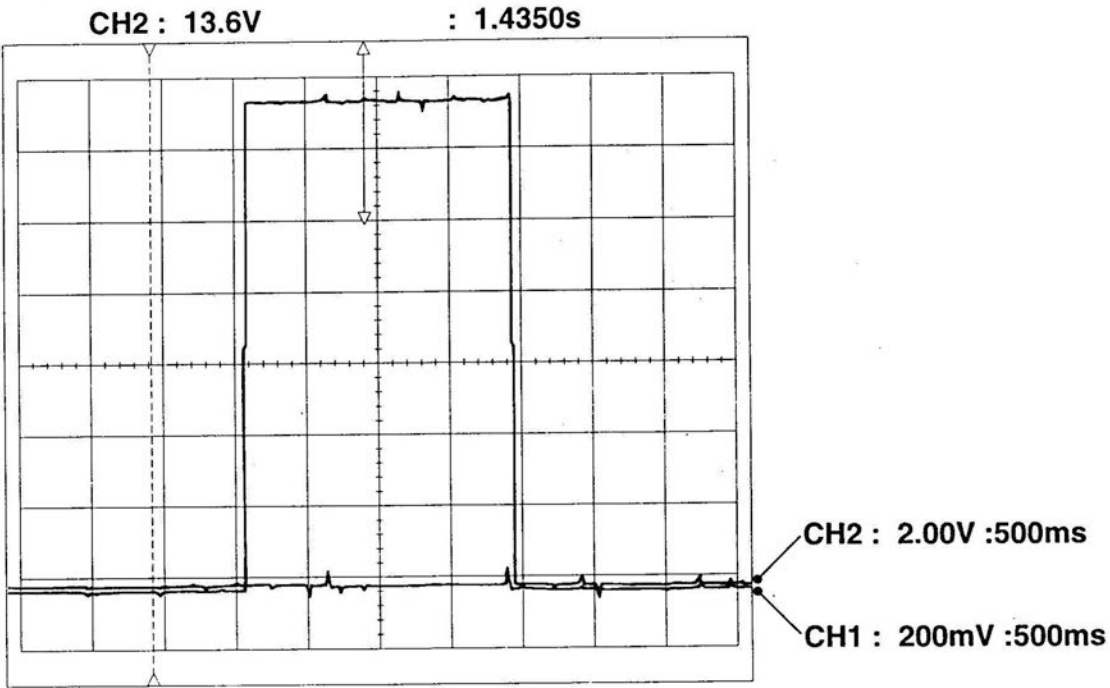

### Pin 16 — Throttle position sensor (moving)

Note: Time not relevant, wide open means pressed beyond pressure point in pedal sensor

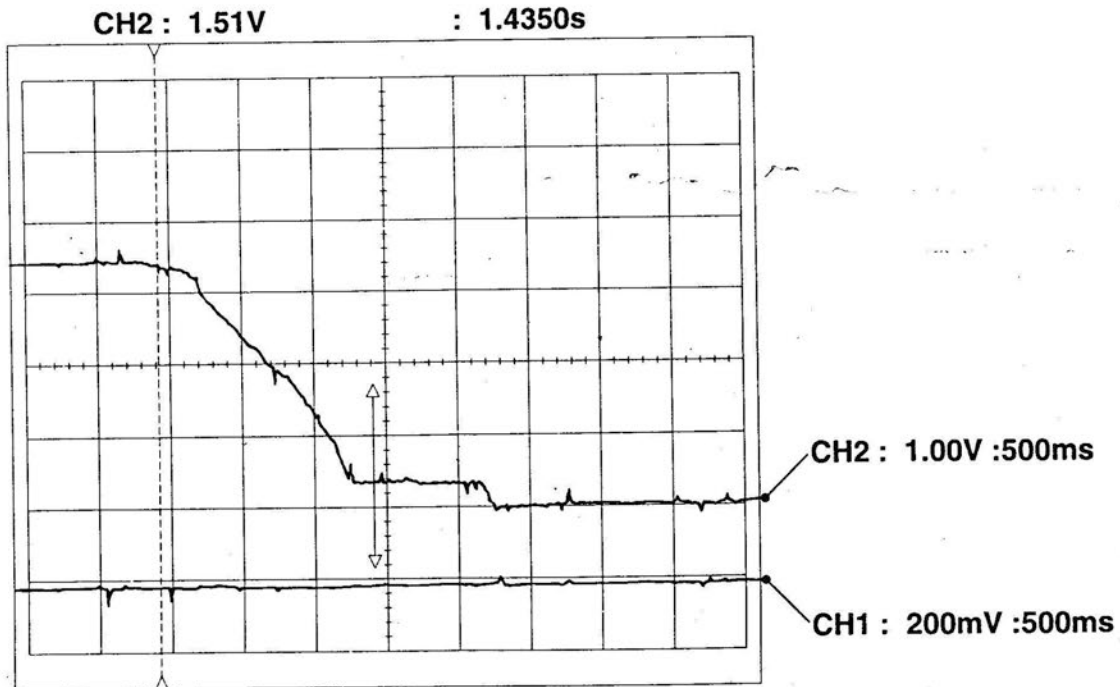

### Pin 16a — Throttle position sensor (closed)

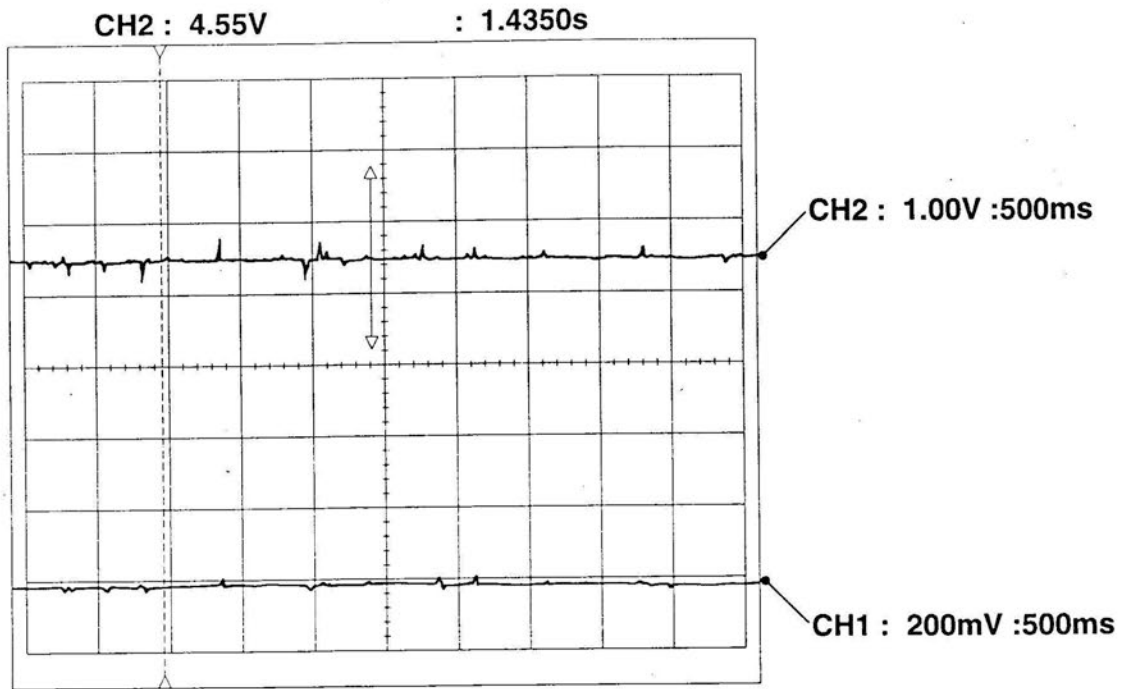

### Pin 16b — Throttle position sensor (opening > closing)

Note: CH2 = throttle position sensor  
CH3 = throttle body safety switch

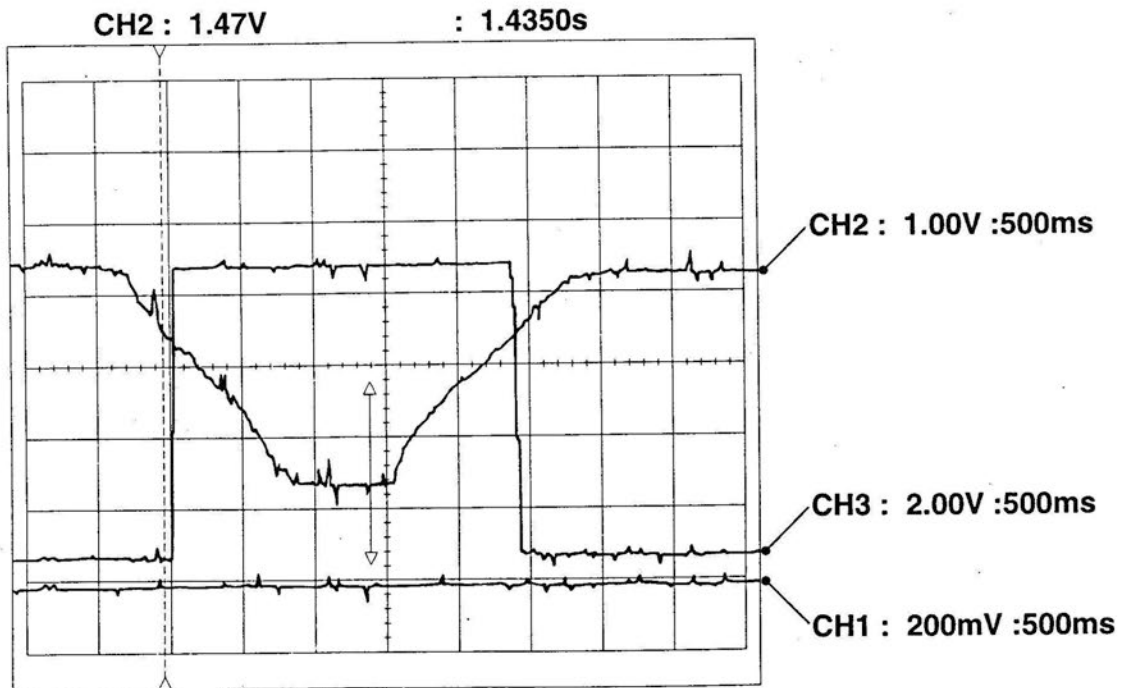

### Pin 17 — Accelerator pedal position sensor (moving)

Note: released ► depressed ► kick down ►  
fully depressed

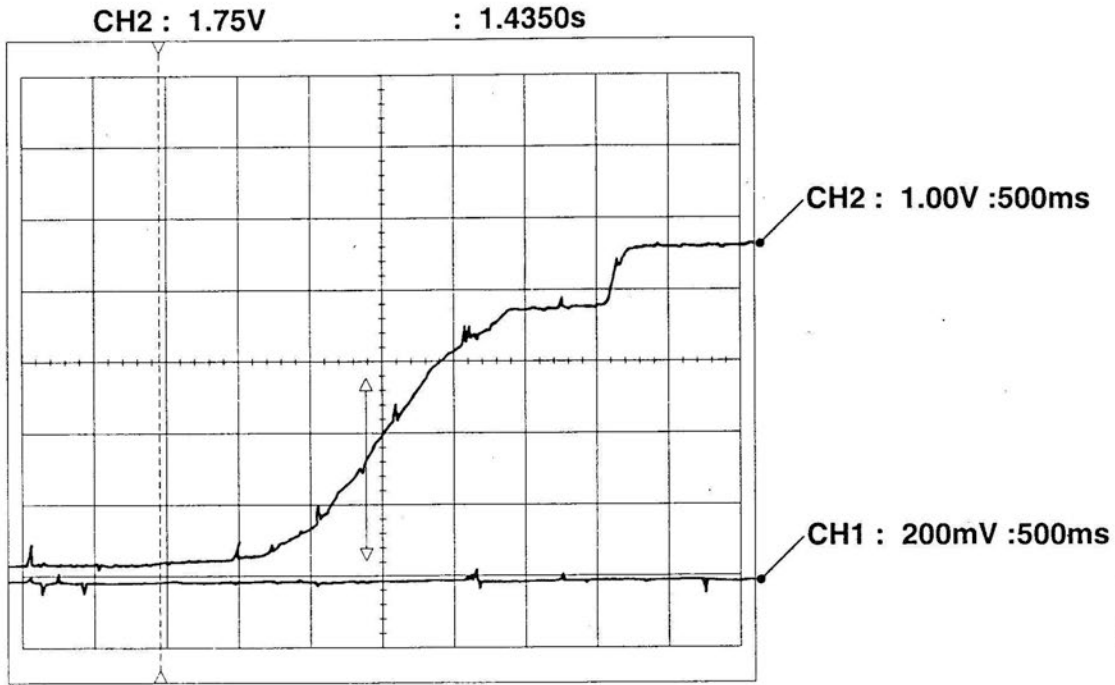

### Pin 17a — Accelerator pedal position sensor (released)

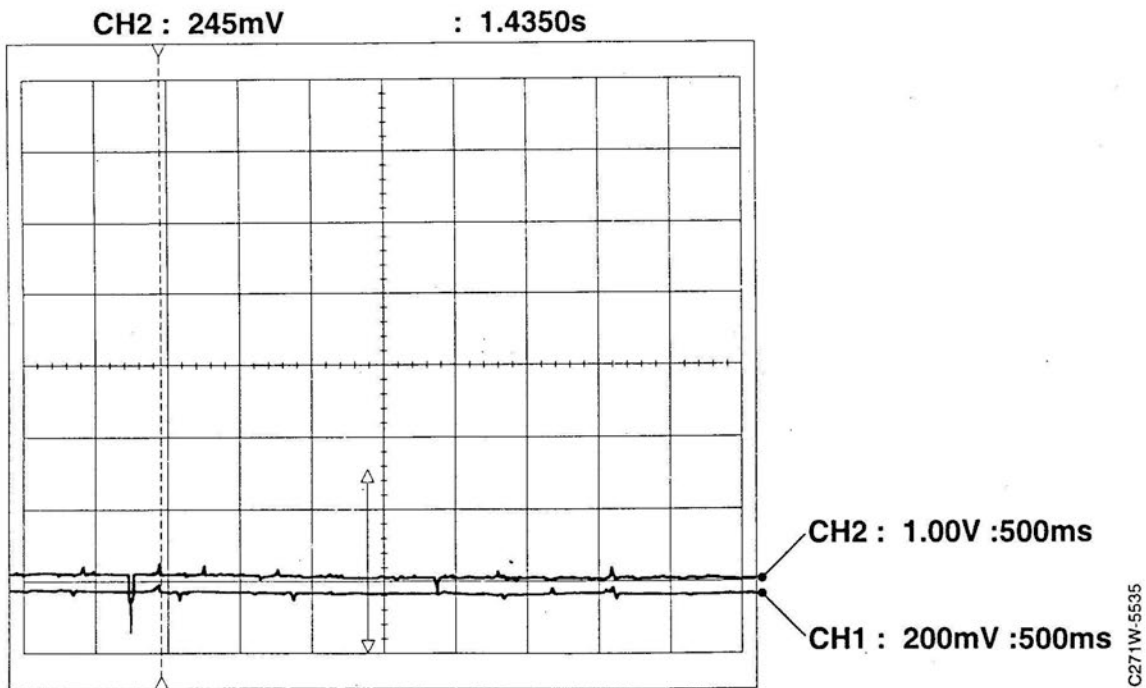

### Pin 17b — Accelerator pedal position sensor

Note: released ▶ depressed ▶ released  
CH2 = accelerator pedal position sensor  
CH3 = accelerator pedal safety switch

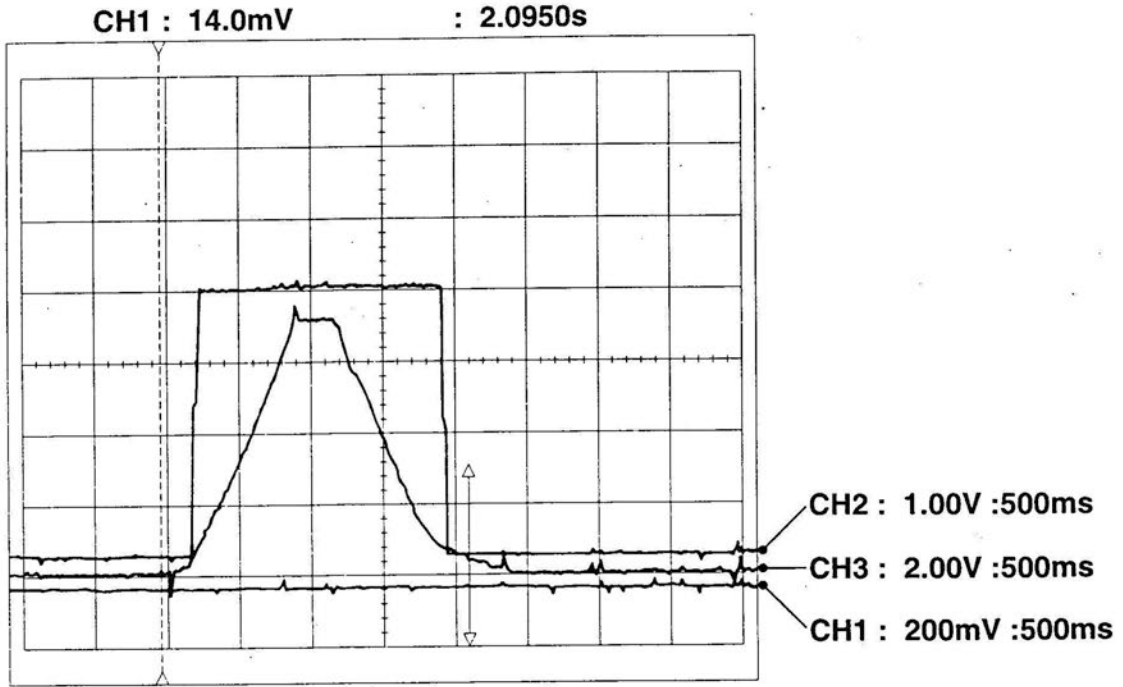

### Pin 16/17 — Throttle position sensor/Pedal position sensor

Note: CH2 = throttle position sensor  
CH3 = pedal position sensor

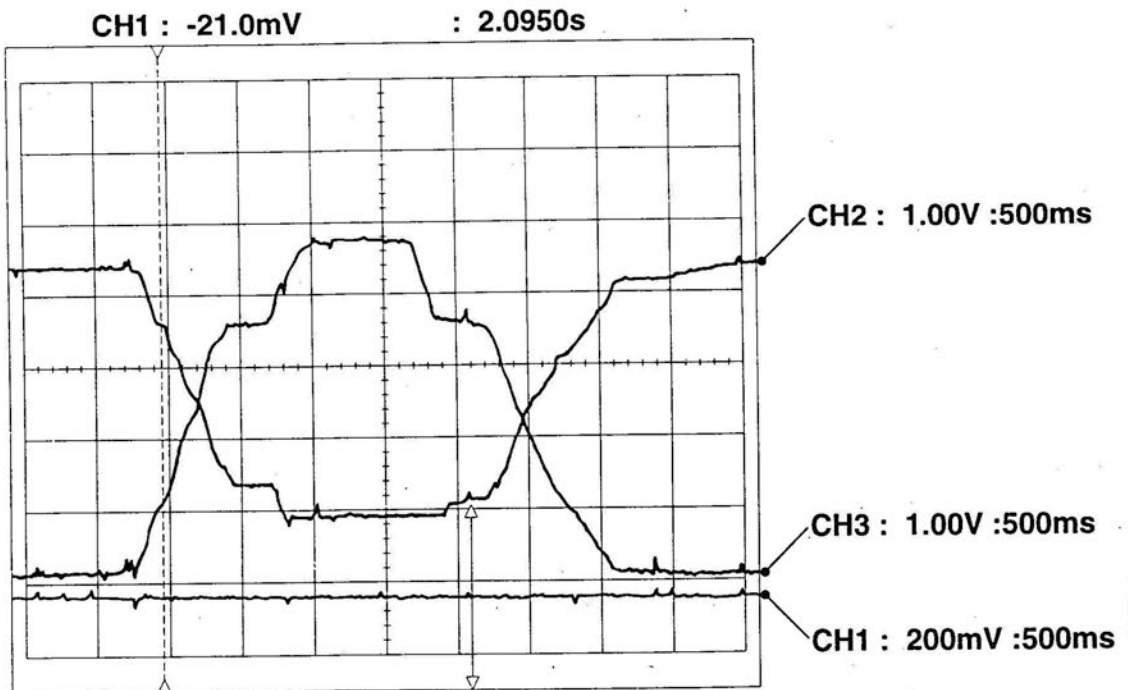

### Pin 18 — Cruise control "RESUME"

Note: released ▶ depressed ▶ released

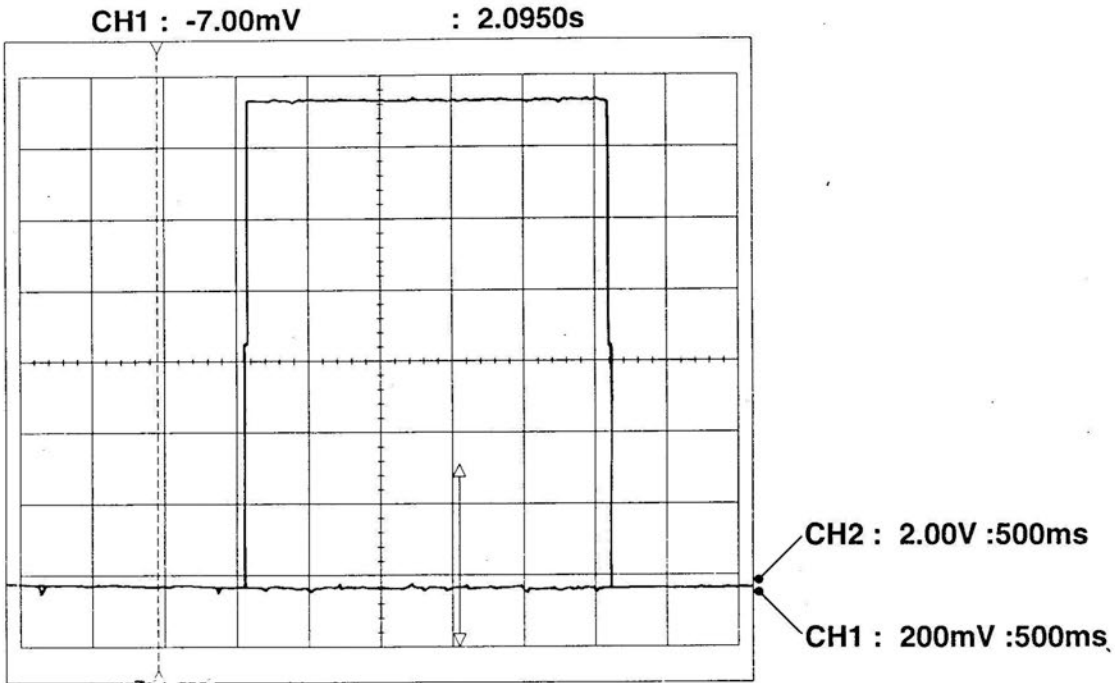

### Pin 19 — Cruise control "SET"

Note: released ▶ depressed ▶ released

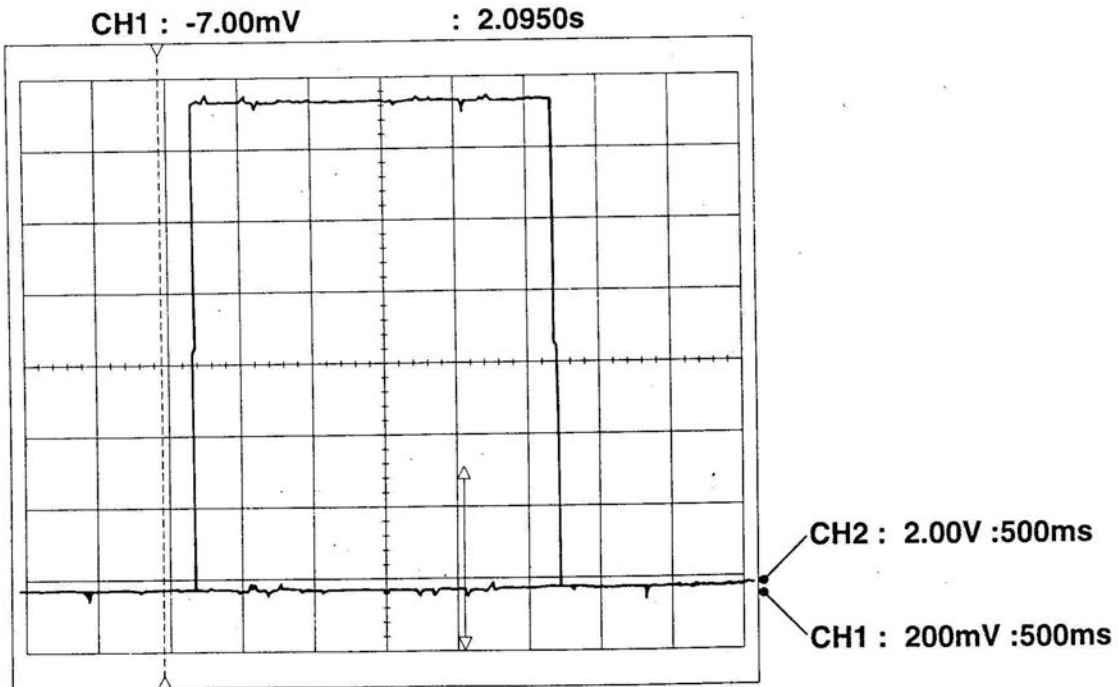



### Pin 20/21 — Throttle motor (pin 20) / (pin 21)

Note: Engine at idle

CH2 = throttle motor (pin 20)

CH3 = throttle motor (pin 21)

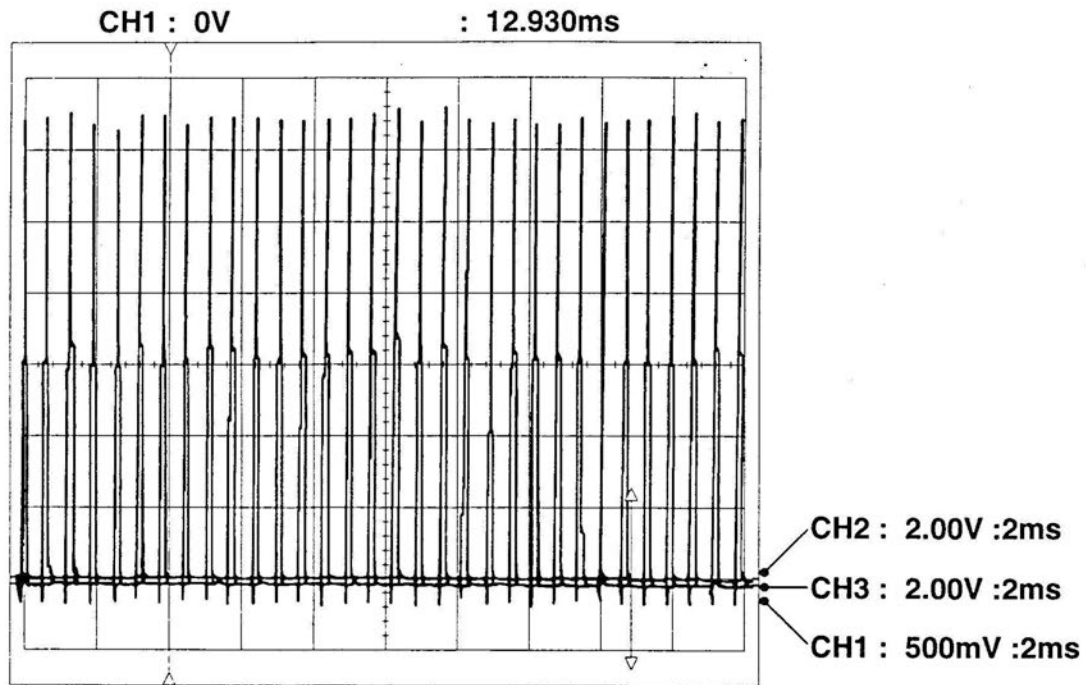

C271W-5540

### Pin 20/21a — Throttle motor (pin 20) / (pin 21)

Note: Only ignition ON:

Open throttle quickly by depressing accelerator pedal

CH2 = throttle motor (pin 20)

CH3 = throttle motor (pin 21)

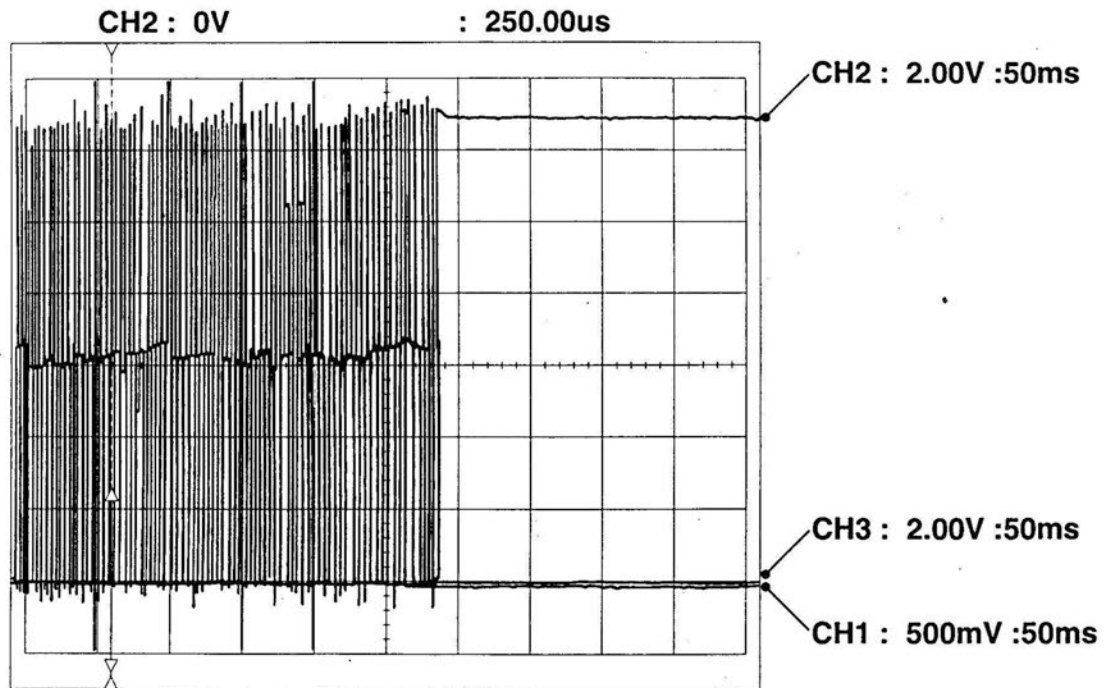

C271W-5541

### Pin 20/21b —Throttle motor (pin 20) / (pin 21)

Note: Only ignition ON:  
Close throttle quickly by snapping back  
depressed accelerator pedal

CH2 = throttle motor (pin 20)  
CH3 = throttle motor (pin 21)

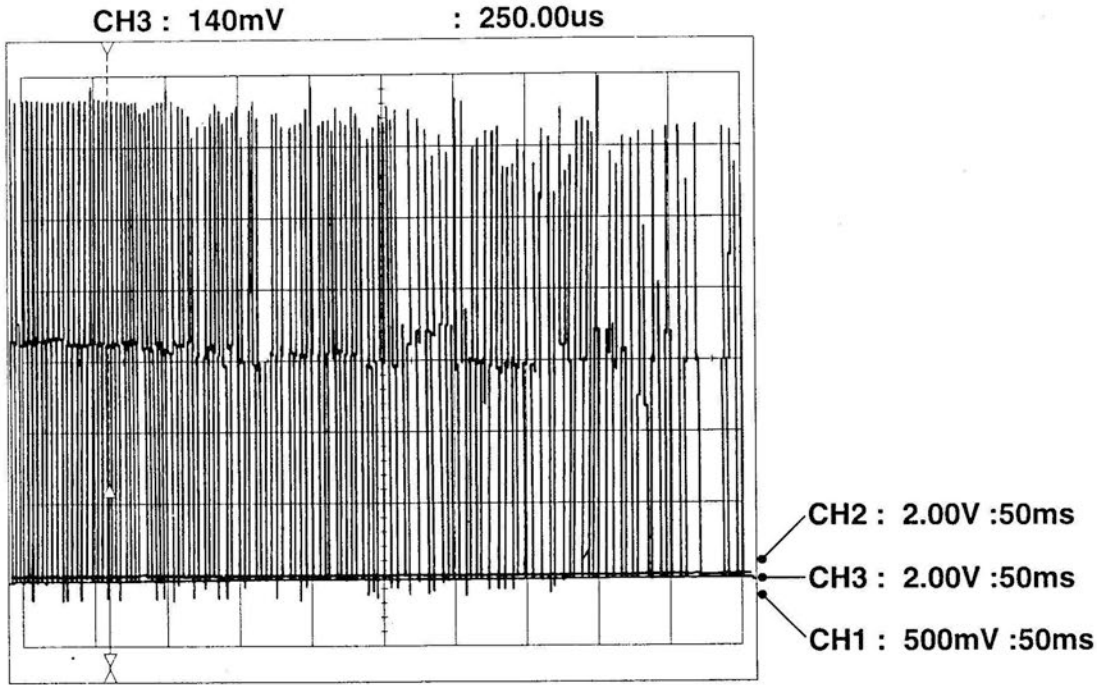

### Pin 20/21c —Throttle motor (pin 20) / (pin 21)

Note: Only ignition ON:  
Open throttle in normal manner  
CH2 = throttle motor (pin 20)  
CH3 = throttle motor (pin 21)

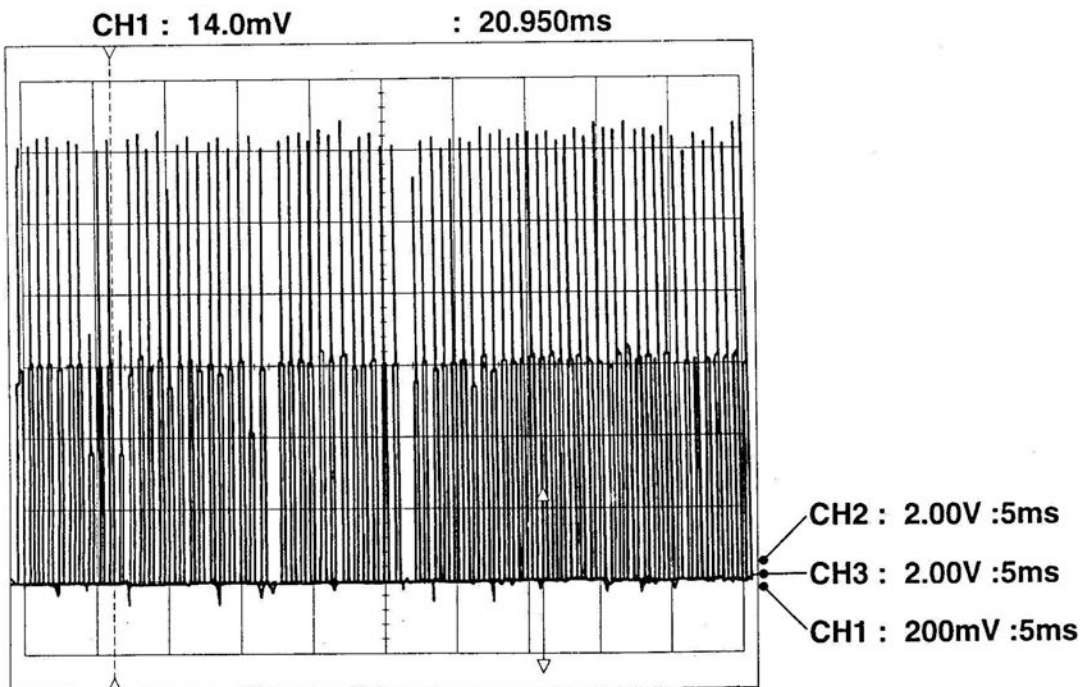

### Pin 20/21d — Throttle motor (pin 20) / (pin 21)

Note: Only ignition ON:  
Close throttle in normal manner

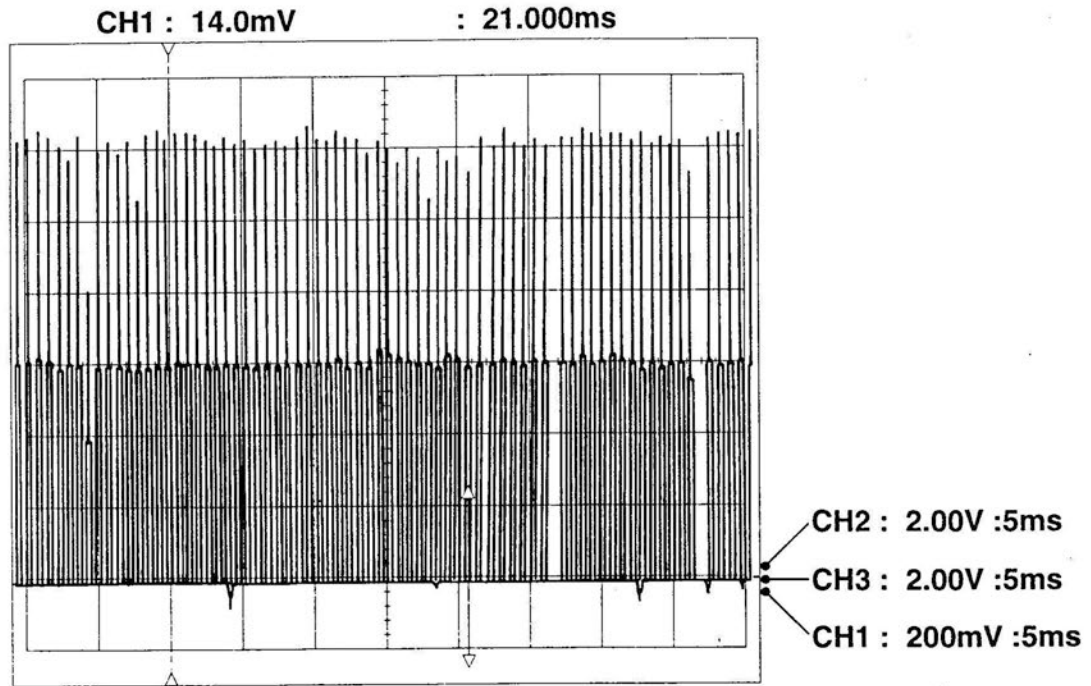

### Pin 22 — +30 supply voltage from main relay

Note: Ignition OFF ► ON ► OFF  
Also refer to pin 25

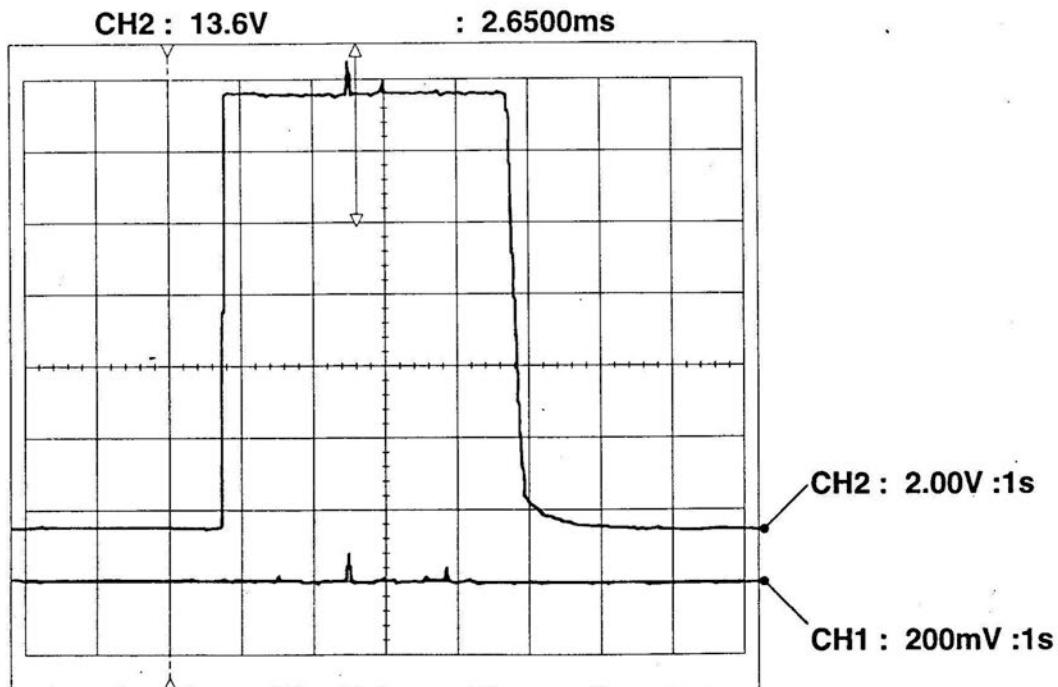

**Pin 22/25 — +30/ +15 supply voltage**

Note: Switch ignition ON:  
 CH2 = +30 supply voltage  
 CH3 = +15 supply voltage

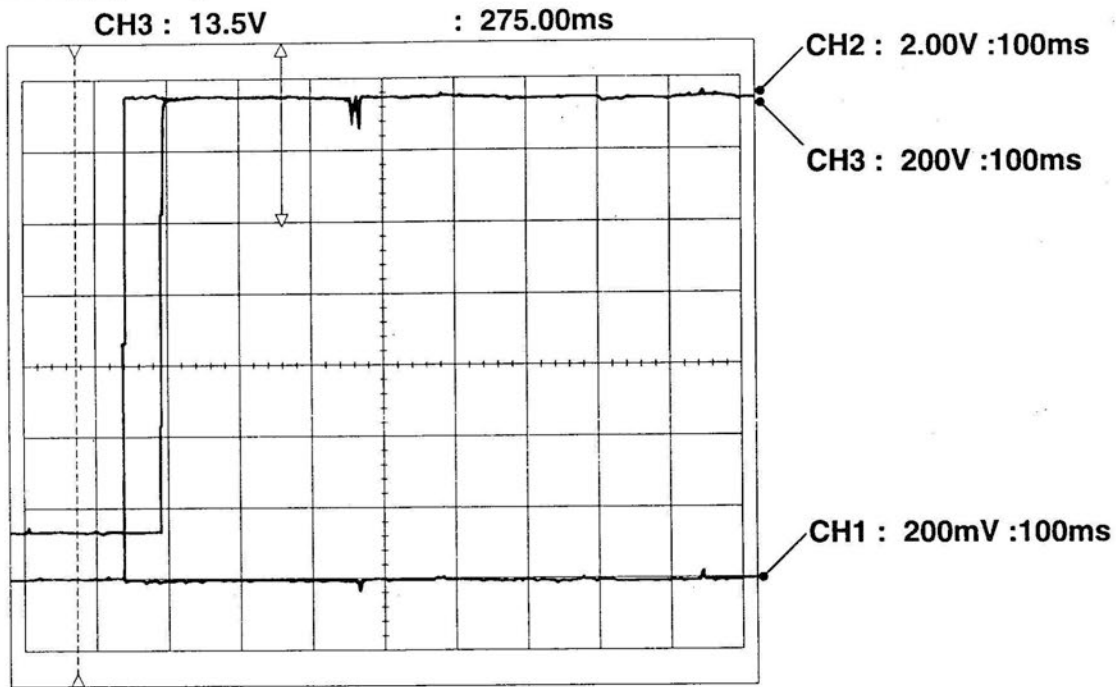

C271W-5546

**Pin 22/25a — +30/+15 supply voltage**

Note: Switch ignition OFF (power-off test)  
 CH2 = +30 supply voltage  
 CH3 = +15 supply voltage

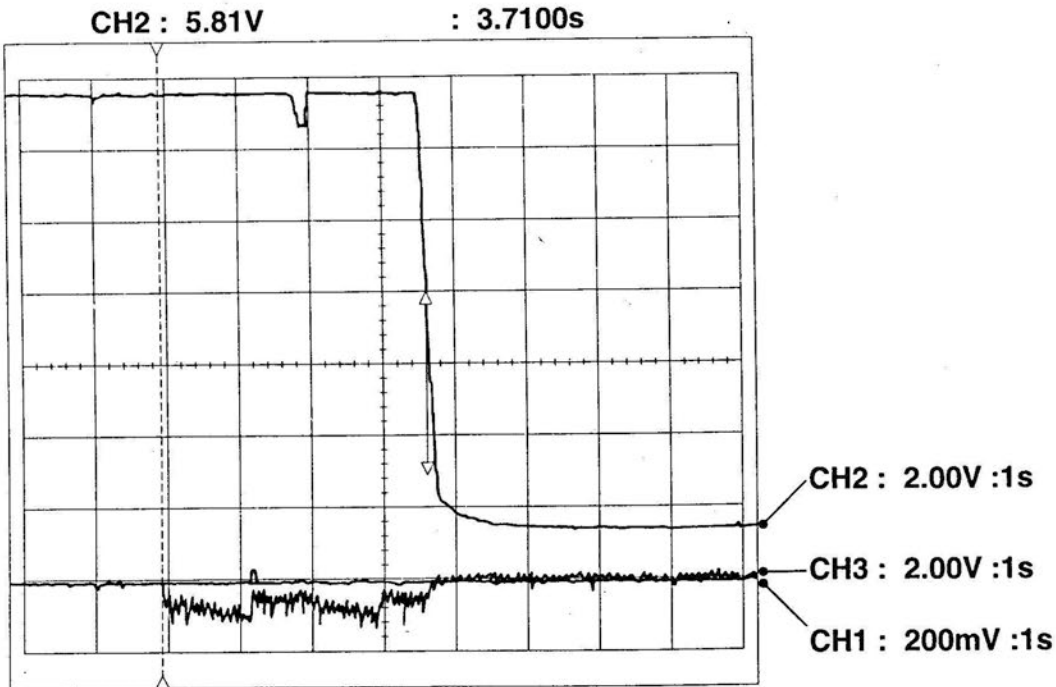

C271W-5547

### Pin 22/25b — +30/+15 supply voltage

Note: Switch ignition OFF: (short power-off test)

CH2 = +30 supply voltage

CH3 = +15 supply voltage

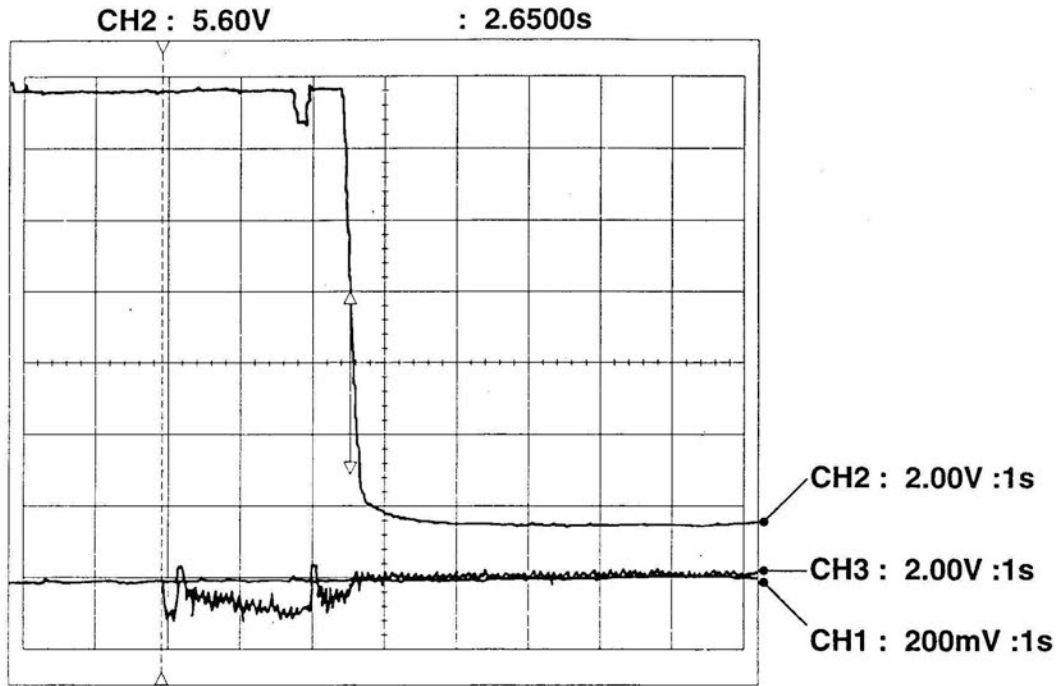

C271W-5548

### Pin 23 — TCS CTRL lamp

Note: Switch ignition ON and OFF

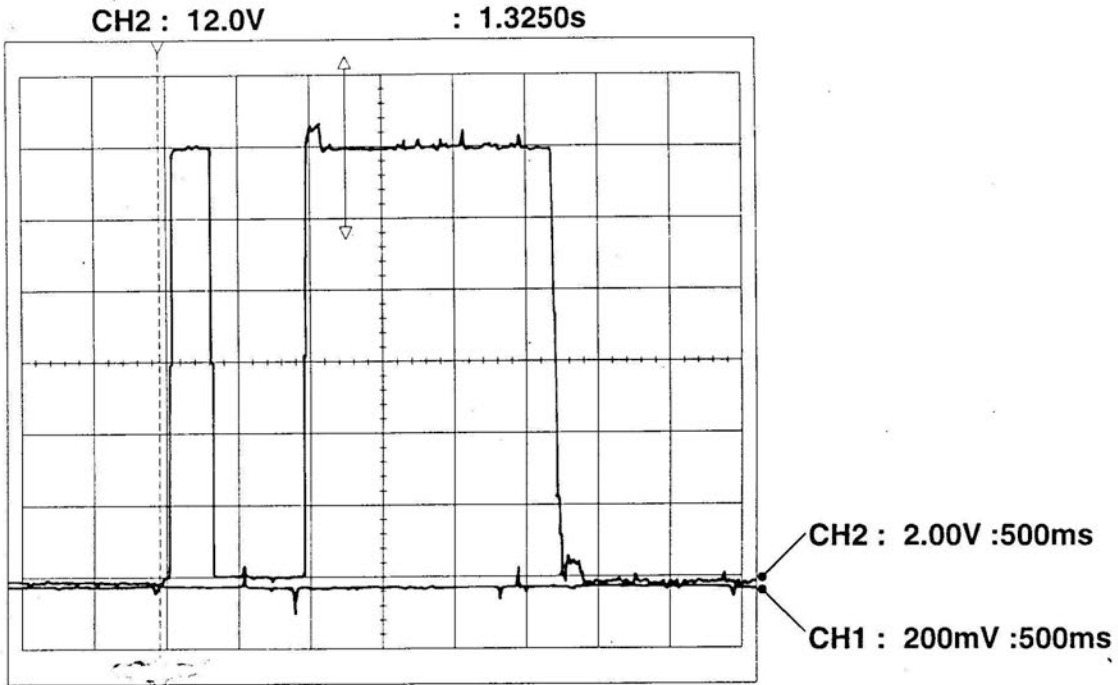

### Pin 23a — TCS CTRL lamp

Note: Enter scan tool code 553 for pulsing

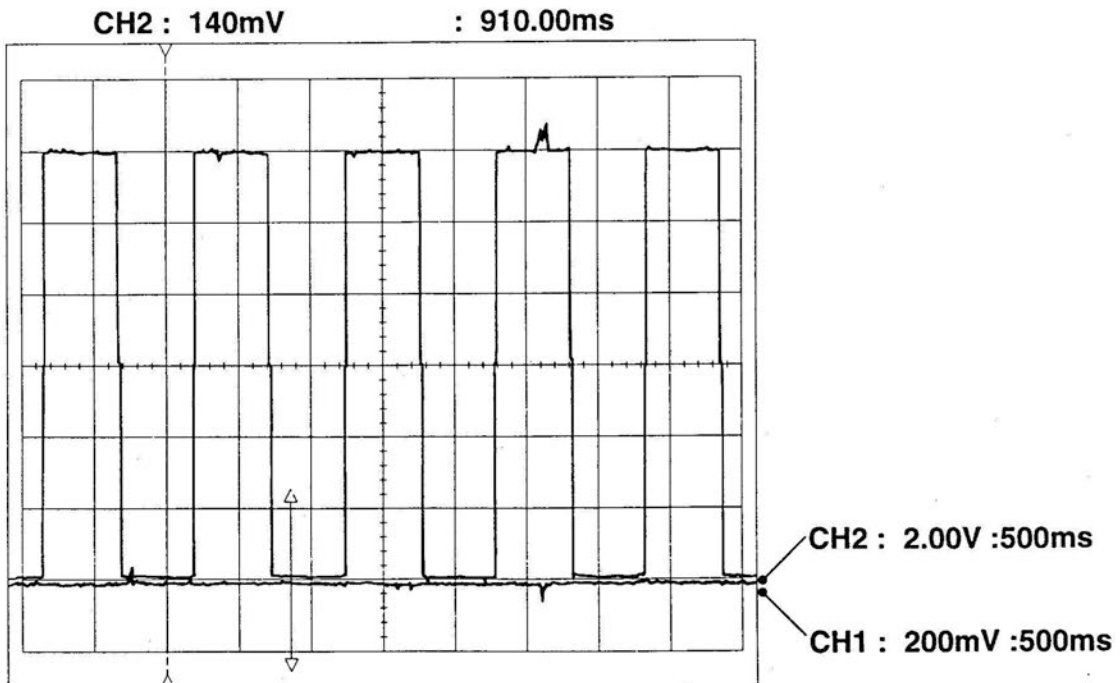

### Pin 25 — +15 supply voltage

Note: Ignition OFF ► ON ► OFF  
Also refer to pin 22

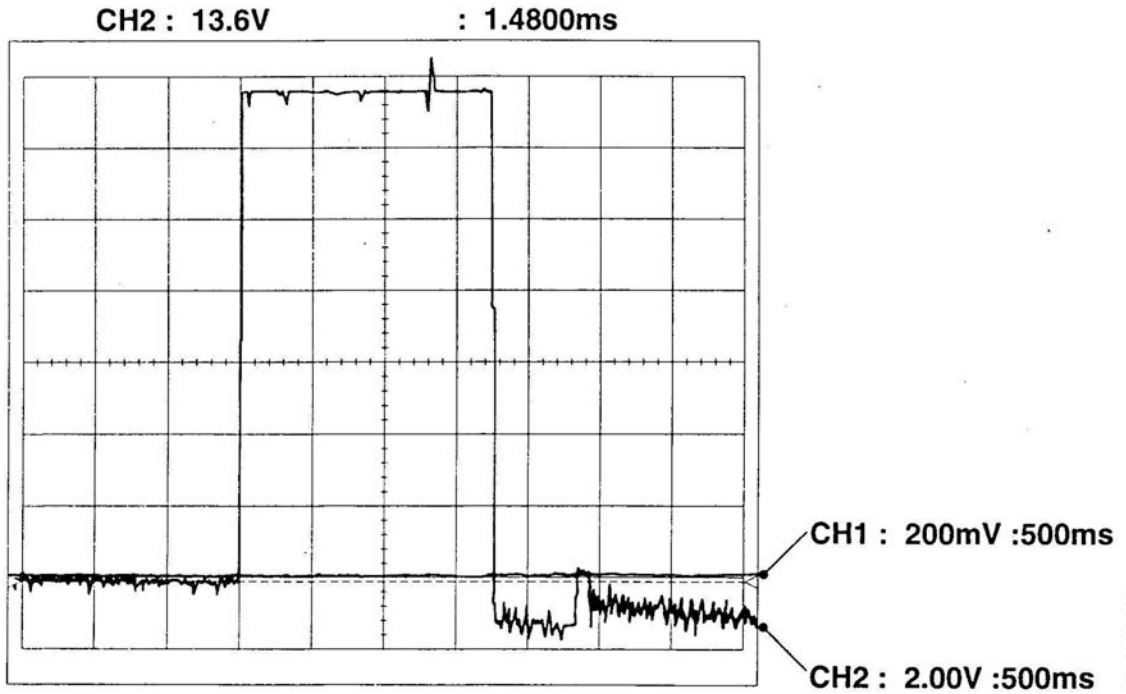

### Pin 26 — Throttle butterfly angle, PWM output

Note: Engine at idle, DI cars only  
(100 Hz, 5%)

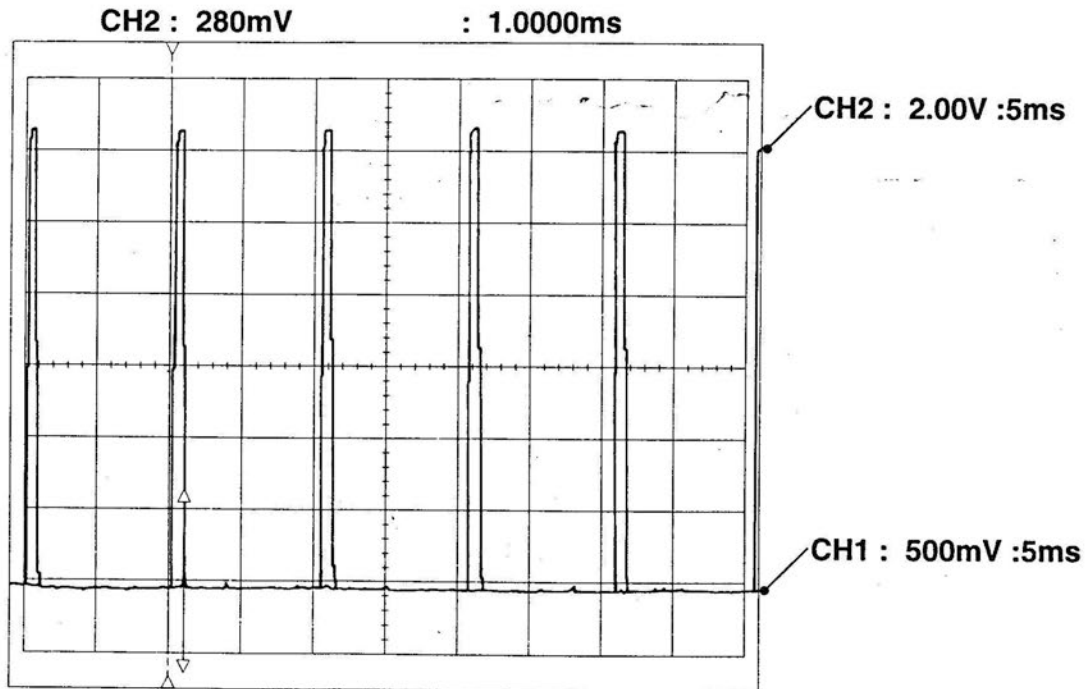

### Pin 26a — Throttle butterfly angle, PWM output

Note: Engine at full throttle, DI cars only  
(100 Hz, 95%)

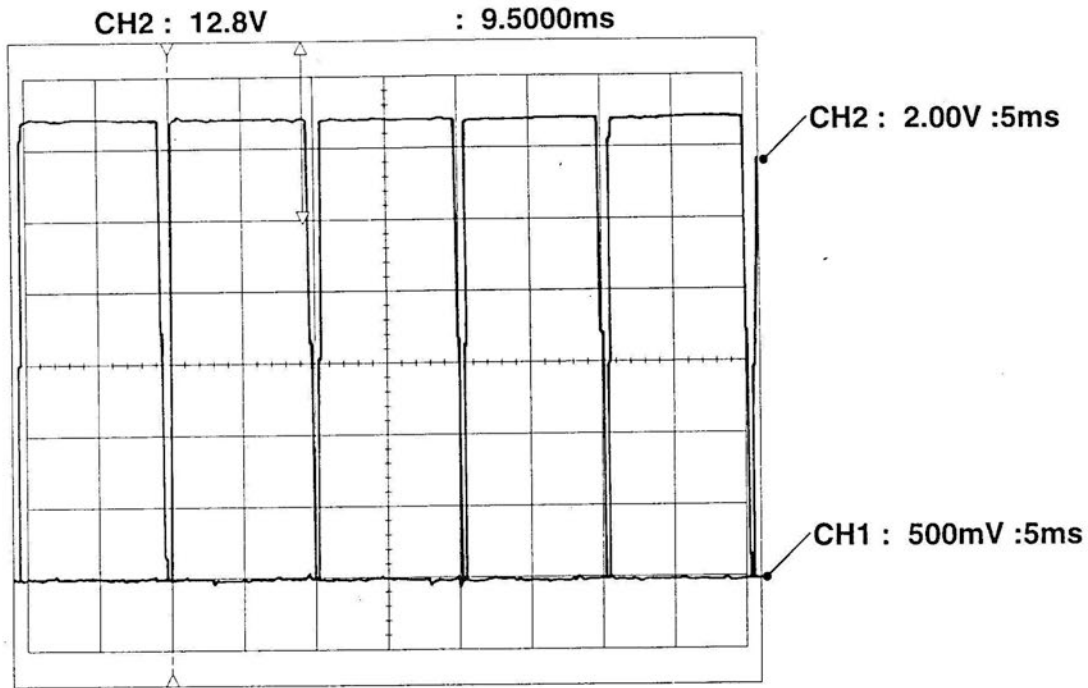

C271W-5553

### Pin 26b — Throttle butterfly angle, PWM output

Note: Engine at idle, TRIONIC cars only  
(200 Hz, 5%)

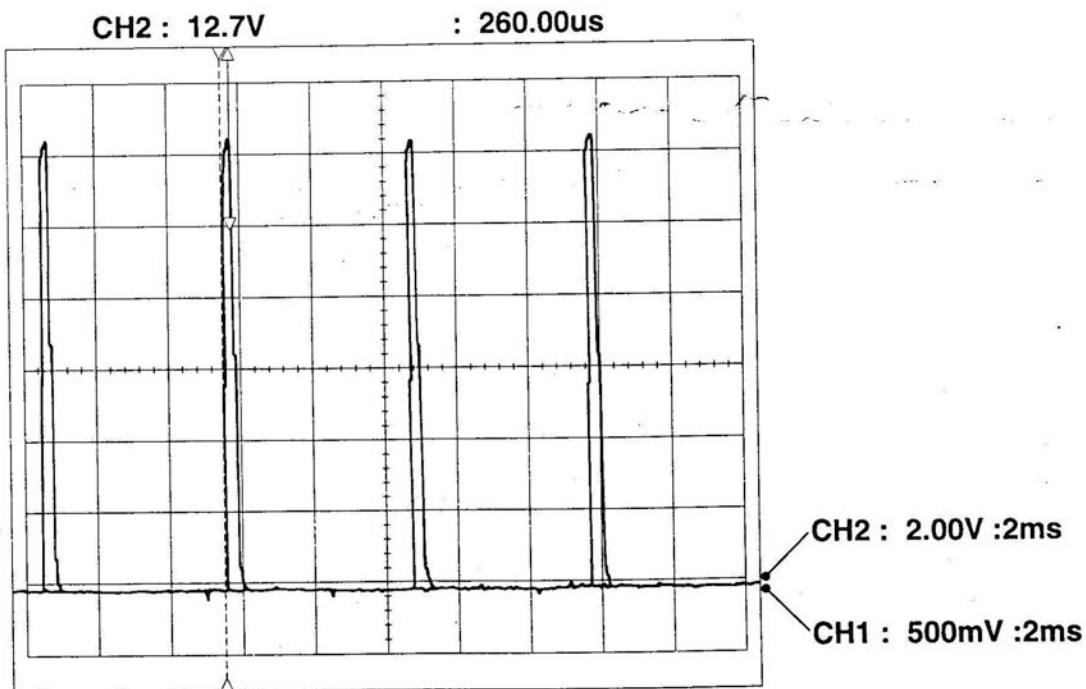

C271W-5554



### Pin 26c — Throttle butterfly angle, PWM output

Note: Engine at wide open throttle, TRIONIC cars only  
(200 Hz, 95%)

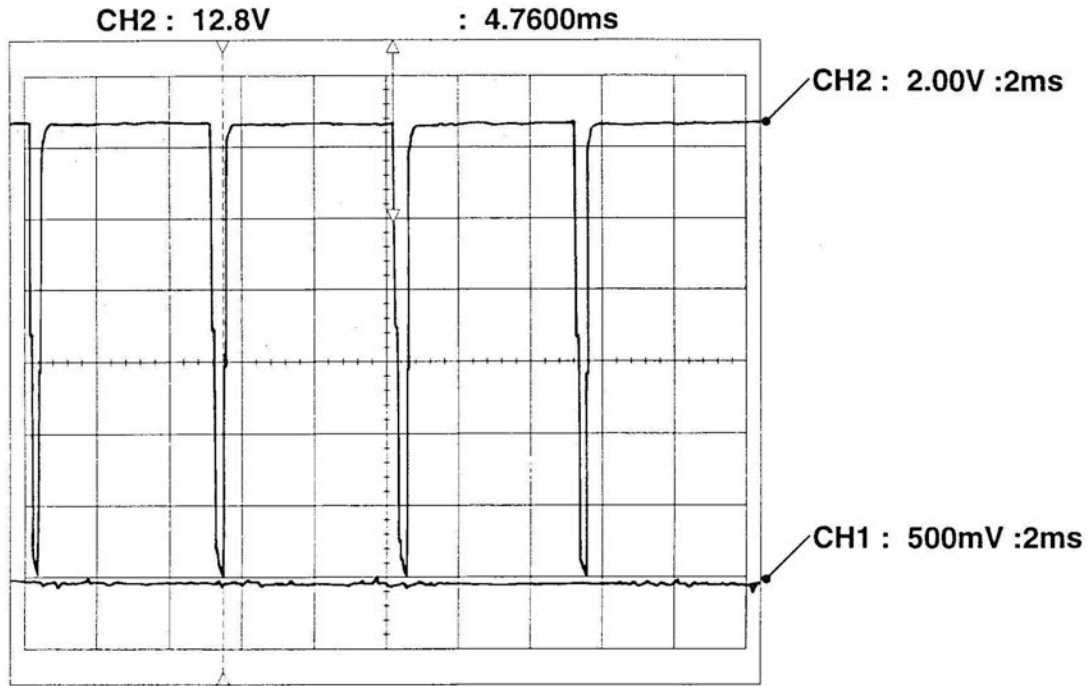

C271W-5555

### Pin 27 — Load signal (Tq)

Note: Engine at idle, without load.

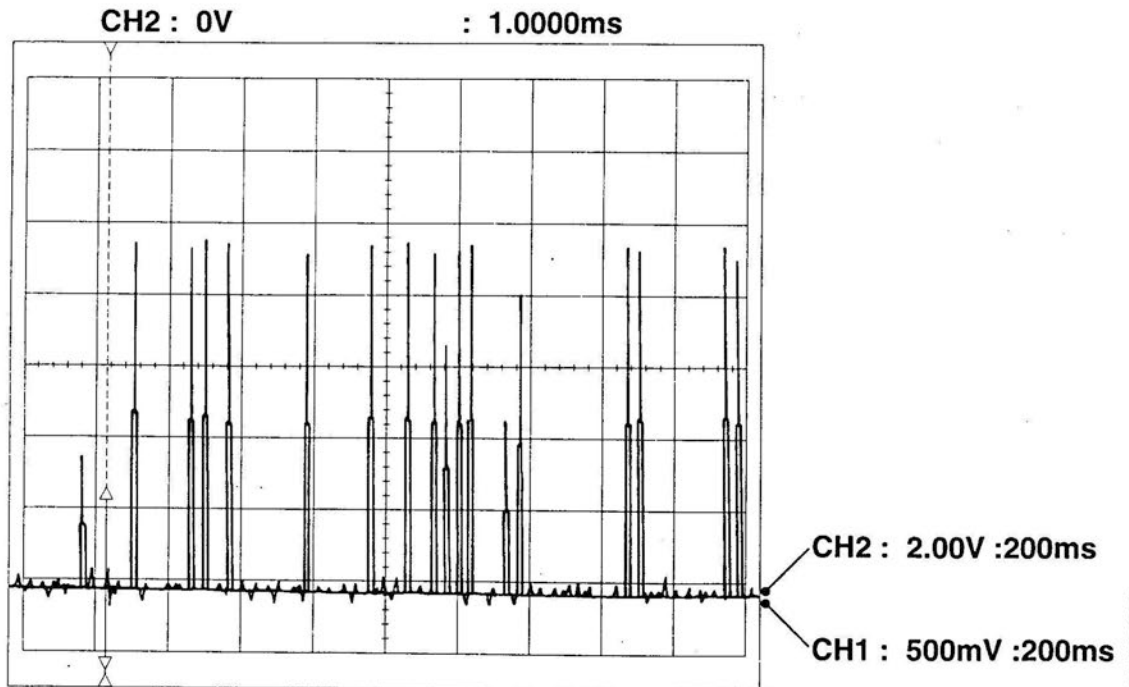

C271W-5556

### Pin 27a — Load signal (Tq)

Note: Engine at idle, single pulse without load

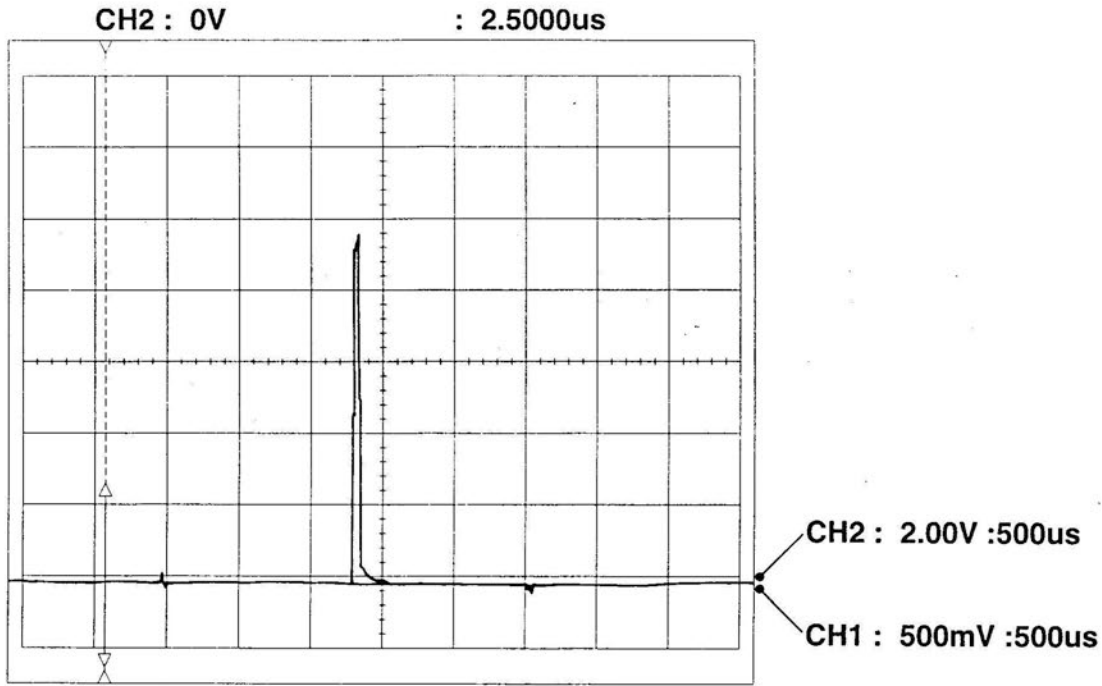

C271W-5557

### Pin 27b — Load signal (Tq)

Note: Engine at idle, single pulse with load.

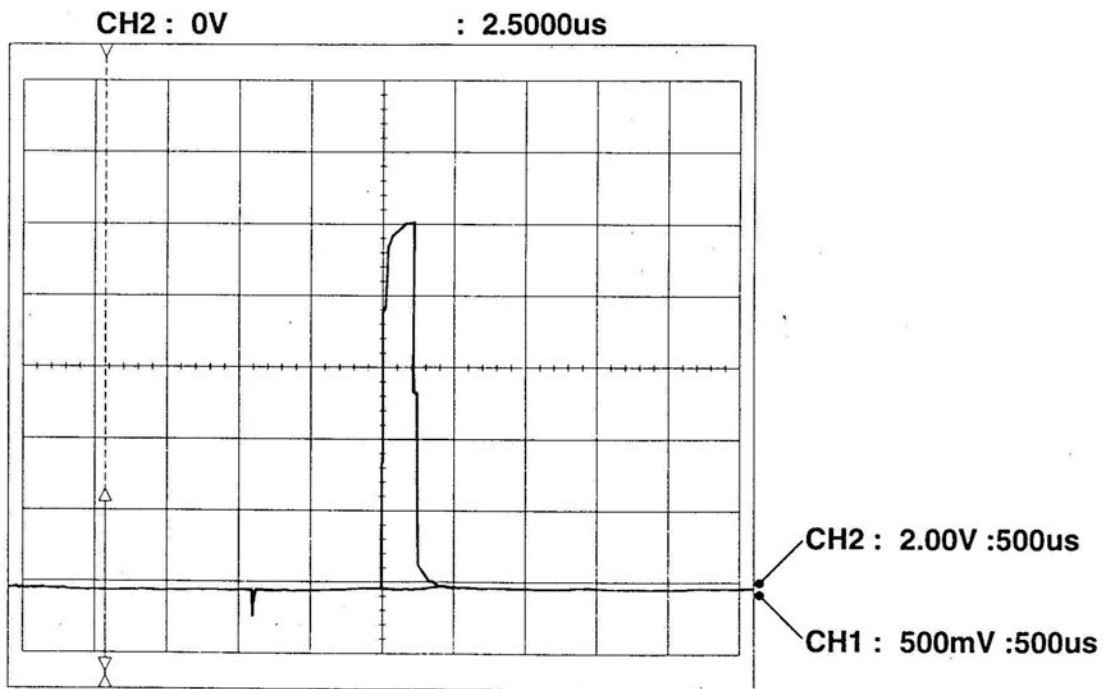

C271W-5558

### Pin 28 — Throttle body safety switch

Note: Butterfly closed ► butterfly open

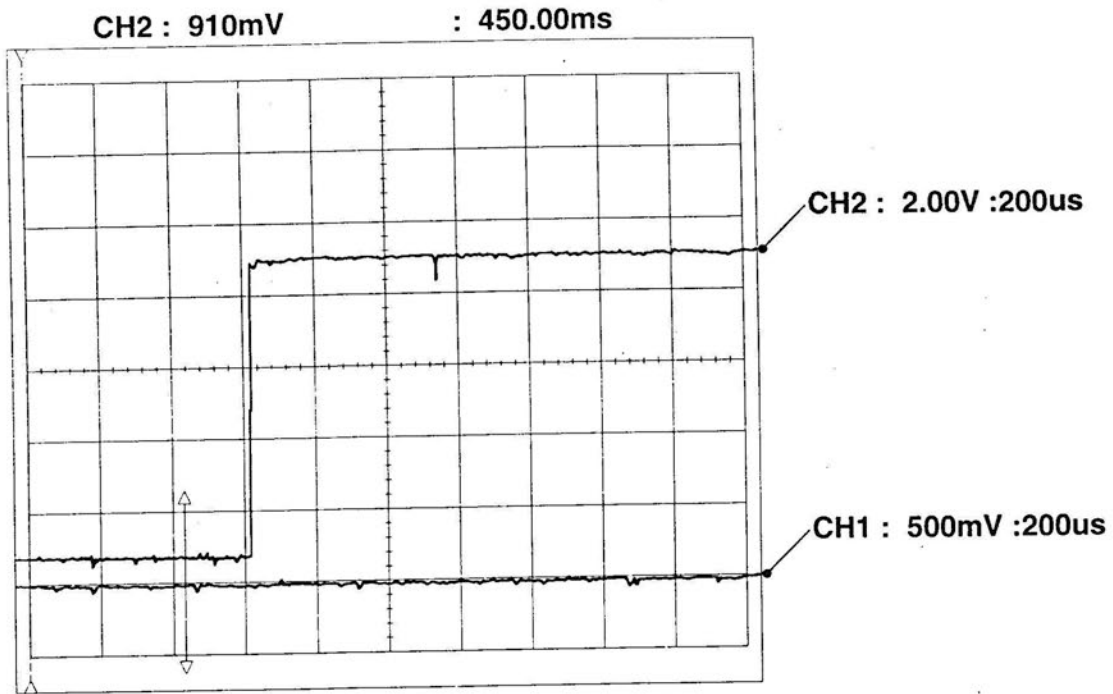

C271W-5559

### Pin 29 — TC/ABS interface, input signal

Note: Manual gearbox cars

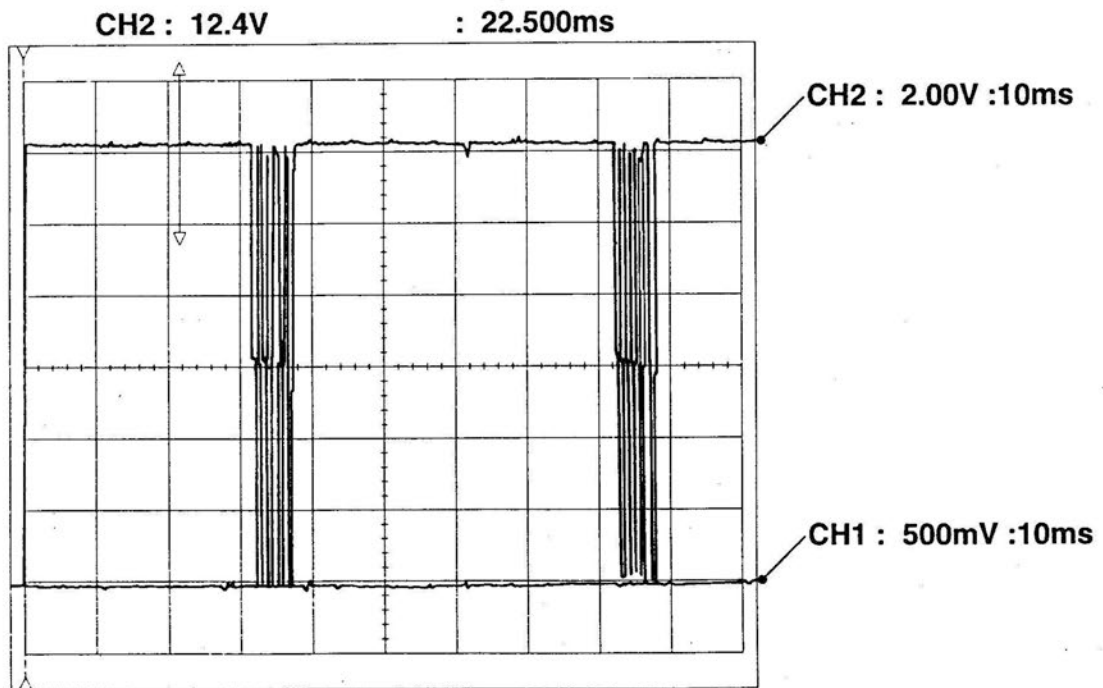

C271W-5560

### Pin 31 — Cruise Control "ON/OFF"

Note: OFF ► ON

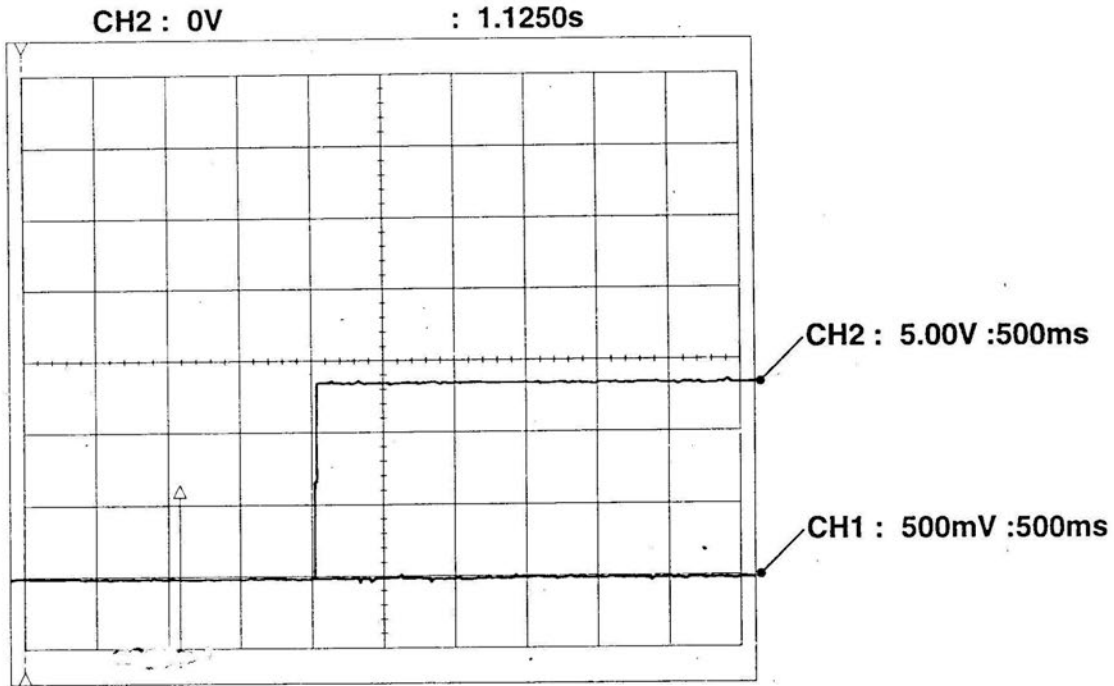

### Pin 32 — TC/ABS interface, output signal

Note: Manual gearbox cars

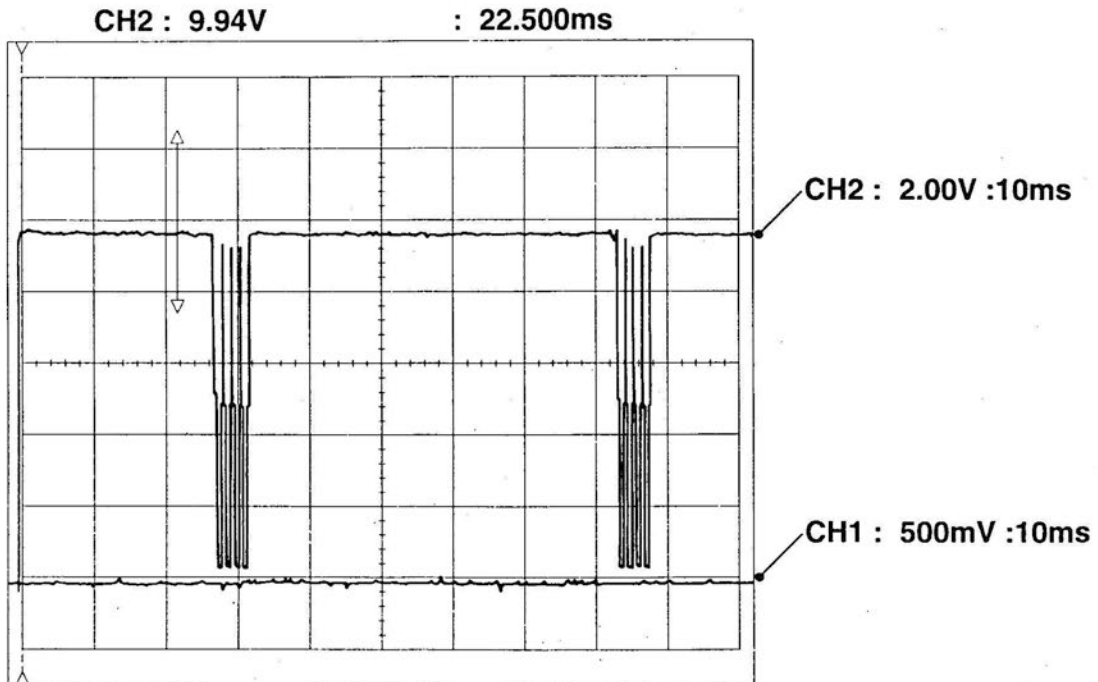

## Pin 33 — Engine coolant temperature sensor

Note: Engine coolant temperature  $\approx 40^{\circ}\text{C}$   
( $104^{\circ}\text{F}$ )

Lower temp.  $\blacktriangleright$  higher reading

Higher temp.  $\blacktriangleright$  lower reading

Also compare with scan tool code 250.

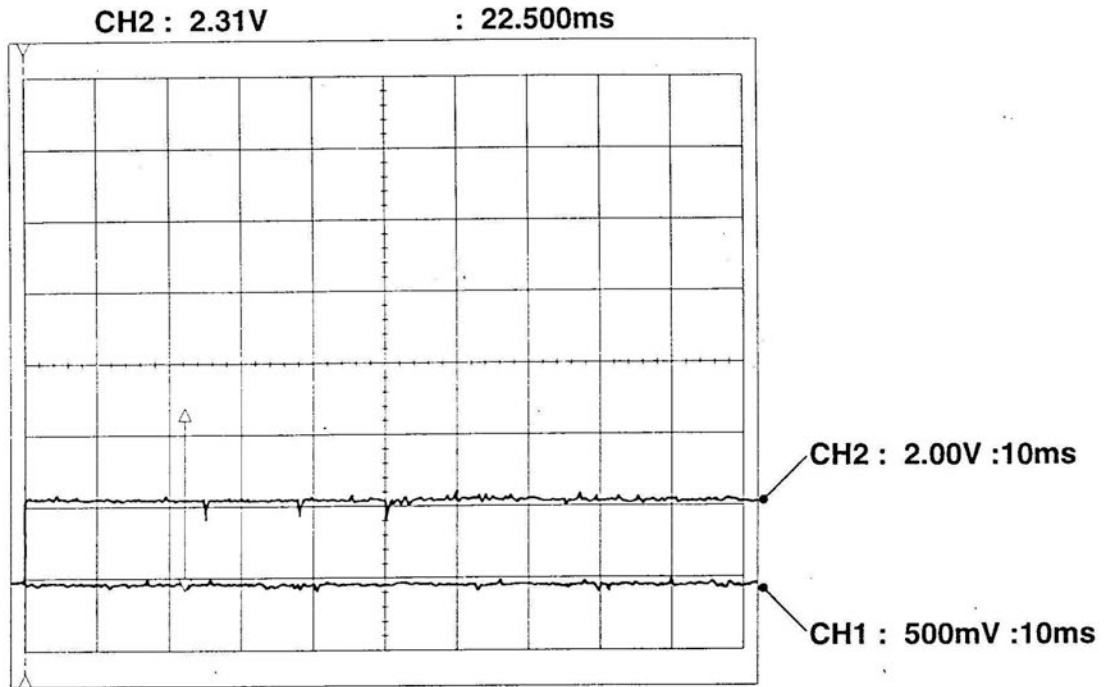

### Pin 34 — Diagnostic K-line

Note: No diagnostics, also see pin 9 for L-line

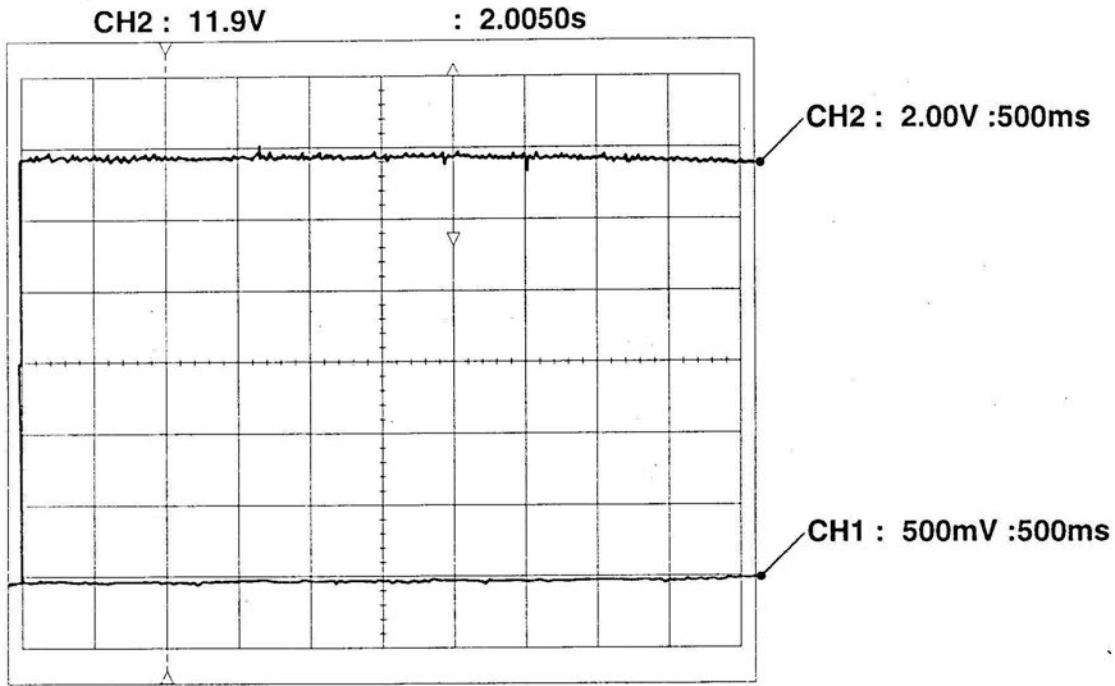

### Pin 34a — Diagnostic K-line

Note: When init. system No. 3

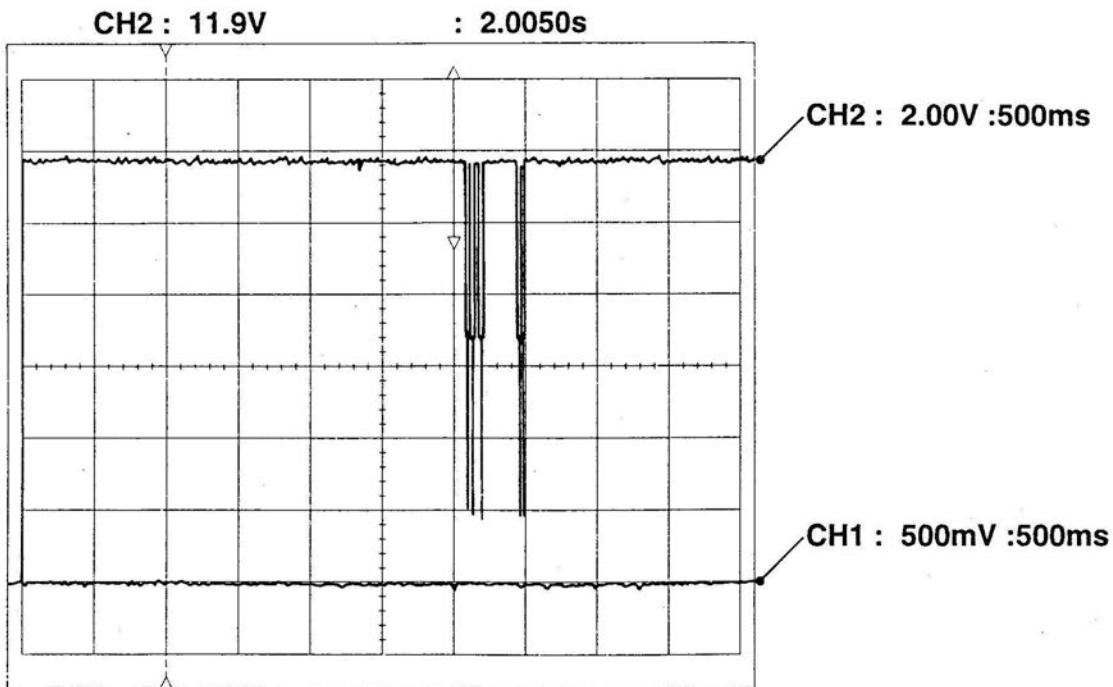

### Pin 35 — Safety Valve

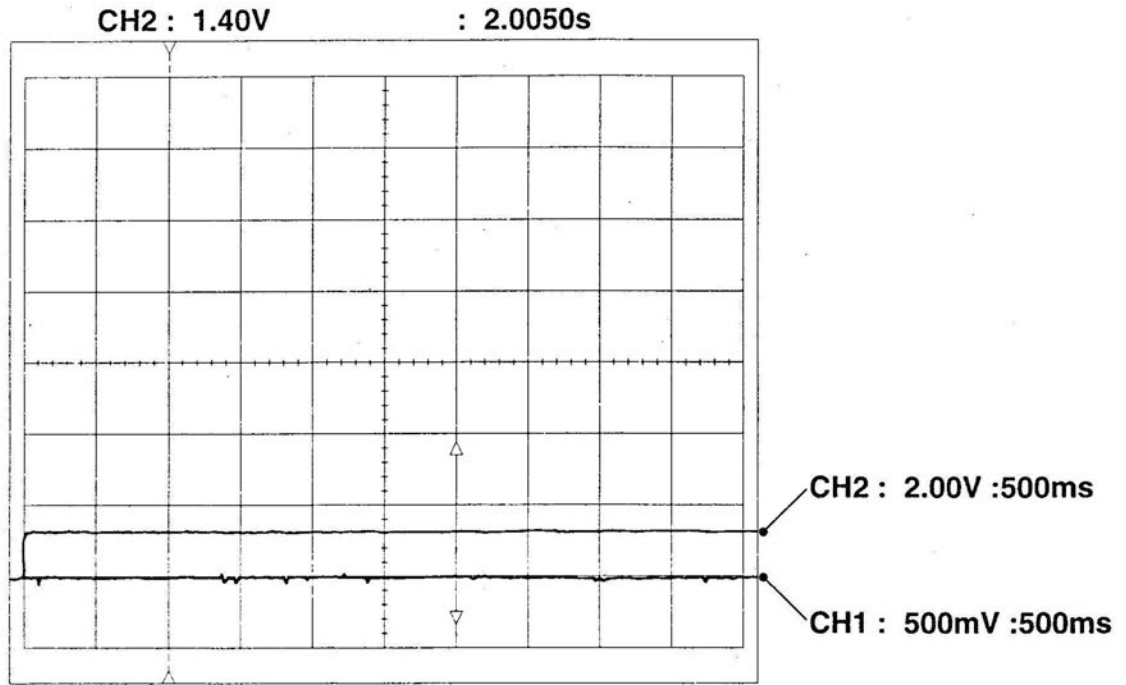

### Pin 35a — Safety Valve

Note: Use command code 551 for pulsing with 1 Hz

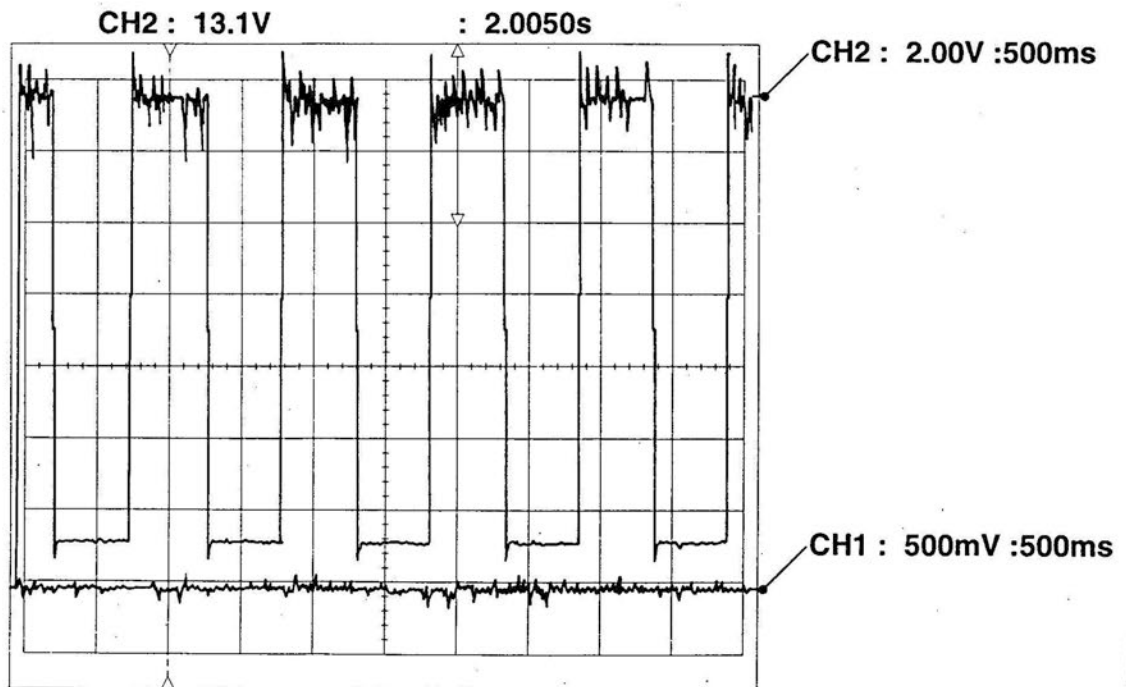

### Pin 36 — Brake/Clutch pedal safety switch

Note: released ► depressed ► released

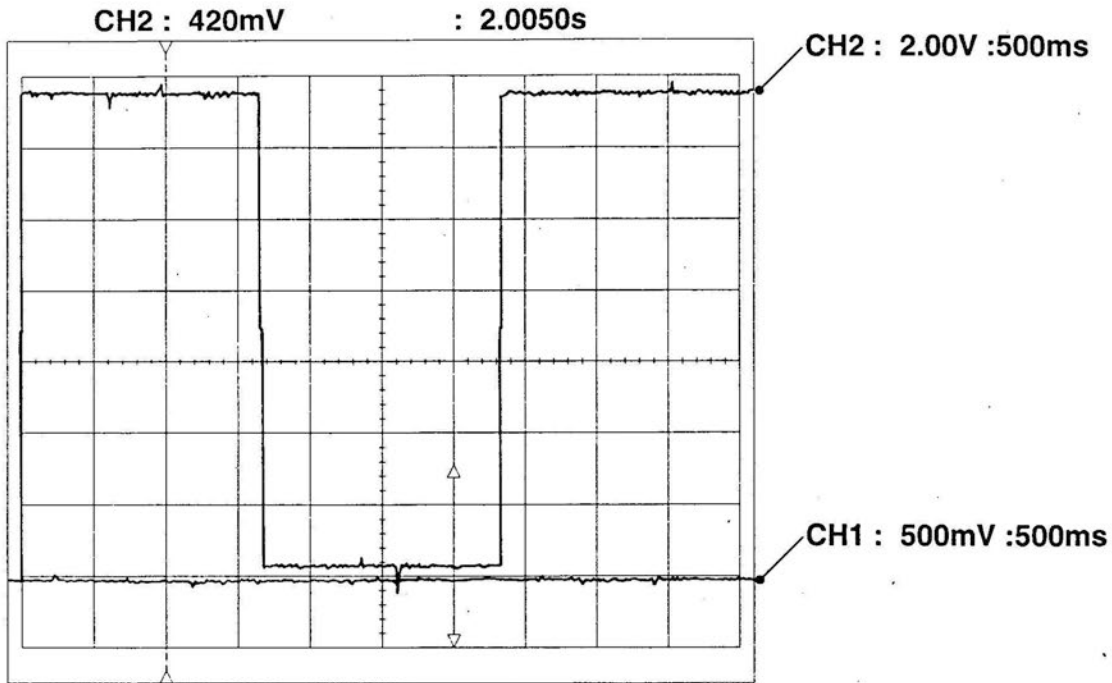

C271W-5568

### Pin 37 — ACC request

Note: OFF ► ON

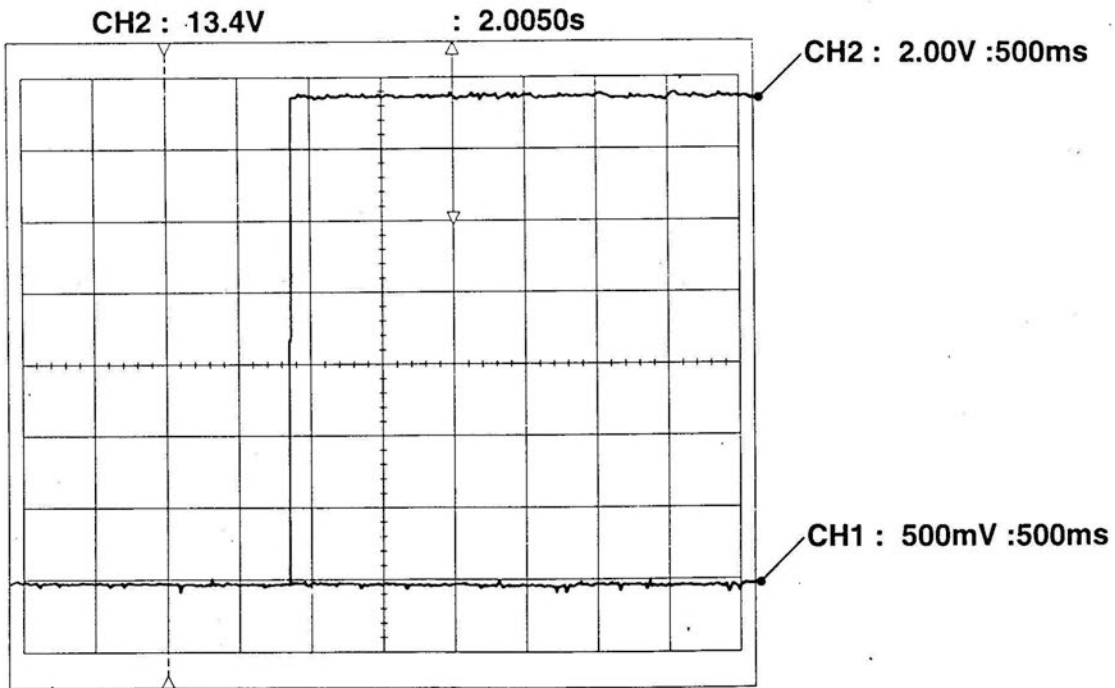

C271W-5569



### Pin 37/38 — ACC request/ACC relay

Note: OFF ► ON  
 CH2 = ACC request  
 CH3 = ACC relay

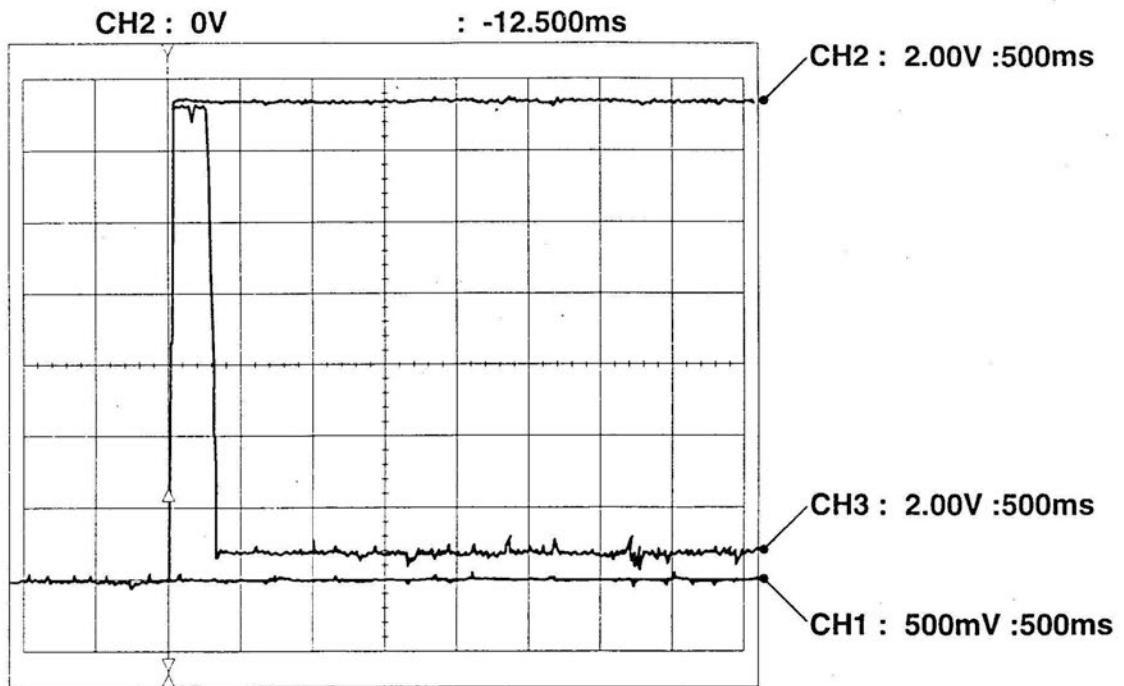

C271W-5570

### Pin 37/38a — ACC request/ACC relay

Note: ON ► OFF  
 CH2 = ACC request  
 CH3 = ACC relay

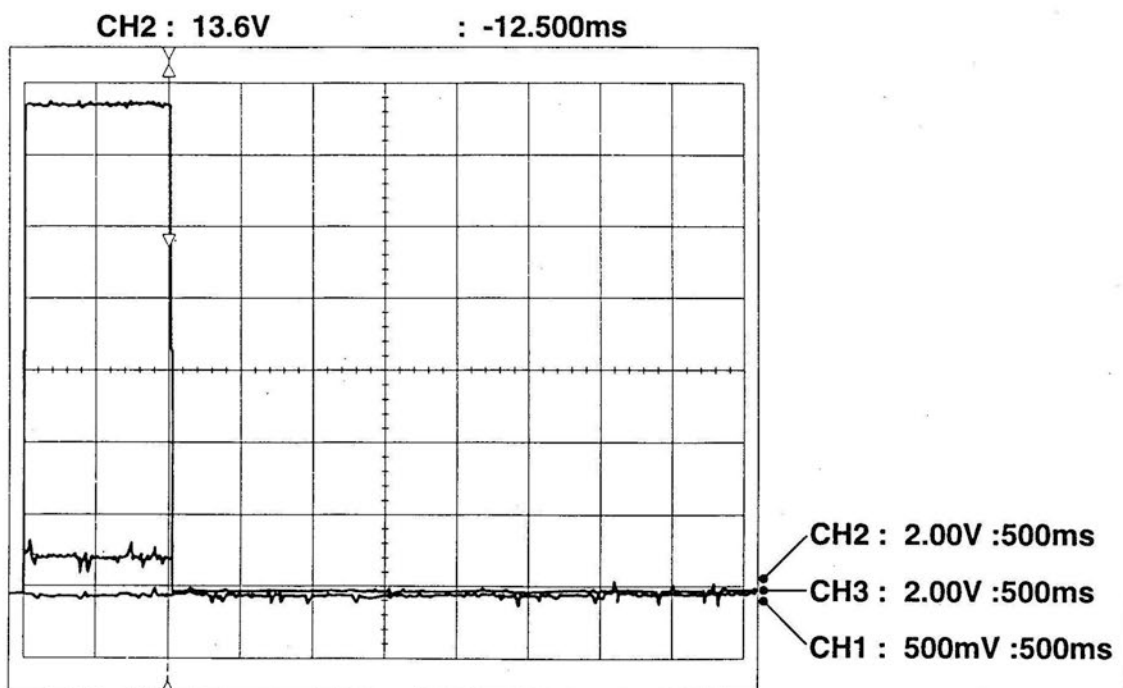

C271W-5571

### Pin 38 — ACC relay

Note: OFF ► ON

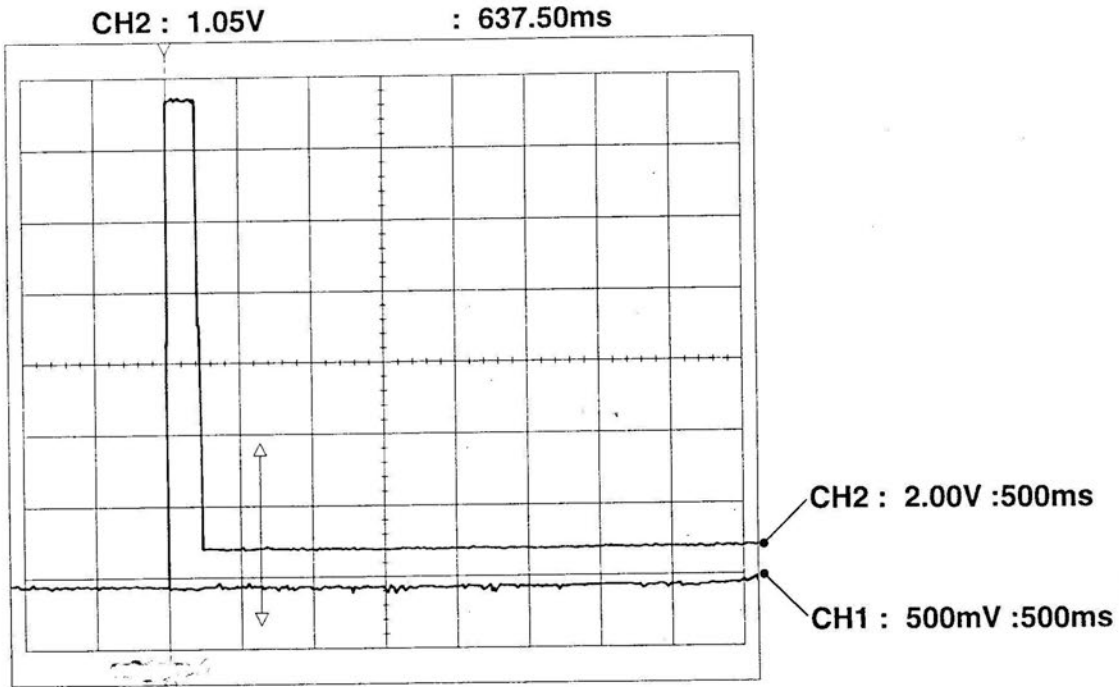

### Pin 38a — ACC relay

Note: ON ► OFF

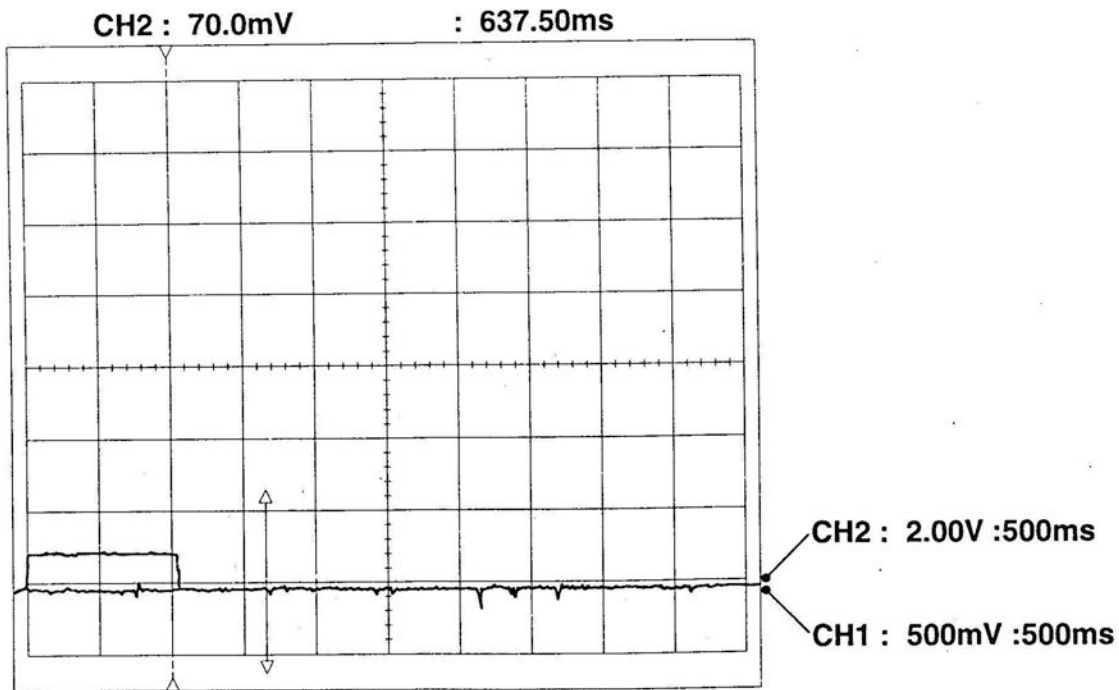

## Calibration

### Kick Down Cable adjustment

#### Important

Basic adjustment of the Kick Down Cable should be carried out **before** calibration.

A modified kick-down cable with no end nipple and improved lubrication was introduced on January 1, 1993 (gearbox No. 174150-). At about the same time (starting with chassis No. P1020737) a reinforced bracket for the KDW motor was also introduced. If this reinforced bracket is used on earlier cars, the omega clip should NOT be fitted.

- 1 Push the lever of the KDW-motor as far away as possible from the cable sheath adjusting clamp.
- 2 Check whether the lever reaches its mechanical stop on the KDW motor at the same time as the cable reaches its mechanical stop in the gearbox. If it does not, go to point 3.
- 3 Loosen the cable sheath clamp and move the sheath until the conditions described in point 2 are met (see Fig.).

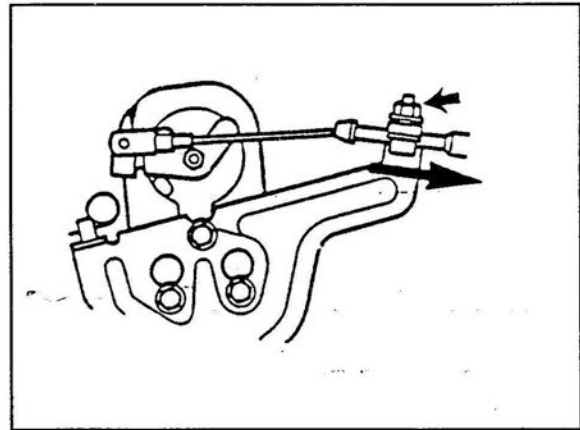
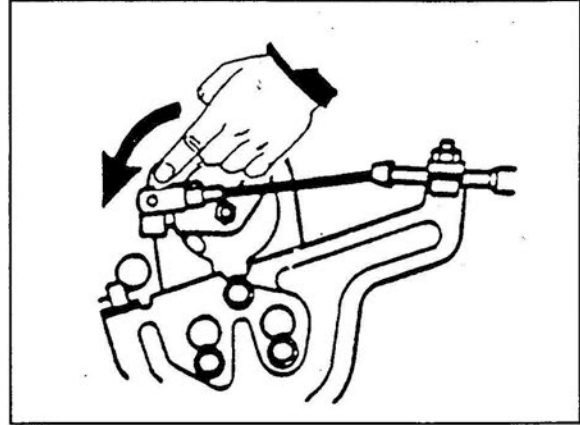

- 4 Check the alignment of the cable and cable sheath. They should be in line.

Adjust the brackets as necessary.

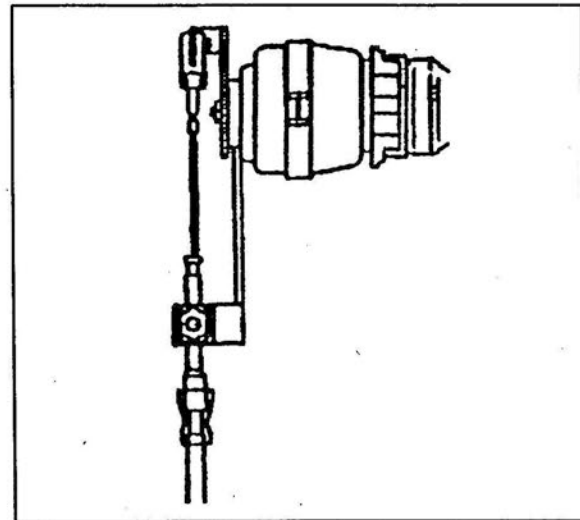

## Calibration (AUT.)

- 1 Plug in a scan tool.

Note and clear the DTCs.

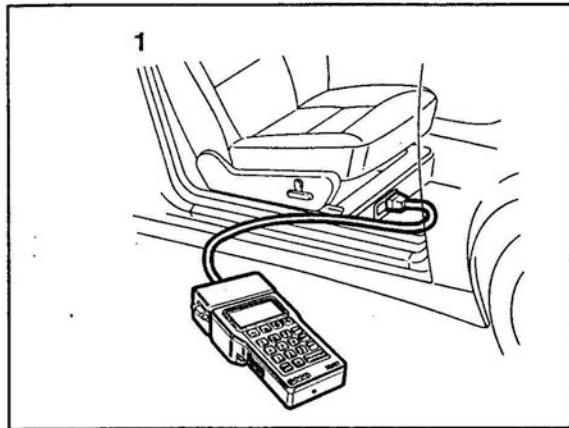

- 2 Run the engine to normal operating temperature.

**Note**

If the engine will not idle, enter scan tool code 974.

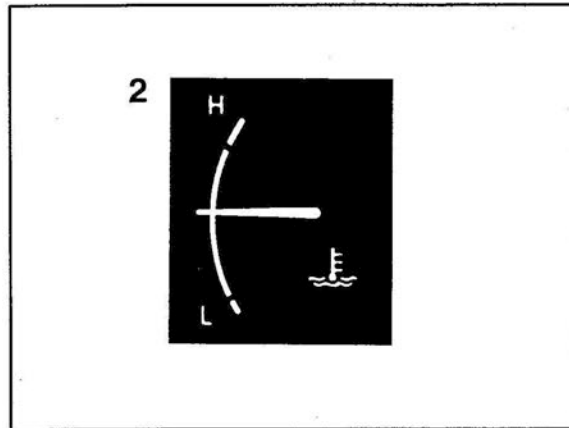

- 3 Enter scan tool code 971 to obtain the base line setting.

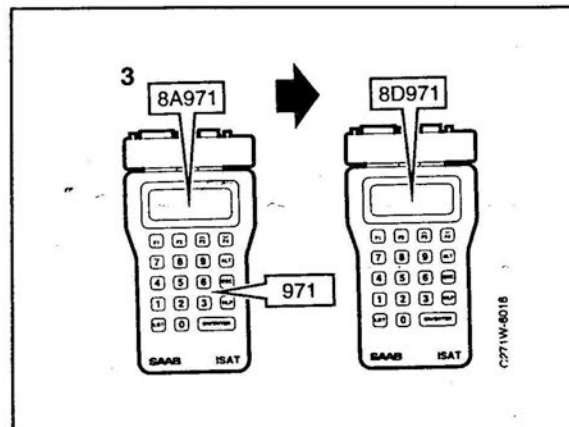

### Calibration (contd.)

- 4 Observe the KDW motor during base line setting (automatic transmission only).

**It should move.**

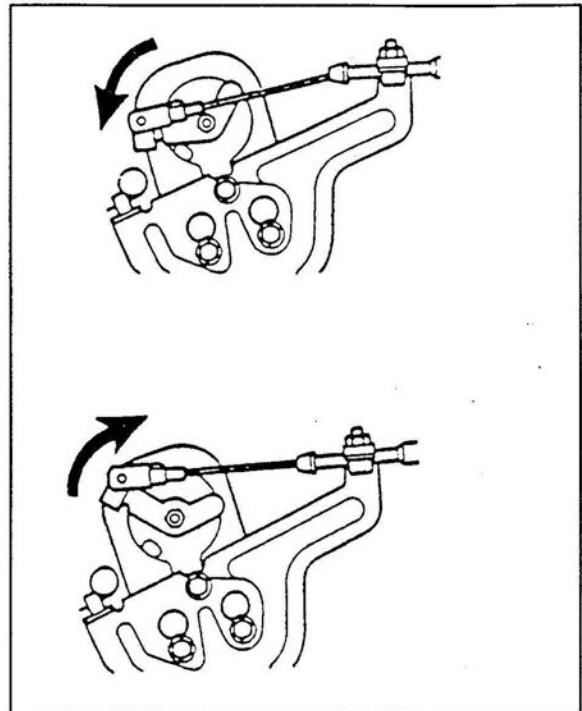

- 5 Enter scan tool code 973, wait for TCS CTRL lamp to light up — and then start the engine.

**Do not touch any other controls.**

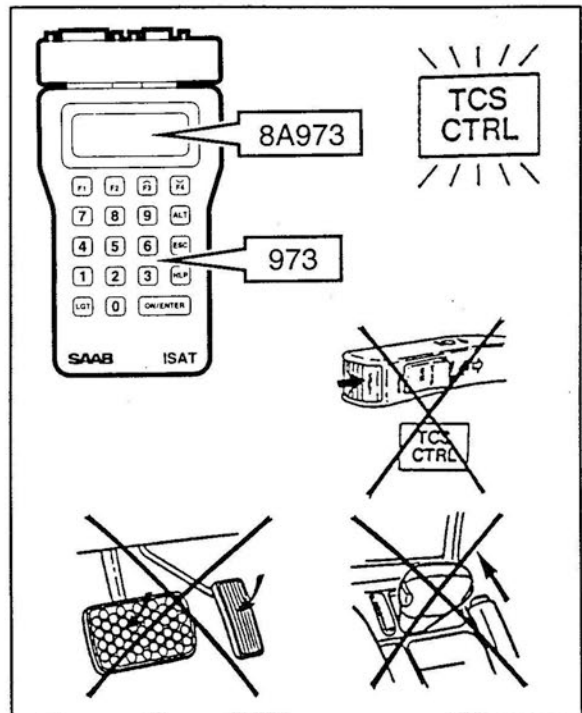

## Calibration (contd.)

- 6 Watch the TCS CTRL lamp (automatic transmission only).

When it flashes, press the Cruise Control "SET" button and keep it depressed until the lamp goes out.

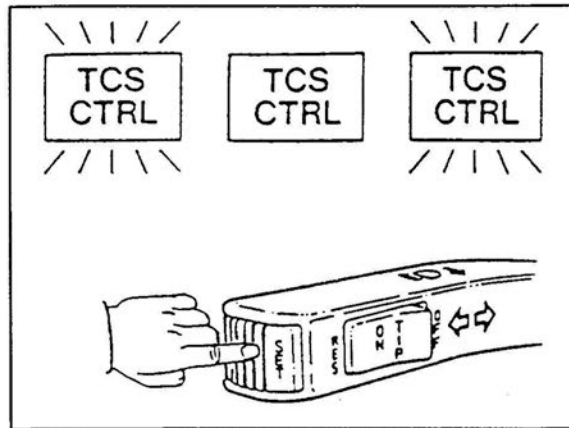

- 7 Engine revs should rise to 3000 rpm and then drop back to idling speed.

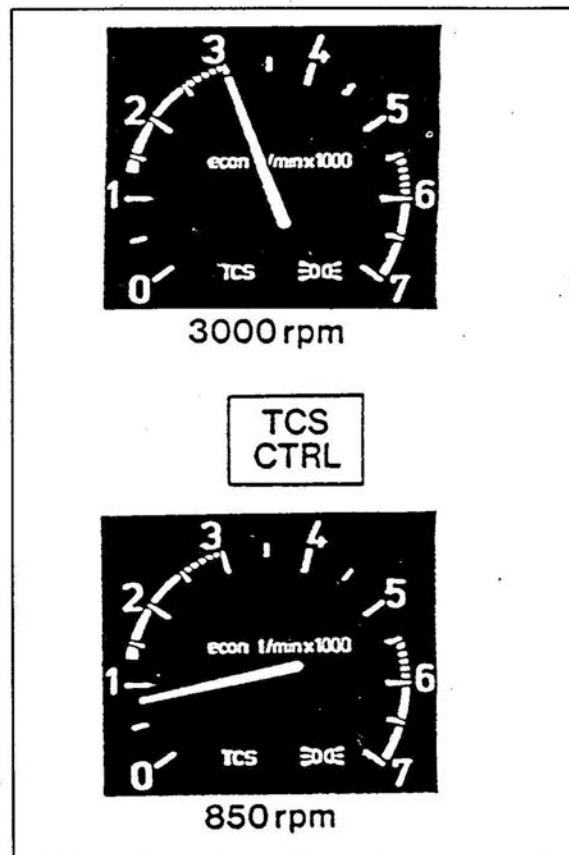

**Remember**  
After calibration always recheck for DTCs.

CALIBRATION COMPLETE

## Final road test

### Road test

Carry out a road test as described in "Road test", see page 8.

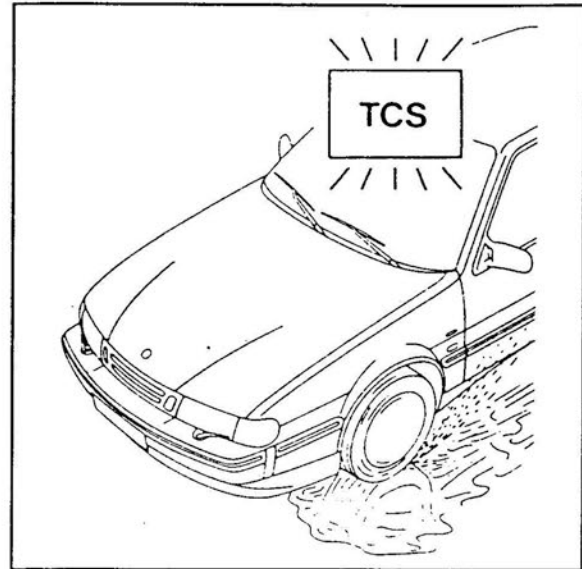

### Recheck for DTCs

Diagnose all systems that can be contacted via both scan tool data link connectors (black and green). No DTCs should appear at this time.

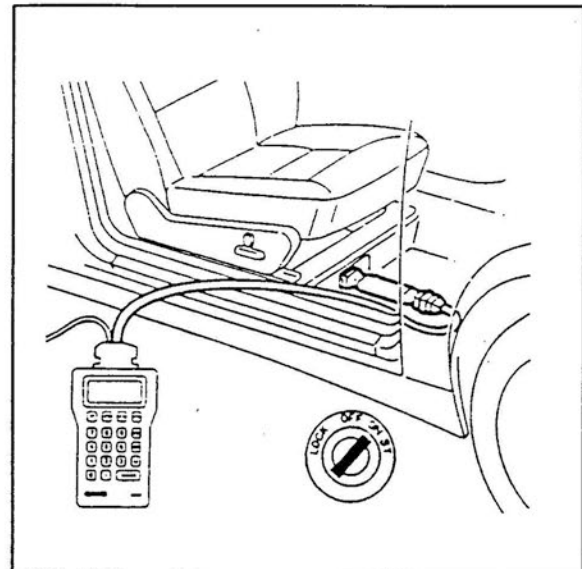

## Inform customer of repairs

Make sure that the customer is told about the nature and extent of the repairs carried out on his car.



C271W-6010



## Wiring diagram for ETS M91 (TCS man.)

### Location of components

22A	Fuse holder behind the access panel in the glove box
29	Brake pedal brake light switch
30	Brake light in rear light cluster
47A	Fuel gauge
47C	Coolant temperature gauge
47U	Cruise Control indicator lamp, US, CA, in main instrument display panel
47Y	TCS warning lamp in the main instrument display panel
132	Sensor for the speed transmitter, in the speedometer in the main instr. displ. panel
133	Clutch switch for Cruise Control, on the clutch pedal
134	Brake switch for Cruise Control, on the brake pedal
141	Selector for Cruise Control, on the direction indicator stalk on the left-hand side of the steering wheel
156	Time delay relay for the radiator fan, AC and ACC, in the main fuse box behind the glove box (22B:E)
200	Control module for the fuel system, in the engine bay on the left behind the bulkhead partition
202	Engine coolant temperature transmitter, on the intake manifold flange between cylinders 1 and 2
228A	Filament monitor in the luggage compartment, on the left hand side by the motorized aerial
269	Multilead connector (2-pole) on pedal switches 133 and 134
347 (H10-8)	Data link connector, engine electronics, under the right-hand front seat (black)
376	ETS electronic control module, under the left-hand front seat
377	Main relay in the main fuse box, behind the glove box (22B:2)
378	Throttle body mounted on the intake manifold
379	Accelerator pedal position sensor, by the accelerator pedal
380	Dump valve for ETS in the engine bay, to the right on the bulkhead partition

381	Charge air bypass control valve in the engine bay, on the left-hand wheel housing adjacent to the battery
H2-21	(RHD) above the pedals by the pedal switches (3-pole connector)
H3-20	Behind the main instrument display panel, by the speedometer (ME)
H24-1	On the bulkhead partition in the engine bay
G3	Grounding points, luggage compartment, by the left hand rear light cluster
G7	Grounding point, at rear of engine, on the sheet steel bracket below the intake manifold
G8	Grounding point, dashboard, by the front left-hand loudspeaker socket
G24	Grounding point, on the right-hand front seat member
G29	Grounding point, luggage compartment, by the right-hand rear light cluster



Wiring diagram for ETS M92 - M93 (TCS aut.)

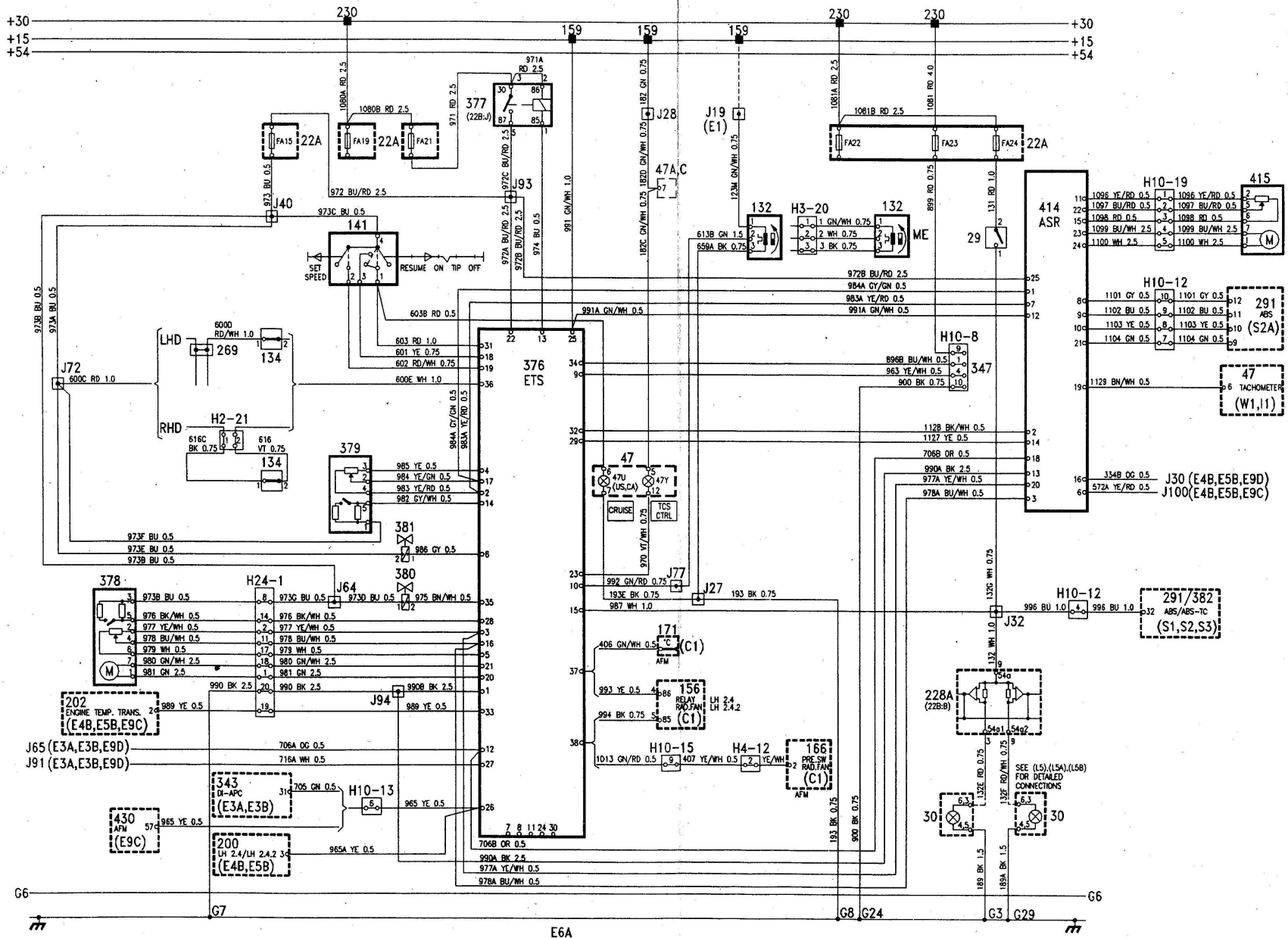

Wiring diagram for ETS M92 – M93 (TCS man.)

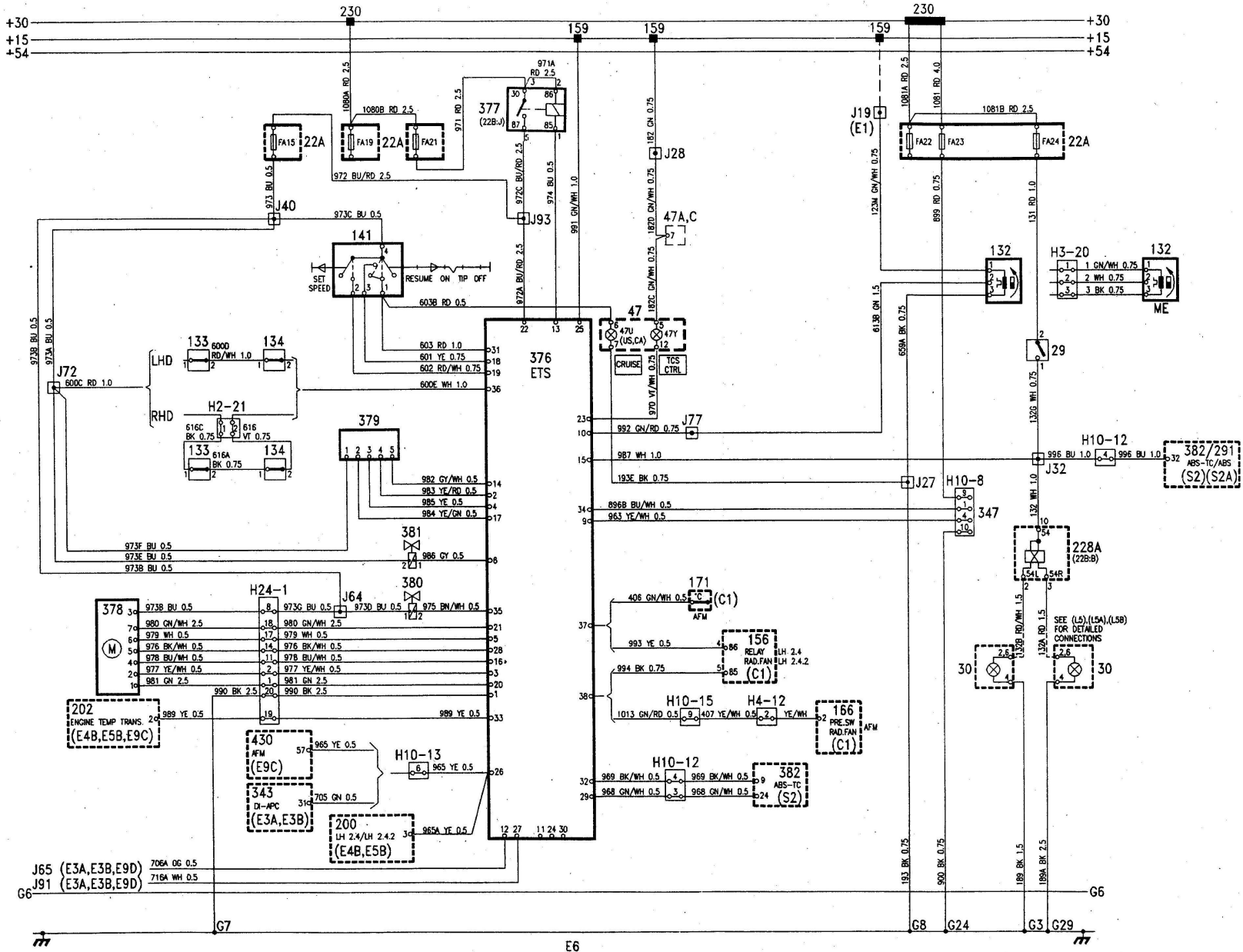





**SAAB**

Saab Automobile AB, Trollhättan, Sweden

ENG

Ordering No. 350461. English edition. Printed in Sweden. © Saab Automobile AB 1996.

jxh

Saab 9000