

SAAB

9000

**SERVICE
MANUAL**

Preliminary Issue

8 :3 ACC Version 2

Introduction	1
Inputs	2
Outputs	3
User Programmed Mode	4
Wiring Diagram	5
Fault Finding	6 – 7
Fault Codes	8
ISAT Command Codes	9
Key to Troubleshooting Information	10
Power Supply Check	11
Solar Sensor Check	12
Outside Temperature Sensing Check	13
Mixed Air Temperature Sensor Check	14 – 15
Inside Air Temperature Sensor Check	16 – 17
Temperature Sensor Inside Fan Check	18
Common Sensor Ground Fault	19 – 20
Temperature Control Flap Motor Check	21 – 22
Distribution Flap Motor Check	23 – 24
Recirculation Flap Motor Check	25
Ventilation Fan Check	26 – 27
Rear Door Fans Check	28
Rear Window and Outside Mirror Heaters Check	29
Air Conditioning Unit Wiring Diagram	30

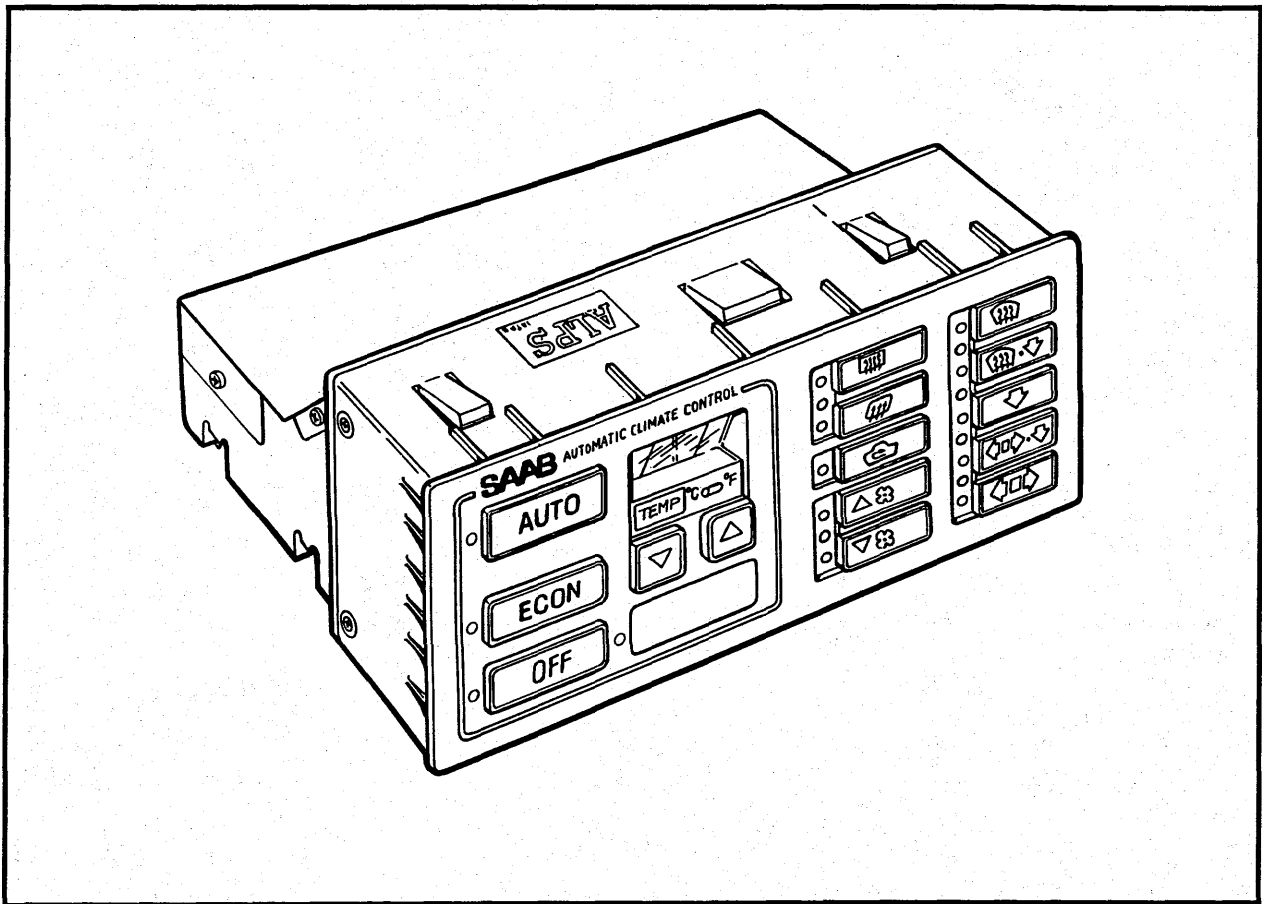

ACC2 is a further development of ACC1. The new system is equipped with better sensors and more accurate flap control to provide improved standards of comfort and quieter operation.

An interesting innovation exclusive to SAAB is the new solar sensor (world patents pending) which is fitted on top of the dashboard. In addition to measuring the infra-red radiation to calculate sun intensity, the new sensor also detects the angle of elevation and bearing of the sun.

The program memory of the microprocessor has been expanded to provide the following:

- More accurate and faster control of the compartment climate.
- New drive motors for the heater and air distribution flaps which are much quieter in operation and permit more accurate control of the positions of the flaps.
- Front panel text changed to symbols for easier reading and a new facility enabling the driver to switch off the unit.

Inputs

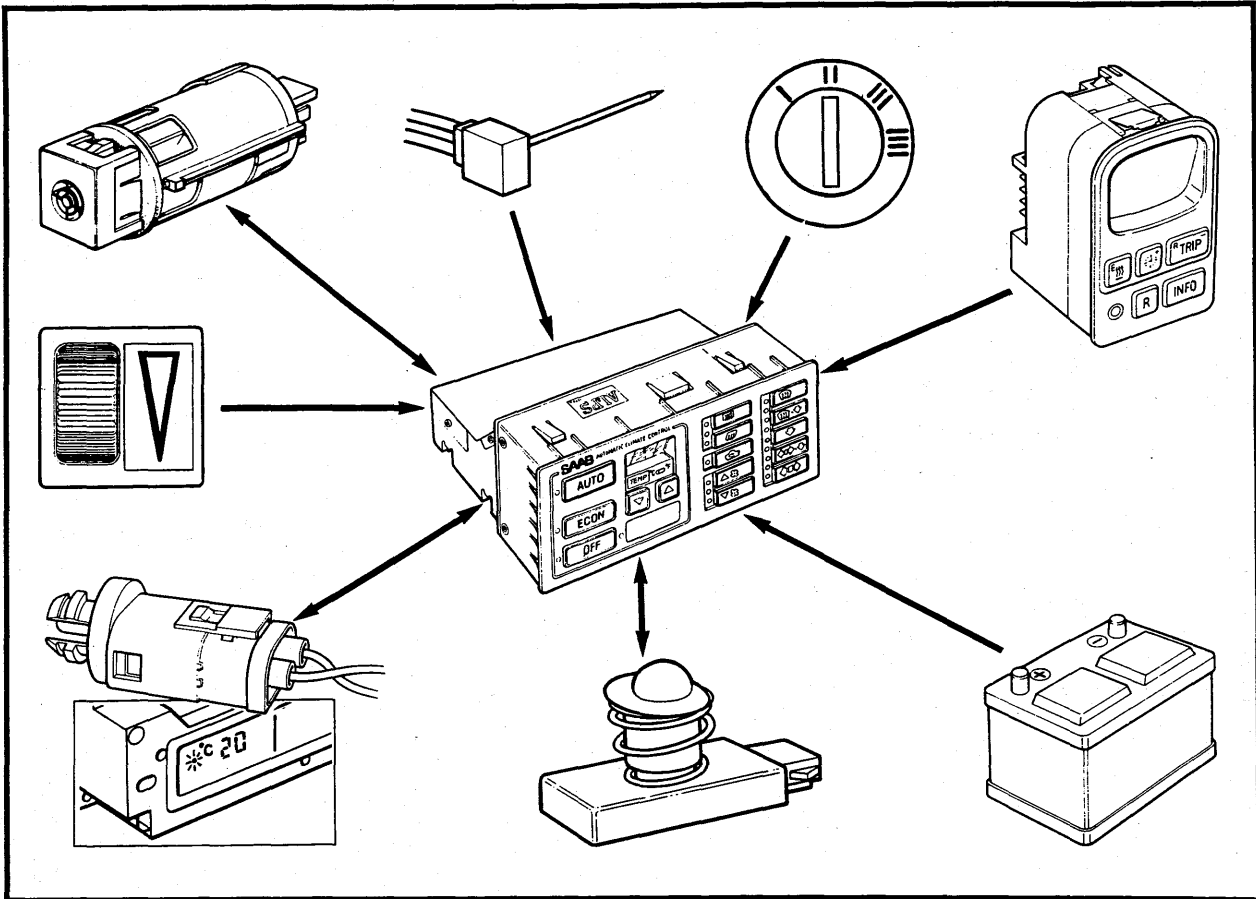

The temperature indication signals from the indoor and mixed air temperature sensors are DC signals proportional to temperature. The indoor sensor also receives a supply for the induction fan which sucks air through the sensor.

The solar sensor input is also an output since it is a serial data link providing 2-way communication between the microprocessors used in the solar sensor and ACC unit.

The battery +30 supply provides the main power for the unit and the +54 ignition supply is used to switch on the unit.

The outside temperature signal from the EDU comprises blocks of pulses in which the number of pulses is proportional to temperature. Consecutive blocks are separated by a gap of at least 400mS.

The rheostat supply is used for the pushbutton lamps and during darker conditions also supplies the LED indicators.

Outputs

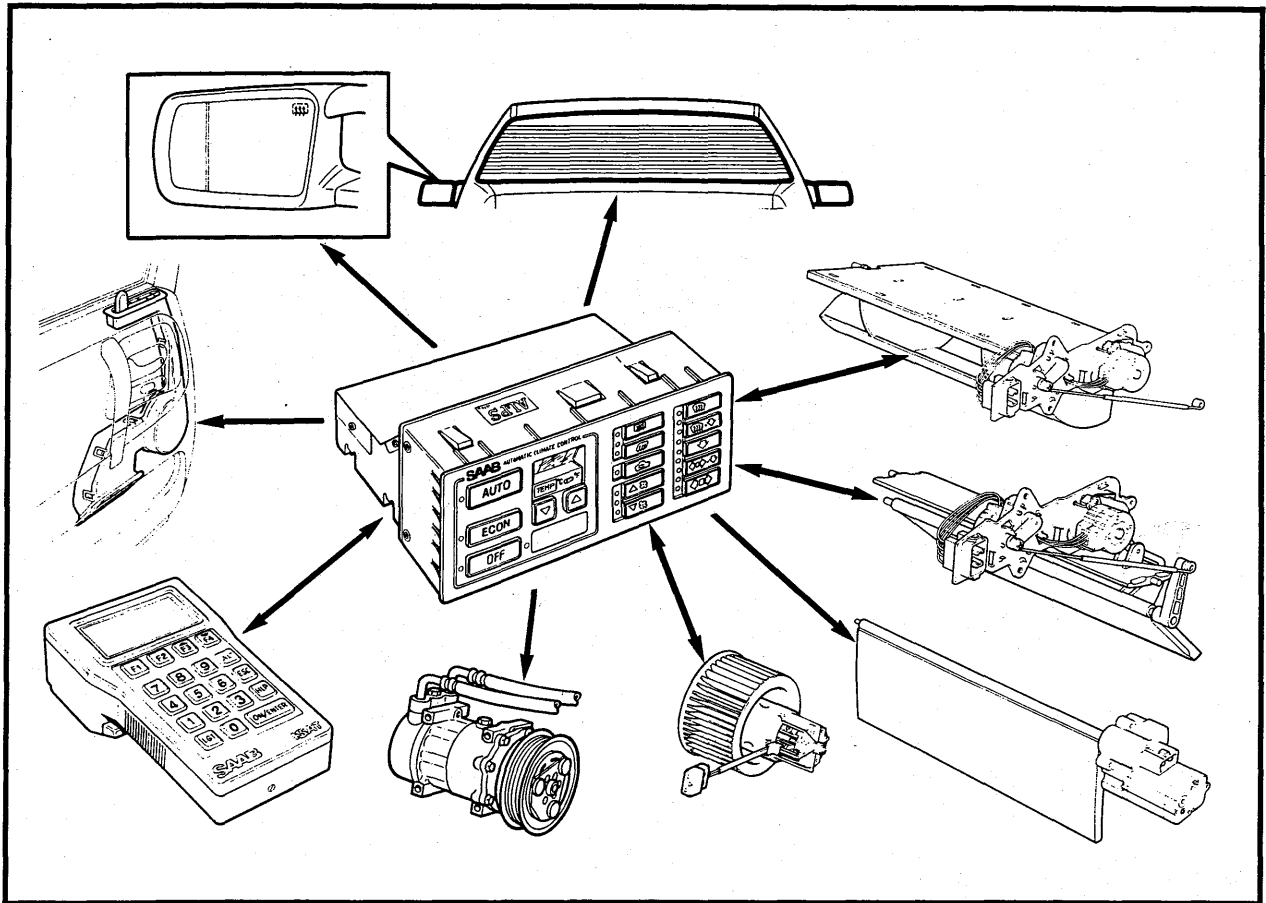

The AC output and the output to the rear window and mirror heater are 12V signals to operate relays. (On some models the AC output signal goes to the LH control unit.)

The ISAT output and input provides the communication between the ACC and ISAT microprocessors.

The remaining outputs are all motor drives as follows:

Ventilation fan: Variable 0 to 5V DC signal to the fan control unit. The fan feedback signal is a 1 to 12V DC signal proportional to the speed of the fan.

Air recirculation flap: Reversible constant speed DC drive.

Temperature control flap: Pulses for setting positions of the stepping motor.

Air distribution flap: Pulses for setting positions of the stepping motor.

Rear door fans: Variable speed 7 to 11V DC drive.

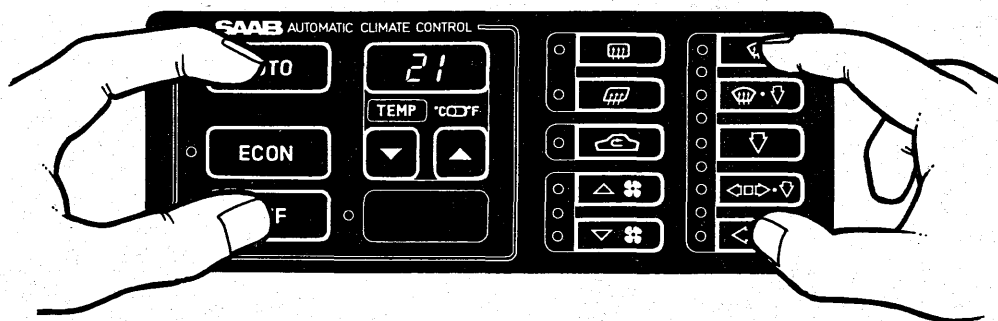

Erase Programme

Programme

The ACC unit can be programmed to start with preset manual selections active as follows:

- Make the required selections using the manual controls.
- Operate the DEF & VENT pushbuttons at the same time for at least 20 mS.

The temperature display extinguishes for a short period confirming selection.

Control continues with chosen selections active and the selections are automatically implemented when the ignition is switched on, provided the ignition has been switched off for more than 30 seconds.

Following start, the selections remain active until cancelled by the AUTO, ECON or OFF pushbuttons or different manual selections are chosen using the other manual controls.

The programmed selections are cancelled by pressing the AUTO & OFF pushbuttons for a further 20 mS.

The selections can be changed at any time by repeating the programming procedure.

Introduction to ACC 2



Wiring Diagram

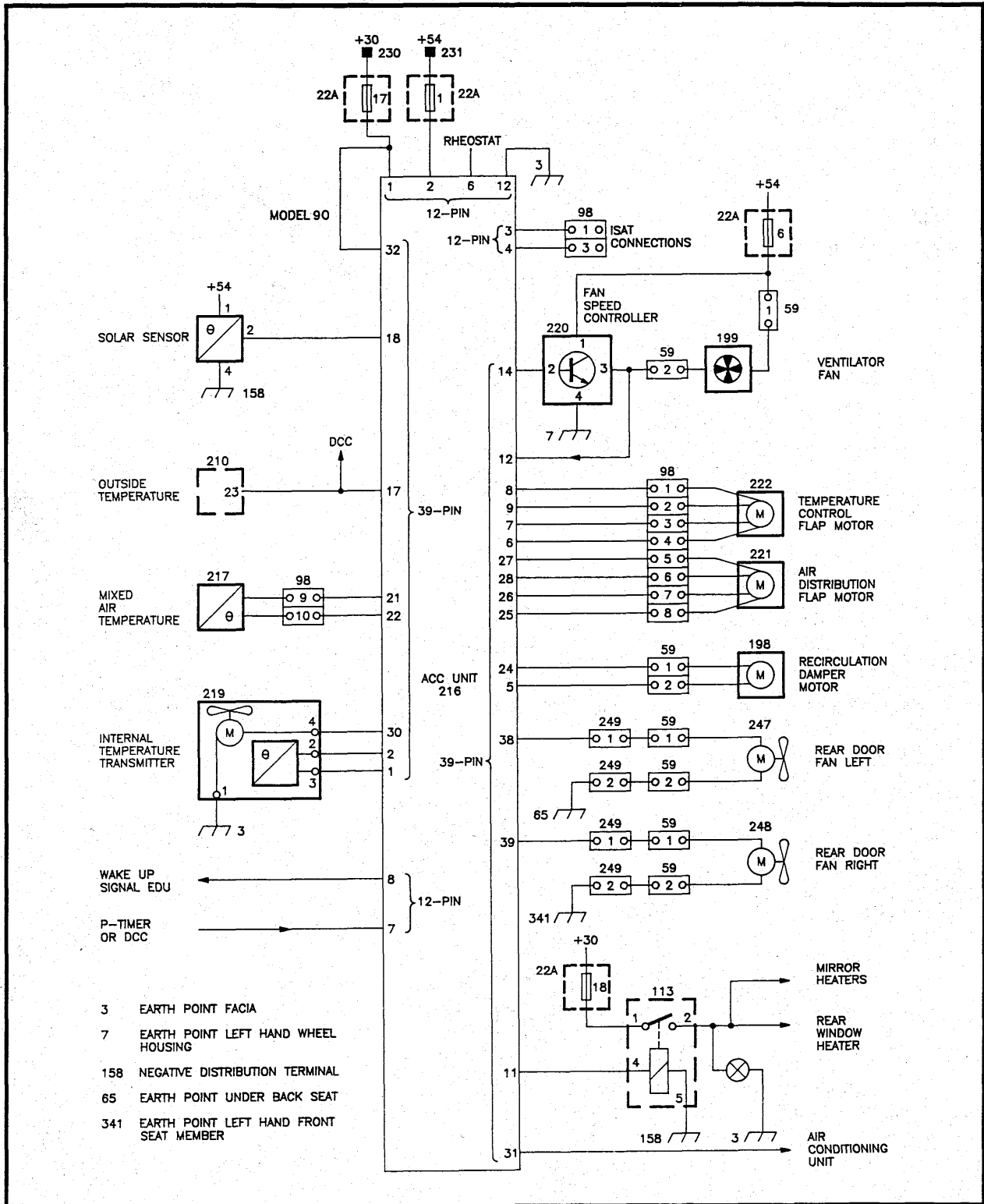

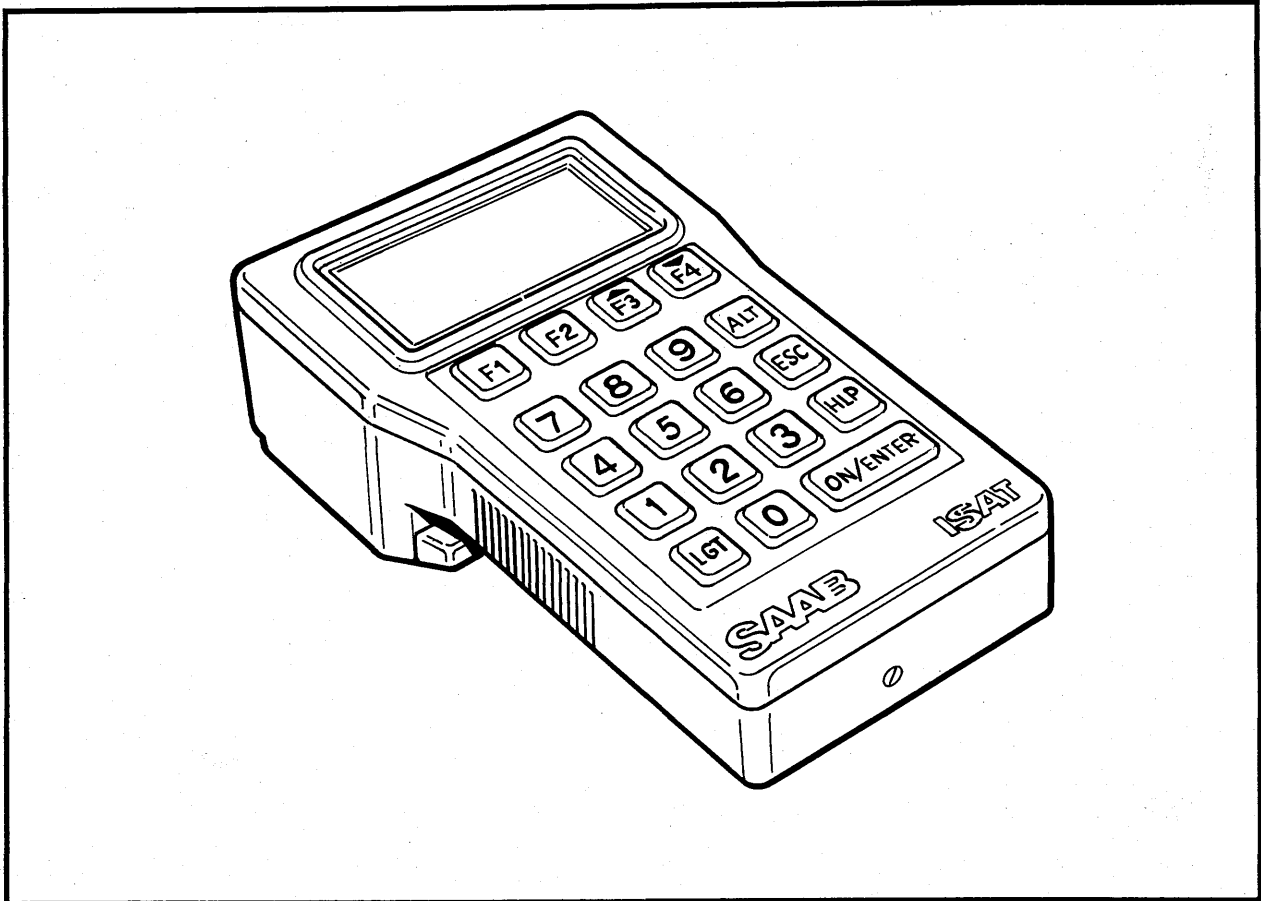

The ACC is System No. 2 on the ISAT tester. Use ISAT first to record all faults.

A self test program is integrated with the ACC program and carries out checks while the unit is operating. This program also runs when the ignition is first switched on, either when selected by pressing the AUTO & VENT push buttons, or under the control of ISAT. For a complete self test and calibration this program must run for 35 seconds.

Any faults detected by the self test program are allocated a fault code indicating the type of fault. When the ignition is first switched on the number of faults detected is displayed in the ACC temperature display while the self test program is running. It is also possible to see faults displayed by pressing OFF and then AUTO.

The recorded fault codes are read from the ACC memory using ISAT. They can be erased by using ISAT's RESet function, or with command code 900.

NOTE: Throughout this manual the British term "earth" is used in place of "ground."

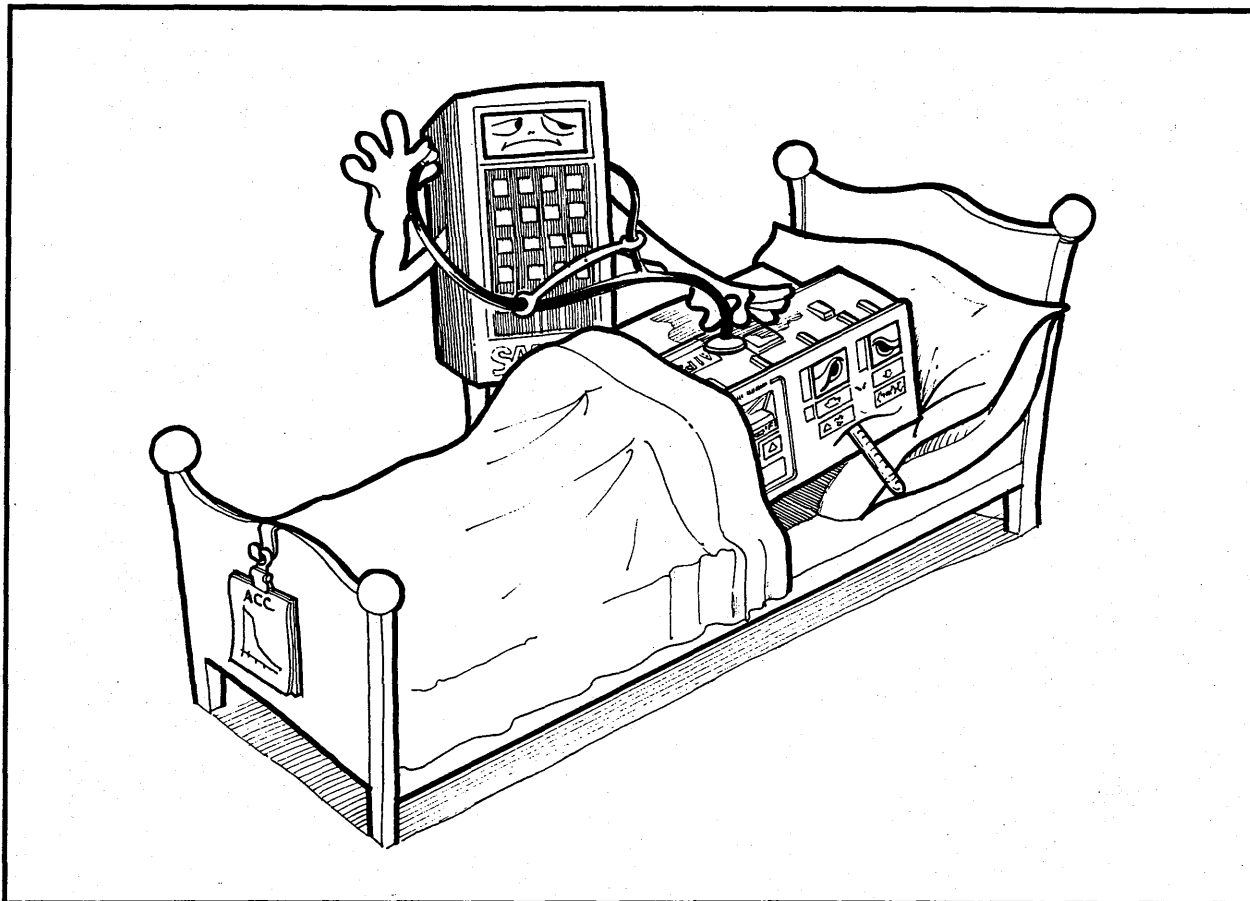

Points to note:

When fault finding on microprocessor systems the memory may become corrupted causing unusual symptoms. To clear any strange symptoms switch the ignition off for at least 35 seconds.

Read and record fault codes before disconnecting the battery or ACC control unit.

When fault finding on car electronics, it is always good practice to first check that the earth connection to the unit is sound and the power supplies are correct.

ALWAYS CHECK THE CONNECTIONS AT PLUGS AND SOCKETS BEFORE FAULT FINDING IN OTHER AREAS. DISCONNECT THE PLUGS AND INSPECT THE PINS FOR DAMAGE. REFIT THE PLUGS, CLEAR ALL FAULT CODES THEN RUN THE SYSTEM AND CHECK IF THE

FAULT IS STILL PRESENT.

When first detected all fault codes are permanent. The code changes to intermittent when the fault disappears. Fault codes can be erased either by ISAT/command code 900 or by using ISAT's RESet function.

The voltage levels given in the signal level tables are all measured using a Digital multimeter.

Signal voltages of 12V listed in the following tables are approximate. The condition and charge of the vehicle battery will affect this reading and slight differences from 12V should be considered normal.

Also note that the 0V readings listed may register slightly above 0V on a sensitive digital multimeter.

Note: All measurements must be carried out from behind the plugs or sockets. Voltage measurement of inputs or outputs must be made with ignition on or engine running.

Introduction to ACC 2



ISAT Command Codes

ISAT Command Codes	ISAT Display Shows
27A *	Desired position of temperature flap motor. 0% (LO) - 100% (HI)
27B *	Desired position of distribution flap motor 45° (vent) - 135° (DEF)
279	Desired position of recirculation flap motor. Fresh air or recirculation.
380	Type of solar sensor. Standard or Australian.
229	Battery voltage ACC unit. Voltage range 0 - 26.5 V.
22A *	Ventilation fan control signal. 0 - 5 V.
270	Illumination level control of LED's by photo-transistor. 0% (dark) - 100% (bright)
251	Outside temperature by EDU. -44°C - +50°C.
252	Mixed air temperature. 0°C - +80°C.
250	Indoor temperature. +10°C - +40°C.
100	Send all stored fault codes.
800	End of communication.
900	Clear all stored fault codes.
960	Starting self test on the ACC-system, and calibration of flap motors. All earlier stored faults will be erased.

NOTE! Command codes 27A, 27B and 279 are desired positions of the motor. This means that you will never know if the motor really moved to the required positions. The only way to be sure is to carry out a visual check.

ISAT will read out voltage, change in flap position, etc. You must use the control buttons on the ACC unit to move the flaps, change fan speed and so forth. The individual troubleshooting procedures will provide instructions.

* See P. 10 for information on entering command codes that contain a letter.

Introduction to ACC 2



Key to Troubleshooting Information

Fault Codes		Fault
Permanent	Intermittent	
46323	26323	Inside air temperature sensor open circuit or 12V at pin 1 of the ACC unit or a fault in the ACC unit fault monitoring circuit.

ISAT Command Codes	Display Shows
250 *	Indoor temperature. +10°C - +40°C.

If Display Shows	Possible Fault
+18°C	: Open circuit pin 1 or 2. : Battery voltage pin 1. : LED's dim --- battery voltage pin 2 (see p. 19).
+40°C (Cold air)	: Bridged pin 1 and 2. } No fault code. : Pin 1 at earth.

The following pages present fault code, command code and troubleshooting information as presented in the box above. Listed below is an explanation and guide for using this information.

Fault Codes: Lists the permanent and intermittent fault codes that will be shown by the ISAT tester after performing a system diagnosis.

Fault: A description of the problems that can trigger the fault code(s) to be displayed.

ISAT Command Codes: This is the command code that should be entered into ISAT to further investigate a fault.

Display Shows: This is the information the ISAT display will show after you have entered the command code.

If Display Shows and Possible Fault: These two columns will show different faults that may be present depending on the values shown by the ISAT display after the command code is entered.

* To enter a command code that contains a letter, i.e. 27A, press the F1, F2, F3, or F4 button under the appropriate letter at the bottom of the ISAT command code screen.

Introduction to ACC 2



Power Supply Check

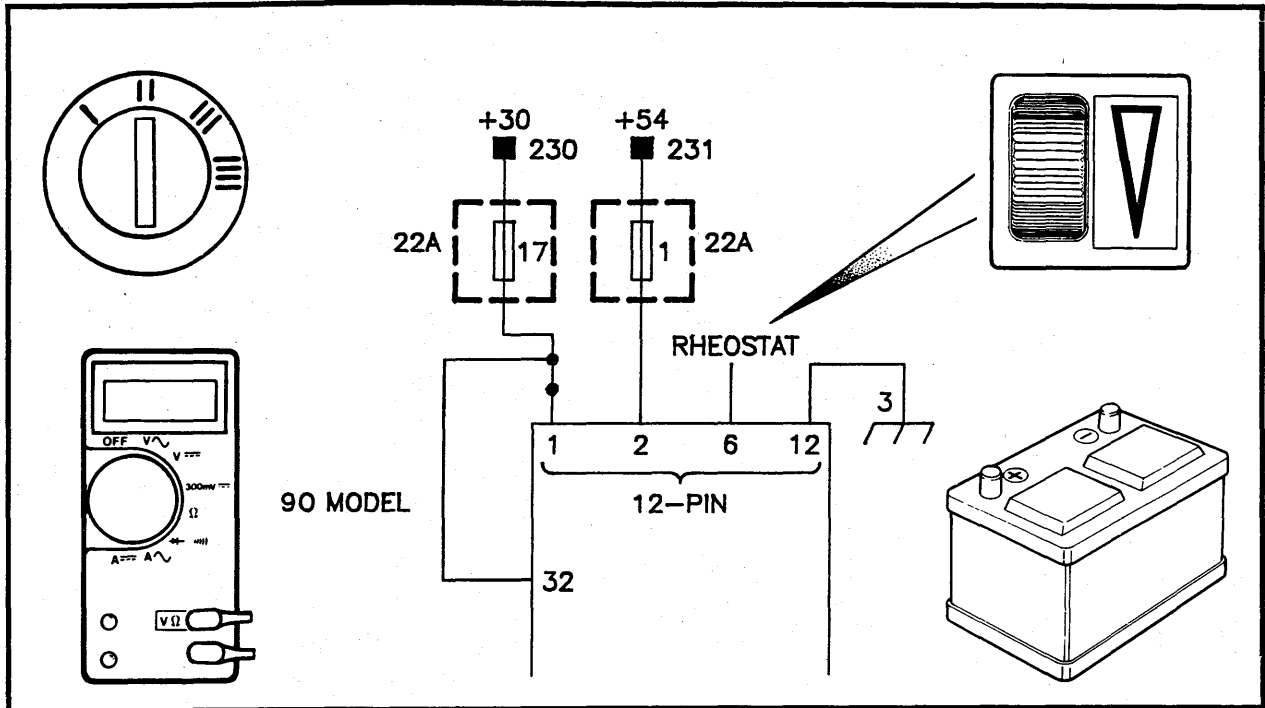

ISAT Command Codes	Display Shows
229	The battery voltage in the ACC unit. Voltage range 0 - 26.5 V (the voltage in the ACC unit is always 1V below the battery voltage).
270	Illumination level control of LED's by photo-transistor. 0% (dark) - 100% (bright)

Use a finger and place it on the photo transistor.
Display shows percentage close to zero and the LED is dim.

Use a light and shine it on the photo-transistor.
Display shows a higher percentage and the LED's are brighter.

1. Disconnect the 12-pin plug (58) and check for earth continuity at pin 12.
2. Check the +30 supply across pins 1 and 12 of the 12-pin plug (58).
3. Check the +54 supply across pins 2 and 12 of the 12-pin plug (58).

Signal levels

Signal Measured	ACC Pins	Condition	Voltage
+30	1 & 12 (58)	Normal	B-voltage
+54	2 & 12 (58)	Normal battery voltage	(9 to 16V)
Rheostat	6 & 12 (58)	Normal	0 to 12V

NOTE: If the supply voltage goes outside the limits of 9 to 16V, the OFF LED will light and the display will go blank. If this happens and there is no apparent problem with the charging system, check the EDU voltage reading calibration.

Introduction to ACC 2



Solar Sensor Check

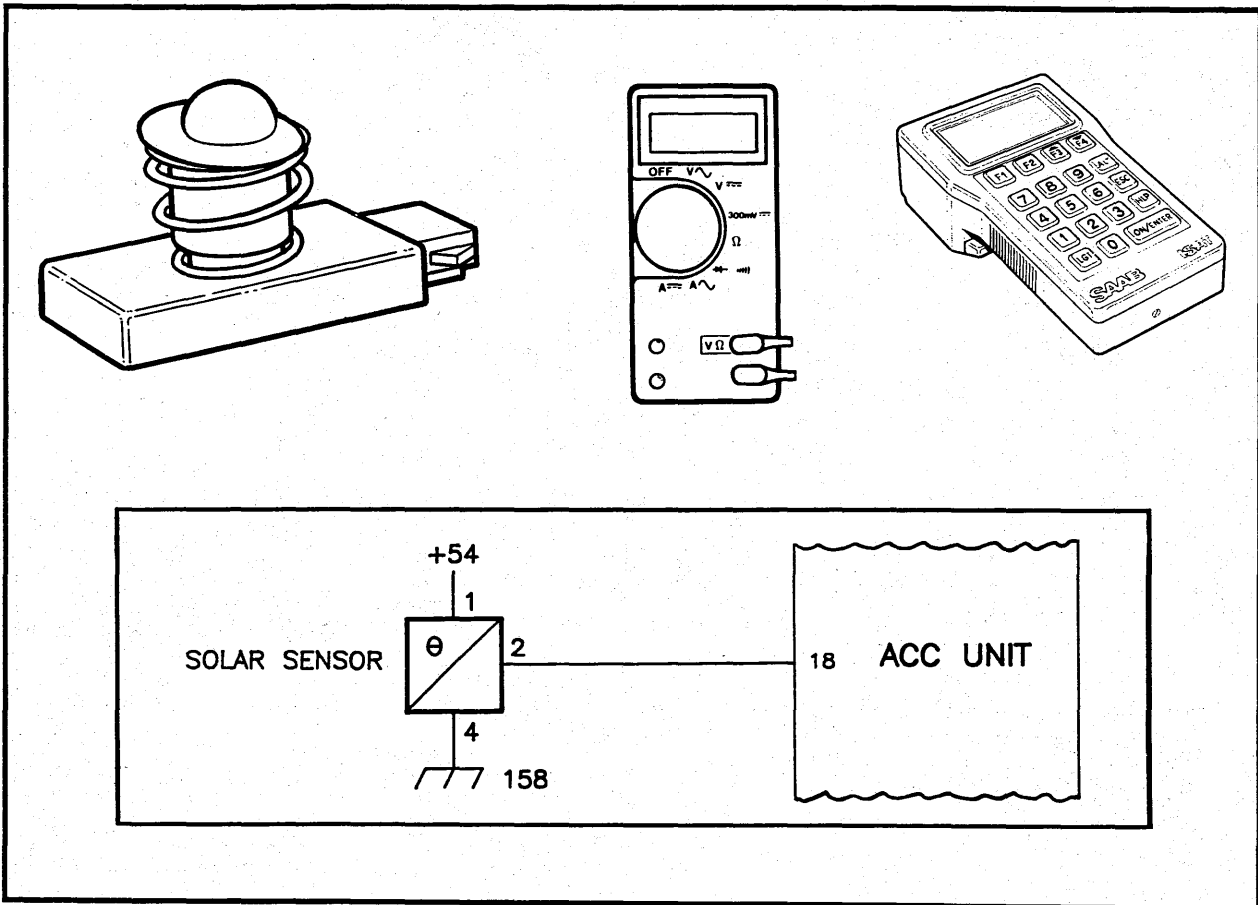

Fault Codes		Fault
Permanent	Intermittent	
66891 E6891	D6891	Solar sensor hardware fault. Solar sensor communication fault. The fault may be open circuit, short circuit to earth, or short circuit to 12V (pin 18).

ISAT Command Codes	Display Shows
380	Type of solar sensor. Standard or Australian.

1. Disconnect the solar sensor plug and check the earth at pin 4 and the +54 supply at pin 1. If incorrect check the wiring. If correct refit the plug, clear any fault codes and run the system.
2. If a fault is still present, disconnect the solar sensor and the 39-pin ACC unit plugs. Check the continuity between pin 2 of the sensor plug and pin 18 of the ACC unit plug. If normal, refit the plugs, clear any fault codes and run the system.
3. If a fault is still present, try a new solar sensor and run the system.
4. If a fault is still present, refit the old sensor and try a new ACC unit.

Outside Temperature Sensing Check

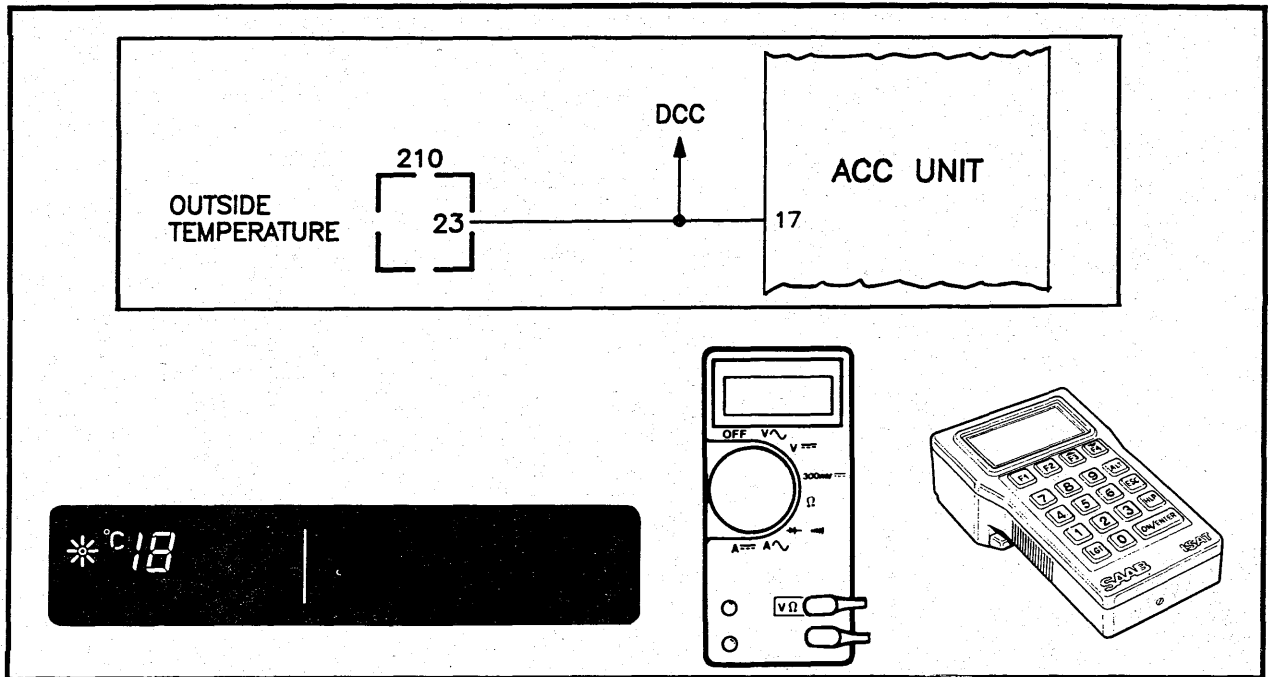

Fault Codes		Fault
Permanent	Intermittent	
46391	26391	No outside temperature pulses from the EDU.

ISAT Command Codes	Display Shows
251	Outside temperature by EDU. -44°C - +50°C.

If Display Shows	Possible Fault
Fixed Reading (locked on last temperature display), fault occurs while driving. -44°C, fault exists before starting car.	: Open circuit or battery voltage on pin 17. : Open circuit or battery voltage on pin 17 when starting the engine. : Earth on pin 17. : Fault in the EDU or ACC.

BEFORE CARRYING OUT THIS CHECK ENSURE OUTSIDE TEMPERATURE SENSING BY THE EDU IS OPERATING NORMALLY. CHECK ALSO (IF DCC FITTED) FOR FAULT CODE F2.

1. Disconnect the EDU and ACC unit plugs and check for continuity between pin 23 of

the EDU and pin 17 of the ACC unit 39-pin connector. If normal, refit the plugs, clear any fault codes and run the system.

2. If a fault is still present, try a new EDU.
3. If this fails to clear the fault, refit the old EDU and try a new ACC.

NOTE: Servicing the EDU using ISAT will frequently set this fault code without any actual fault existing in the ACC. Erase the fault code and re-test before beginning any diagnostic procedures on the ACC.

Introduction to ACC 2



Mixed Air Temperature Sensor Check

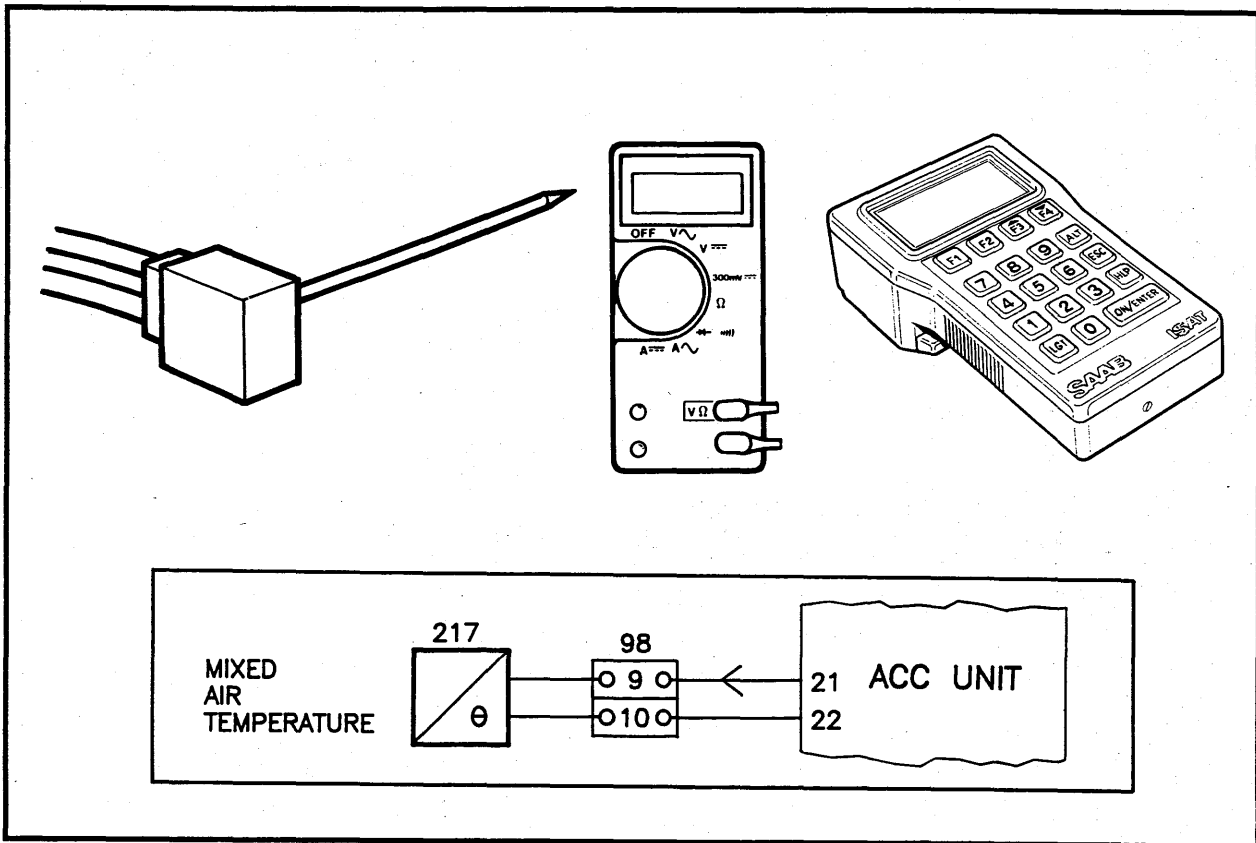

Fault Codes		Fault
Permanent	Intermittent	
46322	26322	Mixed air temperature sensor open circuit or 12V at pin 21 or a fault in the ACC unit monitoring circuit.

ISAT Command Codes	Display Shows
252	Mixed air temperature. 0°C - +80°C.

If Display Shows	Possible Fault
Set temperature of +50° C (version 2.00) Calculated set value by ACC (version 2.01) +50° C (version 2.00) Calculated set value by ACC (version 2.01) +80° C (version 2.00 and version 2.01)	: Open circuit at pin 21 or 22. : If LED's are dim, then battery voltage is at pin 22 (see p. 19). : Battery voltage on pin 21. : Bridge between pin 21 and 22. : Pin 21 at earth.
	} No fault code.

* NOTE: This test cannot be carried out below 32°F (0°C).

Introduction to ACC 2



Mixed Air Temperature Sensor Check

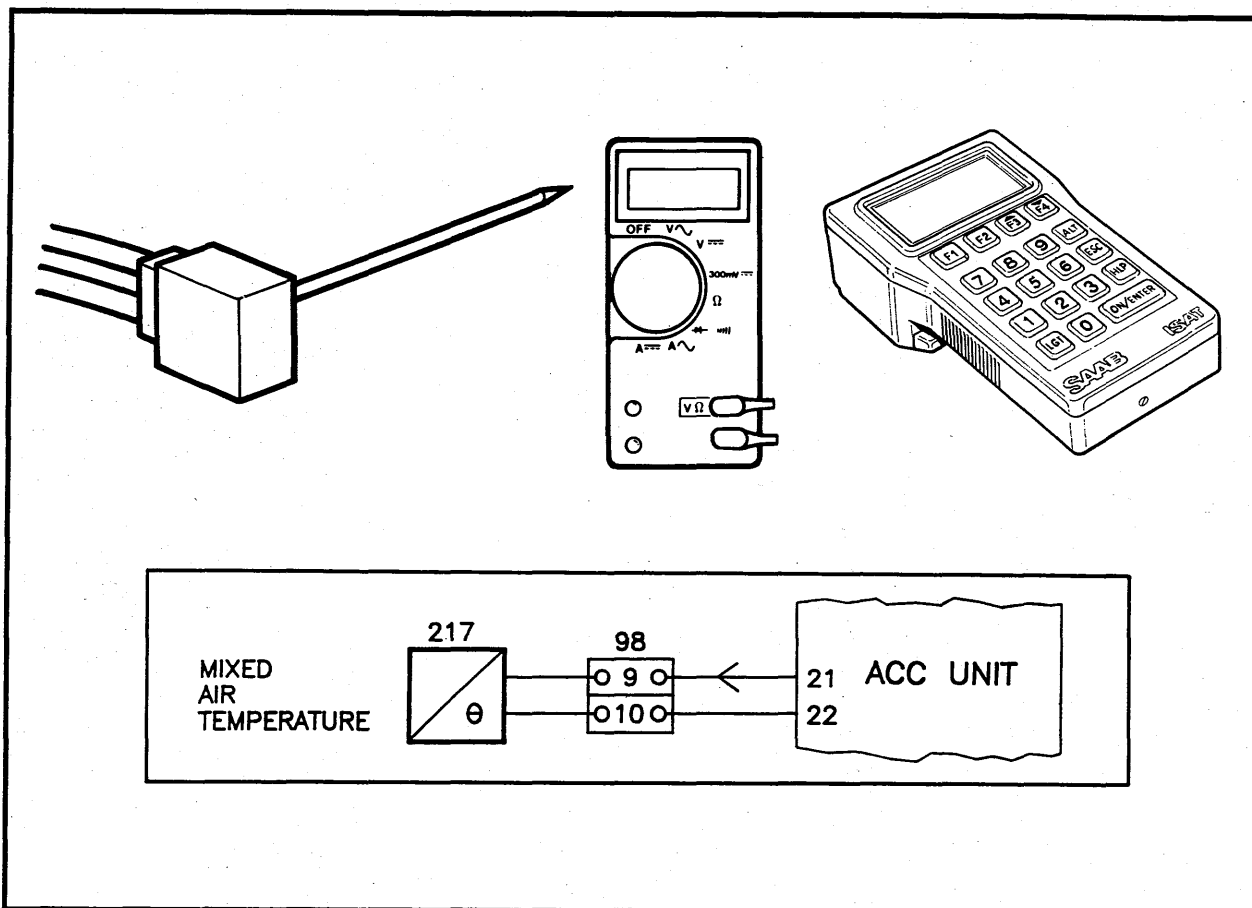

1. Disconnect the ACC unit 39-pin plug and check the resistance value across pins 21 and 22. The value varies between 1 and 240 kohms over the range +90 to -40°C. Values at particular temperatures are:

	Minimum (kohms)	Maximum (kohms)
0°C	25.5	30.5
+10°C	16.6	19.6
+20°C	11.2	13.0
+30°C	7.7	8.8
+40°C	5.4	6.1

2. If the value is incorrect, disconnect the temperature sensor plug and repeat the resistance check across pins 9 and 10 of the plug. If the value is still incorrect, fit a new temperature sensor.

3. If the value measured across the temperature sensor plug is correct, check for continuity between plug 98 and ACC unit (pins 9 and 21, pins 10 and 22). If the wiring is normal, refit the plugs, clear any fault codes and run the system to determine if a fault is still present.

4. If a fault is still present, measure the voltage at pin 21 of the ACC unit. This will vary depending on the sensor resistance value and the battery voltage according to the following formula: (Measure with the ACC plugged in and ignition ON).

$$\frac{(B\text{-volts} - 1.5) \times R\text{-sensor}}{R\text{-sensor} + 10 \text{ kohms}}$$

5. If the voltage is incorrect, try a new ACC unit.

Introduction to ACC 2



Inside Air Temperature Sensor Check

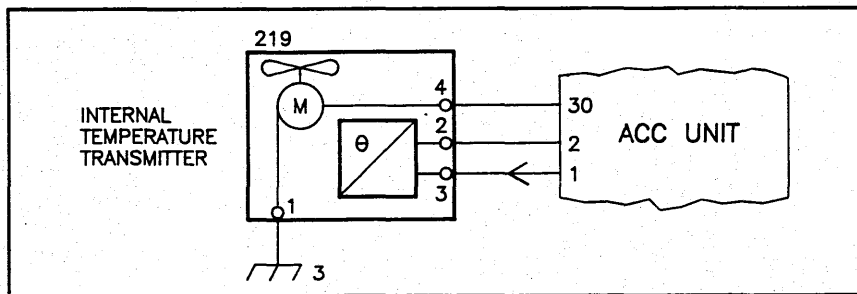
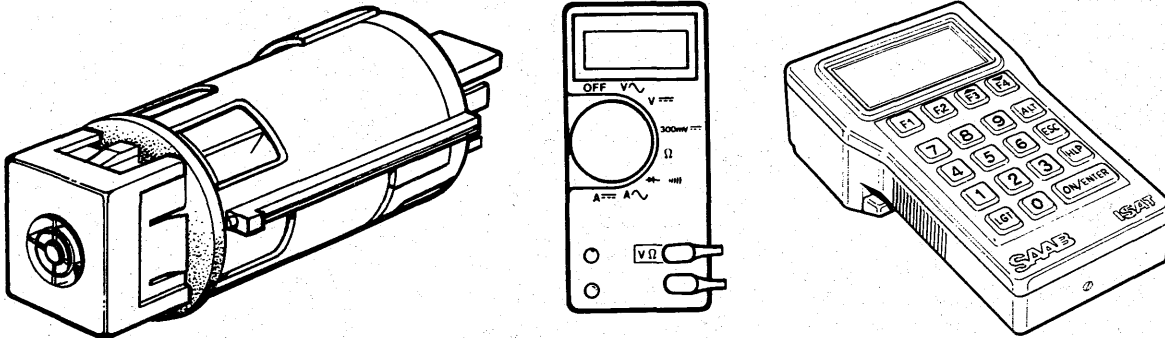

Fault Codes		Fault
Permanent	Intermittent	
46323	26323	Inside air temperature sensor open circuit or 12V at pin 1 of the ACC unit or a fault in the ACC unit fault monitoring circuit.

ISAT Command Codes	Display Shows
250	Indoor temperature. +10°C - +40°C.

If Display Shows	Possible Fault
+18°C	: Open circuit pin 1 or 2. : Battery voltage pin 1. : LED's dim --- battery voltage pin 2 (see p. 19).
+40°C (Cold air)	: Bridged pin 1 and 2. : Pin 1 at earth. } No fault code.

NOTE: This test cannot be carried out below 32°F (0°C).

Introduction to ACC 2



Inside Air Temperature Sensor Check

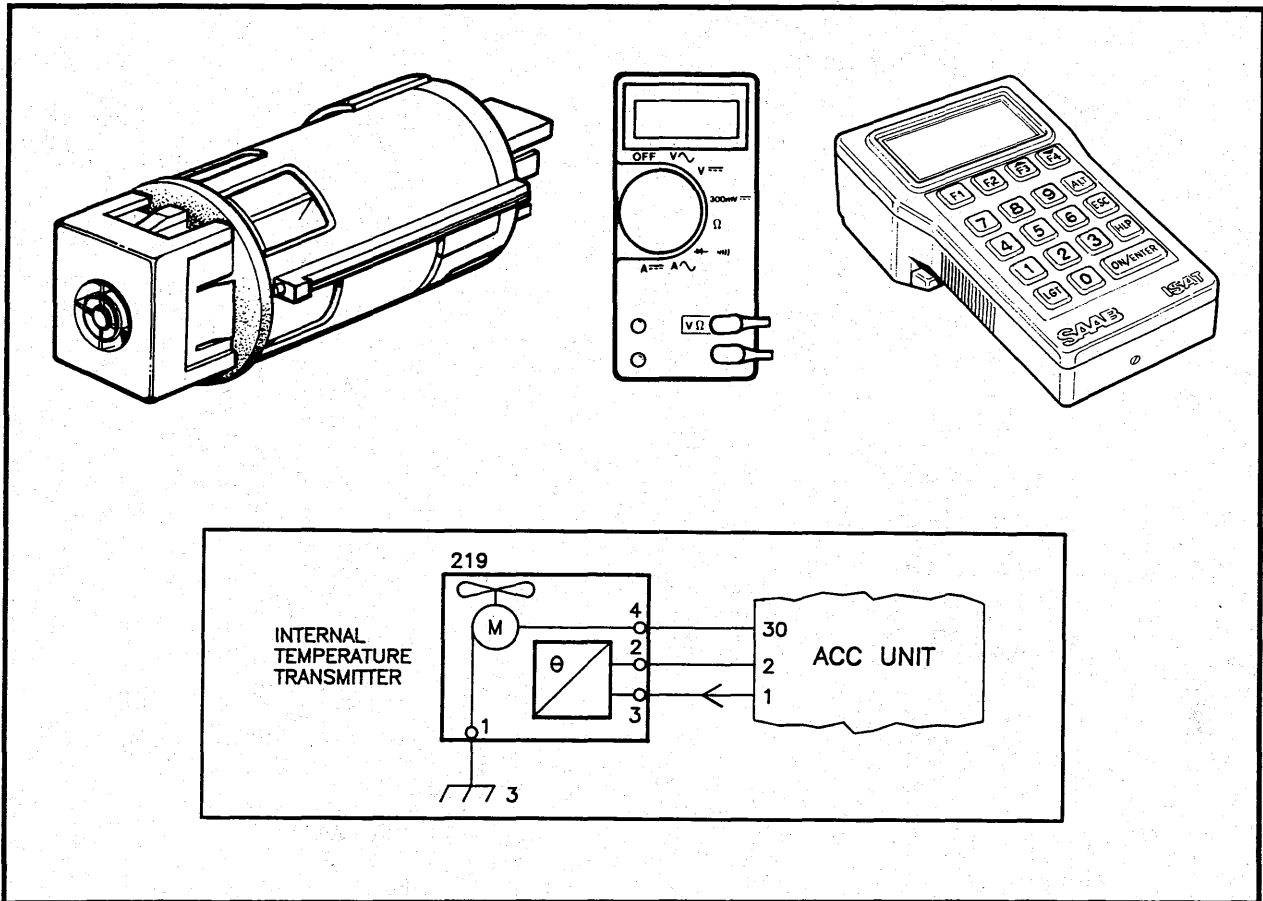

1. Disconnect the ACC unit 39-pin plug and check the resistance value across pins 1 and 2. The value varies between 5 and 35 kohms over the range 0 to +40°C. Values at particular temperatures are:

	Maximum (kohms)	Minimum (kohms)
0°C	30.0	34.8
+10°C	18.5	21.1
+20°C	11.7	13.1
+25°C	9.5	10.5
+30°C	7.6	8.5
+40°C	4.9	5.6

2. If the value is incorrect, disconnect the temperature sensor plug and repeat the resistance check across pins 2 and 3 of the plug. If the value is still incorrect, fit a new temperature sensor.

3. If the value is correct across the temperature sensor plug, check for continuity between the sensor plug and ACC unit 39-pin plug (pins 2 and 2, pins 3 and 1). If the wiring is normal, refit the plugs, clear any fault codes and run the system to determine if a fault is still present.

4. If a fault is still present, measure the voltage at the ACC unit 39-pin plug pin 1. This will vary depending on the sensor resistance value and the battery voltage according to the following formula: (Measure with the ACC plugged in and ignition ON).

$$\frac{(B\text{-volts} - 1.5) \times R\text{-sensor}}{R\text{-sensor} + 10 \text{ kohms}}$$

5. If the voltage is incorrect, try a new ACC unit.

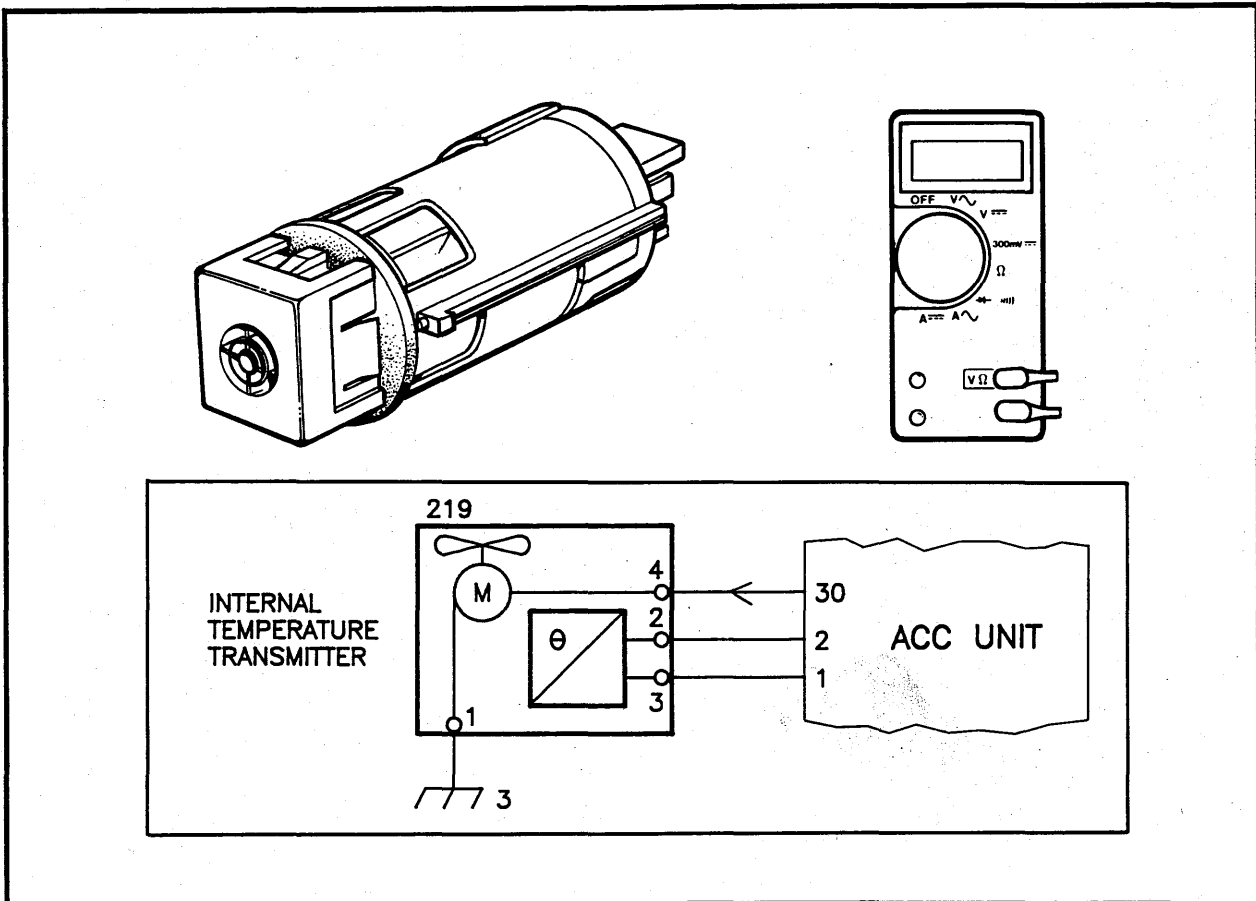

Fault Codes		Fault
Permanent	Intermittent	
53672	33672	Short circuit to earth pin 30 (version 2.01).

1. Disconnect the sensor and check the voltage across pins 4 and 1 of the plug. The reading should be 11 to 12V.
2. If a correct voltage is obtained, refit the plug and check the motor is still stopped before trying a new sensor. Note that the resistance of the fan motor across pins 4 and 1 of the sensor should be approximately 230 ohms.
3. If no voltage is obtained during Step 1, disconnect the 39-pin ACC unit plug and check for continuity between pin 4 of the sensor plug and pin 30 of the ACC unit 39-pin plug. Check also for earth continuity at pin 1 of the sensor plug and that pin 4 of the sensor plug is NOT shorted to earth.
4. If the wiring is normal, refit the plugs and check whether the fan is still stopped before trying a new ACC unit.

Introduction to ACC 2



Common Sensor Ground Fault

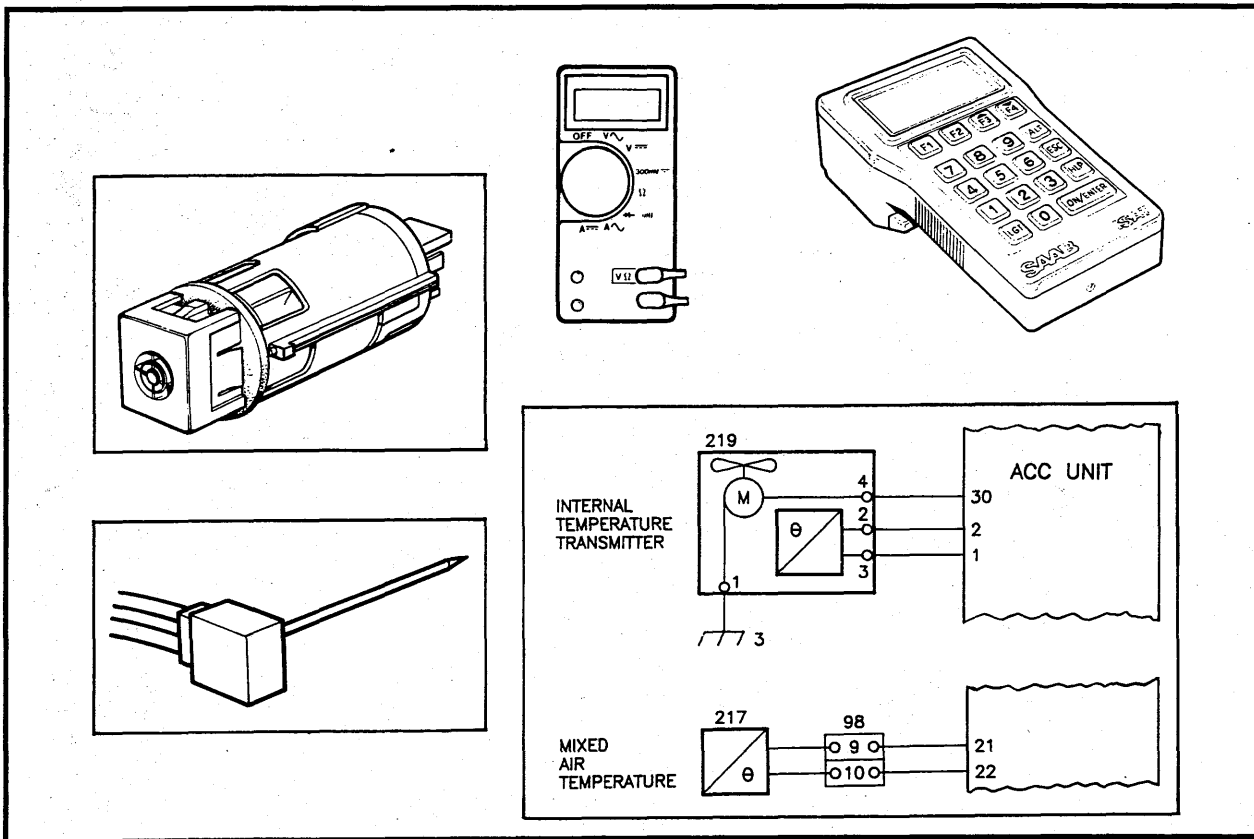

Fault Codes		Fault
Permanent	Intermittent	
42521	22521	These fault codes will all be recorded together when the self-test program detects 12V on the common 0V line for mixed air sensor (pin 22) and the internal temperature sensor (pin 2). *
46322	26322	
46323	26323	

ISAT Command Codes	Display Shows
250	Indoor temperature = +10°C - +40°C.

If Display Shows	Possible Fault
Set temperature on +18°C	: Battery voltage at pin 2 (LED's dim).

ISAT Command Codes	Display Shows
252	Mixed air temperature = 0°C - +80°C.

If Display Shows	Possible Fault
Set temperature of 50°C (version 2.00) or calculated set value by ACC (version 2.01)	: Battery voltage at pin 22 (LED's dim).

* NOTE: Only one fault code (42521/22521) will be recorded if the self-test program detects less than 12V on this common 0V line.

Introduction to ACC 2



Common Sensor Ground Fault

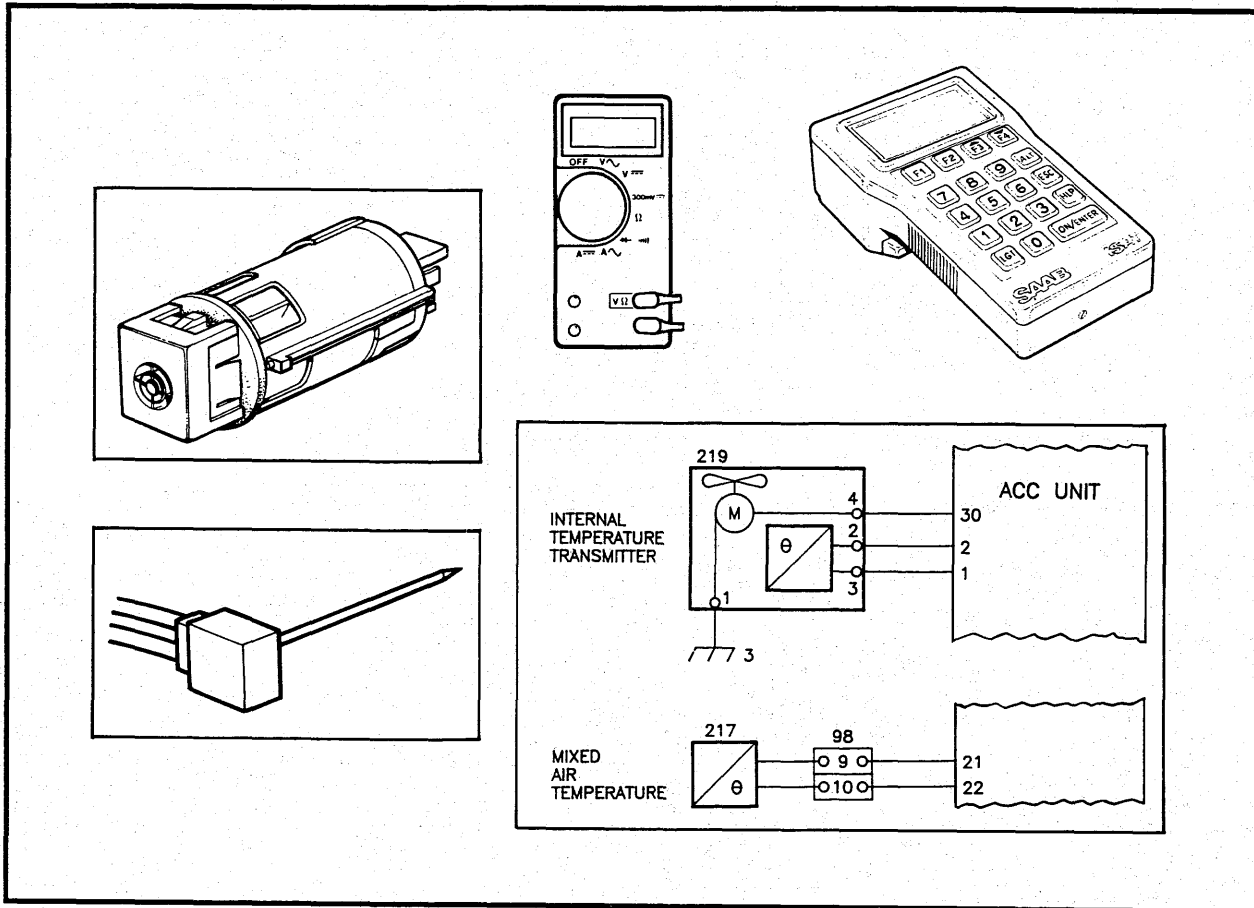

This fault code is recorded when the self test program detects 12V or less on the common 0V line, pin 22 mixed air temperature sensor, and pin 2 inside temperature sensor.

1. With the ignition on measure the voltage of pin 2 or pin 22, and earth, from behind the ACC unit with a 39-pin plug connected.
2. If a voltage is detected switch off the ignition, wait 35 seconds, and disconnect the 39-pin connector from the ACC unit.
3. Switch the ignition on. If a voltage is still detected check the wire to the sensor and the sensor itself.

4. If no voltage is detected refit all the plugs and clear the fault codes. Rerun the system to check that the fault is still present before trying a new ACC unit.

Introduction to ACC 2



Temperature Control Flap Motor Check

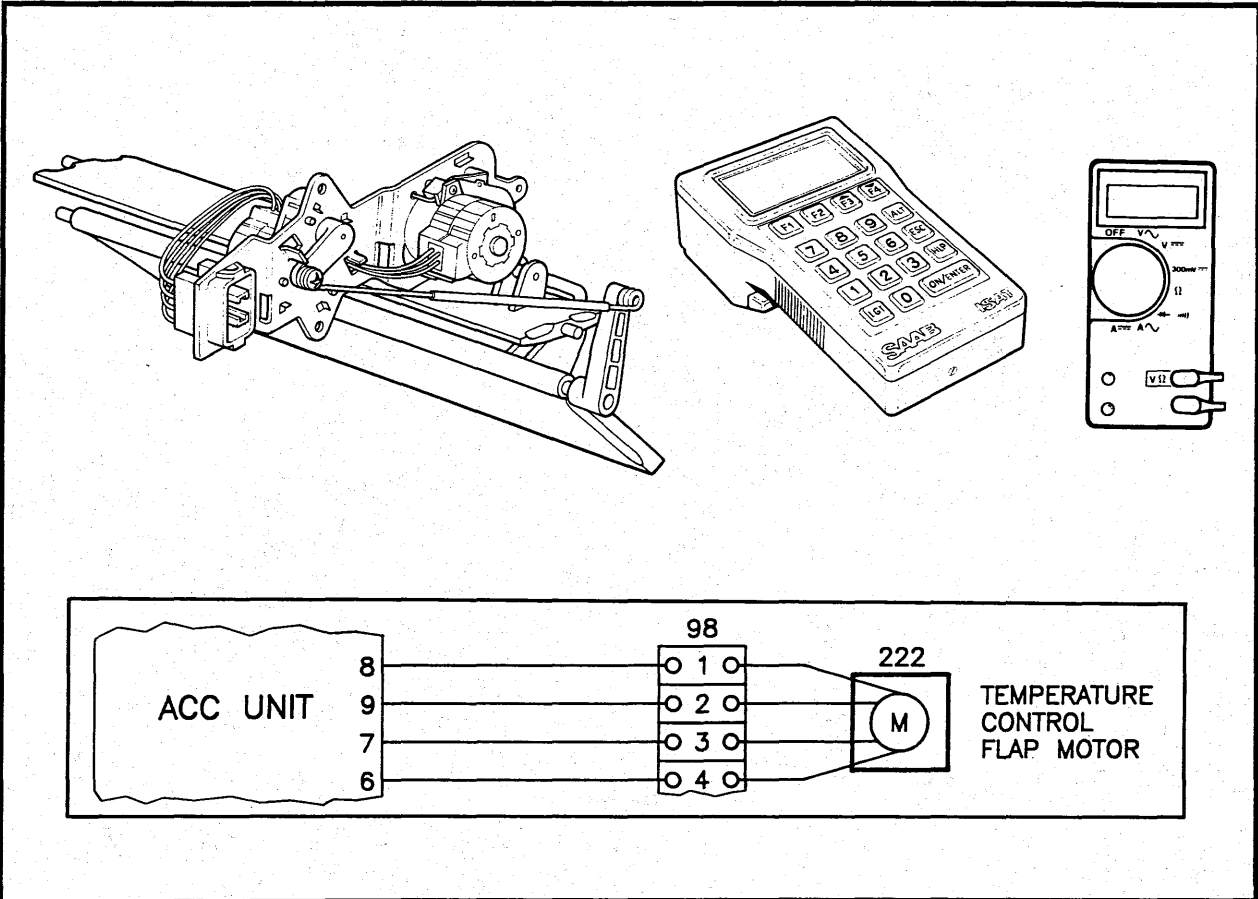

Fault Codes		Fault
Permanent	Intermittent	
53624	33624	Temperature control flap motor overload, open circuit, bridge circuit or internal short circuit in the ACC unit (Version 2.01 will show fault code 53624/33624 along with fault code 53674/33674).
53674	33674	Temperature control flap motor short circuit to earth (version 2.01).

ISAT Command Codes	Display Shows
27A *	Desired position of temperature flap motor. 0% (LO) - 100% (HI).

NOTE: Desired position of temperature flap motor does not mean that the motor is moving to different positions. It is only a request from the ACC unit. Use the TEMP SET buttons to change the flap position and visually verify flap movement.

* To enter command code 27A, press "2," "7" then "F1."

Introduction to ACC 2

SAAB

Temperature Control Flap Motor Check

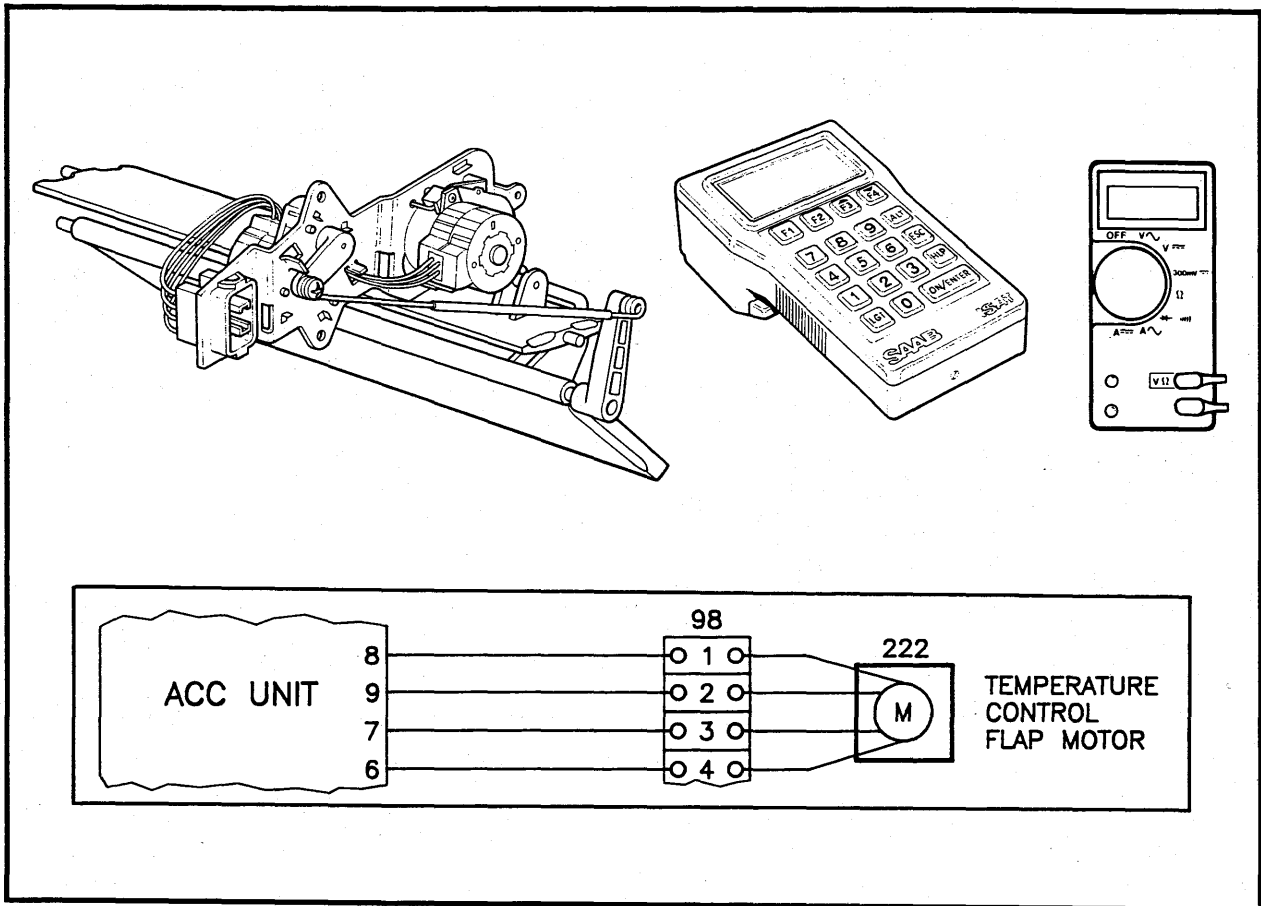

1. Visually check that the motor is moving the temperature control flap, using the temperature select pushbuttons to alternately select HI and LO.
2. If the flap is not operating, disconnect the ACC unit 39-pin plug and check the resistance of the stepping motor windings across pins 6 & 7 and 8 & 9. The value should be approximately 100 ohms at 20°C.
3. If the resistance is incorrect, disconnect the stepping motor plug and check the resistance values directly across the motor windings. If these are incorrect try a new stepping motor.
4. If the stepping motor winding resistances are correct, check for continuity between the ACC unit plug and the stepping motor plug, 98. Check also for short circuits between the wires and to earth.
5. If all electrical measurements are normal, refit the plugs. Clear the fault codes and run the system to check that the fault is still present before trying a new stepping motor.
6. If fitting a new stepping motor fails to clear the fault, refit the old stepping motor unit and try a new ACC unit.

Introduction to ACC 2



Distribution Flap Motor Check

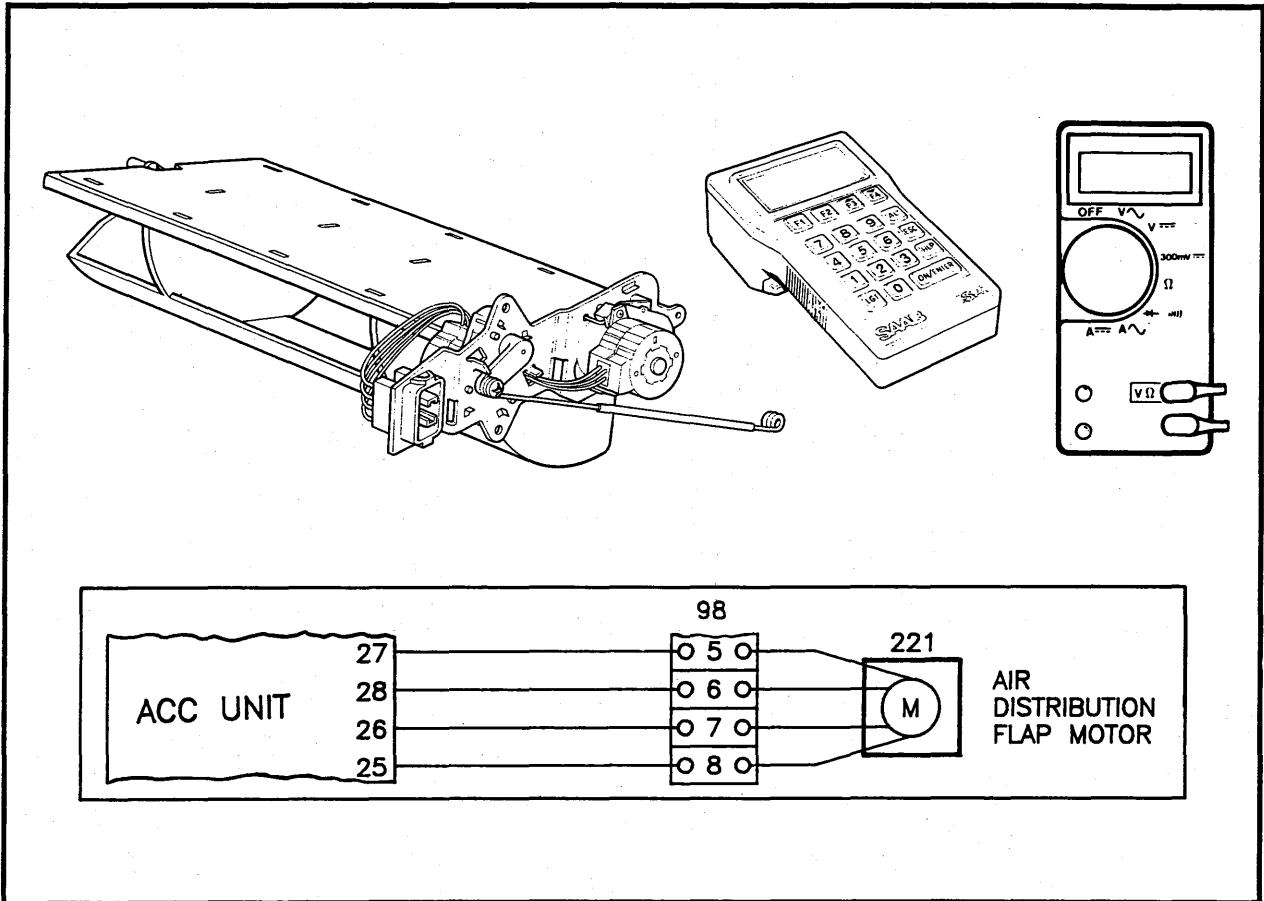

Fault Codes		Fault
Permanent	Intermittent	
53623	33623	Air distribution flap motor overload, open circuit, bridge circuit or internal short circuit in the ACC unit (Version 2.01 will show fault code 53623/33623 along with fault code 53673/33673).
53673	33673	Air distribution flap motor, short circuit to earth (version 2.01).

ISAT Command Codes	Display Shows
27B *	Desired position of distribution flap motor. 45°C (vent) - 135°C (def).
NOTE: Desired position of distribution flap motor does not mean that the motor is moving to different positions. It is only a request from the ACC unit. Use the ACC air distribution buttons to change the flap position and visually verify flap movement.	

* To enter command code 27B, press "2," "7" then "F2."

Distribution Flap Motor Check

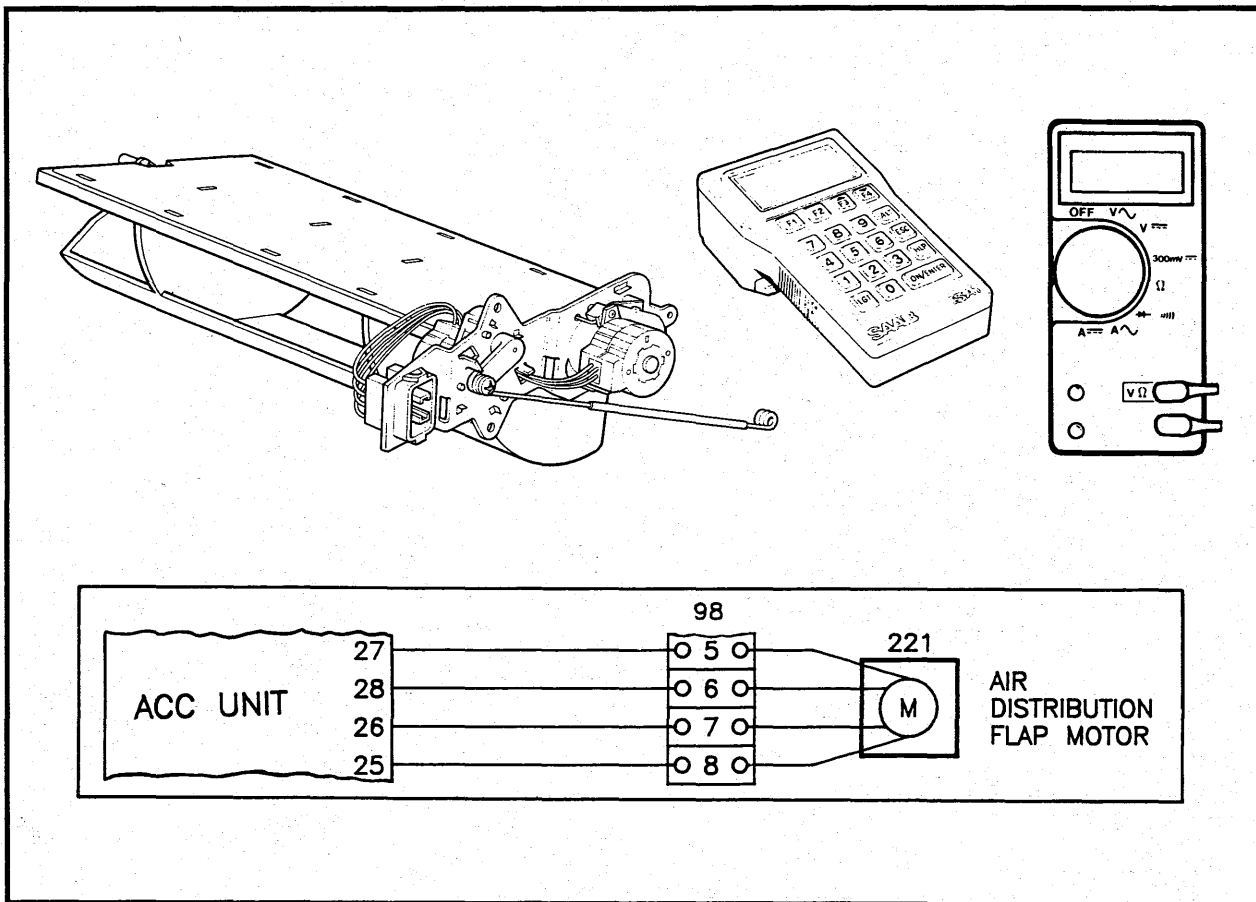

1. Visually check that the air distribution flap is working by selecting DEF and VENT to move the flap over the complete range of movement.
2. If the flap is not operating, disconnect the ACC unit 39-pin plug and check the resistance of the motor windings across pins 25 & 26 and 27 & 28. The value should be approximately 100 ohms at 20°C.
3. If the resistance is incorrect, disconnect the stepping motor plug, 98, and check the resistance values directly across the motor windings. If these are incorrect try a new stepping motor.
4. If the stepping motor winding resistances are correct, check for continuity between the ACC unit plug and the stepping motor plug. Check also for short circuits between the wires and to earth.
5. If all electrical measurements are normal refit the plugs. Clear the fault codes and run the system to check that the fault is still present before trying a new stepping motor.
6. If fitting a new stepping motor fails to clear the fault, refit the old stepping motor unit and try a new ACC unit.

Introduction to ACC 2



Recirculation Flap Motor Check

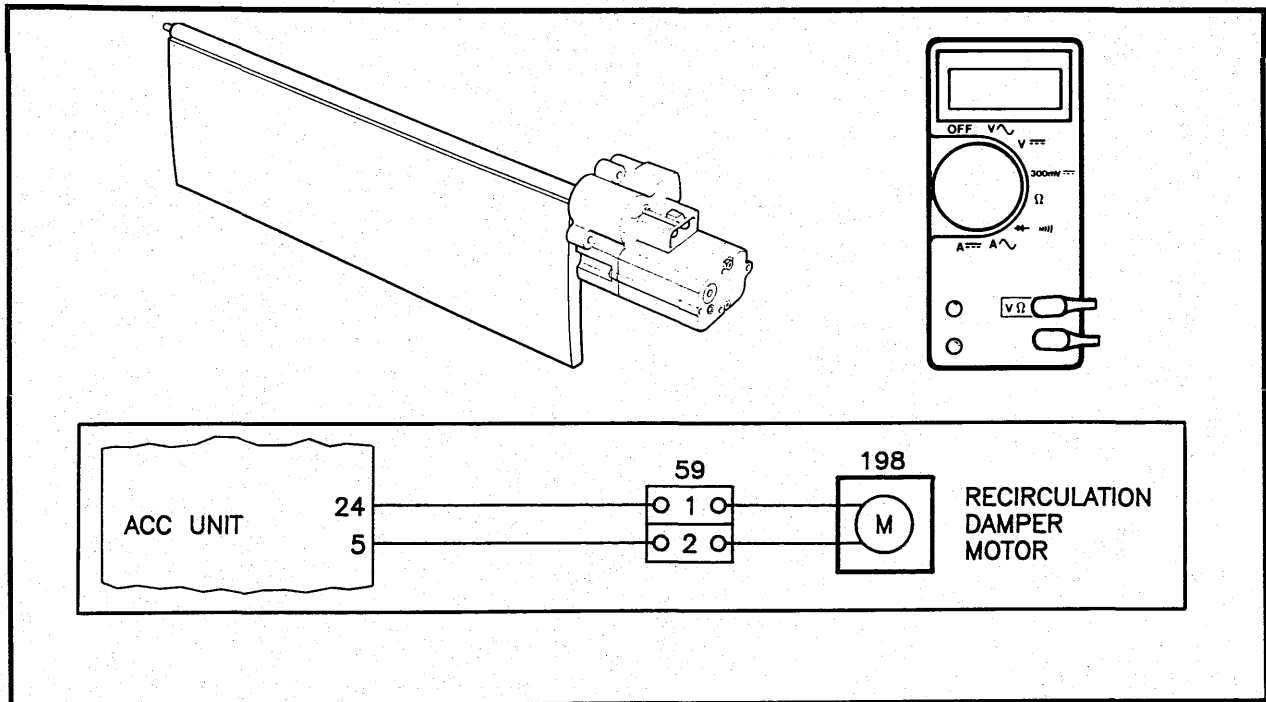

Fault Codes		Fault
Permanent	Intermittent	
53621	33621	Recirculation flap motor short circuit +12V. } (Version 2.01) Short circuit to earth.
53671	33671	

ISAT Command Codes	Display Shows
279	Desired position of recirculation flap motor. Fresh air or recirculation.

NOTE: Desired position of recirculation motor does not mean that the motor is moving to different positions. It is only a request from the ACC unit. Use the ACC recirculation button to change the flap position and visually verify flap movement.

1. Visually check if the flap is moving between the recirculation and fresh air positions when the flap is controlled manually.
2. Disconnect the ACC unit 39-pin plug and check the resistance of the motor windings across the plug pins 5 & 24. The value should be approximately 50 ohms.
3. If the resistance is incorrect, disconnect the motor plug and check the resistance value directly across the motor windings. If this is incorrect try a new motor.
4. If the motor winding resistance is correct, check for continuity between the ACC unit plug and the motor plug. Check also for short circuits between the wires and to earth.
5. If all electrical measurements are normal connect the 39 pin plug on the ACC and measure the voltage on plug 59, pins 1 and 2. Connect the Red cable from the multi-meter on pin 1, and the Black cable on pin 2. The reading should be taken when the flap is moving to re-circulation (+10/12V) and the LED is illuminated or is moving to fresh air (-10/12V) and the LED is extinguished. If you get a correct reading try a new motor.
6. If not, try a new ACC unit.

Ventilation Fan Check

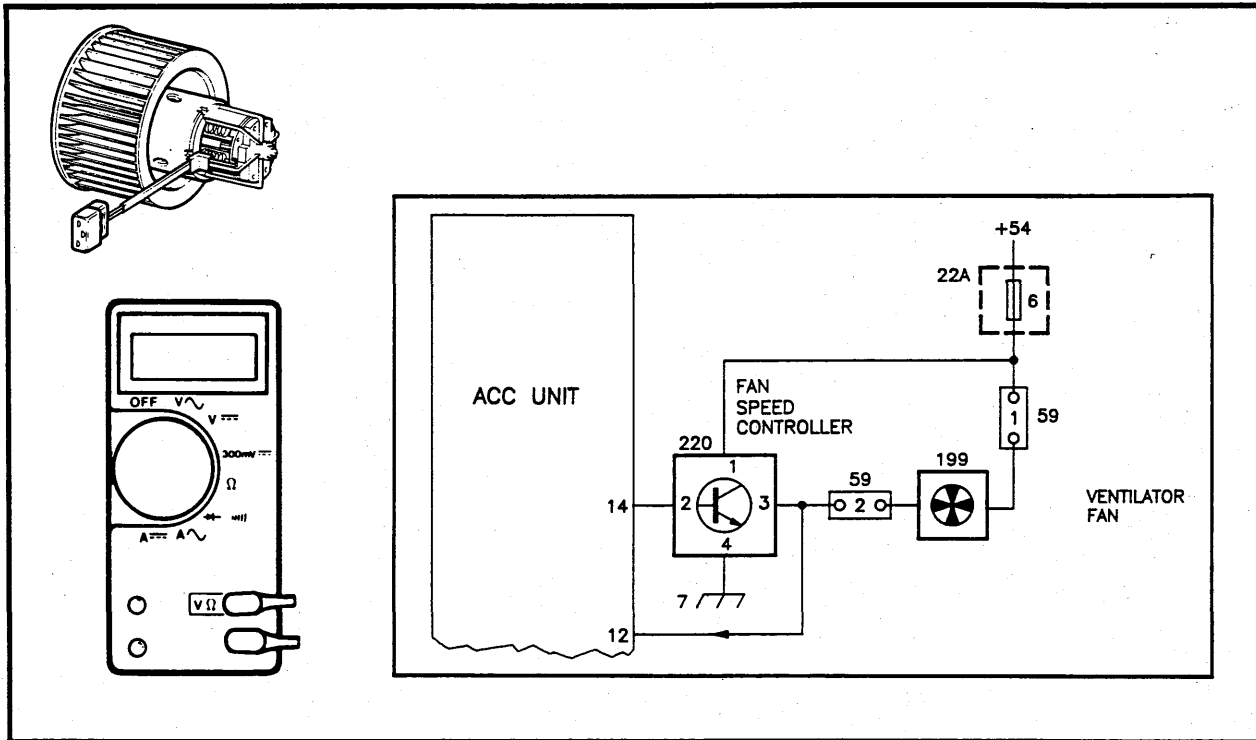

ISAT Command Codes	Display Shows
22A **	Ventilation fan control signal, 0 - 5V.

CAUTION: THE FAN SPEED CONTROLLER HEAT SINK IS LIVE (1.5 TO 12V DEPENDING ON THE SPEED OF THE MOTOR), DO NOT CONNECT THE HEAT SINK TO EARTH.

If the ventilation fan does not work, or the ACC cannot control the speed, carry out the following:

1. Check the ventilation fan fuse.
2. Check the ventilation fan control signal at the ACC unit (pin 14 and earth). Vary the speed using the manual fan buttons to

change the level of the signal.

3. If control voltage measurement is incorrect, try a new ACC unit.
4. If the fan speed control signal is normal, disconnect the ACC unit 39-pin plug and check for continuity between pin 14 of the plug and pin 2 of the speed controller.
5. If the connection between the ACC unit and the fan speed controller is normal, check the supply voltage to pin 1 of the fan speed controller and the earth connection pin 4.

Signal levels

Signal Measured	ACC Pins	Operation *	Voltage
Ventilation fan control	14 & earth	Min to max speed	0 to 5V
Speed check	12 & earth	Min to max speed	12 to 1V

* Change the fan speed using the buttons on the ACC unit.

** To enter command code 22A, press "2," "2" then "F1."

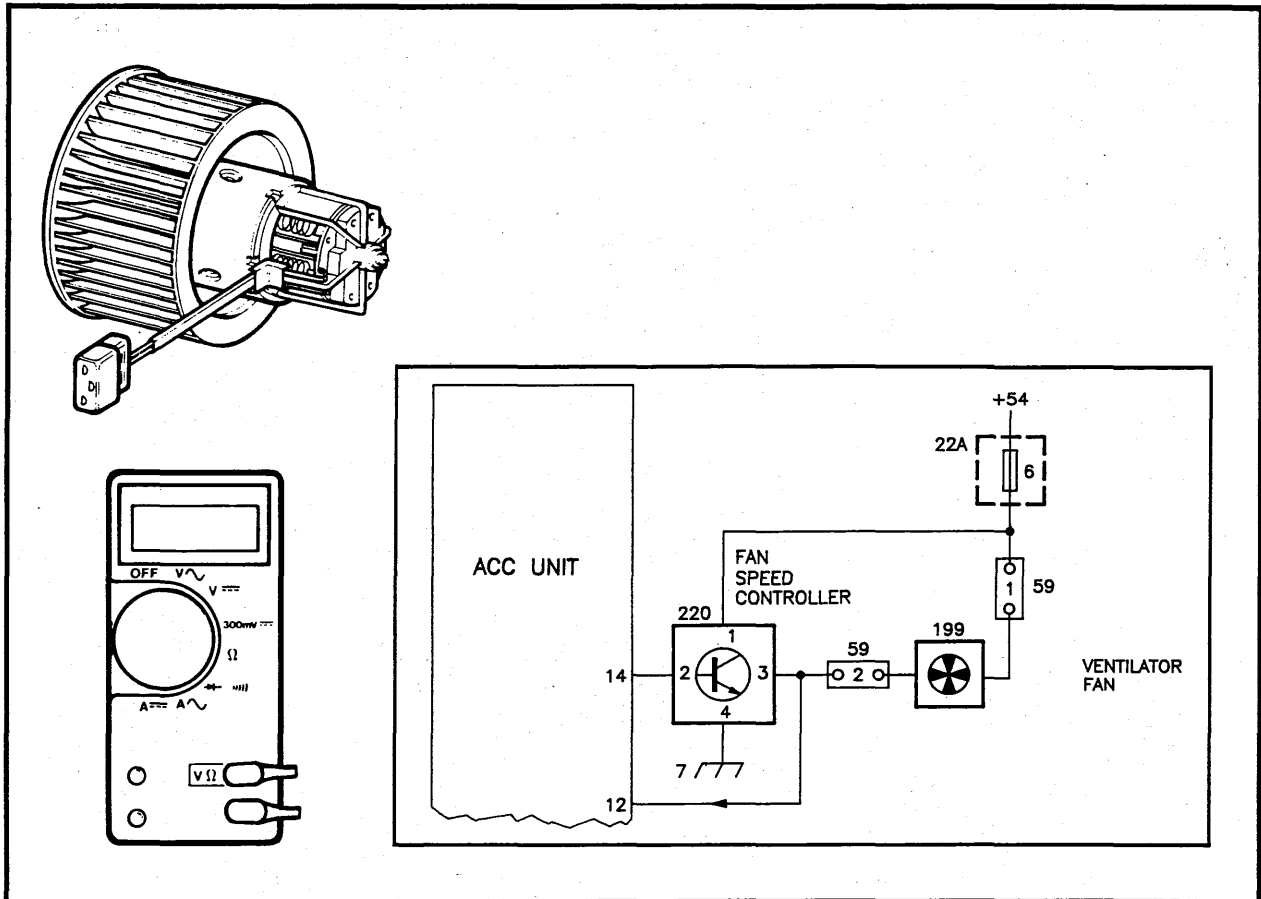

6. If the supply and earth connections are normal, short circuit pins 3 and 4 of the speed control unit plug with the unit disconnected. If the motor now runs the fault may be in the fan speed controller. However, refit all plugs and run the system to check if the fault is still present before trying a new fan speed controller.
7. If the motor fails to run with the fan speed control unit shorted out. Switch the ignition off and wait for 35 seconds. Disconnect the ACC unit 39-pin plug and
 8. If the value to plug 59 is correct, the fault may be in the motor. However, refit all plugs and run the system to check if the fault is still present before trying a new motor.

Rear Door Fans Check

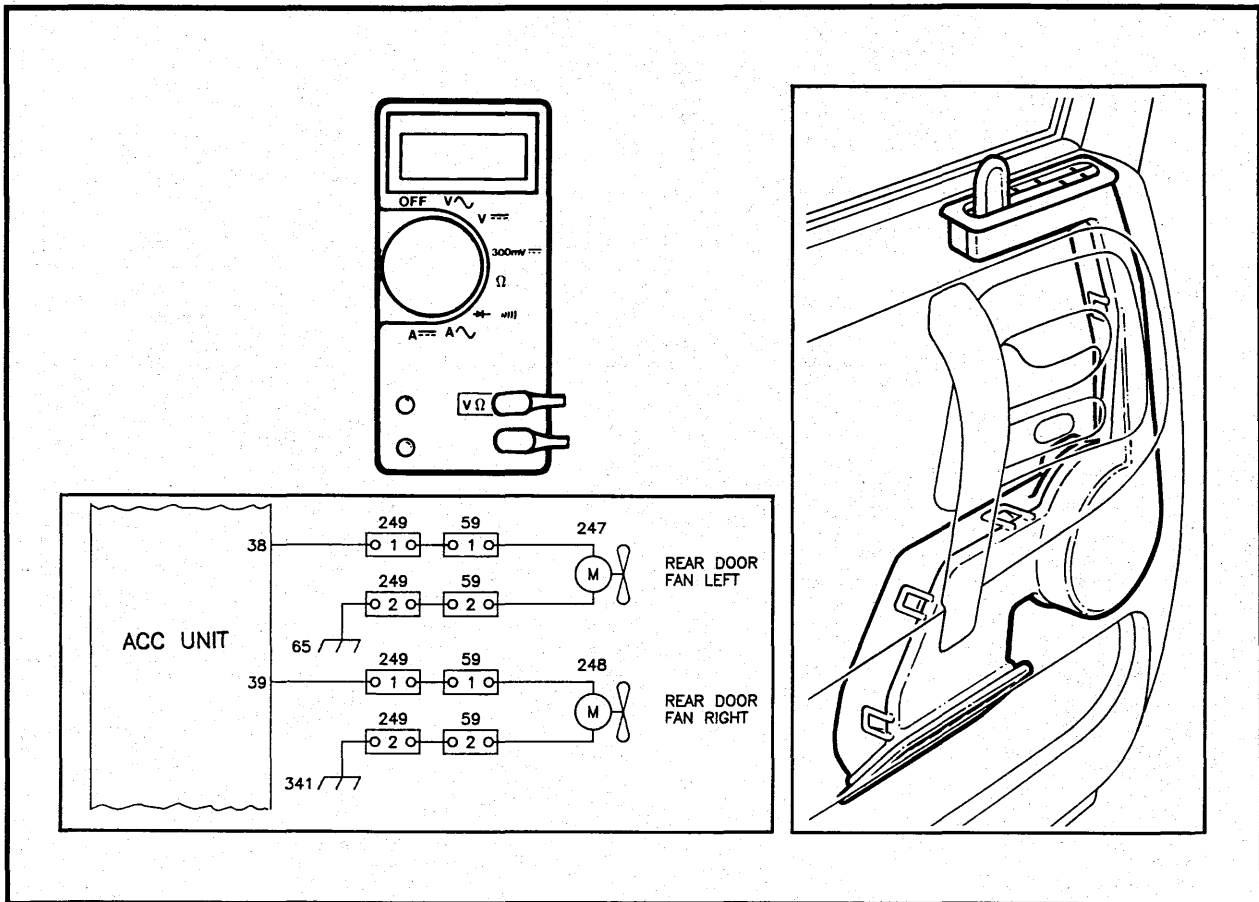

1. Check the fan output signal at pin 38 or 39 on the ACC unit, varying the speed manually by using the ventilation fan speed controls.
2. If the output signal is correct, disconnect the ACC unit 39-pin plug and check the resistance of the door fan windings. The value should be <80 ohms. If the resistance is correct, refit the plugs and run the system to check if the fault is still present.
3. If the motor resistance is incorrect, check the wiring between the motor and ACC unit 39-pin plugs, and if this is normal try a new motor.
4. If the fan output signal is incorrect thoroughly check the 39-pin plug connections before trying a new ACC unit.

Signal levels

Signal Measured	ACC Pins	Operation *	Voltage
Rear door fan left	38 & earth	Min to max speed Fan turned off	7 to 11V 0V
Rear door fan right	39 & earth	Min to max speed Fan turned off	7 to 11V 0V

* Change the rear door fan speed using the cabin fan speed buttons on the ACC unit.

Introduction to ACC 2



Rear Window And Outside Mirror Heaters Check

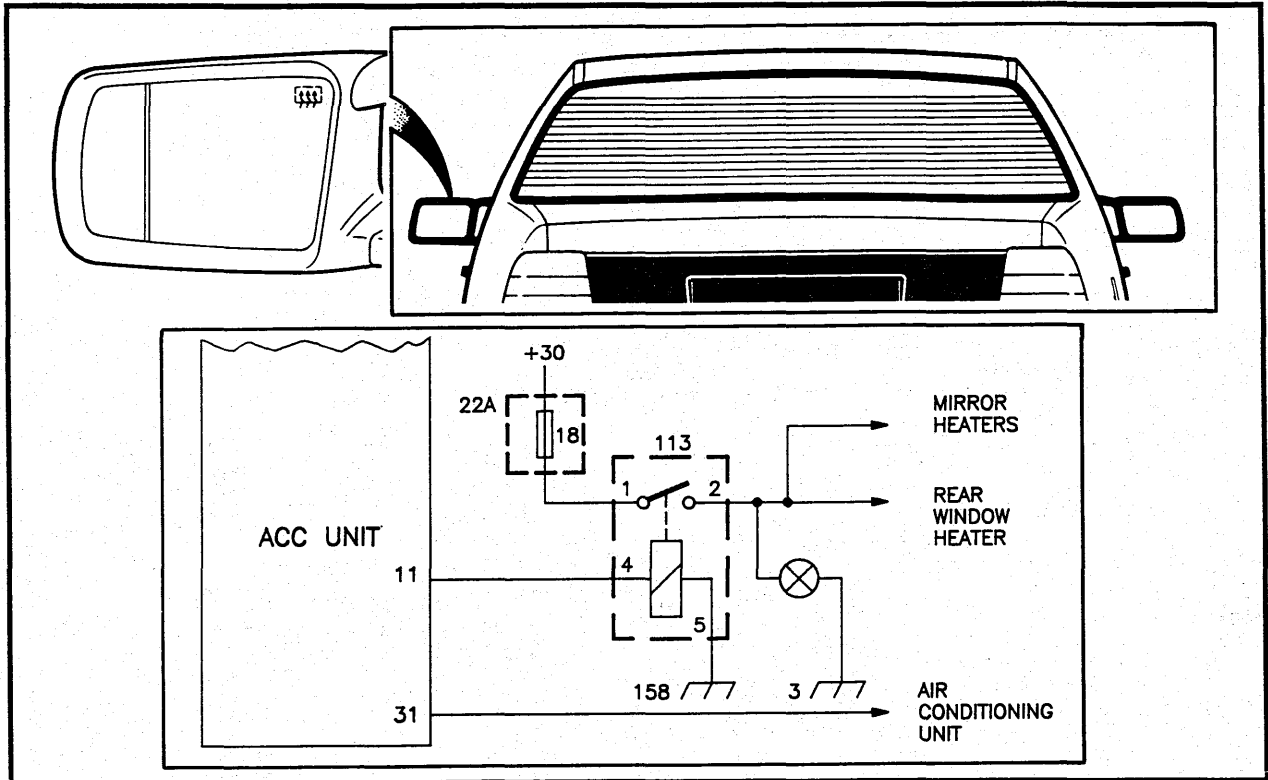

Fault Codes		Fault (Version 2.01 only)
Permanent	Intermittent	
53221	33221	Control signal rear demister relay Open circuit or short circuit to 12V (pin 11) with the rear demister off. } Version 2.01 Short circuit to earth (pin 11) with the rear demister on. }
53271	33271	
53222	33222	Control signal to AC relay or fuel Injection control unit Open circuit or short circuit to 12V (pin 31) only with ECON on. } Version 2.01 Short circuit to earth (pin 31) only with AUTO on. }
53272	33272	

1. Check the supply fuse (to the rear demister).
2. Check if a supply is obtained at the window heater when the supply is switched on manually.
3. If no supply is being obtained at the heater,

4. check the rear heater signal at the ACC unit.
4. If the signal is correct the fault is in the relay unit or the associated wiring.
5. If the control signal from the ACC unit is incorrect, thoroughly check the ACC unit plug connections before trying a new ACC unit.

Signal levels

Signal Measured	ACC Pins	Operation	Voltage
Rear heater etc.	11 & Earth	On	12V
		Off	0V
AC	31 & Earth	Auto On	12V
		ECON	0V

Introduction to ACC 2

Air Conditioning Unit Wiring Diagram

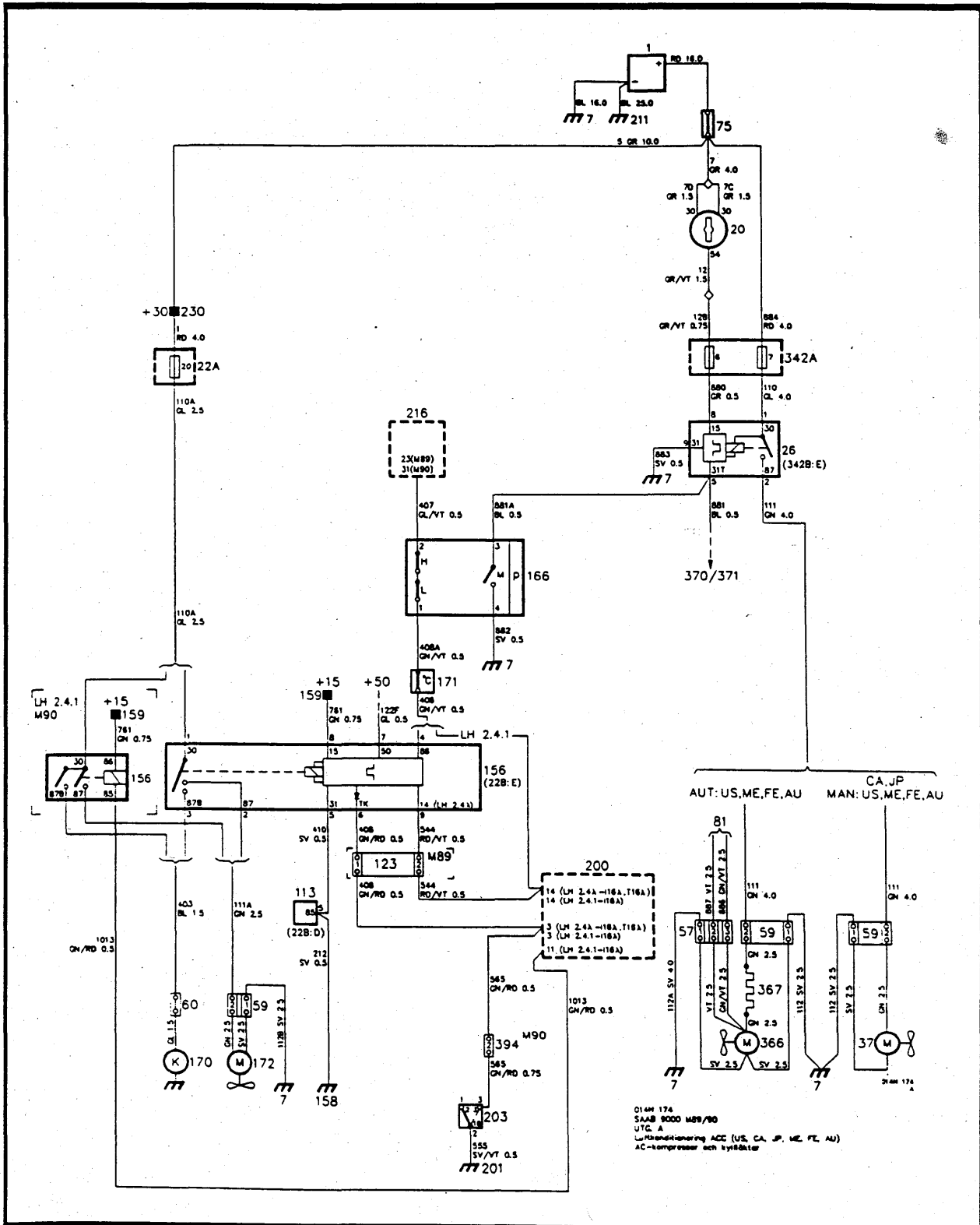



SAAB

Saab-Scania of America, Inc., Saab Drive,
P.O. Box 697, Orange, CT 06477

© COPYRIGHT 1989 By Saab-Scania of America, Inc.
Modification Rights Reserved. P/N 02 14 395