

Saab 9000

Service Manual

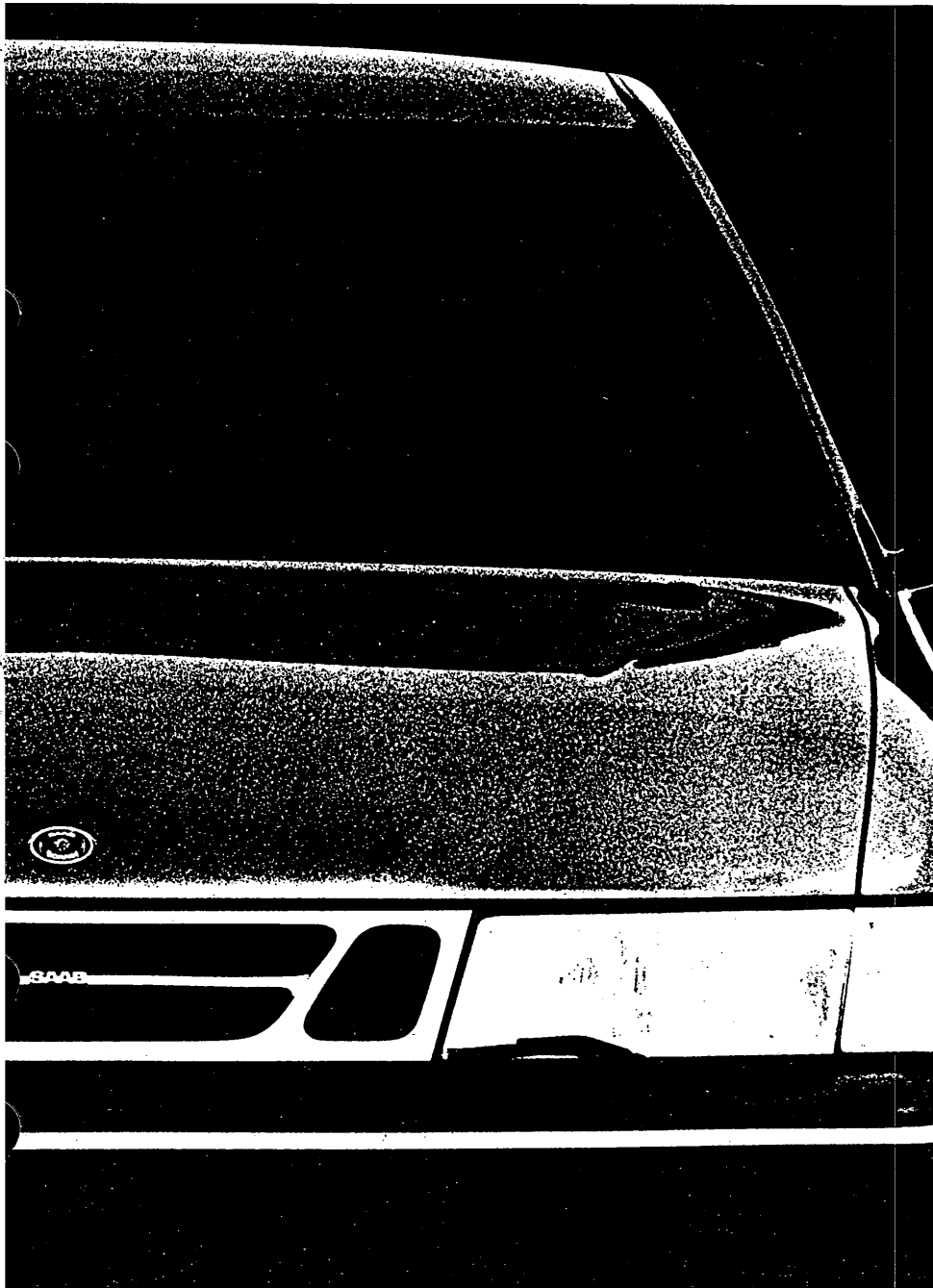

M 1997

ENG

0 News

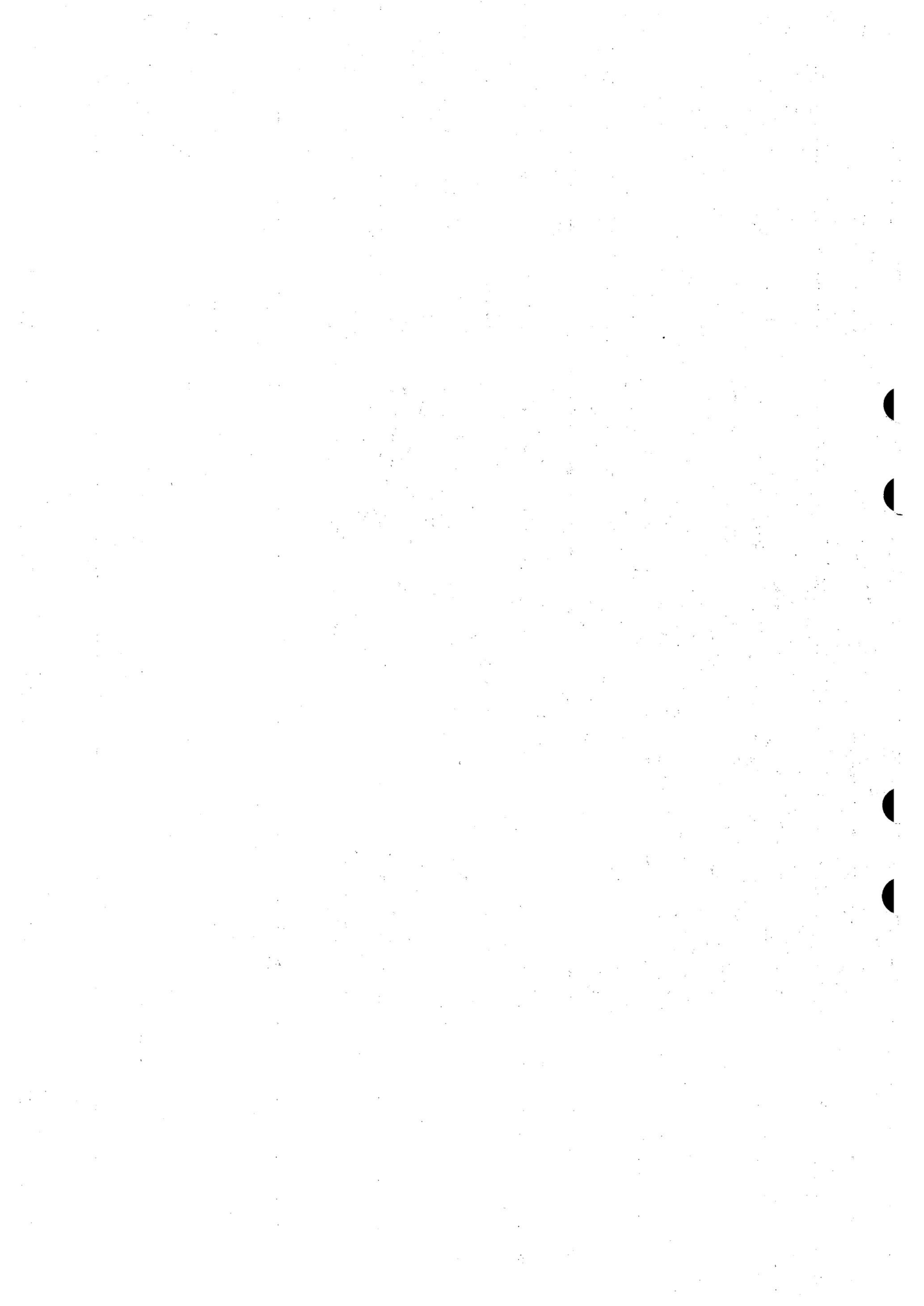

Warning, Important and Note

The headings "Warning", "Important" and "Note" occur from time to time in the Service Manual. They are used to draw the attention of the reader to information of special interest and seriousness. The importance of the information is indicated by the three different headings and the difference between them is explained below.



WARNING

Warns of the risk of material damage and grave injury to mechanics and the driver, as well as serious damage to the car.

Important

Points out the risk of minor damage to the car and also warns the mechanic of difficulties and time-wasting mistakes.

Note

Hints and tips on how the work can be done in a way that saves time and labour. This information is not provided for reasons of safety.

Market codes

The codes refer to market specifications

AT	Austria	GB	Great Britain
AU	Australia	GR	Greece
BE	Belgium	IS	Iceland
CA	Canada	IT	Italy
CH	Switzerland	JP	Japan
DE	Germany	ME	Middle East
DK	Denmark	NL	Netherlands
ES	Spain	NO	Norway
EU	Europe	PA	Asia/Pacific region
FE	Far East	SE	Sweden
FI	Finland	US	USA
FR	France	UC	US California

General

Jubilee car – 50 years – 1997

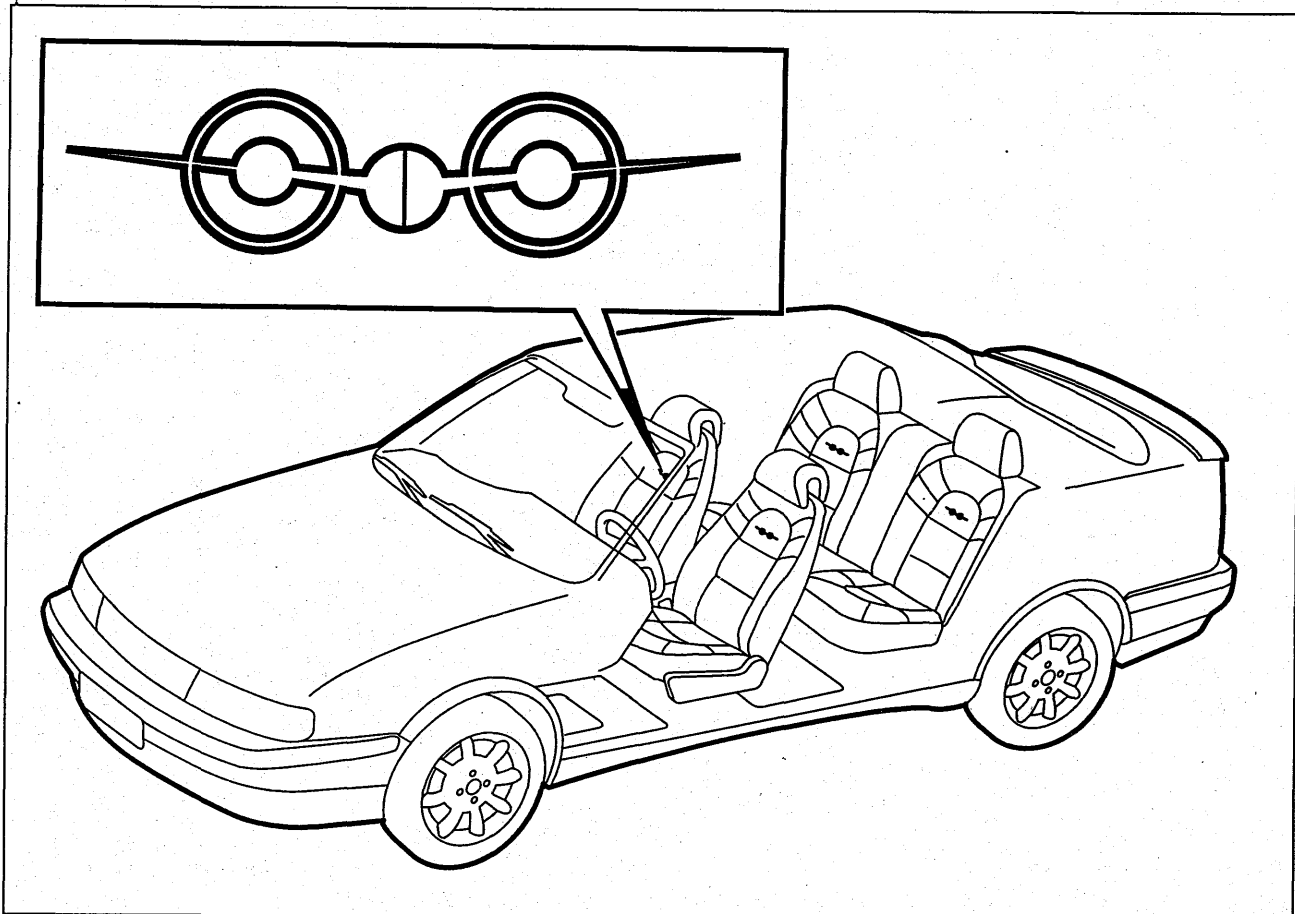

The jubilee car is an M1997 Saab 9000 CSE equipped with:

Engine choice:

- 2.0 LPT
- 2.3 LPT
- 2.3 T

Interior:

- Jubilee logotype printed on outer edge of front and rear seat backrests.
- Specially designed leather upholstery:
 - Black with suede insertions or
 - Sand Beige with suede insertions.
- Wood- and leather steering wheel
- Leather gear-lever knob and gaiter
- Special textile carpets of exclusive design and colour (option).

Wheels:

- New Silver Spoke 6" X 15", enamelled silver.
- Super Aero 6.5" X 16", enamelled silver, with Aero dampers and springs.

Chassis:

- Aero dampers and springs for Super Aero wheels.

Exterior:

- Aero-styling

Body colour choice:

- Embassy Blue
- Silver
- Black
- Amethyst Violet

Technical data

Engine number

Points which have been changed since last year:

Pos. 6 Exhaust emission control specification has been changed from a description of the emission control system to specifying the car model for which it is designed.

Pos. 10 The model year designation for 1997 is V.

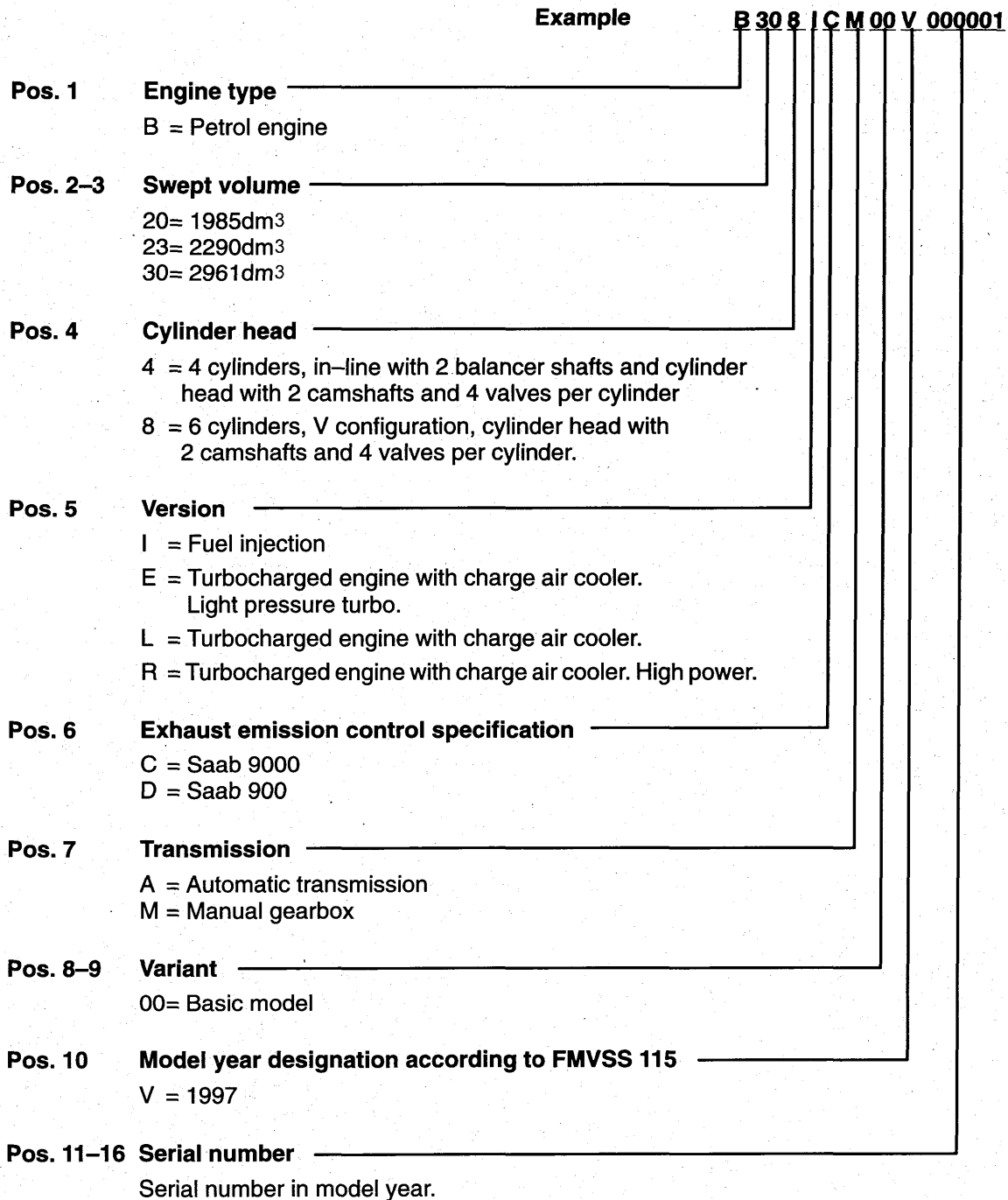

Service

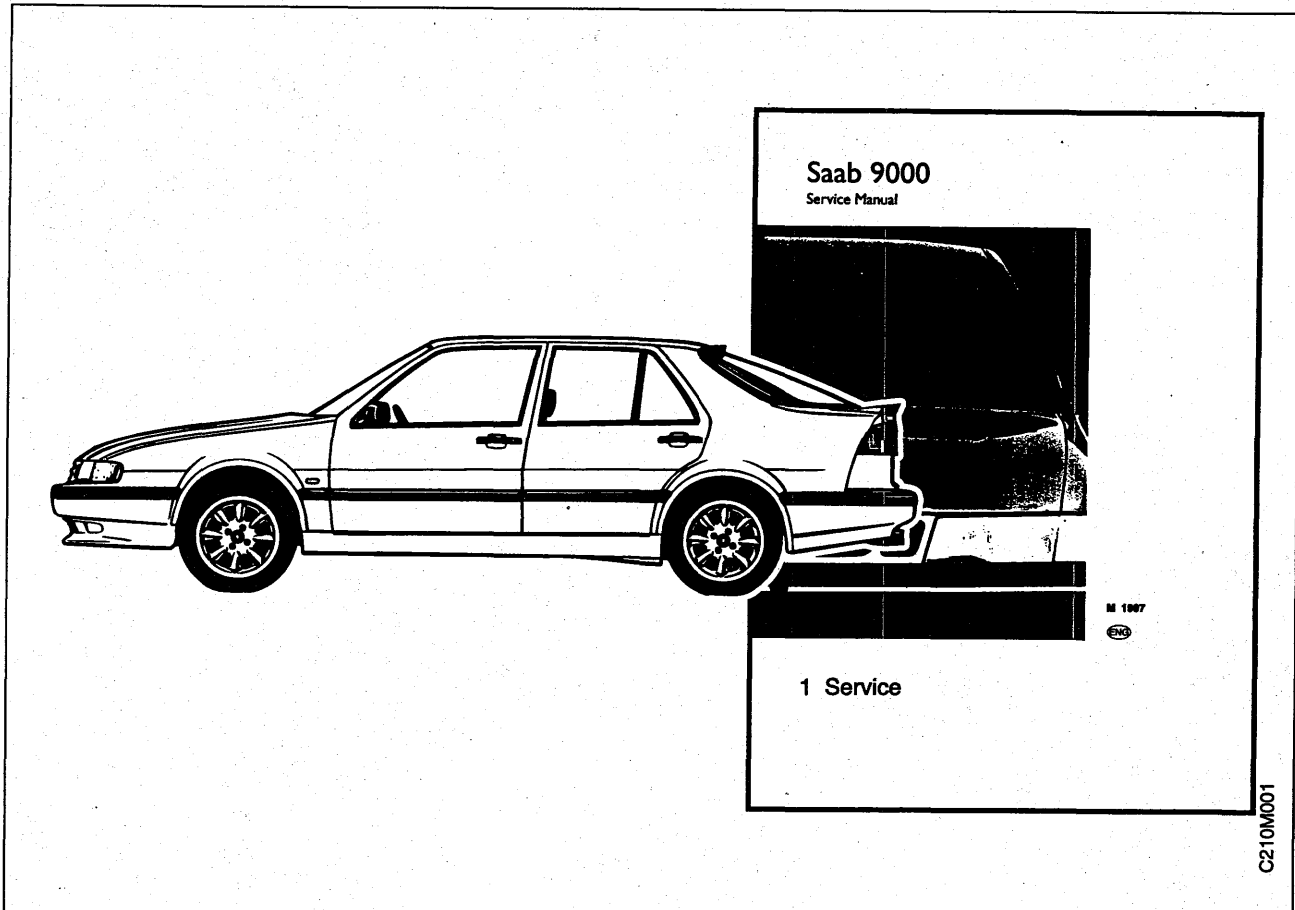

Service Manual 1 "Service" has been revised and now applies to M1994, M1995, M1996 and M1997 Saab 9000 cars.

Points which have been changed since last year include:

- service interval for timing belt, V6, M97.
As a result of the belt having been changed for a new type, the service interval has been extended from 50000 km to 90000 km.

Engine

Exhaust system for 2.0i	7	Motronic/Trionic engine management systems	8
Timing belt V6-engines	7		

Exhaust system for 2.0i

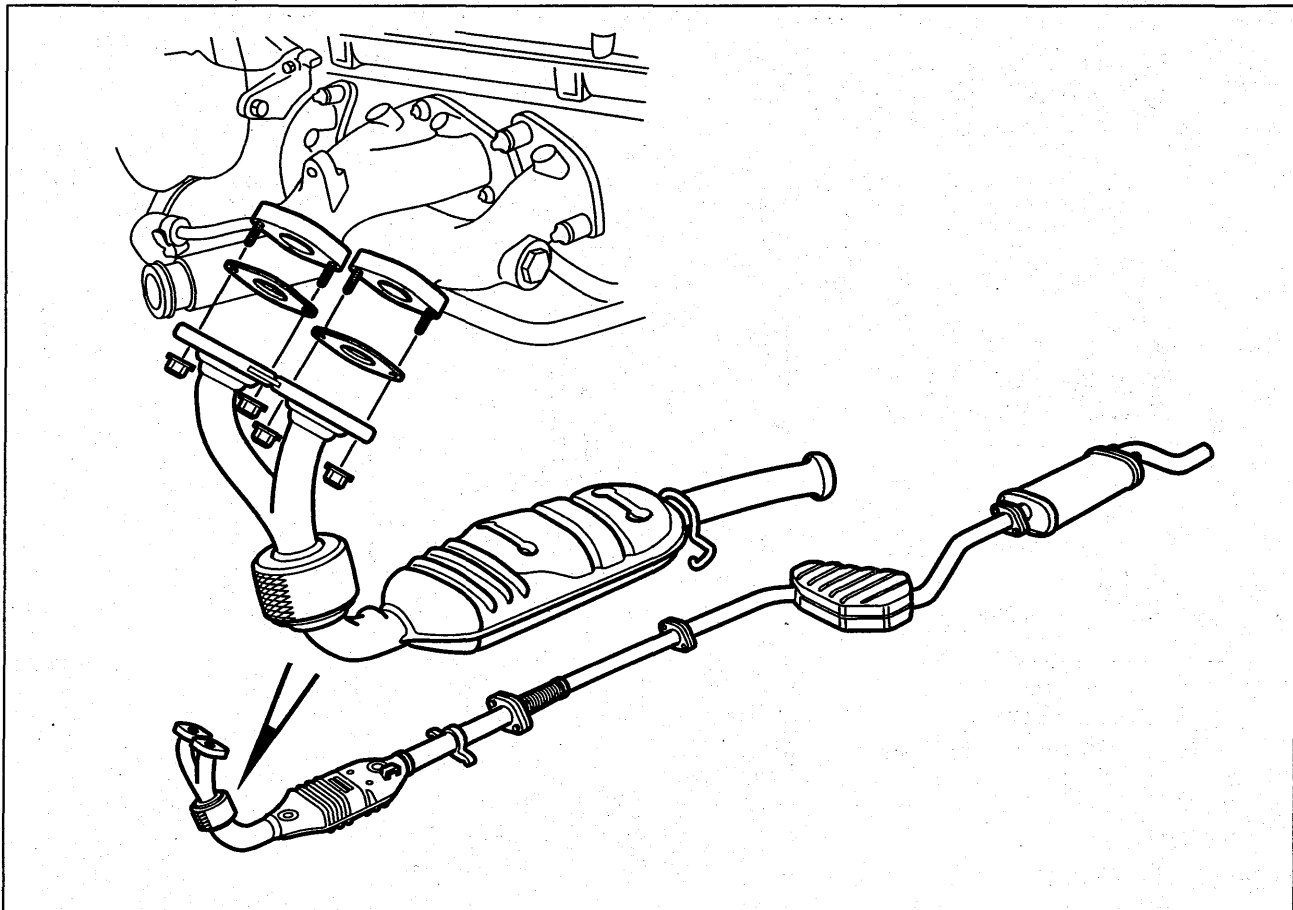

To improve exhaust emission control and reduce external noise, the 2.0i engine is now fitted with the same exhaust system as the 2.3i engine. As a result of the engine's improved emission control it is now rated as environmental class C2 instead of C3 and the external noise is now below 74 dB, which is the new European legal requirement.

Timing belt, V6-engines

On all M97 V6 engines the timing belt has been changed for one having a longer service interval. Since the belt tensioner and timing cover are adapted to the new belt, it cannot be fitted on earlier models.

Motronic/Trionic engine management systems

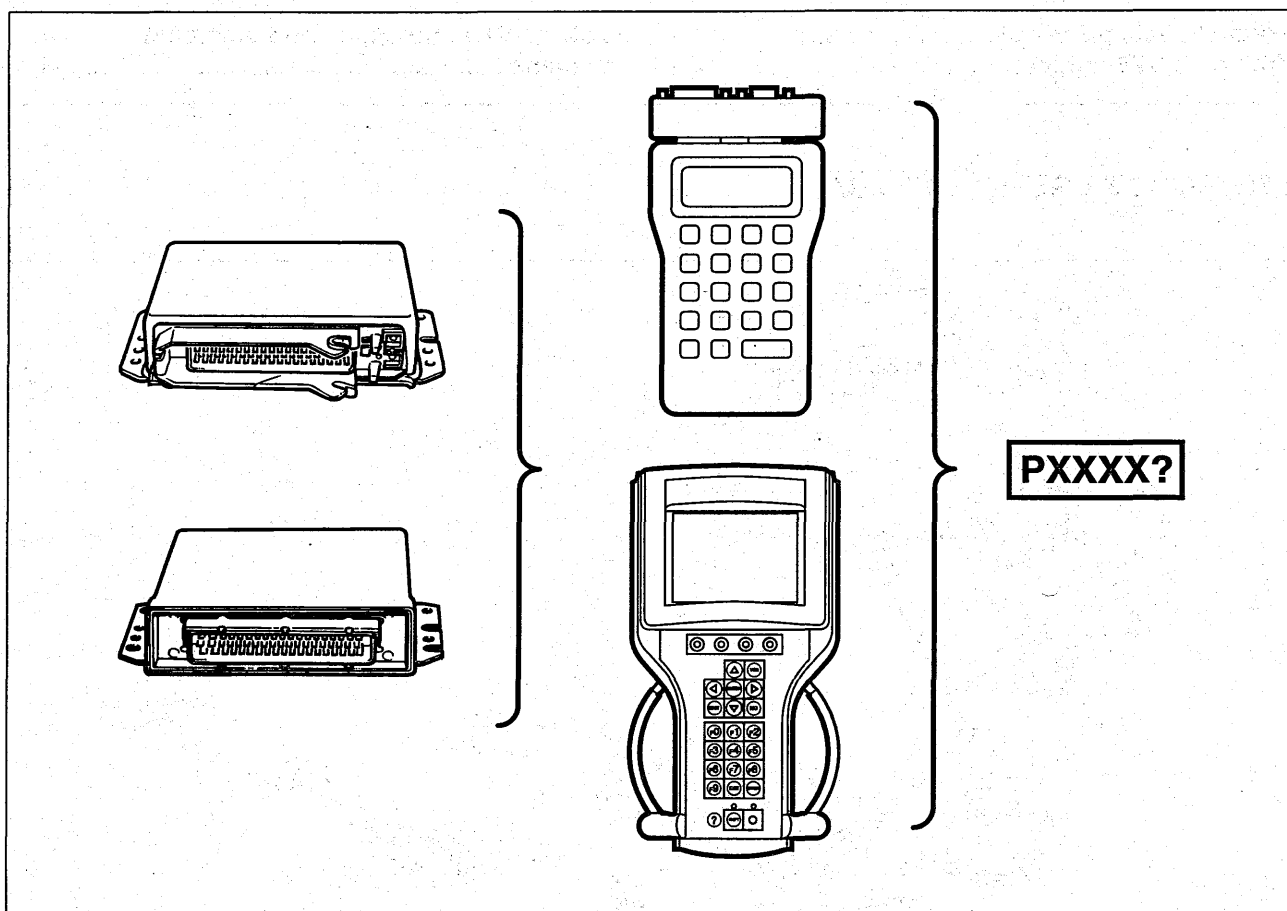

Diagnostic trouble codes for the Motronic/Trionic OBD II engine management systems have been changed with effect from M97. A number of DTCs have been added or augmented and some have been discontinued.

However, since the ISAT scan tool will not be updated for M97, diagnostic trouble code readings can be obtained only with Tech 2.

The "new" diagnostic trouble codes for M97 were still in preparation at the time of going to press and will therefore be presented in a separate Service Manual "2:7 OBD II, Supplement M96-M97".

The manual will also include the diagnostic trouble codes which for some reason were not included in the manuals for M96 and also those introduced at the turn of the year 96/97.

Electrical system

Brake lights switch	9	Rear fog light, wiring diagram for other mar-	
Rear fog light	10	kets	12
Rear fog light, US/CA wiring diagram	11	Relay table, main fuse box, glove box	13

Brake lights switch

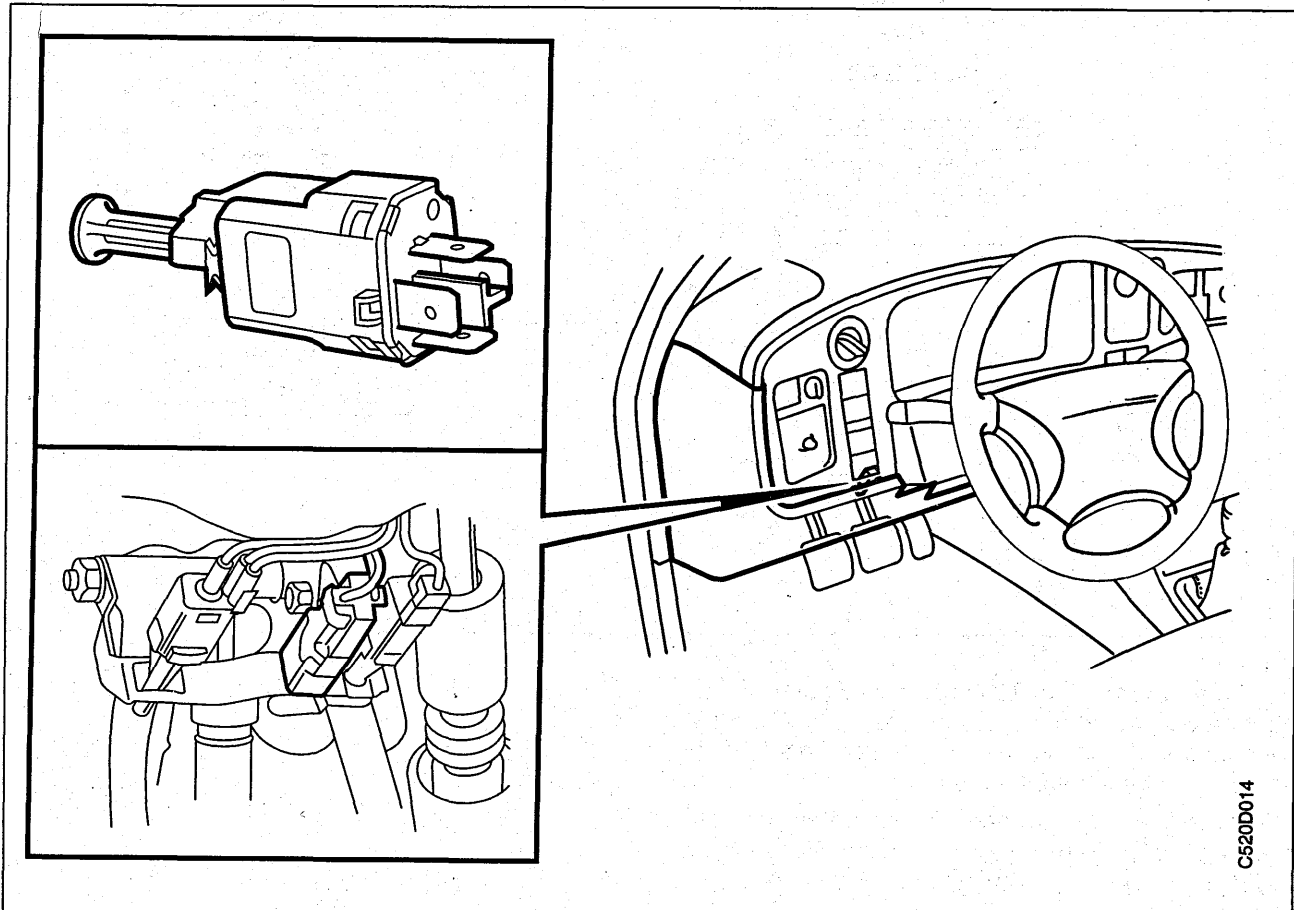

With effect from M1997 the LHD Saab 9000 has the same brake lights switch as the Saab 900.

As a result of the changed brake lights switch, the pedal assembly has also been changed.

To remove

- 1 Remove the lower section of the dashboard on the driver's side.
- 2 Turn the brake lights switch in either direction and lift it out.
- 3 Unplug the connector.

To fit

- 1 Fit the connector onto the switch.
- 2 Depress the brake pedal and fit the brake lights switch in position on the pedal assembly by turning it in either direction.

3 Refit the lower section of the dashboard.

Rear fog light

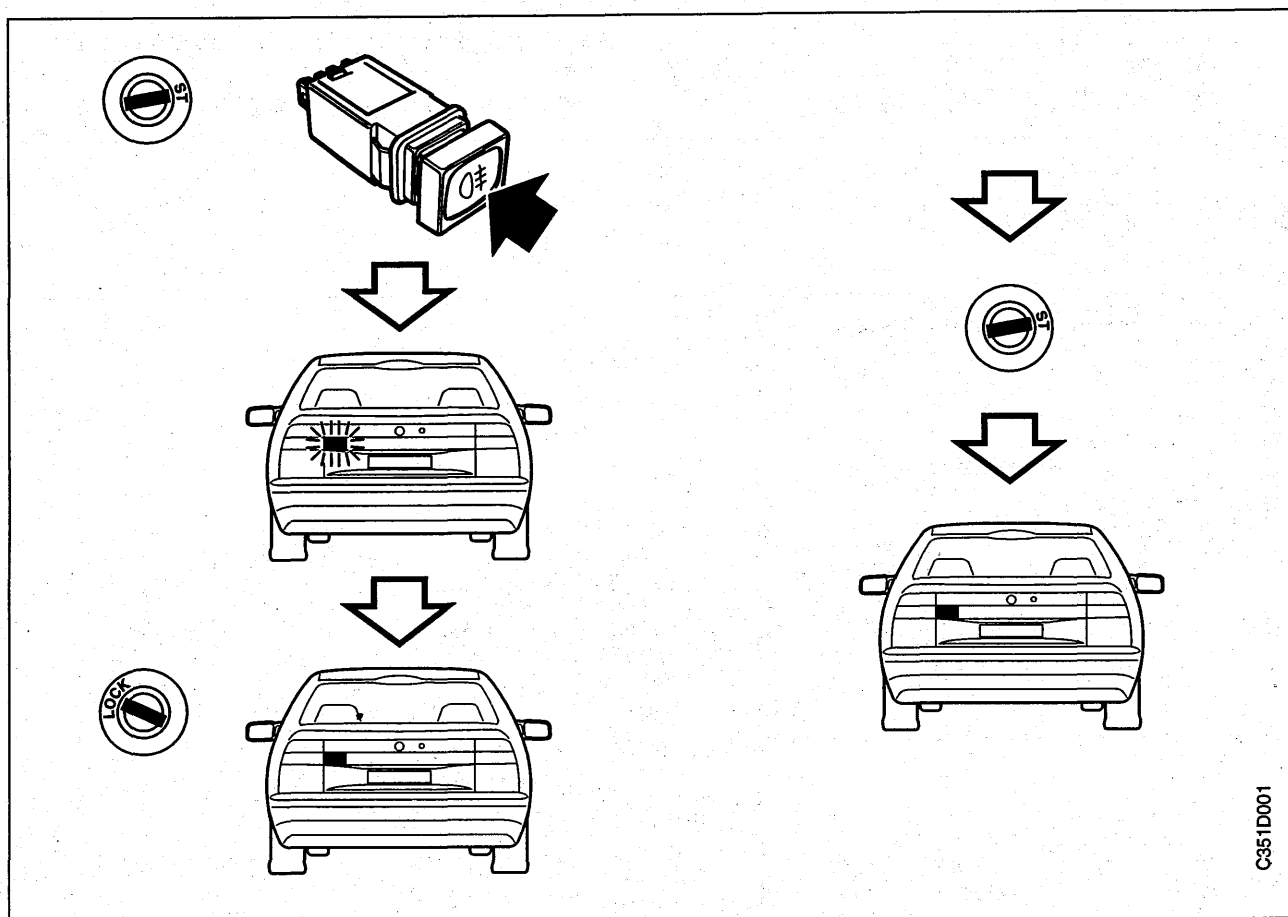

M1997 and later Saab 9000 cars are equipped with a rear fog light that goes out automatically when the ignition is switched off. To turn the rear fog light on again its button must be pressed.

This modification has been introduced so that the driver will not unknowingly drive the car with the rear fog light switched on but must turn it on as necessary.

New components are a rear fog light relay (246) and the switch, which is replaced by one that is spring-loaded.

Pressing the button causes the relay to operate and remain operated until the ignition is switched off.

For more information, see the following wiring diagram and tables.

Rear fog light, US/CA wiring diagram

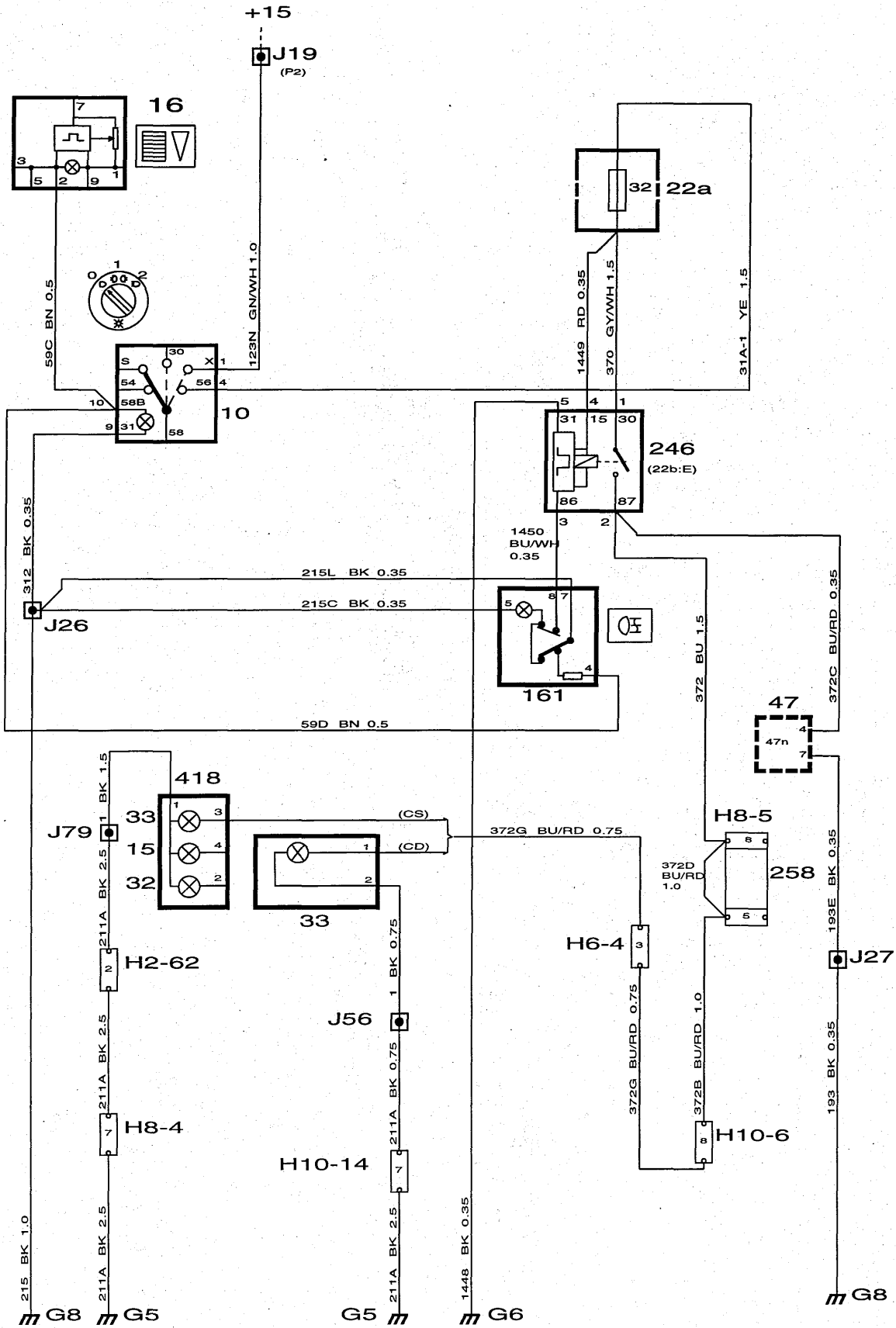

Rear fog light, wiring diagram for other markets

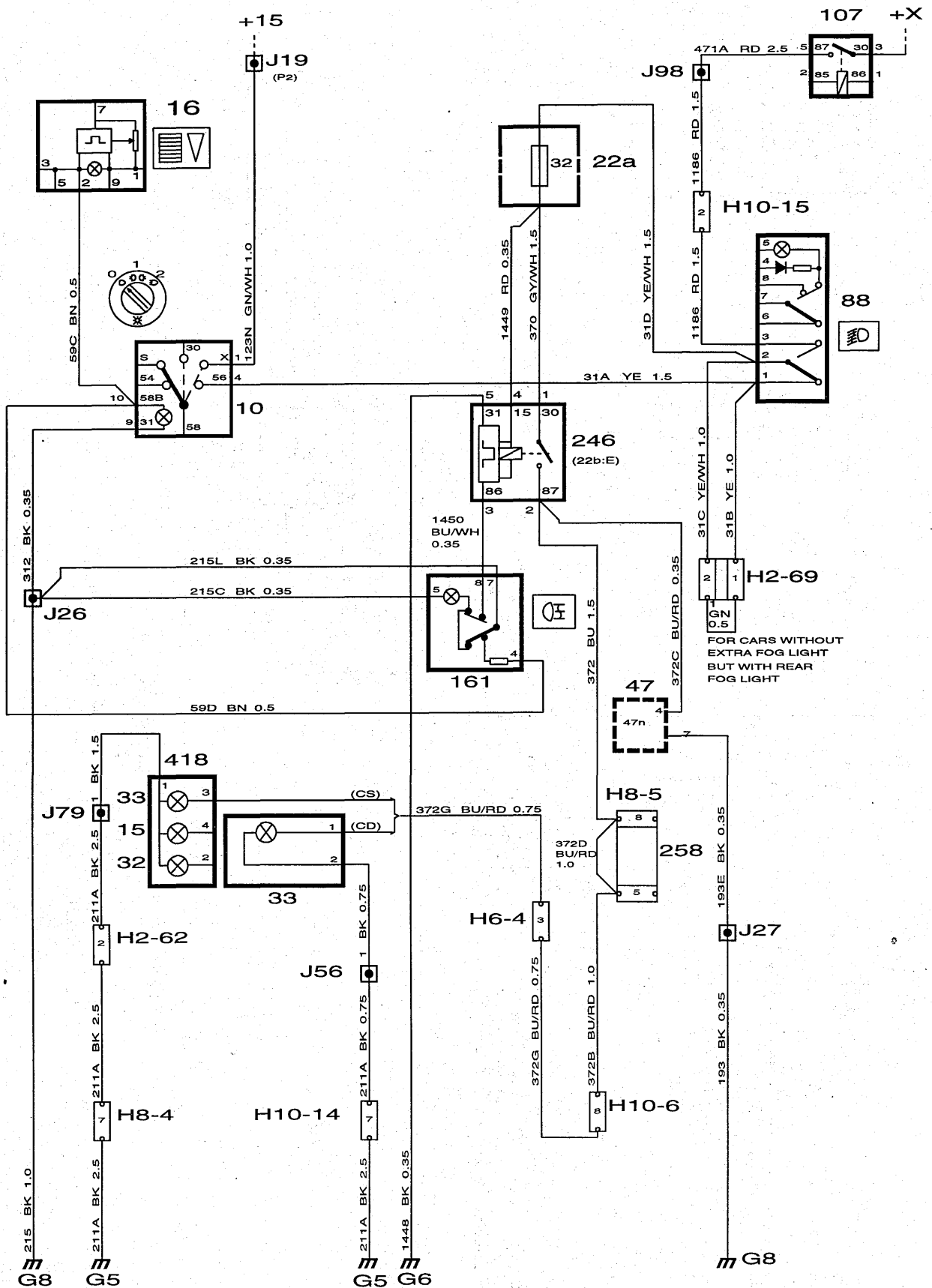

Relay table, main fuse box, glove box

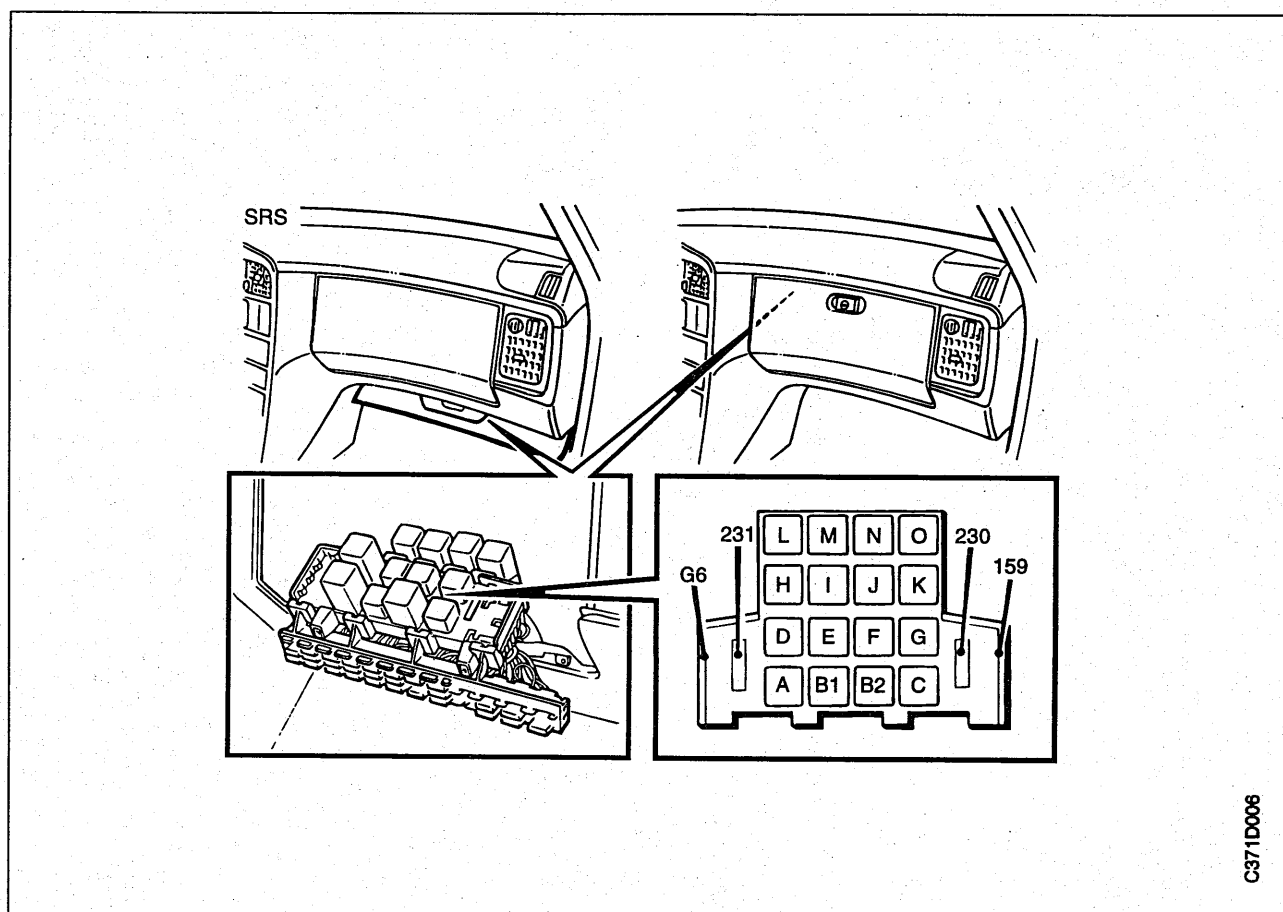

C371D006

159 Distribution terminal +15 circuit
 230 Distribution terminal +30 circuit
 231 Distribution terminal +54 circuit
 G6 Distribution terminal negative

Location	No.	Function
A	82	Relay, Seat-belt/ignition key warning
B1	437	Relay, Parking lock
B2	83a	Relay, Intermittent wiper operation, rear window
C	432	Relay, Washer pump, rear
D	102	Relay, Fuel pump
E	246	Relay, Rear fog light
F	405	Relay, Reversing lights
G	21	Relay, Ignition switch
H	229	Relay, Engine management system

I	113	Relay, Electrically heated rear window
J	-	-
K	452	Relay, Starter motor interlock, anti-theft alarm
L	83	Relay, Intermittent wiper operation, windscreen
M	151	Relay, Interior lighting with time delay
N	23	Relay, Direction indicators
O	174	Relay, Daylight driving lights, US/CA

Suspension and wheels

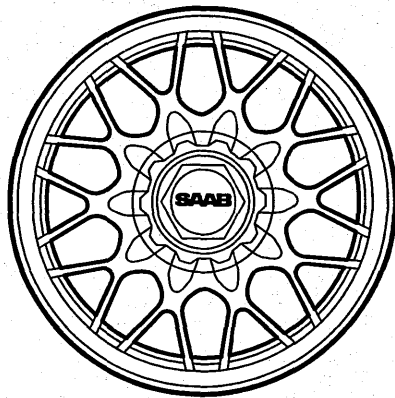
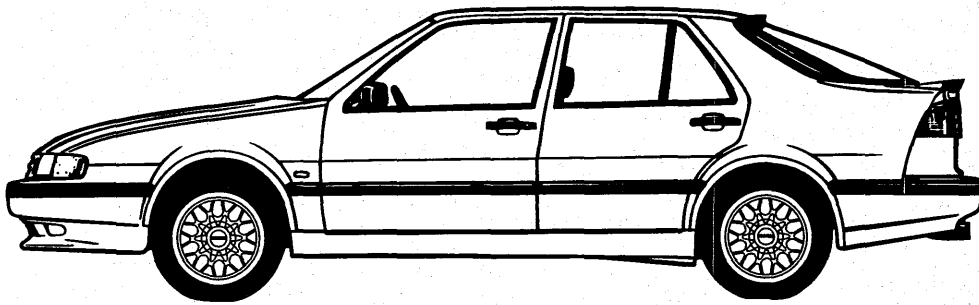

C771D001

A new aluminium wheel is introduced as an optional accessory for the M1997 Saab 9000. This is a Cross-Spoke wheel and its size is 15" x 7".

Body

Body colours	17	Engine type emblem	20
Side collision protection	18	Aero spoilers	20
Chassis number (V.I.N.) plate	19	Rear window wiper and washer	20

Body colours

Three new body colours have been introduced for M1997: Cayenne Red, Midnight Blue and Amethyst Violet.

These colours are metallic and replace Le Mans Blue and Ruby Red, which have now been discontinued.

The current range of colours is shown in the table below:

Colour code	Colour	Paint type	Remarks
153	Cirrus White	Solid	
170	Black	Solid	
198	Embassy Blue	Solid	
227	Citrine Beige	Metallic	
230	Scarab Green	Metallic	
240	Imola Red	Solid	
247	Silver	Metallic	
252	Sky Blue	Metallic	
254	Willow Green	Metallic (Mica)	
256	Cayenne Red	Metallic (Mica)	New colour
257	Midnight Blue	Metallic (Mica)	New colour
258	Amethyst Violet	Metallic (Mica)	New colour

The Saab 9000 Aero is available only in the following colours:

- Black
- Scarab Green
- Imola Red
- Silver
- Midnight Blue

Side collision protection

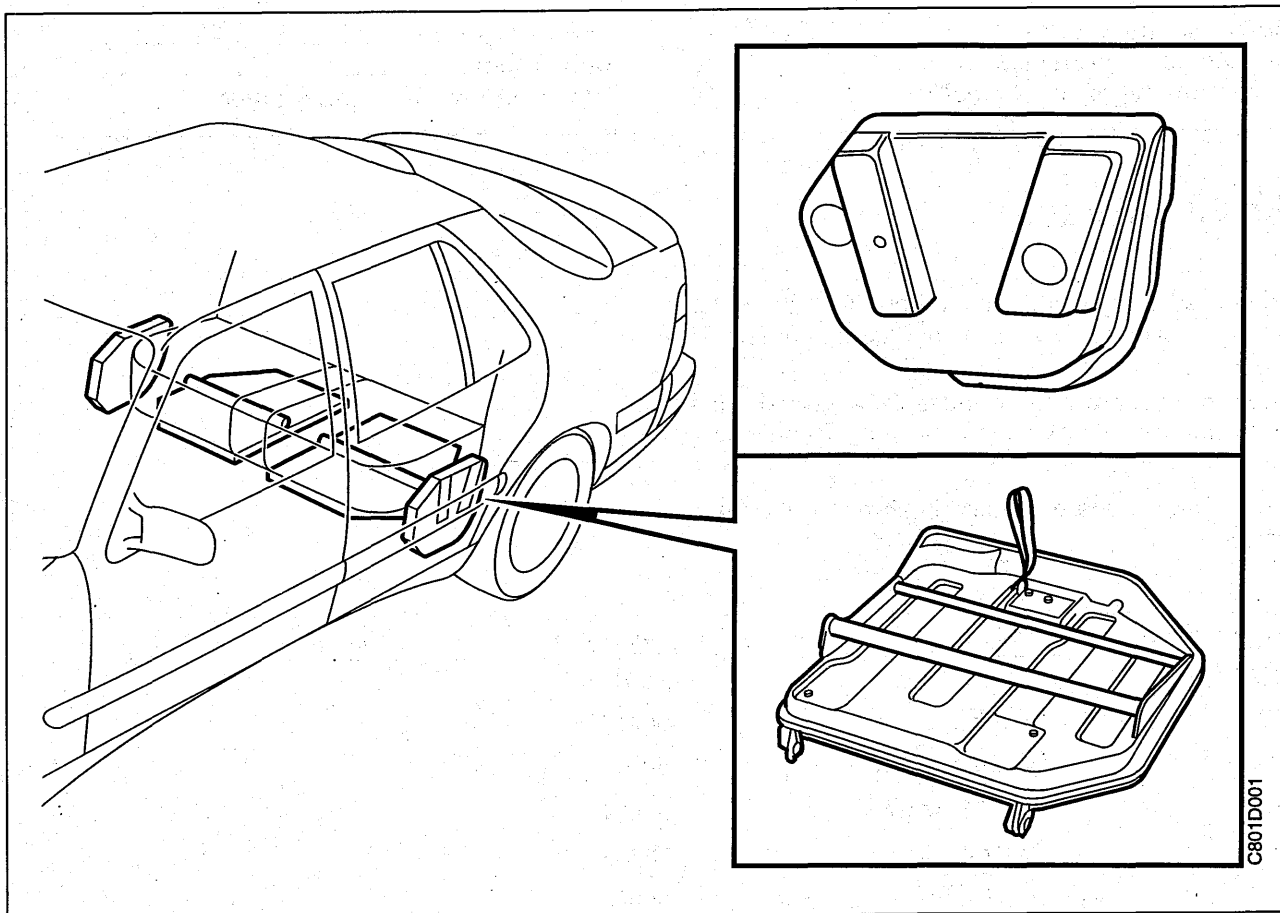

Starting with M1997, the Saab 9000 will have an even higher degree of safety in a side collision. Foam blocks are now fitted between the inner and outer rear door panels and on the inside of the rear door trim.

The foam blocks are fitted in the rear doors between the inner and outer panels and secured by means of a blind rivet through the hole in the inner panel.

The foam blocks on the inside of the rear door trim are glued directly to the trim.

On CS/CSE/Aero models the rear seat is reinforced with an extra tubular structure.

Important

Always refit the foam blocks in the doors if they have been removed. The inner door trim must not be replaced by trim of earlier type without side collision protection.

This is extremely important as the car will otherwise not offer the same standard of safety in the event of a side collision.

Chassis number (V.I.N.) plate

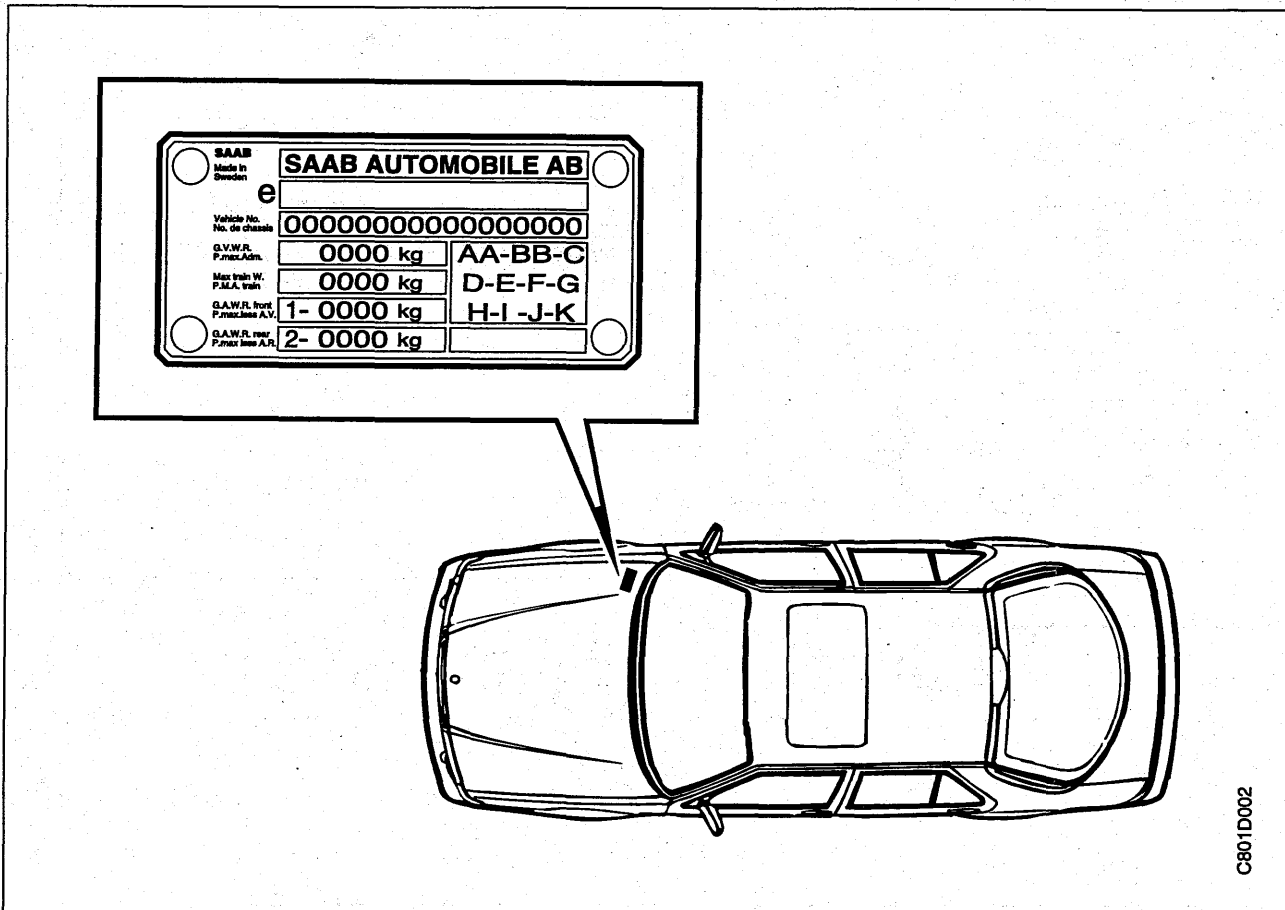

With effect from M97 the chassis number (V.I.N.) plate has been changed and now contains a space for the code designations of certain spare parts to facilitate their replacement. These codes can be found in the notes column in the spare parts catalogue (see example below).

- Pos. 1 (AA) Spring, front
- Pos. 2 (BB) Spring, rear
- Pos. 3 (C) Anti-roll bar, front
- Pos. 4 (D) Anti-roll bar, rear
- Pos. 5 (E) MacPherson strut, front
- Pos. 6 (F) Damper, rear
- Pos. 7-11 (G-K) —

Example:

**Front suspension
1997-**

**Främre fjädring
1997-**

Pos.	Part No./Art nr	Notes/Anmärkningar	Qty/ Antal	Description	Benämning
1	44 83 160	CODE=AG.....	2	Spring..... red/red.....	Fjäder..... röd/röd.....
1	44 83 178	CODE=AH.....	2	Spring..... yellow/red.....	Fjäder..... gul/röd.....
1	44 83 186	CODE=AJ.....	2	Spring..... red/white.....	Fjäder..... röd/vit.....

Engine type emblem

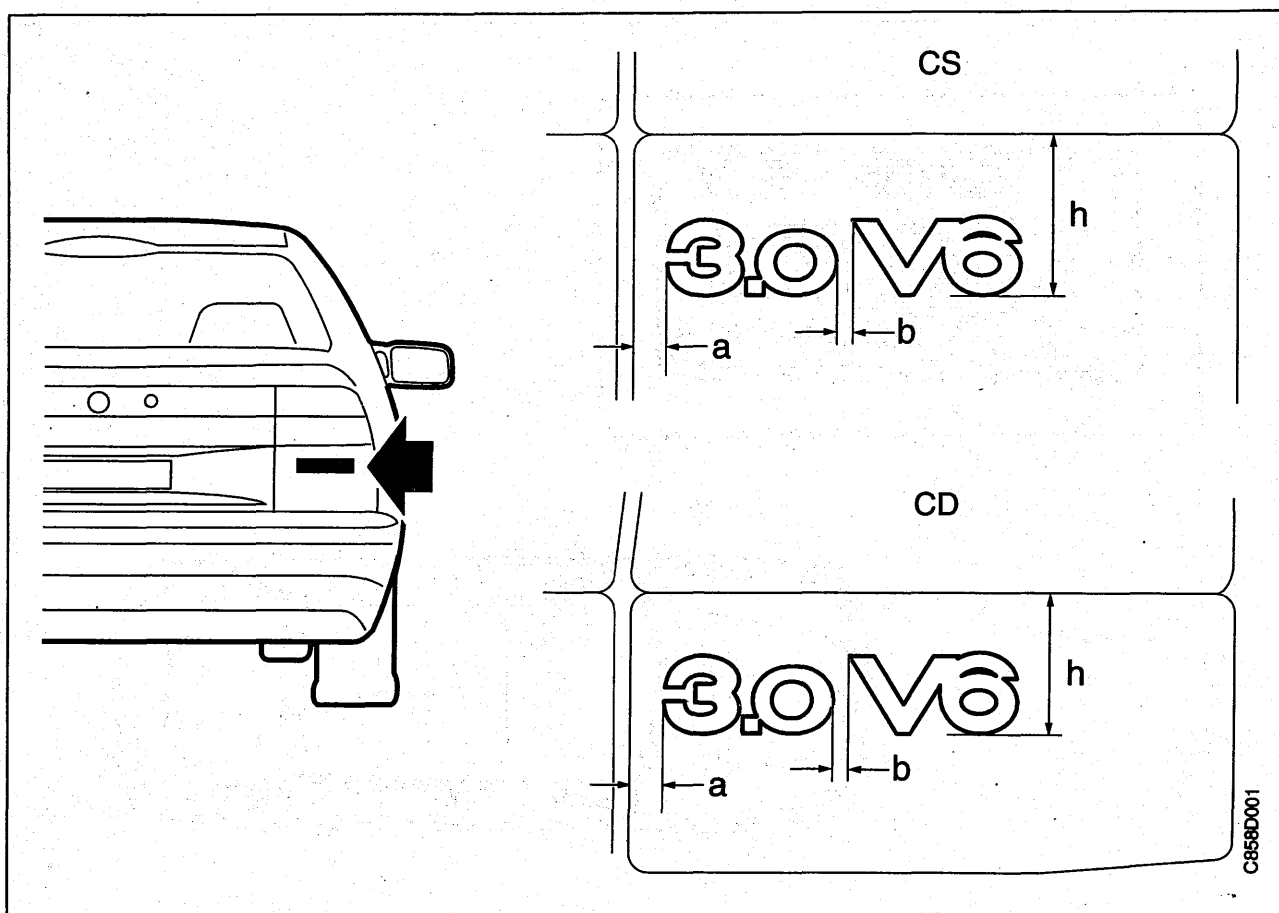

On M1997 Saab 9000 cars the engine type emblem previously mounted on the front grille is now affixed to the corner panel adjacent to the tailgate. Its location will be evident from the illustration and table of measurements.

		V6	t	Turbo
CS	a	12 mm	12 mm	12 mm
	b	4 mm	4 mm	3 mm
	h	50 mm	50 mm	50 mm
CD	a	12 mm	12 mm	12 mm
	b	4 mm	4 mm	3 mm
	h	40 mm	40 mm	40 mm

Aero spoilers

All M1997 Saab 9000 US/CA CSE cars are equipped with Aero spoilers.

Rear window wiper and washer

A rear window wiper and washer will be standard equipment on all CS/CSE/Aero models.

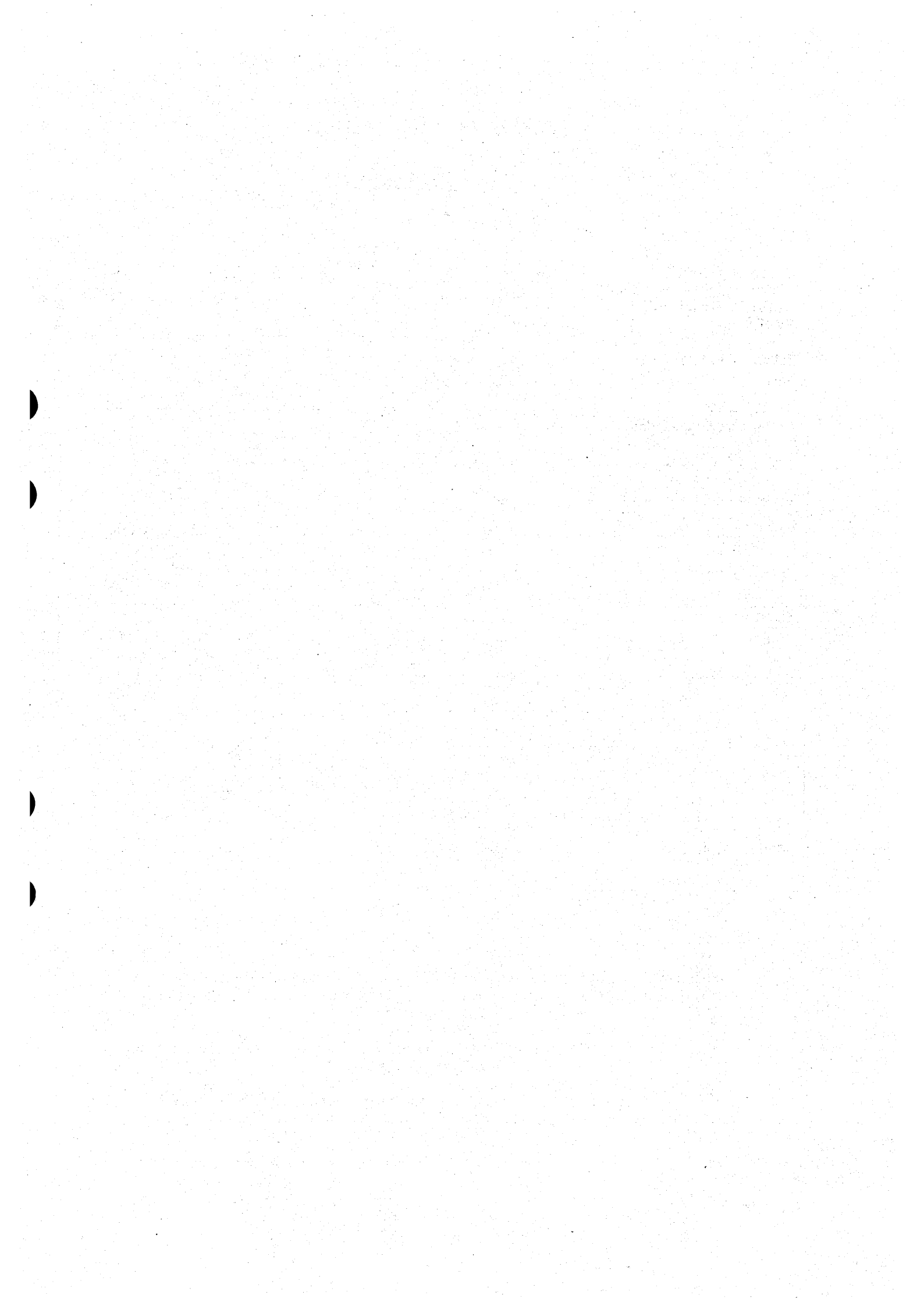

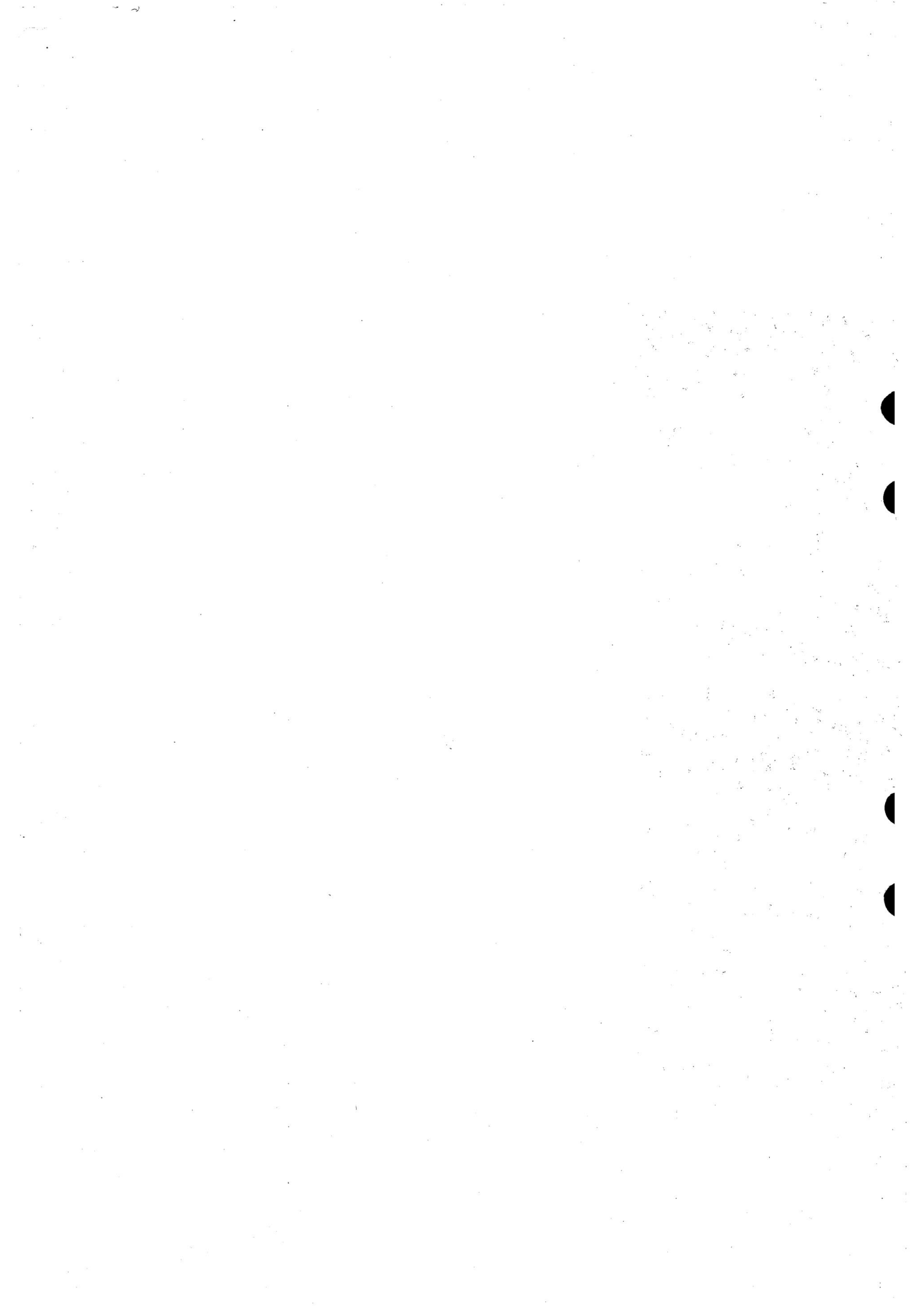



SAAB

Saab Automobile AB
Trollhättan, Sweden

Ordering No. 366997. English edition. Printed in Sweden. © Saab Automobile AB, 1996.

