

Saab 9000

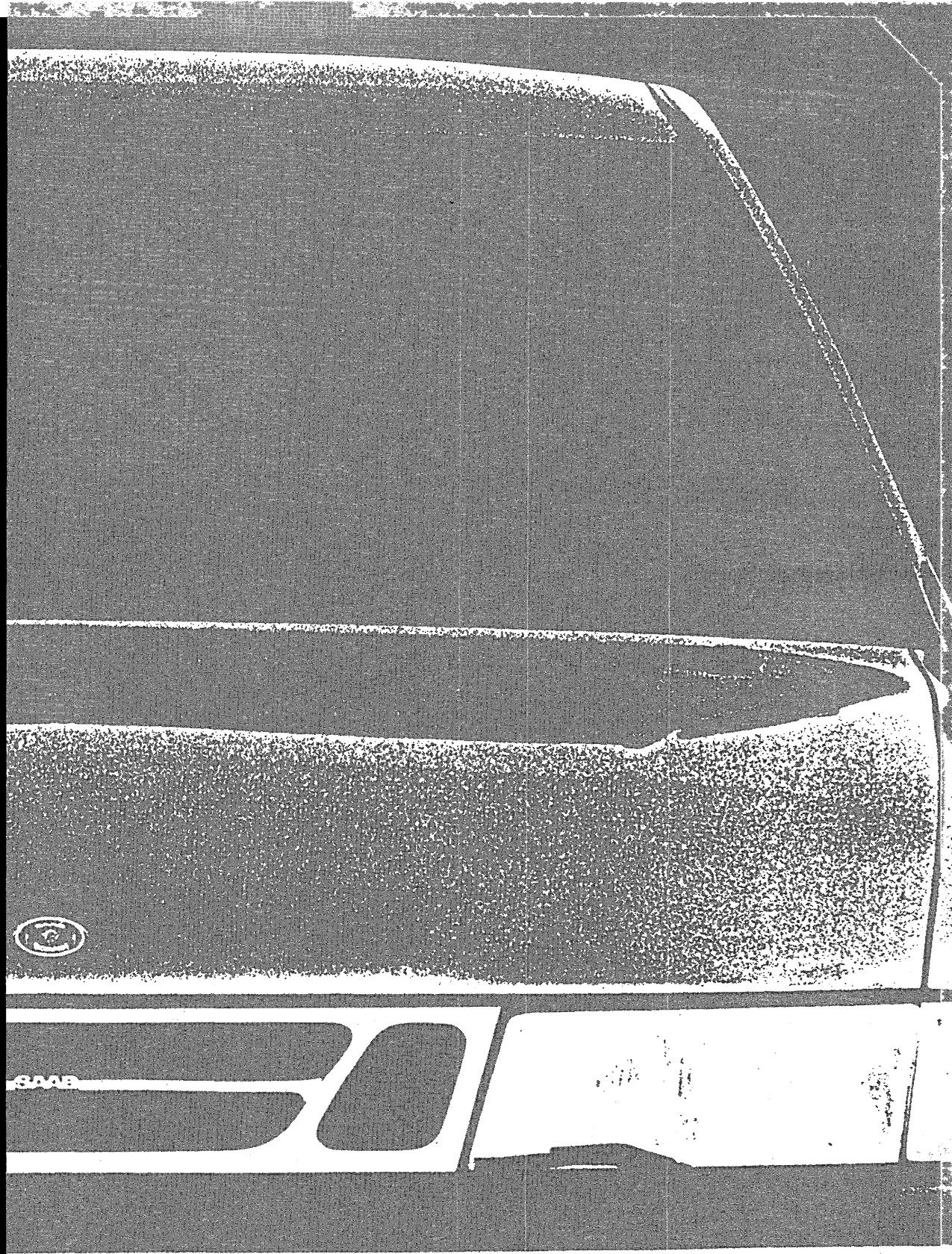

Service Manual

0 News

M1998-
Edition 2

ENG



SAAB



SAAB

0 NEWS

General information

Important

Warning, Important and Note

The headings "Warning", "Important" and "Note" occur from time to time in the Service Manual. They are used to draw the attention of the reader to information of special interest and seriousness. The importance of the information is indicated by the three different headings and the difference between them is explained below.

 **WARNING**

Warns of the risk of material damage and grave injury to mechanics and the driver, as well as serious damage to the car.

Important

Points out the risk of minor damage to the car and also warns the mechanic of difficulties and time-wasting mistakes.

Note

Hints and tips on how the work can be done in a way that saves time and effort.

This information is provided as a means of improving efficiency, not for reasons of safety.

Market codes

The codes refer to market specifications.

AT	Austria
AU	Australia
BE	Belgium
CA	Canada
CH	Switzerland
CN	China
DE	Germany
DK	Denmark
ES	Spain
EU	Europe
FI	Finland
FR	France
GB	Great Britain
GR	Greece
IE	Ireland
IL	Israel
IS	Iceland
IT	Italy
JP	Japan
LA	Latin America
ME	Middle East
MT	Malta
NL	Netherlands
NO	Norway
PA	Asia/Pacific region
PT	Portugal
RU	Russia
SE	Sweden
TR	Turkey
US	USA
UC	US California
ZN	New Zealand

Technical data

VIN (Vehicle Identification Number) M1998

Example: YS3CD65UXW1001234

1 - Geographical region	Y = Northern Europe
2 - Country	S = Sweden
3 - Manufacturer	3 = Saab Automobile AB
4 - Product line	C = 9000
5 - Model series	C = Saab 9000CS with driver airbag D = Saab 9000CS with driver and passenger airbag E = Saab 9000CSE with driver airbag F = Saab 9000CSE with driver and passenger airbag
6 - Body version	6 = 5-door
7 - Gearbox	5 = 5-speed manual 8 = 4-speed automatic
8 - Engine variant	J = B204I T = B204E U = B234E M = B234L R = B234R
9 - Check digit	0 - 9 or X
10 - Model year	W = 1998
11 - Place of manufacture	1 = Trollhättan
12 - Serial number	000001-999999

Engine number

	Example: B234ECM00 W123456	
Pos 1	Bxxxxxxx xxxxxx	Engine type: B = Petrol engine
Pos 2-3	x23xxxxxx xxxxxxx	Stroke: 20 = 1.985 dm ³ 23 = 2.290 dm ³
Pos 4	xxx4xxxx xxxxxxx	Cylinder head: 4 = 4 cylinders, in-line with 2 balancer shafts and cylinder head with 2 camshafts and 4 valves per cylinder.
Pos 5	xxxxExxxx xxxxxxx	Version: I = Fuel injection E = Turbocharged engine with charge air cooler. Light pressure turbo. Power 2. L = Turbocharged engine with charge air cooler. Power 1. R = Turbocharged engine with charge air cooler. Power 2.
Pos 6	xxxxxCxxx xxxxxxx	Exhaust emission control specification: C = Saab 9000.
Pos 7	xxxxxMxx xxxxxxx	Transmission: A = Automatic transmission. M = Manual gearbox.
Pos 8-9	xxxxxxx00 xxxxxxx	Variant: 00 = Basic model 20 = Engine with OBD II.
Pos 10	xxxxxxxx Wxxxxxx	Model year designation according to ISO 3779: W = 1998
Pos 11-16	xxxxxxxx x123456	Serial number: Serial number in model year.

Service

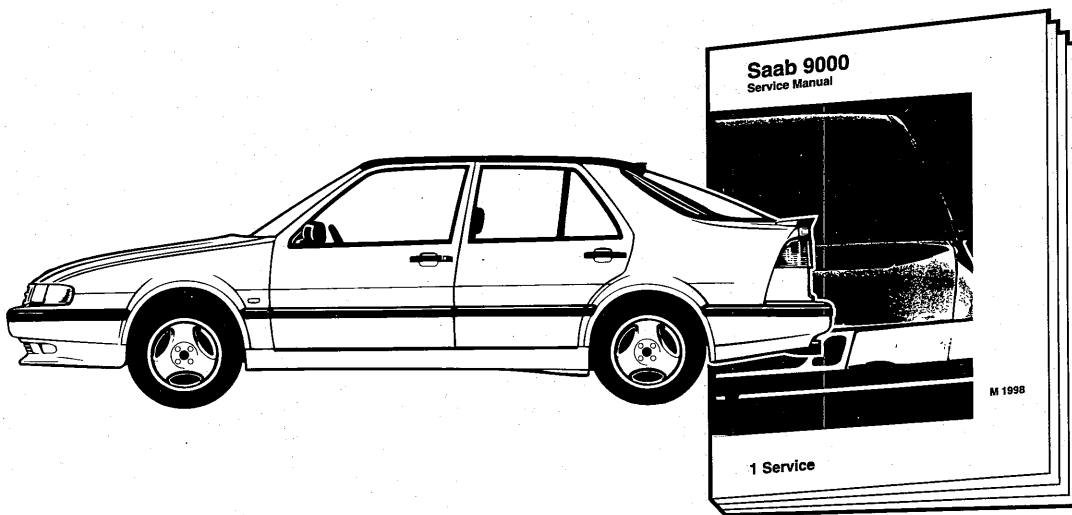

C801D003

Additional pre-delivery service points:

- For the Sweden and Finland markets: A child seat label should be affixed to the dashboard on cars with a passenger-side airbag.
- Retightening of cylinder-head bolts (SI 210-1705) has been changed from service No. 1 (10,000 km) to pre-delivery service.



Wheels and tyres

Wheels

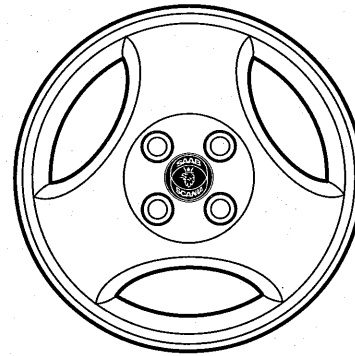
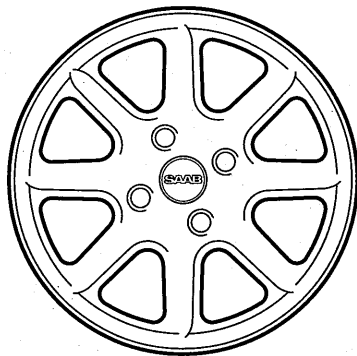
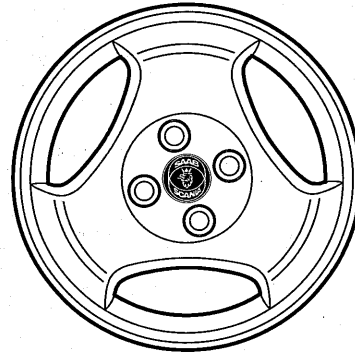
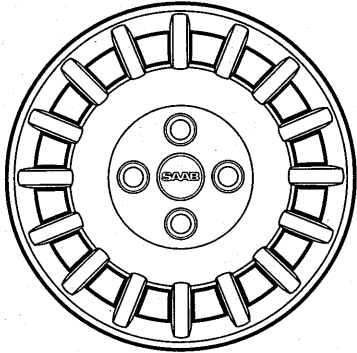

C771D002

A new 3-spoke wheel has been introduced to replace the 3-spoke wheel that has been fitted since M96. The new wheel will continue the sports line with exposed wheel bolts which was introduced for M97.

In addition, a new full-size wheel cover, also with exposed wheel bolts, has been introduced. This new wheel cover replaces the earlier wheel cover.

The 3-spoke Aero wheel has been redesigned so that it now also has exposed wheel bolts.

The 8-spoke wheel remains unchanged.

8 Wheels and tyres

Air pressure

Starting with M98 the recommended tyre inflation pressures have been changed.

Tyre size	Load	Speed km/h	Front		Rear	
			bar	(psi)	bar	(psi)
195/65 R15 91V	1-3 persons	0-160	2.2	32	2.2	32
	Max load	0-160	2.2	32	2.2	32
	Max load	160-	2.6	38	2.6	38
205/60 R15 91V	1-3 persons	0-160	2.1	30	2.1	30
	Max load	0-160	2.1	30	2.1	30
	Max load	160-	2.6	38	2.6	38
205/55 R16 91V	1-3 persons	0-160	2.2	32	2.2	32
	Max load	0-160	2.2	32	2.2	32
	Max load	160-	2.6	38	2.6	38
205/55 R16 91W	1-3 persons	0-190	2.4	35	2.4	35
	Max load	0-190	2.4	35	2.4	35
	Max load	190-	2.5	36	2.5	36

Body

Finish paints

The range of colours for model year 1998 is listed in the table below.

Colour code	Colour	Paint type	Remarks
153	Cirrus White	Solid	
170	Black	Solid	
198	Embassy Blue	Solid	
230	Scarabee Green	Metallic	
240	Imola Red	Solid	
256	Cayenne Red	Metallic	Mica
257	Midnight Blue	Metallic	Mica
268	Silver	Metallic	

Tailgate

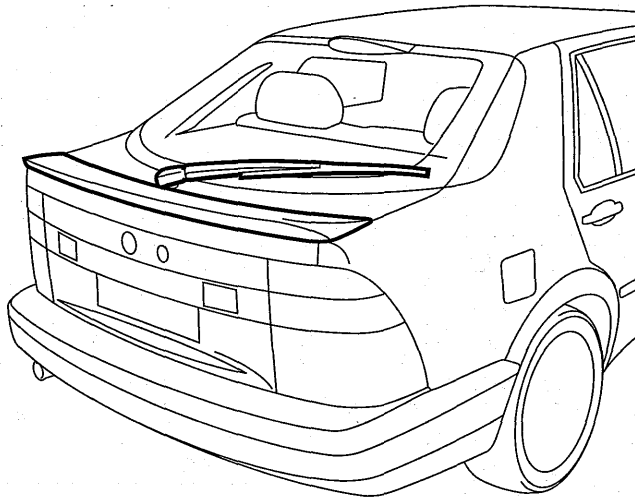

C845D001

The tailgate with spoiler is obtainable only in combination with a rear window wiper.

The tailgate with a rear window wiper only and no spoiler has been discontinued.

Air conditioning (A/C)

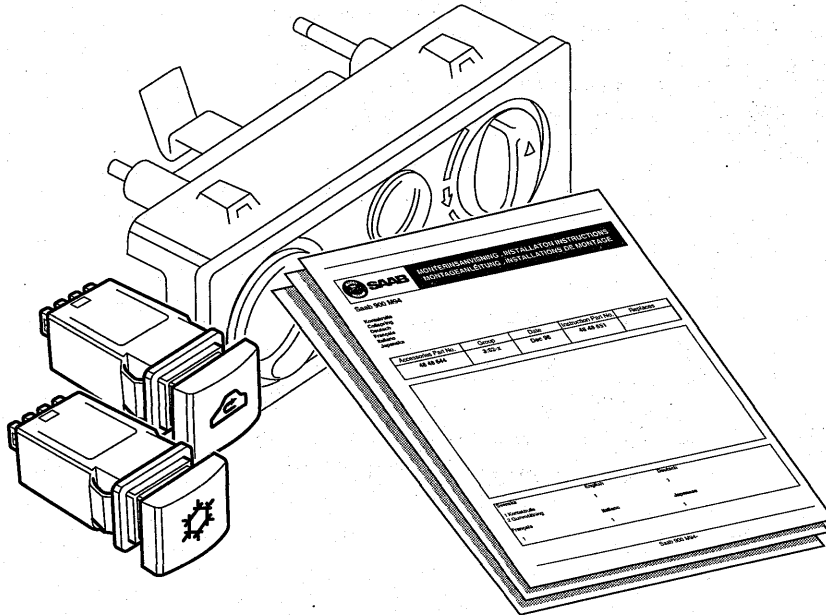

C854D001

Starting with model year 1998, air conditioning (A/C) will be discontinued.

The car is pre-wired for subsequent fitting of air conditioning (A/C) as an optional accessory.

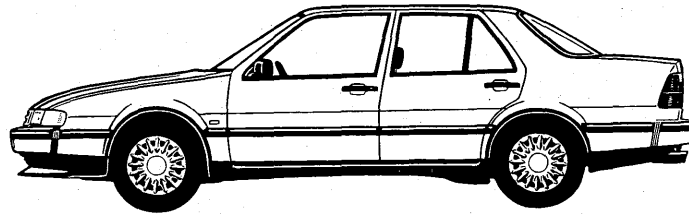
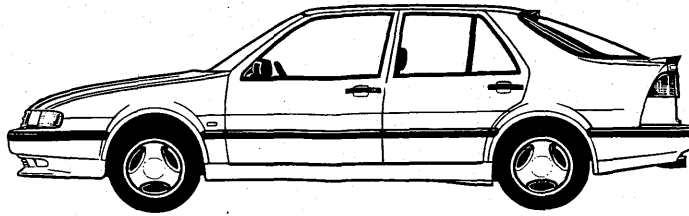

C801D004

Saab 9000 CD and Saab 9000 Aero

Starting with model year 1998 the Saab 9000 CD and Saab 9000 Aero will be discontinued.

An exterior Aero equipment package, combined with 16" wheels, will be available from model year 1998 1/2.



SAAB

Saab Automobile AB, Trollhättan, Sweden

ENG

Ordering No. 374231. English edition. Printed in Sweden. © Saab Automobile AB 1997.

Saab 9000