

**SAAB**

**9000**

**SERVICE  
MANUAL**

**3:1** Electrical system,  
instruments

**M 1987-**

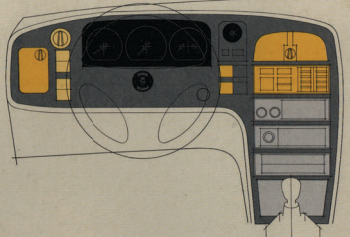
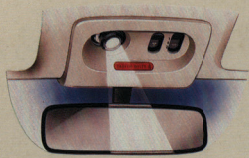
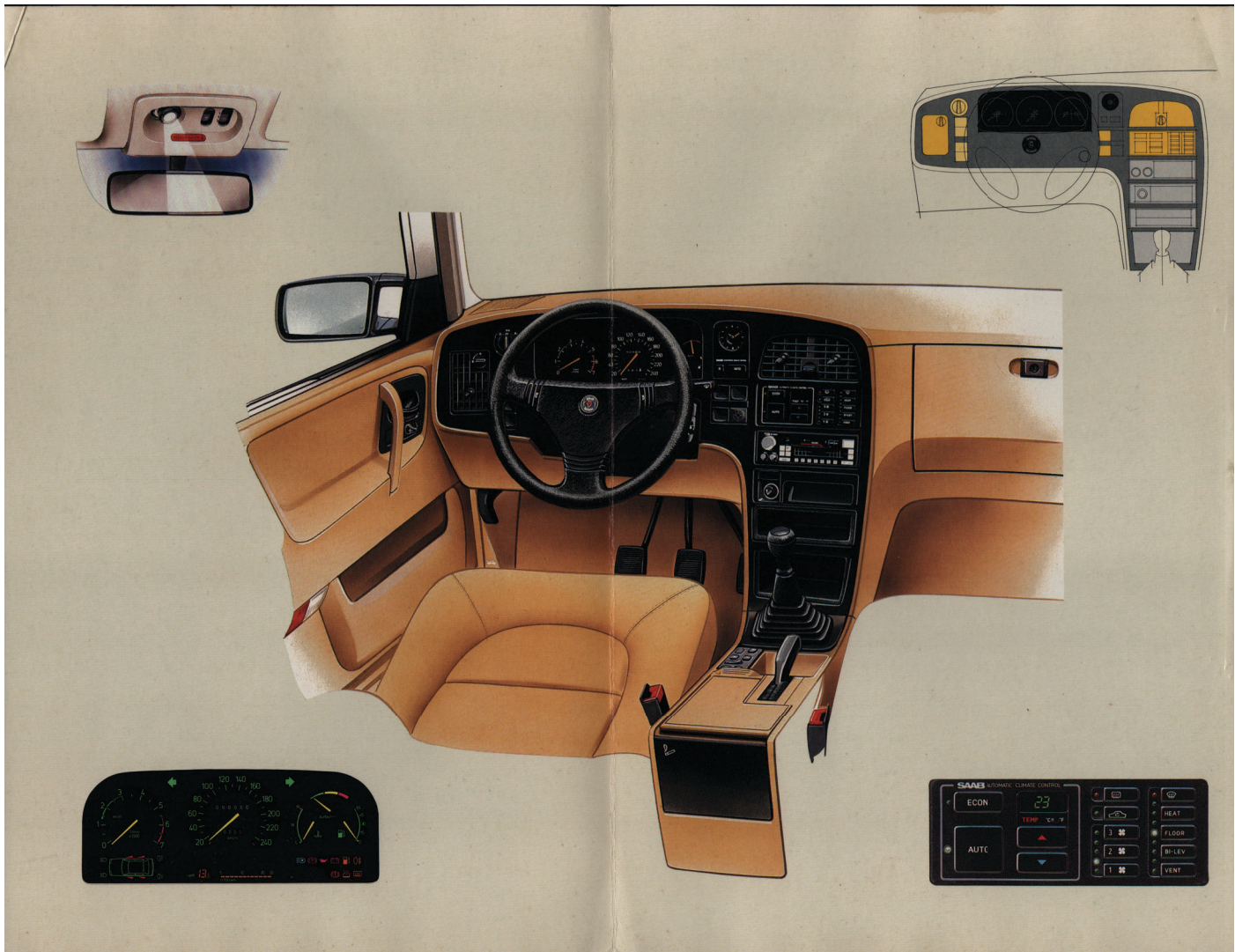



## Units

The basic units as well as the derived units used throughout the Service Manual are in accordance with the SI system.

As a supplement to these, a number of other units are specified within brackets.

The following symbols for the various units have been used in this issue:

SI unit	Supplementary unit unit
mm	in
kg	lb
N	lbf
Nm	lbf ft
bar	psi
l	qt (US)
°C	°F

## Conversion factors

1 in = 25,4 mm	1 mm = 0.039 in
1 lbf = 4,45 N	1 N = 0,23 lbf
1 lbf ft = 1,36 Nm	1 Nm = 0,74 lbf ft
1 psi = 0,07 bar	1 bar = 14,5 psi
1 qt = 0,95 l	1 l = 1,05 qt

## Codes for different markets

The specified codes refer to the market variants of the cars

AT	Austria	FR	France
AU	Australia	GB	Great Britain
BE	Belgium	GR	Greece
CA	Canada	IS	Iceland
CH	Switzerland	JP	Japan
DE	Germany	IT	Italy
DK	Denmark	ME	Middle East
ES	Spain	NL	Holland
EU	Europe	NO	Norway
FE	Far East	SE	Sweden
FI	Finland	US	U.S.A.

# Technical data

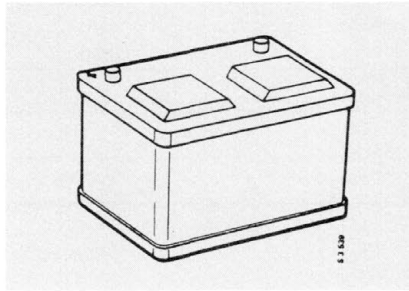

## Battery

Voltage	V	12
Capacity	Ah	62
Polarity		Negative (-) earth
Specific gravity of electrolyte:		
when recharging required		1.21
when battery fully charged		1.28

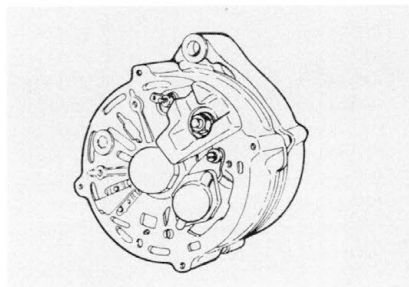

## Alternator

### Bosch N1-14V 80 A 19

Rated voltage	V	14
Rated speed	r/min	1900
Stator connection		Star connection 
Slip ring diameter, new	mm (in)	27.8 (1.09)
minimum	mm (in)	26.8 (1.06)
Maximum permissible slipring runout	mm (in)	0.03 (0.001)
Maximum permissible rotor runout	mm (in)	0.05 (0.002)
Minimum brush length	mm (in)	5 (0.2) (protruding from brush holder)
Reduction ratio between crankshaft pulley and alternator		1:2.4

**Test values**

Resistance, rotor winding	Ohm	$2.8 \pm 10\%$
between stator phases	Ohm	$0.10 \pm 10\%$
Current output at:		
At 1 500 r/min	A	36
At 1 900 r/min	A	54
At 6 000 r/min	A	80

**Belt tension**

New belt	N (lbf)	$800 \pm 45$ ( $184 \pm 10$ )
Minimum	N (lbf)	355 (82)
After adjusting	N (lbf)	$535 \pm 45$ ( $123 \pm 10$ )

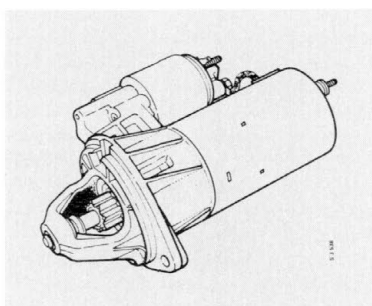
**Starter motor**

Type		Bosch DW 12V 0 001 108 038
Rating	kW (hp)	1.4 (1.9)
Number of teeth on pinion		9
Number of teeth on ring gear		142
Reduction ratio engine/starter motor		1:15.8

**Test values, mechanical**

Backlash in gear train	mm (in)	0.35 - 0.60 (0.014-0.024)
Clearance between pinion and ring gear	mm (in)	2.5 - 3.0 (0.1-0.12)
Rotor end float	mm (in)	0.05 - 0.40 (0.002-0.016)
Torque of freely rotating pinion	Nm (lbf ft)	0.12 - 0.18 (0.09-0.13)

### Test values, electrical

Idling, 12 V and 70 A	r/min	3 000
Speed under load, 9 V and 315 A	r/min	1 700
Starter motor locked, 4 V and 650 - 750 A	r/min	0
Minimum voltage for solenoid energising	V	7

### Tightening torques

Solenoid securing bolts	Nm (lbf ft)	4.5 - 5.5 (3.3-4.1)
Commutator end bracket securing bolts (long)	Nm (lbf ft)	2.7 - 3.5 (2.0-2.6)

### Ignition system

Type	Breakerless incorporating a Hall transducer
Firing order	1-3-4-2

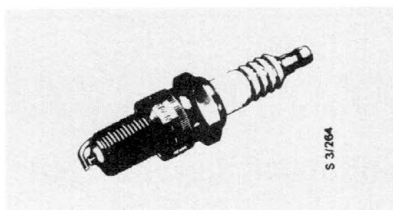

### Spark plugs

Engine	Type	Remarks
Turbo 16	Champion C7GY NGK BCP 7EV NGK BCP 7ES Champion C7YC Bosch F6DC	
Injection 16	NGK BCP 6ES Champion C9YC Bosch F7DC	
Replacement interval, US others	km (miles) km (miles)	50 000 (30 000) 20 000 (12 000)
Electrode gap	mm (in)	0.6 (0.02)
Tightening torque (non-lubricated plug)	Nm (lbf ft)	25-29 (18.5-21.5)

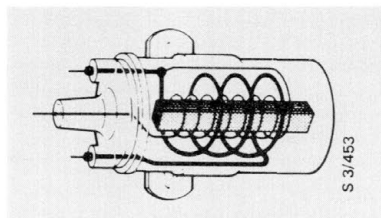

### Ignition coil

Resistance of primary winding measured between terminals 1 and 15	Ohm	0.52 - 0.76
Resistance of secondary winding measured between terminal 1 and the HT output terminal	kOhm	7.2 - 8.2

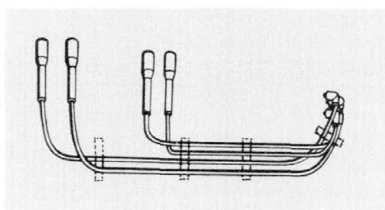

### HT leads

Resistance of lead (including connectors) between coil and distributor	kOhm	0.5 - 1.5
Resistance of lead (including connectors) between distributor and plug	kOhm	2 - 4

### Ignition setting with vacuum control unit disconnected

Engine	Timing at r/min	Remarks
Turbo 16	16° BTDC/850	
Injection 16	14° BTDC/850	



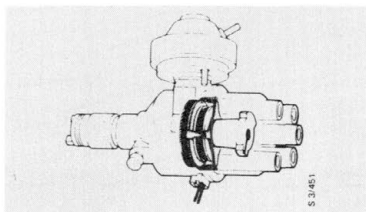

## Distributor

Type	Turbo	Bosch 0 237 507 007
	injection	Bosch 0 237 506 009
Direction of rotation		Anticlockwise
Rotor arm resistance	kOhm	1

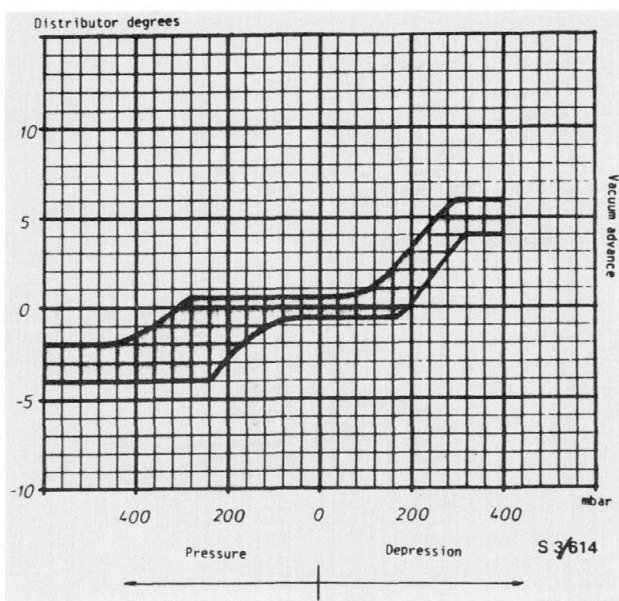

Characteristic of Bosch 0 237 507 007 distributor

## Amplifier

Type	Turbo	Bosch 0 227 100 139
	injection	Bosch 0 227 100 124

## Lighting

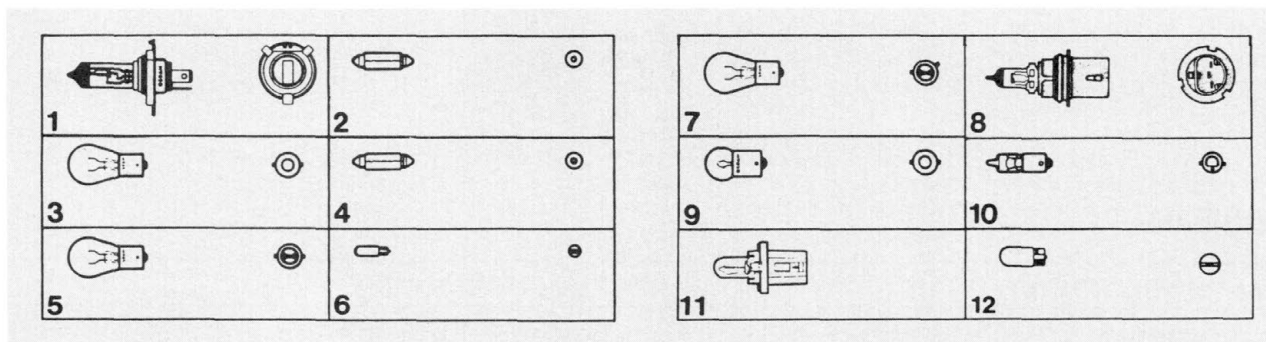

			Socket	Item
Headlamps	W	60/55	H4 holder P43t-38	1
Headlamps (US, JP)	W	70/50	Sylvania 9004 DOT 12V	8
Rear direction indicators, stop lights, reversing lights, high-level brake light*	W	21	BA 15s	3
Front direction indicators/side marker lights*, corner lights*/parking lights	W	21/5	BAY 15d	5
Rear fog lights*/rear lights	W	21/4	BAZ 15d	7
Rear lights	W	5	BA 15s	9
Number plate illumination, interior lighting rear-view mirror, glove compartment lamp, centre console lamp, courtesy lamps, seat-belt warning lamp	W	5	SV 8.5-8	2
Roof lamp and luggage compartment lamp	W	10	SV 8.5-8	4
Illumination of switches and front ashtray	W	1.2	W2x4.6d	6
Warning/indicating lamps for oil pressure, brakes, direction indicators, rear-window heater, high beam, handbrake, washer fluid level, pictogram, shift up indicator* rear fog lights*, anti-lock brakes*, check engine*	W	1.12	bulb with bulb holder	—
Fuel warning lamp	W	1.2	bulb with bulb holder	11
Charging warning lamp	W	2.0	bulb with bulb holder	11
Illumination of heating and ventilation controls and cigarette lighter	W	2	W2 x 4.6d	6
Instrument lighting	W	3	bulb with bulb holder	—
Spotlight in front roof console, reading lamps on C pillars	W	5	halogen	10
Side direction indicators	W	5	W2.1 x 9.5	12
Engine compartment illumination	W	15	SW8.5	4

\* Only on certain markets and models

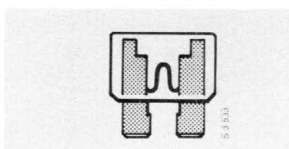

## Fuses

Red	A	10
Blue	A	15
Yellow	A	20
Transparent	A	25
Green	A	30

## Other electrical equipment

### Windscreen wiper motor

Speed (double strokes per minute) and current consumption at 13,5V			
Wet glass, half-speed	r/min	$44 \pm 4$	$\leq 3 \text{ A}$
Wet glass, full speed	r/min	$64 \pm 6$	$\leq 4 \text{ A}$
Current consumption, motor locked (e.g. wiper blades frozen to glass)	A	approx. 20	

### Headlamp wiper motor (not US, JP)

Type	Bosch AHO 12V		
Speed (double strokes/min)	r/min	50-60	
Current consumption	A	0.75 - 1.5	
Current consumption, motor locked (e.g. wiper blades frozen to glass)	A	4.0 - 5.5	

### Heated front seats

Rating of heating elements	W	approx. 86
----------------------------	---	------------

### Rear window heater

Rating at 12 V	W	$215 \pm 25$
----------------	---	--------------

## Special tools

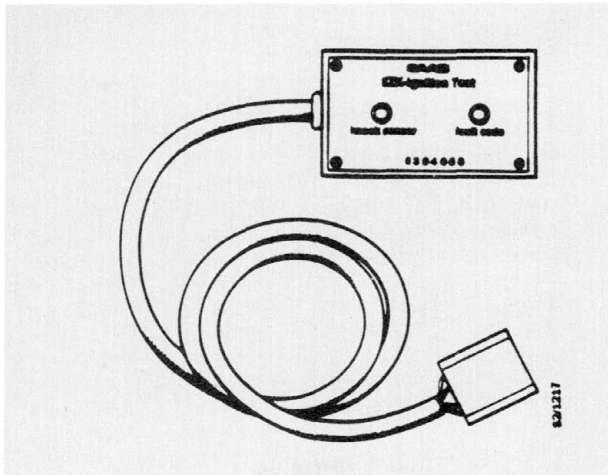

83 94 058 EZK test unit for checking and fault-tracing in the EZK ignition system.

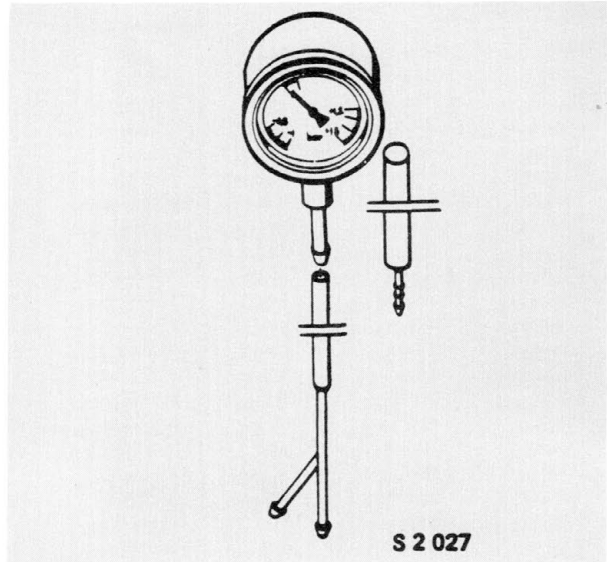

83 93 514 Equipment for measuring the boost pressure on the Turbo APC, and for testing components

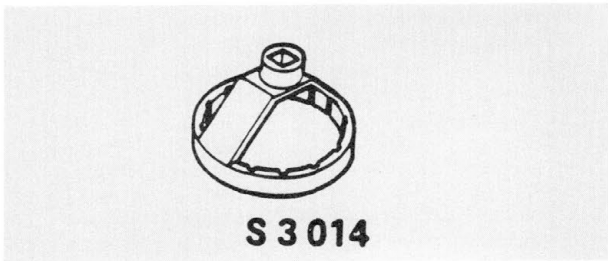

83 93 365 Spanner for fuel level transmitter

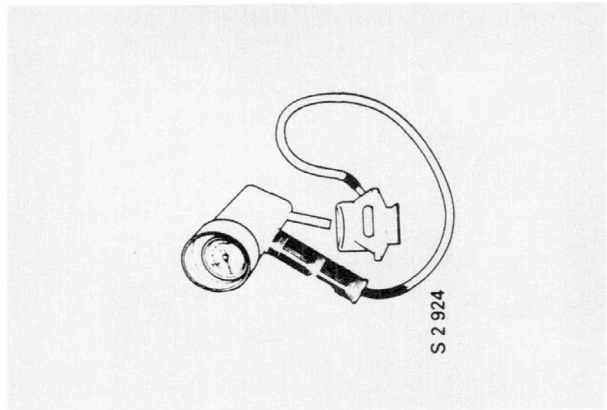

83 93 985 Belt-tension meter

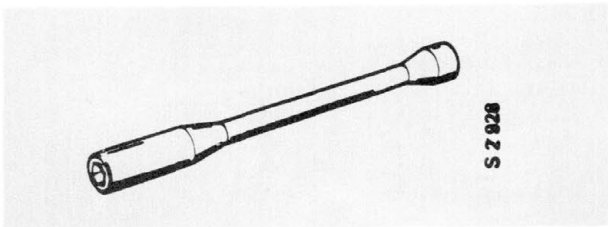

83 93 902 Spark plug socket, NV 16, 3/8" drive

# Battery

To remove . . . . .	311-1	Testing . . . . .	311-3
Battery care . . . . .	311-3	Charging . . . . .	311-4

The Saab 9000 is fitted with a sealed-for-life, 12 V battery, with a capacity of 62 Ah.

The battery is located on the left-hand side in the engine compartment and its negative terminal is connected to earth (negative-earth system).

The sealed-for-life battery works in the same way as a conventional battery and also contains an electrolyte consisting of diluted sulphuric acid. The battery must therefore always be kept upright.

The battery has a number of small vent holes, although much less gas is formed in this battery than in a conventional battery. Since the battery does not normally lose water, topping-up is not necessary and there are therefore no cell caps. Sealed-for-life batteries hold their charge longer than conventional batteries.

## To remove

- 1 Disconnect the negative (-) battery cable first, followed by the positive (+) cable.

### N.B.

**Never** disconnect the battery when the engine is running, since serious damage to the alternator may result.

- 2 Release the screw and remove the bracket which holds the battery.



## 311-2 Battery

---

3 Lift the battery out of the car.

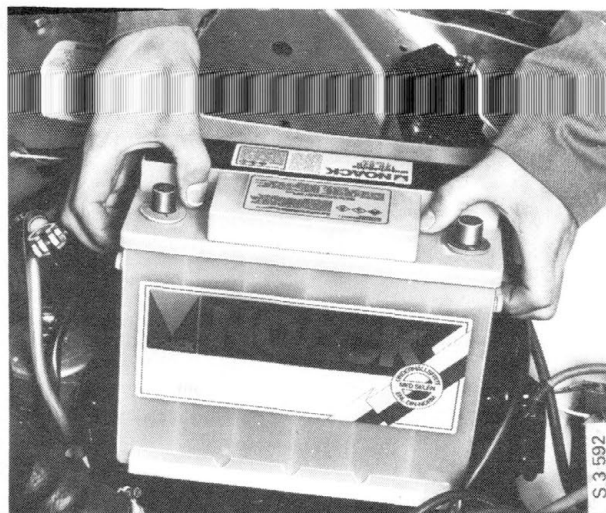

### To fit

Refit in the reverse order.

When refitting the battery, make sure that the external surfaces, terminal posts, pinch-bolts and clamps are clean. Lubricate the pinch-bolts and clamps with acid-free petroleum jelly.

### Caution

Never reverse the polarity of the electrical system by fitting the battery cables to the wrong terminals. If the cables are wrongly connected for only an instant, this is sufficient to damage the rectifier in the alternator. Always connect the red, positive (+) cable to the positive (+) terminal of the battery and the blue, negative (-) cable to the negative (-) terminal. When connecting an external battery to the car battery, connect the positive pole to the positive pole and the negative pole to earth (**not** to the negative pole). **Never** connect or disconnect the battery when the engine is running. For fast charging of the battery, disconnect both cables.

## Battery care

Since the level of charge in the battery is critical to starting of the engine, it is important to check and look after the battery regularly. This is particularly important in winter, when the load on the battery is higher and its capacity is reduced by the low ambient temperatures. A poorly charged battery may also freeze and be damaged in very cold weather.

## Testing

The capacity and level of charge of the battery can be tested by connecting a load (equivalent to that on starting) to the battery for 15 seconds and measuring the voltage.

Use a battery tester with load resistor for this purpose.

Test procedure:

Apply a load of about 200 A to the battery for 15 seconds, during which time the voltage should not drop below 9.6 V at a battery temperature of 27°C (80°F). The following table gives the corresponding voltages at lower temperatures.

<i>Battery temperature</i>	<i>Minimum voltage</i>
27°C (80°F)	9.6 V
16°C (60°F)	9.5 V
4°C (40°F)	9.3 V
-7°C (20°F)	8.9 V
-18°C (0°F)	8.5 V

If the voltage is lower, the battery is either poorly charged or has insufficient capacity.

## Charging

The battery can normally be recharged by means of a conventional battery charger. For fast charging, the charging current must not exceed 50 A.

If the battery is almost fully discharged, e.g. because an item of electrical equipment has been left switched on for a relatively long time, a low initial charge is required to start the chemical process in the battery. In such cases, charge the battery at 3 A (5 A max.) for 24 hours or until the charging current has fallen to its lowest stable value. The voltage on charging should not exceed 16 V, since a rapid loss of water would result.

In such cases, a battery charger delivering a pulsating charging current should preferably be used.

If the battery is found to be in good condition, poor performance may be due to abnormally heavy power consumption (e.g. if a power-consuming unit has been left switched on) or to a fault in the electrical system or charging system of the car.

Use the fault-tracing chart to find out why the battery is not performing properly.

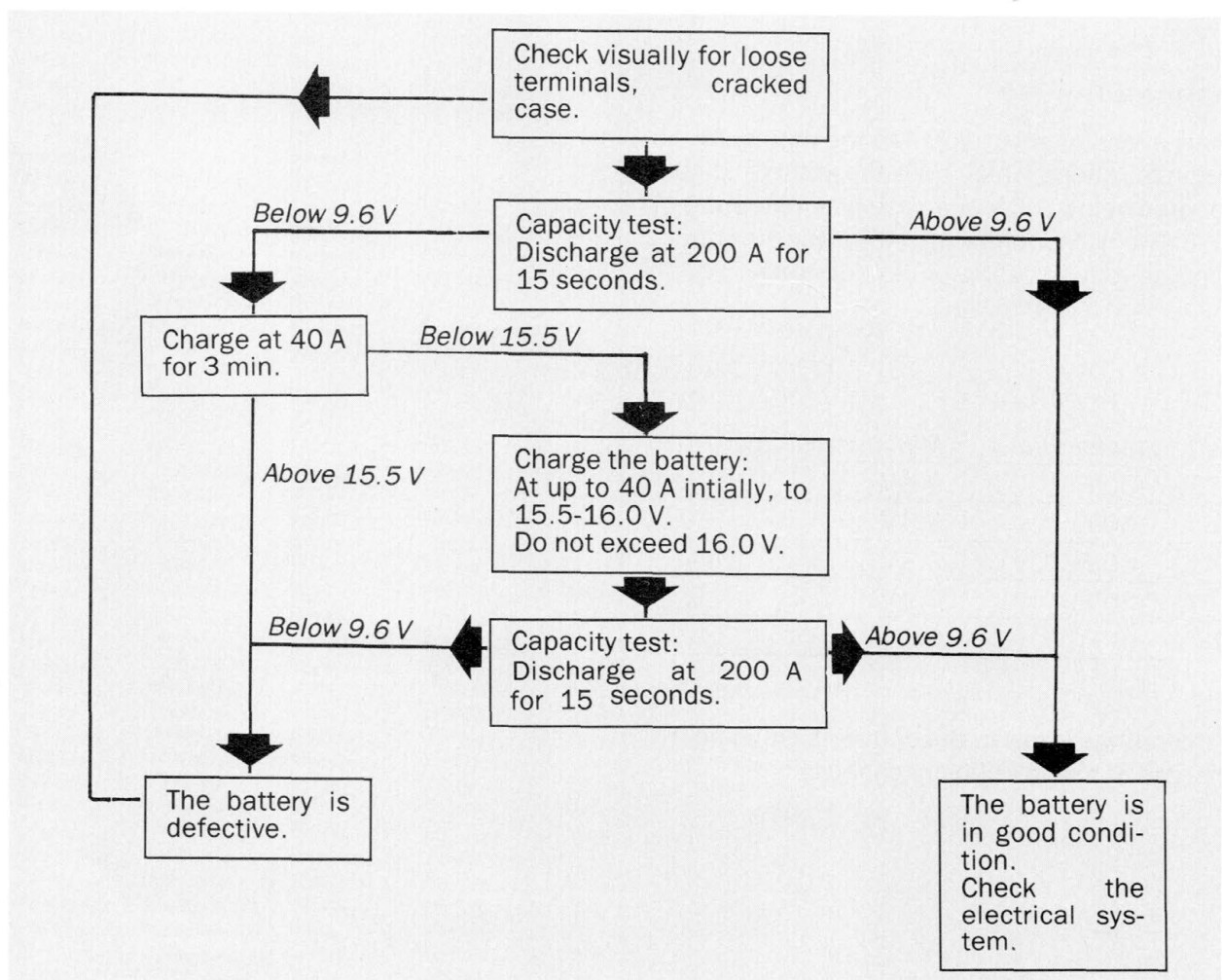

Fault-tracing chart



# Alternator

Principle of operation . . . . .	321-2	To assemble . . . . .	321-12
Internal circuitry . . . . .	321-3	Brushes . . . . .	321-16
Alternator care . . . . .	321-4	Testing . . . . .	321-17
Adjusting the belt tension . . . . .	321-4	Checking and testing of components .	321-18
To remove . . . . .	321-5	Fault-tracing chart . . . . .	321-21
To dismantle . . . . .	321-7		

The alternator has an external voltage regulator.

The alternator is driven by a Poly-V belt from the crankshaft pulley. Access to the alternator for servicing or removal can be gained by removing the front section of the right-hand wing liner.

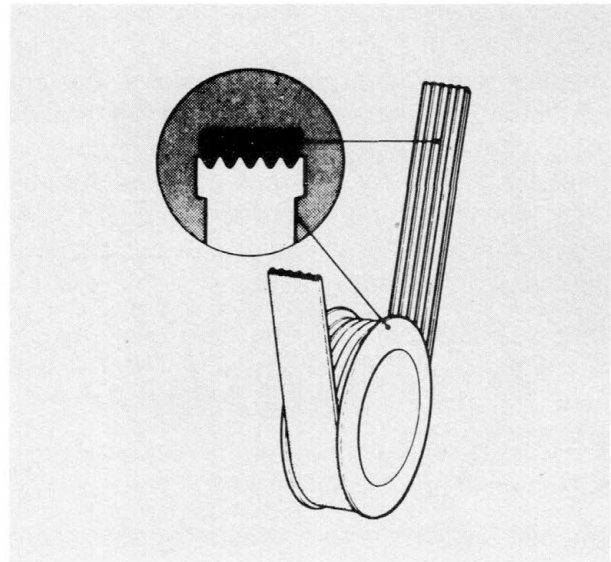

The pulley is equipped with vanes to dissipate the heat generated in the alternator. When the pulley is rotating, the vanes draw air through the alternator to provide the necessary cooling.

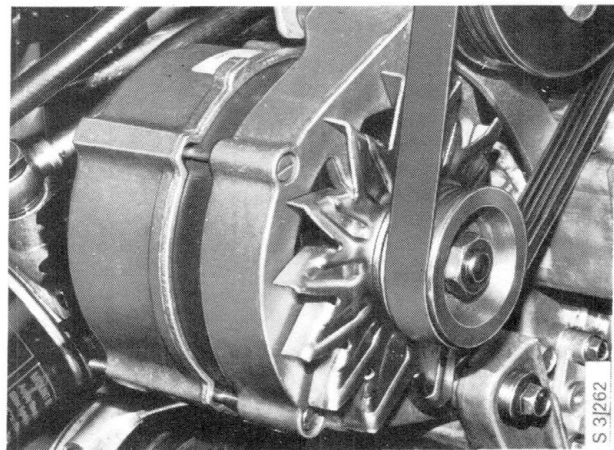

# Principle of operation

When the ignition is switched on, the circuit will be closed from the ignition switch via the warning lamp to terminal D+ on the alternator. Current will then flow through the rotor winding and to earth through the voltage regulator.

Current flowing through the rotor generates a magnetic field around the rotor. When the engine is started and the rotor starts to rotate, the magnetic field will also rotate, generating an alternating current in the stator windings. The alternating current is rectified in the rectifier diodes, and the direct current (d.c.) will be supplied to the battery via terminal B+. The current from the stator windings also flows through the excitation diodes to the voltage regulator, where it is used for controlling the output voltage. When the voltage has risen to about 14 V or above, the regulator will reduce the current flowing through the rotor winding.

This weakens the magnetic field and thus reduces the current generated in the stator windings.

The voltage regulator thus limits the voltage to a maximum of approximately 14 V.

The warning lamp is also affected by the voltage supplied by the stator windings via terminal D+ on the regulator, so that when the voltage on both sides of the warning lamp is the same, the lamp will not be alight. The lamp therefore indicates whether the alternator is charging.

No current limiting relay is required, since the alternator limits the current itself. When the alternator is running at high speed, the frequency of the induced alternating current will also be high, and when the output current has reached a given value, the resulting resistance (impedance) will be of such magnitude that any further current increase would be impossible.

You may:

- never** earth the excitation terminals of the alternator or regulator or the interconnecting cable.
- never** disconnect the regulator or battery while the alternator is running.
- never** remove the alternator while the battery is connected.
- never** run the alternator if the regulator is not connected.
- never** test the alternator and regulator assemblies in the car or on a test bench unless the battery is connected.
- never** reverse the polarity of the battery, as this may result in serious damage to the alternator.

Alternators should be overhauled only by specialist workshops. It is vitally important that they are dismantled and tested correctly, as seemingly minor errors may lead to serious damage.

### CAUTION

To avoid damage to the diodes, disconnect the negative (-) battery cable and all alternator connections before carrying out any electric welding on the car.

## Internal circuitry

The alternator, which is internally ventilated, has a 12-pole rotor, 12 silicon diodes for rectification and an additional two for the "third circuit".

An excitation diode is connected to each of the three stator windings. The excitation diodes are interconnected at terminal D+.

The stator windings form three phases and are star-connected  $\Delta$ .

The 14 rectifier diodes are connected in the form of a bridge circuit, i.e. seven diodes are connected for normal polarity (anode to the terminal) and seven for reversed polarity (anode to earth).

The diode holder is either insulated from the stator frame (earth) or directly earthed, according to the polarity. The excitation winding is mounted in the rotor which has claw-type poles, with alternate claws acting as north pole and south pole.

The excitation current is supplied to the rotor coil via brushes and slip rings on the rotor.

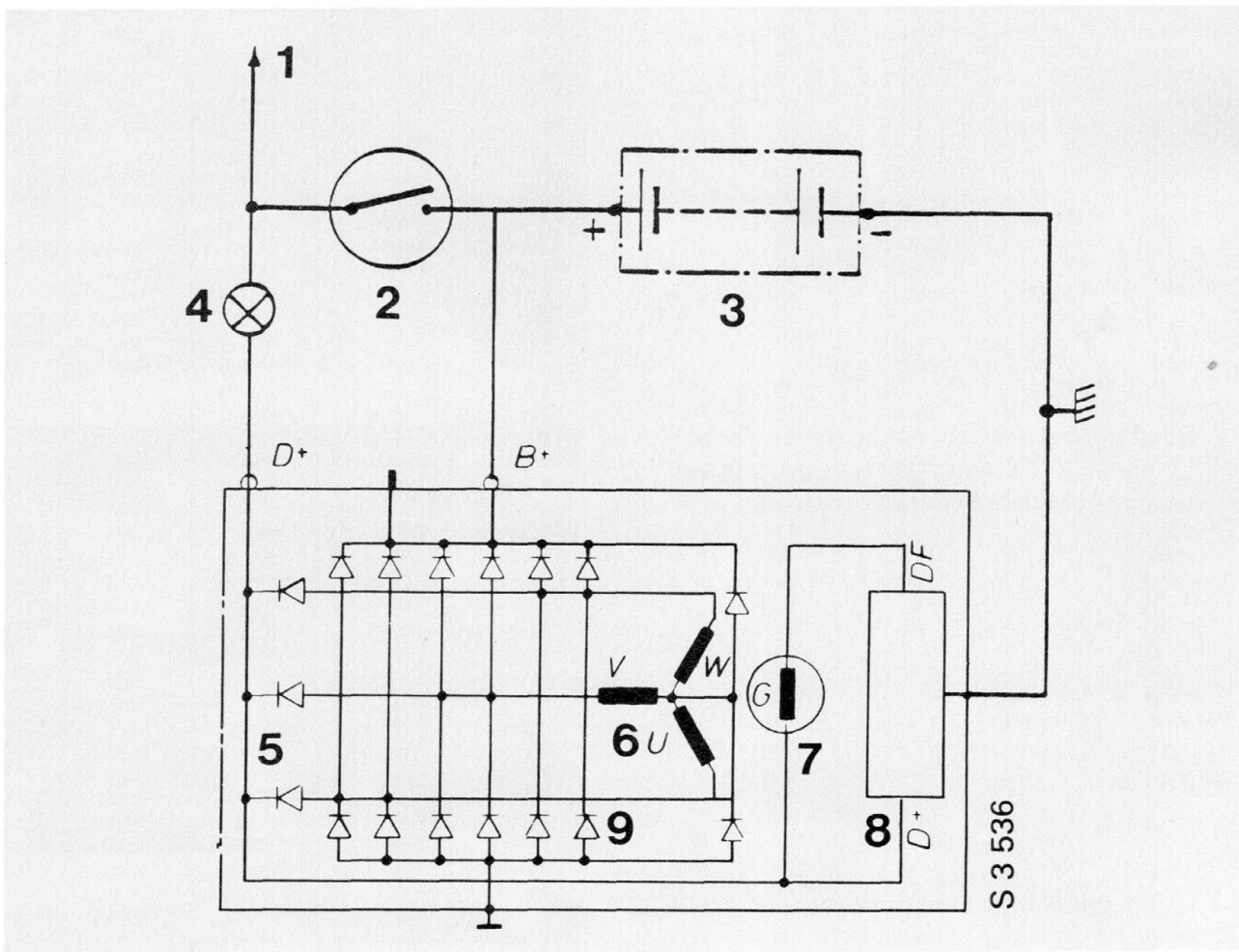

Wiring diagram for the Bosch 80 A alternator

- 1 To power consumers
- 2 Ignition switch
- 3 Battery
- 4 Warning lamp
- 5 Excitation rectifier
- 6 Stator windings
- 7 Rotor winding
- 8 Voltage regulator
- 9 Rectifier

S 3 536

### Alternator care

The alternator has fully enclosed ball bearings which require lubrication only if removed in conjunction with other repairs.

The alternator is driven by a Poly-V belt from the crankshaft pulley, and the belt must be correctly tensioned to avoid slipping or unnecessary overloading of the bearings.

### Adjusting the belt tension

- 1 Fit the belt-tension meter.

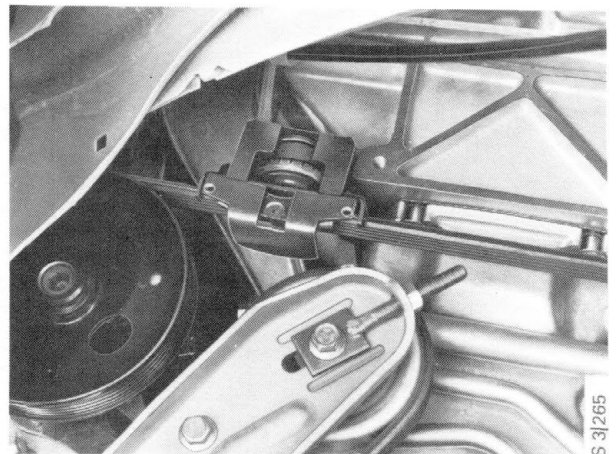

- 2 Read the belt tension on the meter. For particulars of the correct belt tension, see section 023 "Technical data".

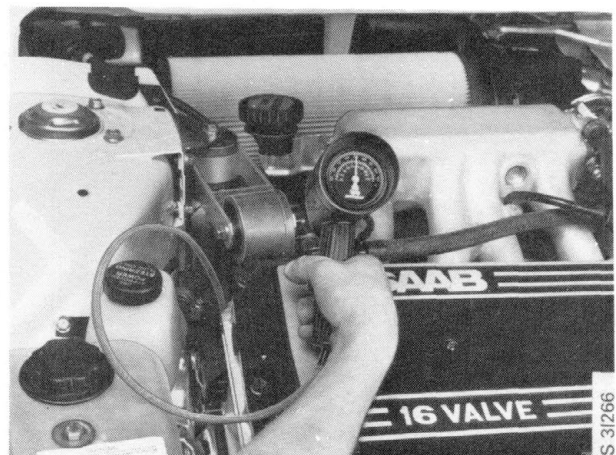

- 3 Adjust the belt tension as necessary.

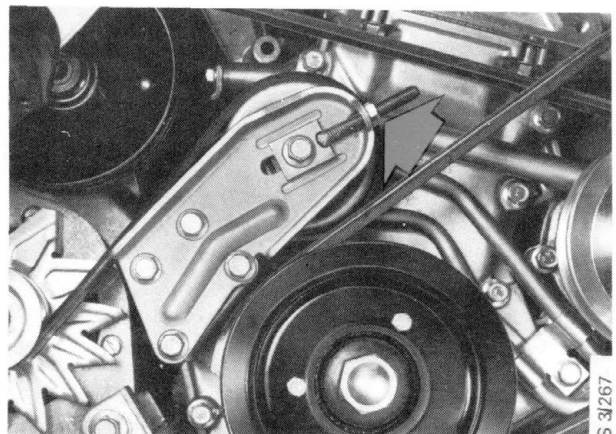

## To remove

- 1 Disconnect the negative (-) battery cable.

### N.B.

**Never** disconnect the battery when the engine is running, since serious damage to the alternator may result.

- 2 Jack up the front of the car, support it on axle stands and remove the right-hand front wheel.
- 3 Remove the front section of the right-hand wing liner.
- 4 Slacken the alternator belt and prise it off the alternator pulley.

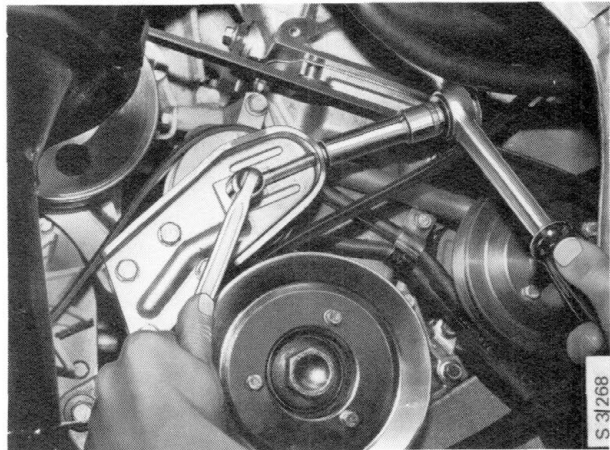

- 5 Disconnect the electrical connections from the rear of the alternator.

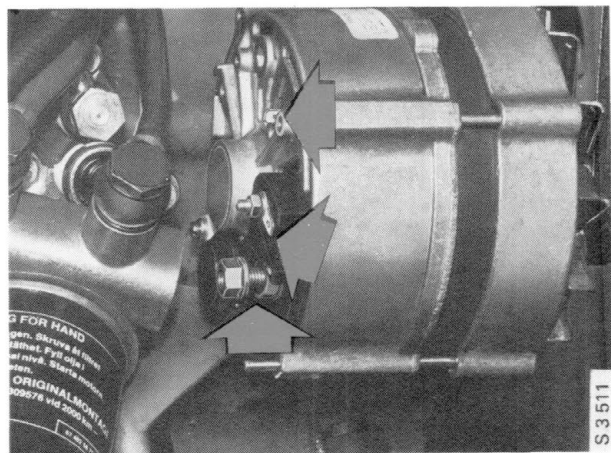

## 321-6 Alternator

- 6 Slacken the two securing bolts for the alternator.

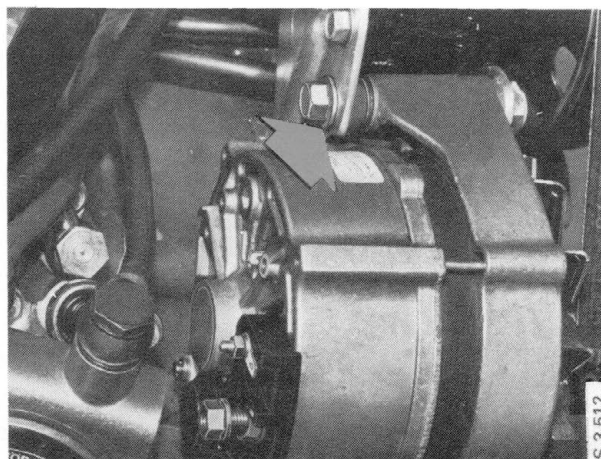
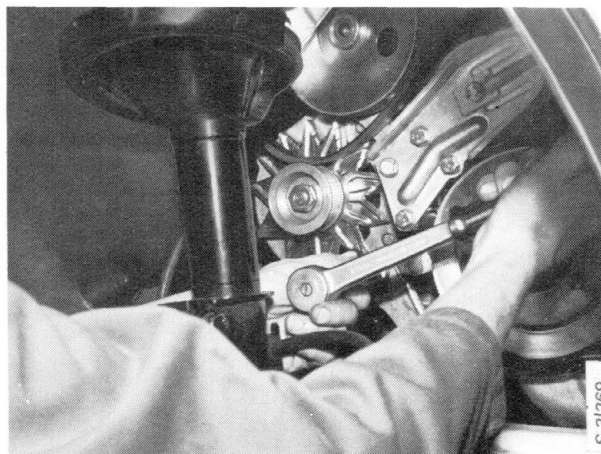

- 7 Use a screwdriver to lever the alternator to the left.

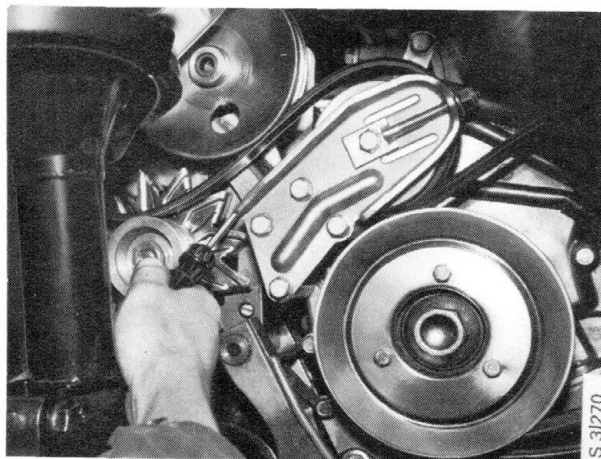

- 8 Pull the alternator forward.

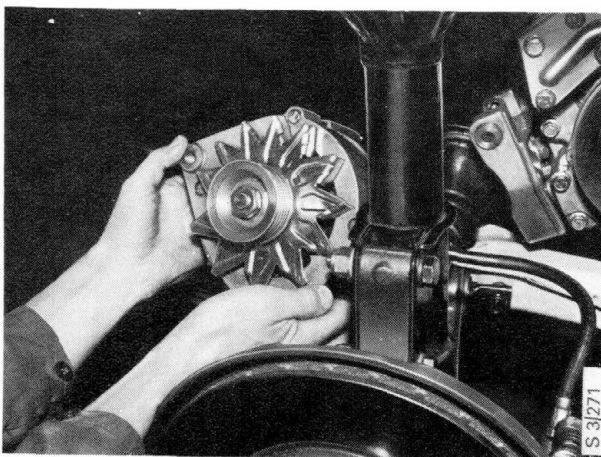

**To fit**

Refit in the reverse order

The belt tension must be adjusted after the alternator has been refitted.

**To dismantle (alternator removed from the car)**

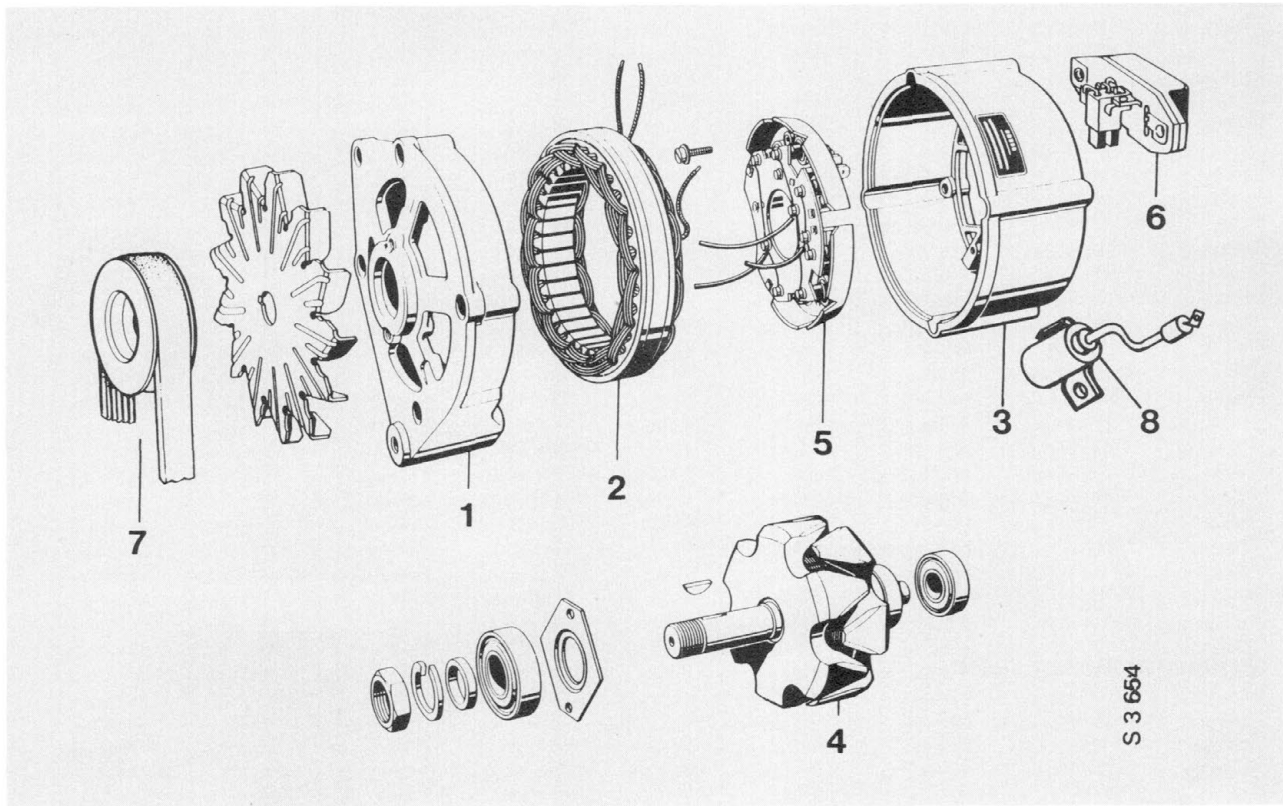

*The Bosch 80 A alternator*

- 1 Drive end bracket
- 2 Stator
- 3 Slip-ring end bracket
- 4 Rotor
- 5 Rectifier unit
- 6 Voltage regulator and brush-holders
- 7 Pulley
- 8 Interference suppressor (capacitor)

## 321-8 Alternator

- 1 Remove the pulley nut, using a nut runner with a 22 mm socket, and remove the pulley.

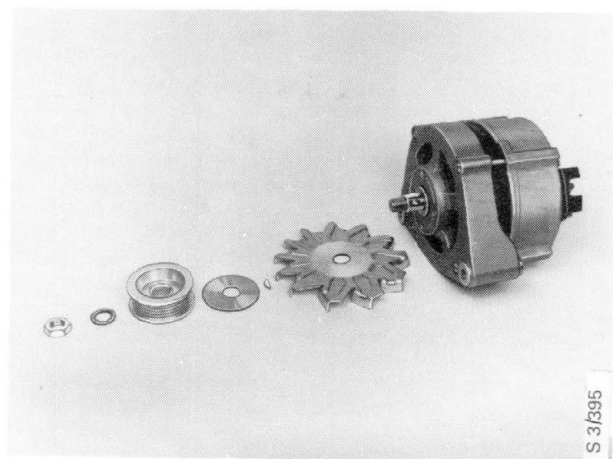
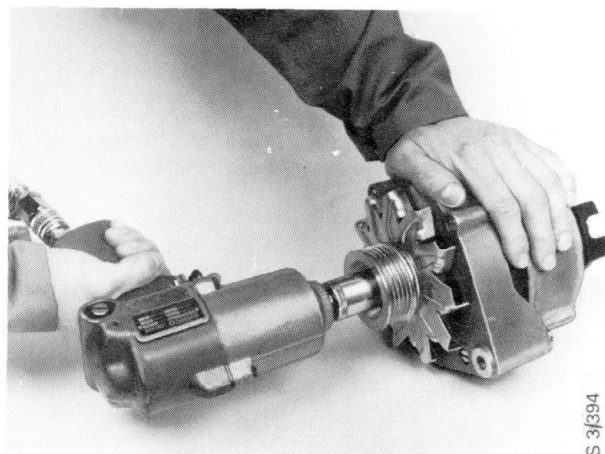

- 2 Remove the regulator.

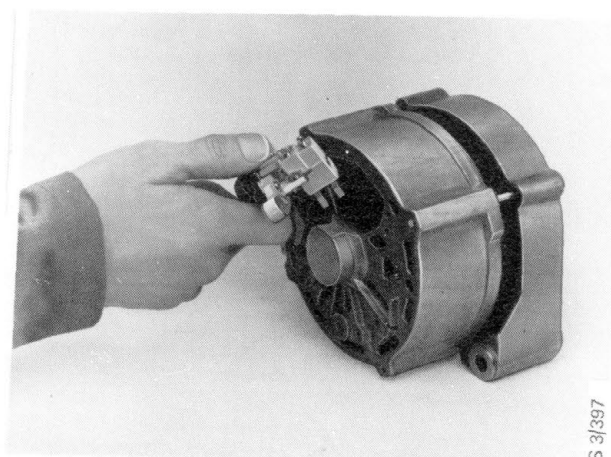
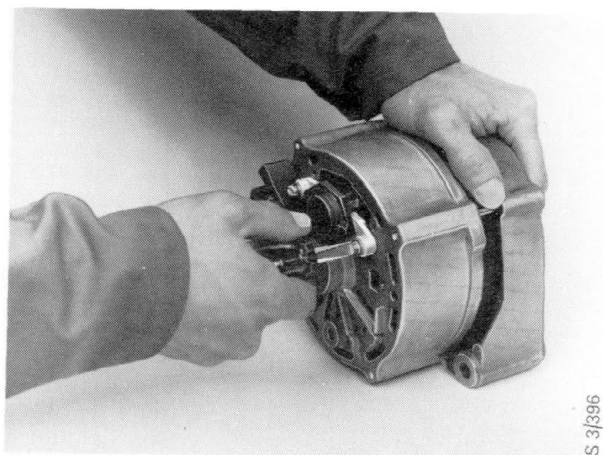



- 3 Mark the positions of the drive end and slip-ring end brackets relative to the stator ring.

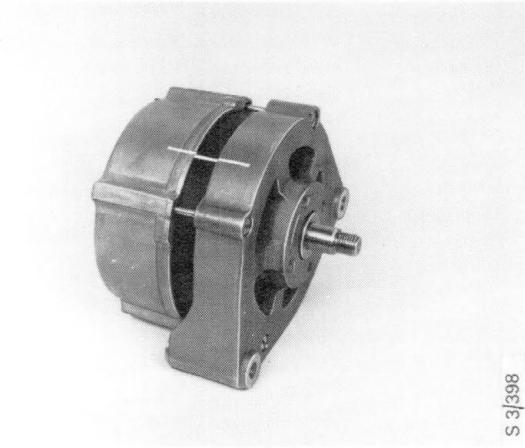

- 4 Separate the stator and slip-ring end bracket from the drive end bracket and rotor.

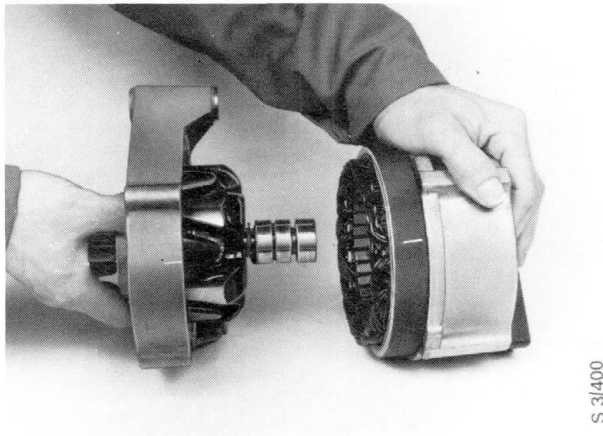
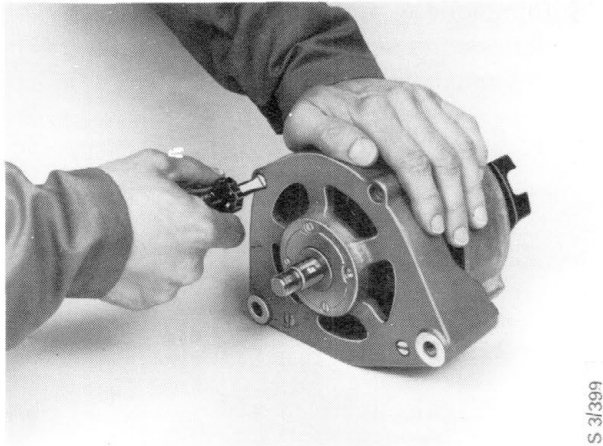

- 5 Remove the insulation block.

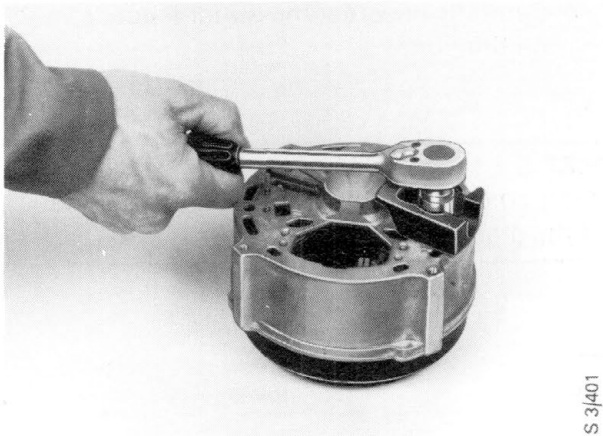

## 321-10 Alternator

---

- 6 Remove the three rectifier unit retaining screws and separate the unit from the slip-ring end bracket.

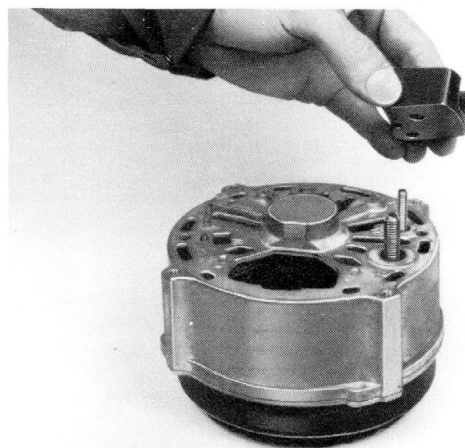

S 3/402



S 3/403

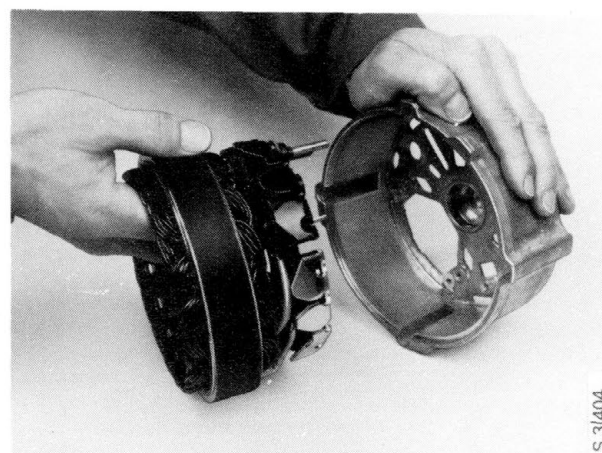

S 3/404

- 7 Carefully unsolder the stator leads from the rectifier unit.

---

**N.B.**

Work quickly to avoid unnecessary overheating of the diodes.

---

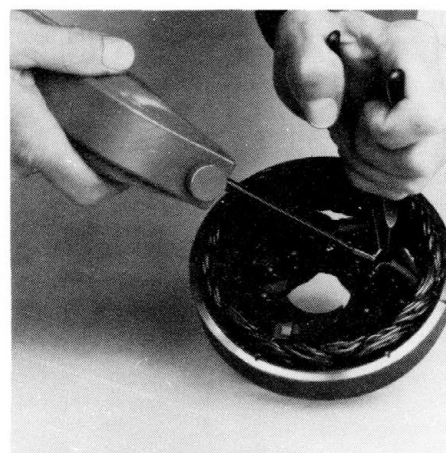

S 3 405

- 8 Place the drive end bracket on a suitable surface and press the rotor out carefully.

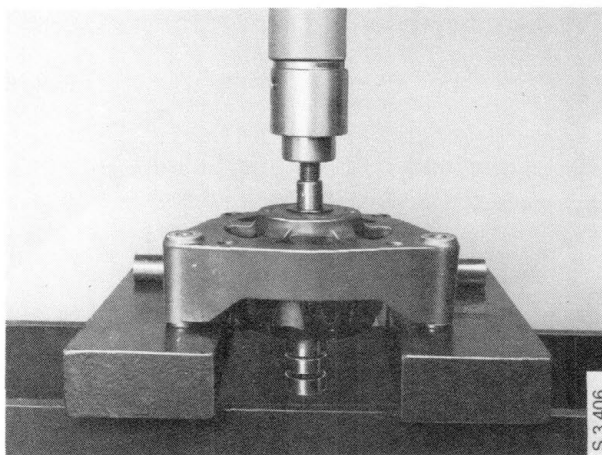

**N.B.**

To avoid damage, prevent the rotor from falling as it comes free of the bracket.

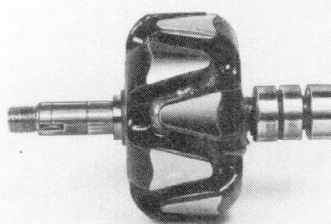

- 9 Remove the screws for the bearing retaining plate and remove the plate.

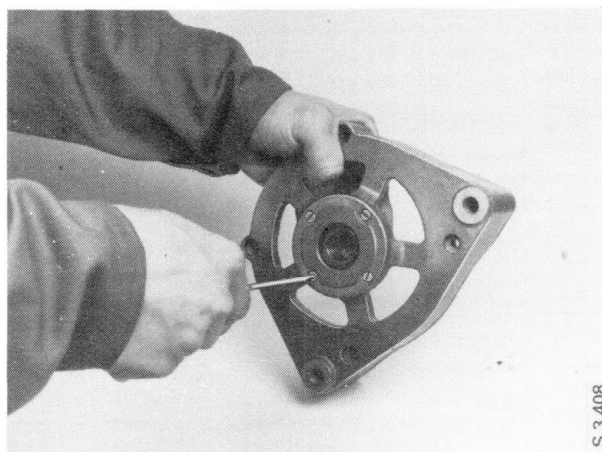

- 10 Use an extractor to remove the ball bearing at the slip-ring end.

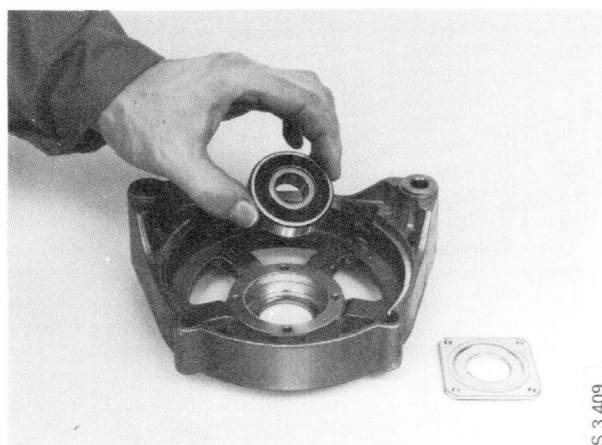

### To assemble

- 1 Pack the bearings with Bosch Ft1v34 grease.
- 2 Fit the ball bearing and bearing retaining plate to the drive end bracket.

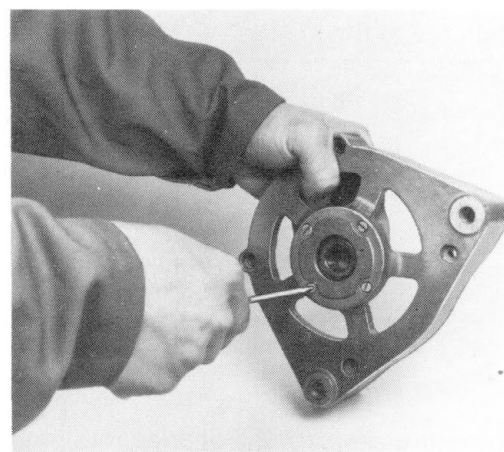

- 3 Press the ball bearing onto the slip-ring end of the rotor, with the enclosed side towards the slip rings.



- 4 Press the drive end bracket onto the rotor.

5 Solder the stator leads to the rectifier unit.

---

**N.B.**

Work quickly to avoid unnecessary overheating of the diodes.

---

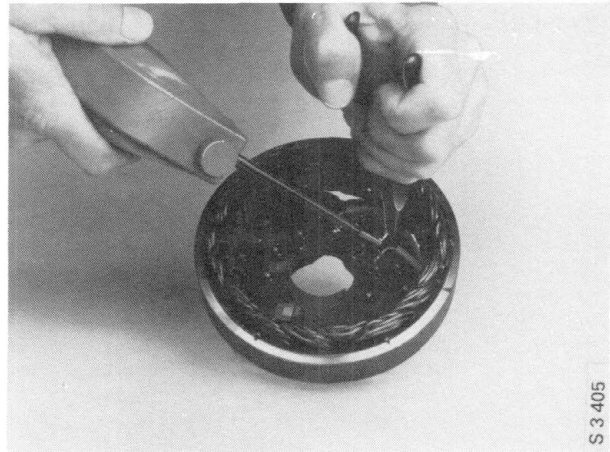

6 Fit the rectifier unit to the slip-ring end bracket.

---

**N.B.**

Remember to fit the insulating washers to the electrical terminal screws.

---

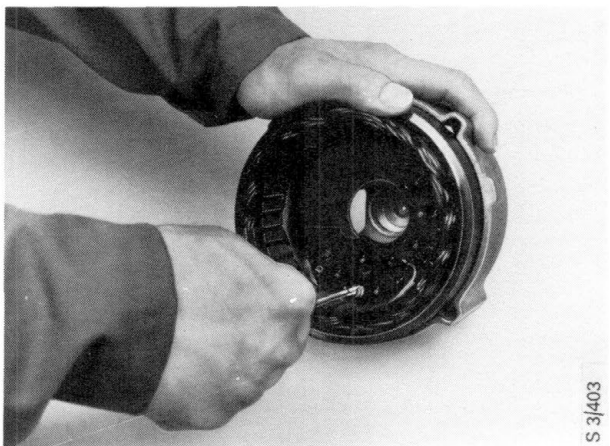
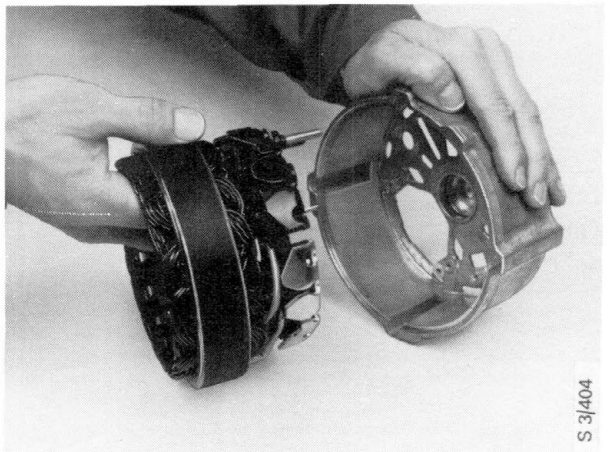
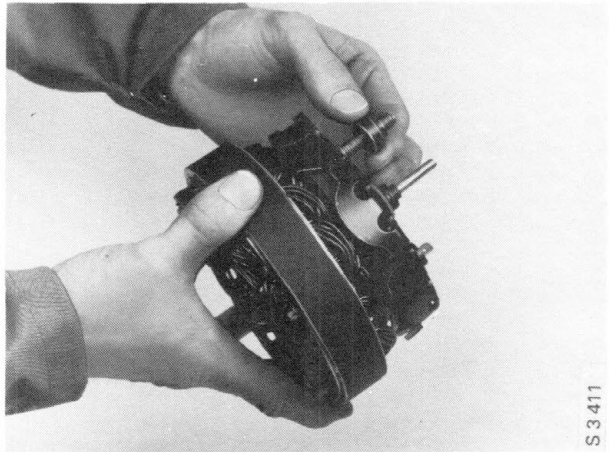

7 Fit the insulation block.

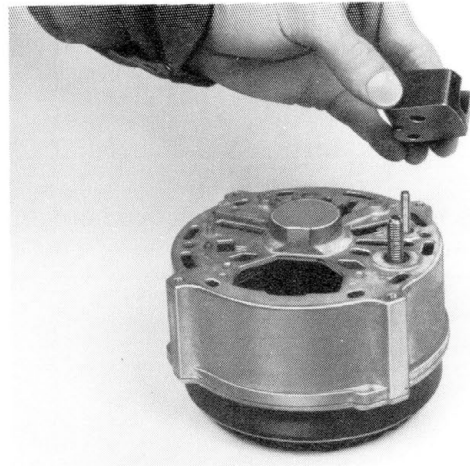

S 3/402

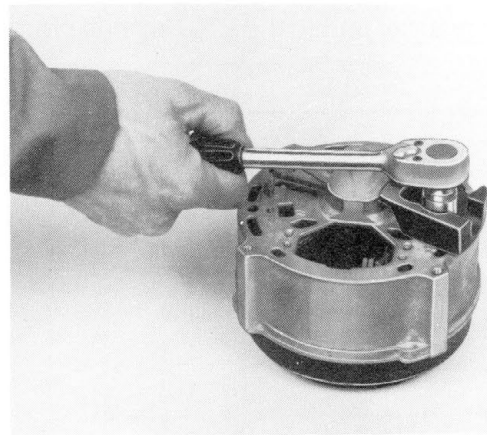

S 3/401

8 Fit the drive end bracket and rotor to the slipping end bracket and stator.

---

**N.B.**

Make sure that the marks made before dismantling are lined up.

---

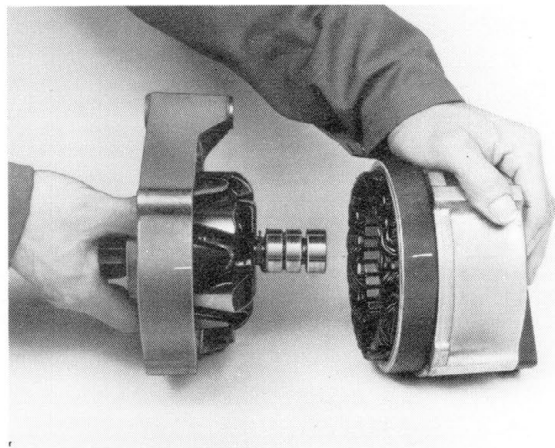

S 3/400

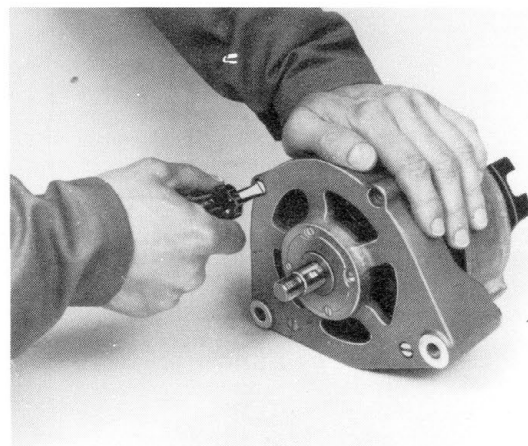

S 3/399

9 Fit the regulator unit.

**N.B.**

Before fitting, make sure that the brushes project at least 5 mm (0.2 in) from the brush-holder.

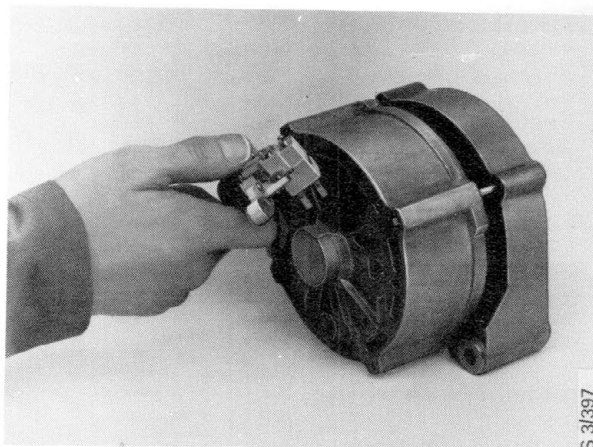

10 Fit the fan and pulley, complete with washers.

**Tightening torque:**

**34 - 39 Nm (25 - 29 lbf ft)**

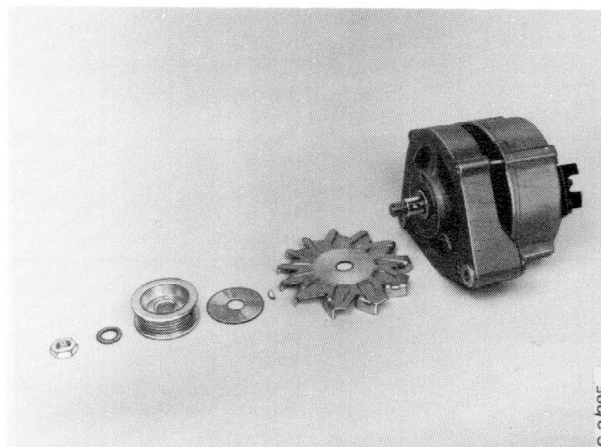

## Brushes

The alternator brush-holder is integrated with the voltage regulator unit. The brushes can be checked when the regulator unit has been removed from the alternator. The brushes should project at least 5 mm (0.2 in) from the brush-holder. If not, fit new brushes.

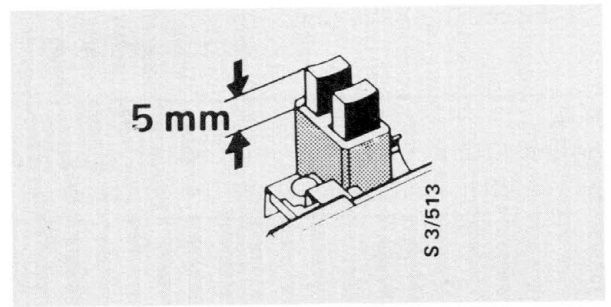

### To change the brushes

- 1 Remove the voltage regulator unit.
- 2 Carefully unsolder the brush lead from the brush-holder terminal, withdrawing the brush from the holder at the same time.

---

#### **N.B.**

Work quickly to avoid unnecessary overheating of the regulator.

---

- 3 Carefully remove any traces of solder from the brush-holder terminal.
- 4 Fit the new brush into the brush-holder, insert the brush lead into the brush-holder terminal and solder it.

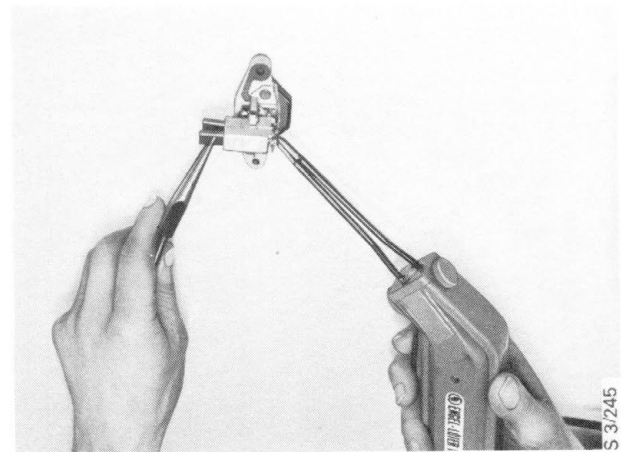
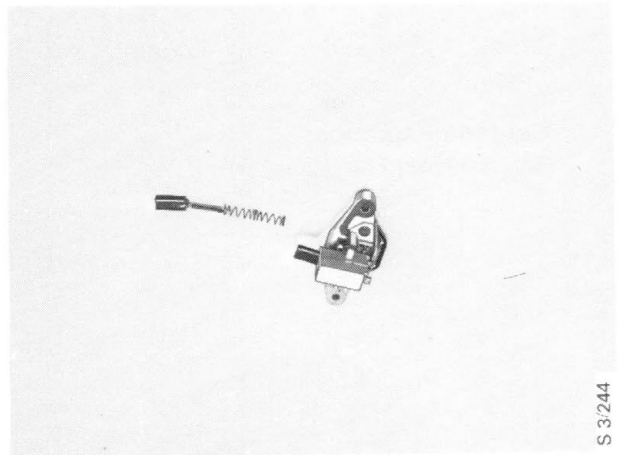



## Testing

Read this section carefully before carrying out any tests on the alternator or its components.

For testing the rectifiers, use only d.c. at a maximum voltage of 40 V. For insulation and short-circuit tests on the stator and rotor windings, use a 40 V/40 W a.c. test lamp (do not use 110 V or 220 V mains supply, as this may damage the rectifiers). When measuring the charging current, never disconnect the battery leads while the engine is running.

When soldering or unsoldering the diode terminals, use flat-nose pliers to hold the diode lead, since the pliers will help to dissipate the heat from the semiconductors, which are highly sensitive to heat (work quickly with a hot soldering iron).

Avoid bending the leads or applying pressure to them at the point where they enter the diode case.

Before doing any work on the alternator, either in the car or on the test bench, always disconnect the battery first.

---

### N.B.

The alternator should be at working temperature (60°C/140°F) during testing.

---

### Testing the alternator on a test bench.

On the test bench, the alternator may only be driven by means of its drive pulley. See Section 023 "Technical data" for the reduction ratio between the engine and alternator.

All cables must be connected by means of spade terminals or plug-in connectors. This also applies to the battery - never use makeshift connections.

During testing, a 12 V battery must be connected in parallel across the alternator. The battery will serve as a buffer and will smooth out the voltage peaks occurring when loads are switched on or off. If such peaks should exceed the permissible voltage limits, the rectifying function of the diodes will be destroyed. The maximum voltage for silicon diodes is approximately 100 V.

The alternator can be tested in most types of alternator test bench. However, suitable mountings and drives may have to be added in some cases.

### Caution

During testing, the alternator must be secured by means of its normal mountings. Never use clamps or the like.

### Excitation

Unlike a d.c. generator, an alternator is not self-exciting after it has been idle for some time. A 12 V warning lamp with a rating of at least 2 W must therefore be connected between terminals D+ and B+ (see the wiring diagram). The initial excitation current for the rotor field winding flows across the warning lamp, and through alternator terminal D+, voltage regulator terminal D+, the closed regulator contacts and terminal DF. The rating of the warning lamp must therefore be at least as high as specified above. Self-excitation will start as soon as the alternator voltage has opened the excitation diodes, i.e. at 1 - 2 V. The voltage will then rise rapidly and the voltage differential across the warning lamp will steadily decrease. The lamp will remain alight until the alternator output voltage is equal to the battery voltage.

### Checking the charging capacity

The charging voltage and charging current can be measured with the alternator in the car or mounted on a test bench.

Measure the voltage by means of a voltmeter connected between terminal B+ and earth on the alternator.

Measure the current by means of an ammeter connected in series with output cable from alternator terminal B+.

## Test values

Connect the battery and apply an electrical load to the alternator. Run the alternator at the specified rated speed, and the alternator current should then be 2/3 of its maximum current:

Bosch 80A 54 A at 1900 r/min

## Insulation test on assembled alternator

After the alternator has been dismantled and re-assembled, check the insulation between terminal B+ and earth by means of an insulation tester.

## Checking and inspection of dismantled components

### Rotor

To measure the resistance.

Use an ohmmeter ( $\Omega \times 1$  range) to measure the resistance of the winding between the slip rings.

The resistance reading should be:

Bosch 80A 2.5 - 3.1 ohm

A low resistance indicates short-circuit in the rotor winding. A high resistance ( $\infty$ ) indicates open-circuit in the rotor winding.

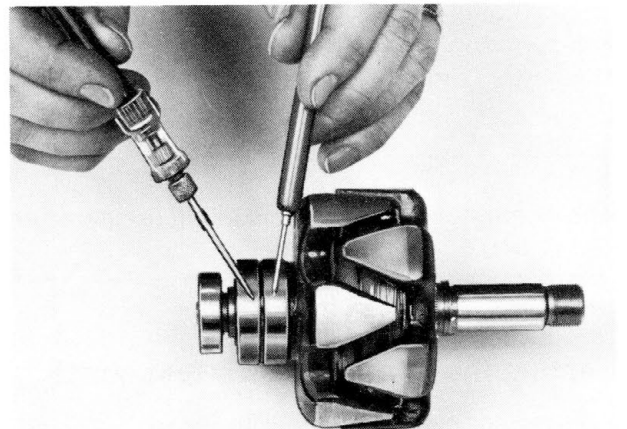

S 4021

### Short-circuit test

Use an ohmmeter ( $\Omega \times 1000$  range) to measure the resistance between one of the slip rings and the alternator stator frame.

The resistance should be high ( $\infty$ ).

A low resistance indicates short-circuit between the rotor winding and earth. A 40 V/40 W a.c. test lamp can also be used for the short-circuit test.

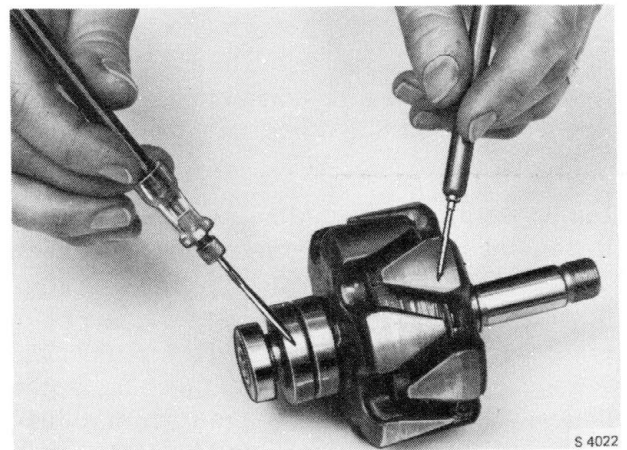

S 4022

**Slip rings**

Check the surface of the slip rings for grease, dirt and scoring. Clean them with trichlorethylene. Avoid polishing the surface of the slip rings, as a highly polished surface provides poorer contact with the brushes.

The diameter of the slip rings should be 27.8 mm, +0/-1 mm (1.08 in, +0/-0.04 in).

The maximum permissible slip-ring ovality is 0.03 mm (0.001 in).

**Stator**

To measure the resistance

Use an ohmmeter ( $\Omega \times 1$  range) to measure the resistance of the stator windings (three readings).

The resistance readings should be:

Bosch 80A 0.10 ohm 10%

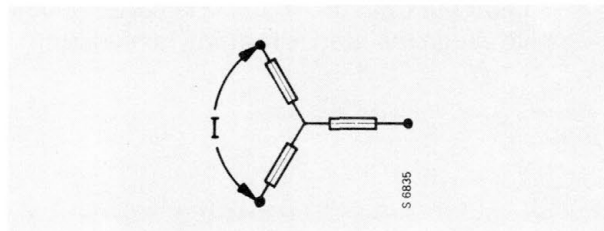
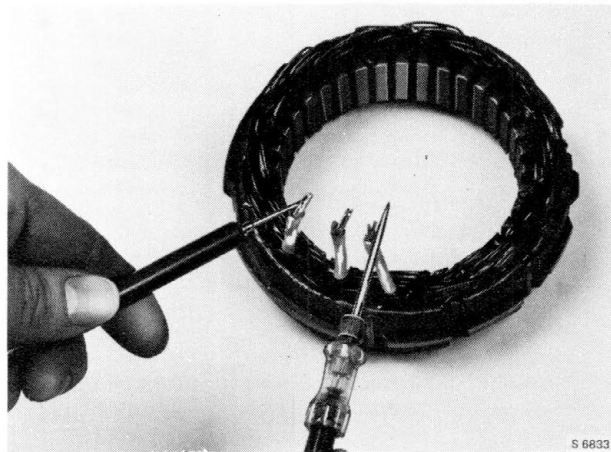

Bosch 80A

**Short-circuit test**

Use an ohmmeter ( $\Omega \times 1000$  range) to measure the resistance between the stator frame and each of the stator windings.

The resistance should be high ( $\infty$ ).

A low resistance indicates short-circuit between the rotor winding and earth. A 40 V/40 W a.c. test lamp can also be used for the short-circuit test.

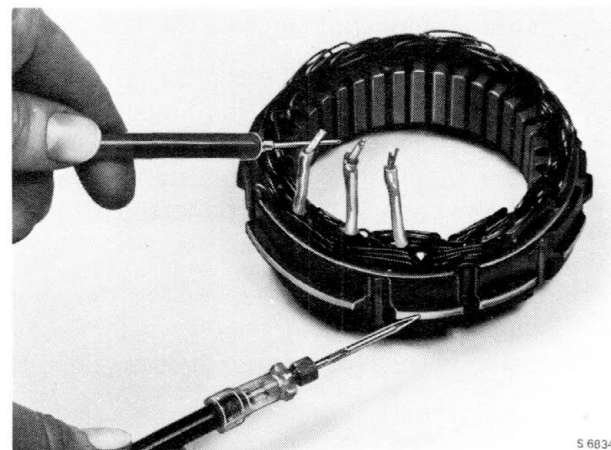

## Diodes (rectifier)

Use a test lamp (up to 40 V) or an ohmmeter to test the diodes for open-circuit or short-circuit.

### Positive rectifier diodes

Measure between terminal B+ and the stator terminal points.

The test lamp should be alight when its positive terminal (40 V max.) is connected to one of the stator terminal points, or the ohmmeter should give a low resistance reading when its positive lead is connected to one of the stator terminal points.

If the connections are reversed, the lamp should not light up, or the ohmmeter should give a high resistance reading (a few kohm).

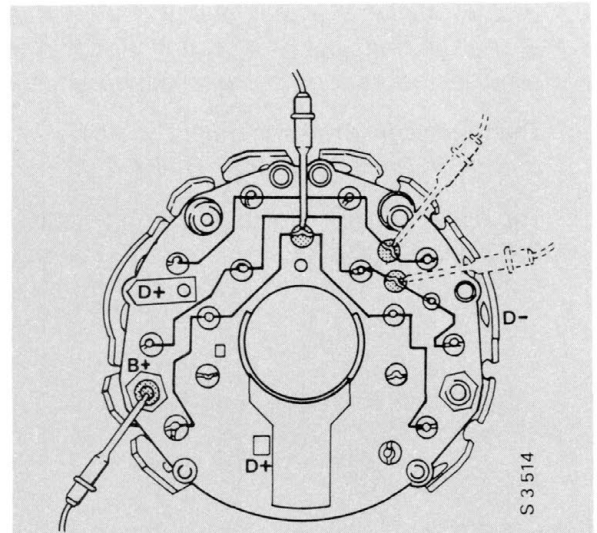

### Negative rectifier diodes

Measure between terminal D- and the stator terminal points.

The test lamp should be alight when its positive terminal (40 V max.) is connected to one of the stator terminal points, or the ohmmeter should give a low resistance reading when its positive lead is connected to D-.

If the connections are reversed, the lamp should not light up, or the ohmmeter should give a high resistance reading (a few kohm).

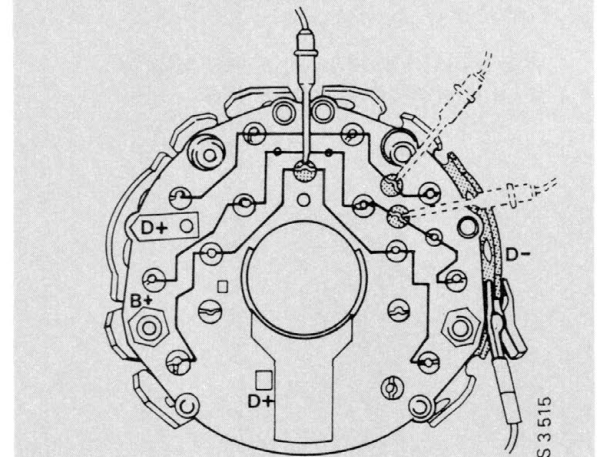

### Excitation diodes

Measure between terminal D+ and the stator terminal points.

The test lamp should be alight when its positive terminal (40 V max.) is connected to one of the stator terminal points, or the ohmmeter should give a low resistance reading when its positive lead is connected to one of the stator terminal points.

If the connections are reversed, the lamp should not light up, or the ohmmeter should give a high resistance reading (a few kohm).

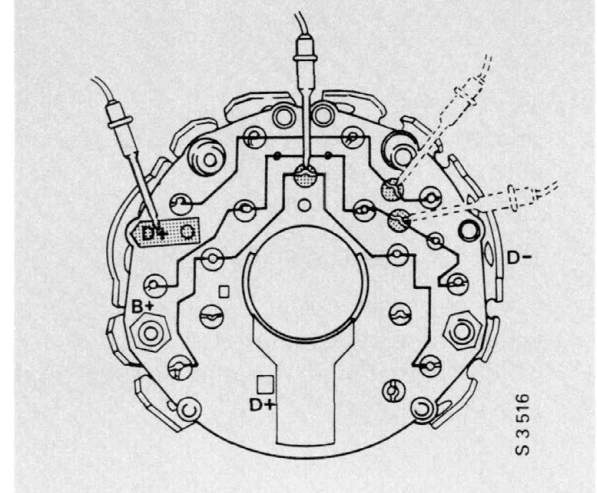

## Brush holder

Check that the brushes move freely in the holder.

Check the wear on the brushes: at least 5 mm (0.2 in) should project from the holder.

Check that the brushes are well insulated from each other. Measure the resistance between the brushes. The reading should be high ( $\infty$ ).

Check that the contact between each brush and the "-" or DF terminal is good.

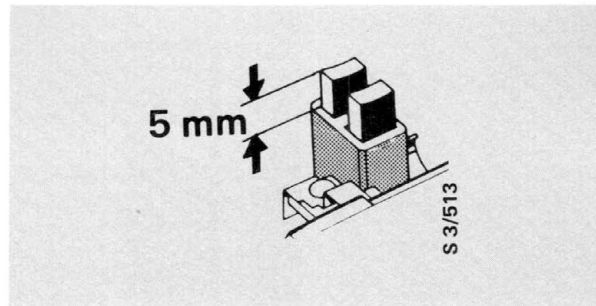

## Fault-tracing

Alternator not charging

- Alternator drive belt slack
- Charging circuit and/or earth circuit open
- Brushes defective
- Voltage regulator defective
- Diodes defective
- Excitation circuit open
- Rotor winding open-circuited
- Stator earthing

Insufficient or irregular output current

- Alternator drive belt slack
- Brushes defective
- Voltage regulator defective
- Rectifier diodes defective
- Rotor partially short-circuited
- Stator connection to earth broken or partial short-circuit.

Current too high

- Voltage regulator defective
- Poor contact between regulator and alternator.

Alternator noisy

- Alternator drive belt very worn
- Pulley incorrectly fitted
- Alternator mountings loose
- Alternator and crankshaft pulleys misaligned
- Bearings worn or defective
- Rectifier diode short-circuited

# Starter Motor

Principle of operation . . . . .	331-1	To dismantle . . . . .	331-4
Internal circuitry . . . . .	331-1	To assemble . . . . .	331-10
To remove . . . . .	331-3	Inspection . . . . .	331-22

The starter motor of the Saab 9000 is equipped with planetary gears.

Compared with conventional types, this starter motor is lighter, more compact and can run at a higher speed.

## Principle of operation

The starter motor turns the engine flywheel by means of a pinion which drives a ring gear. When the ignition switch is turned to the start position, a solenoid moves the axially movable pinion into engagement with the ring gear. The solenoid then closes the main contacts and current is supplied to the starter motor.

When the engine has started, the flywheel speed will gradually exceed that of the starter motor. This causes the free-wheel to disengage the starter pinion from its shaft, thus preventing overspeeding of the starter motor.

When the ignition key is released, the supply circuit to the solenoid will be opened and a spring will return the pinion to its rest position.

## Internal circuitry

Instead of a conventional housing with field windings, the Saab 9000 starter motor consists of a stator frame with six permanent magnets. This design reduces the electrical resistance and thus the starting resistance.

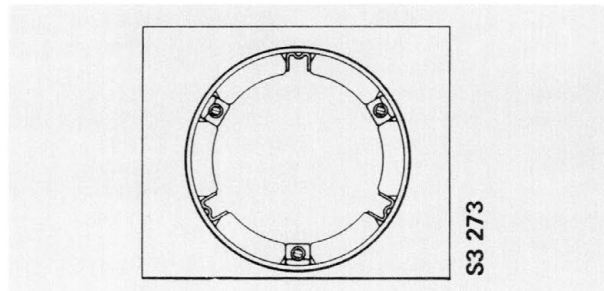

*Stator frame with six permanent magnets*

When the ignition key is turned to the start position, current will flow to terminal 50 and the solenoid will be energised.

When the solenoid is energised, the circuit to terminal 30 will be closed and the armature windings will be connected directly to the battery via the brushes.

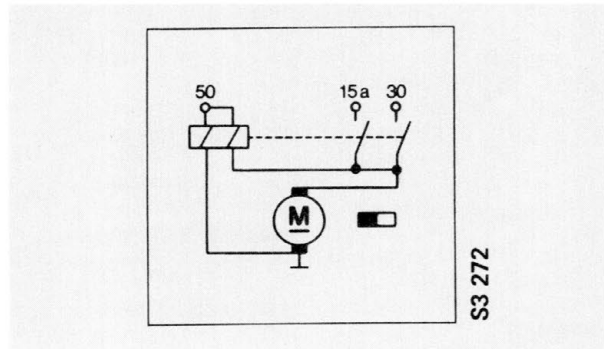

*Wiring diagram*

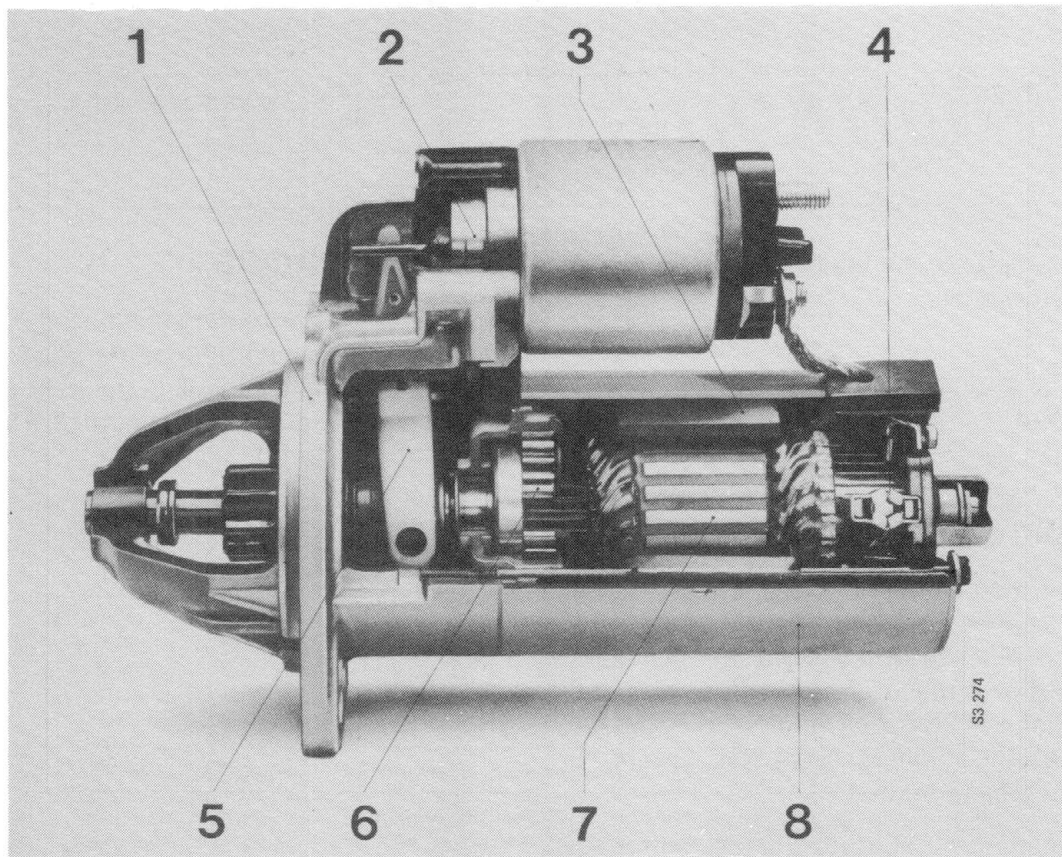

*Cut-away view of starter motor*

- |                           |                        |
|---------------------------|------------------------|
| 1 Pinion bracket assembly | 6 Planetary gear train |
| 2 Solenoid                | 7 Armature             |
| 3 Permanent magnets       | 8 Stator frame         |
| 4 Brush-holder assembly   |                        |
| 5 Pinion-engaging lever   |                        |

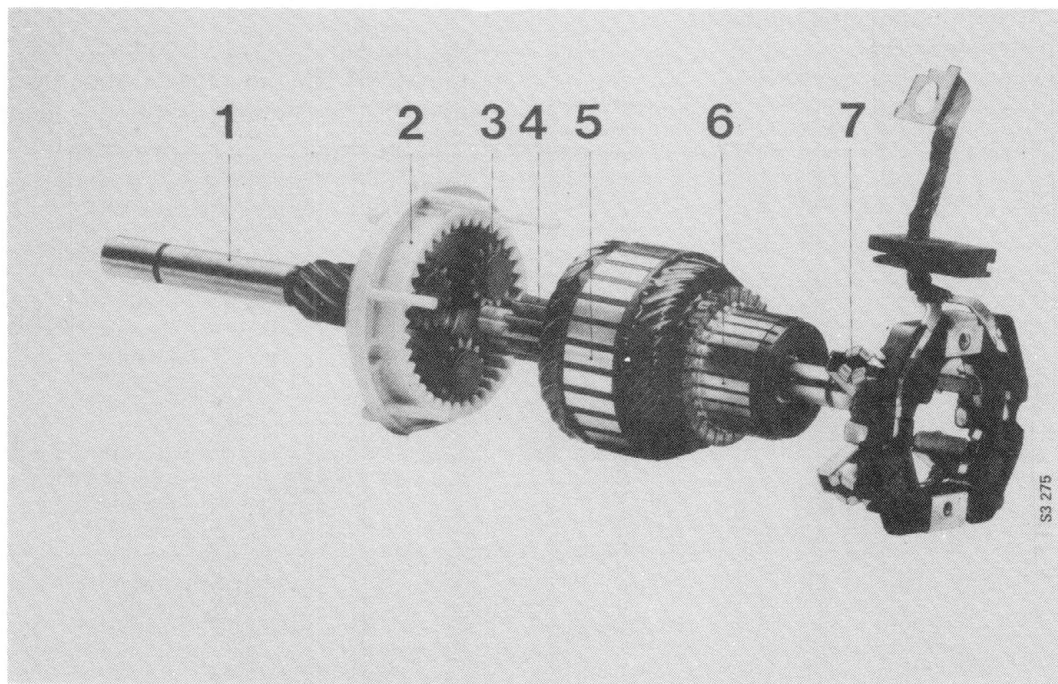

- |                                     |                         |
|-------------------------------------|-------------------------|
| 1 Pinion shaft                      | 5 Armature              |
| 2 Annulus                           | 6 Commutator            |
| 3 Planet gear                       | 7 Brush-holder assembly |
| 4 Armature shaft carrying sun wheel |                         |

## To remove

- 1 Disconnect the negative (-) battery cable.

---

### N.B.

**Never** disconnect the battery when the engine is running, since serious damage to the alternator may result.

---

- 2 Disconnect the electric cables from the starter motor.

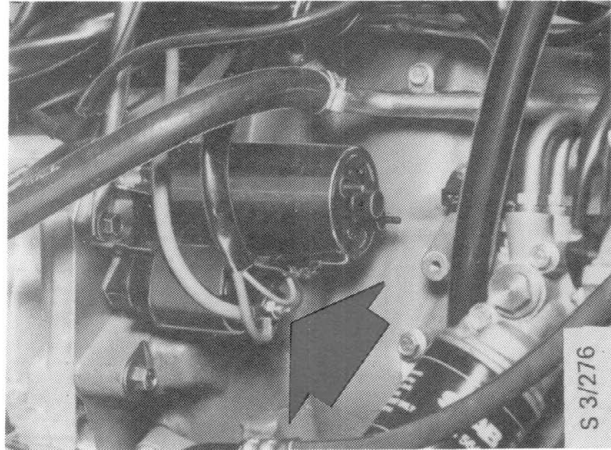

- 3 Slacken the top mounting of the stay bar. **Don't** remove the stay bar.

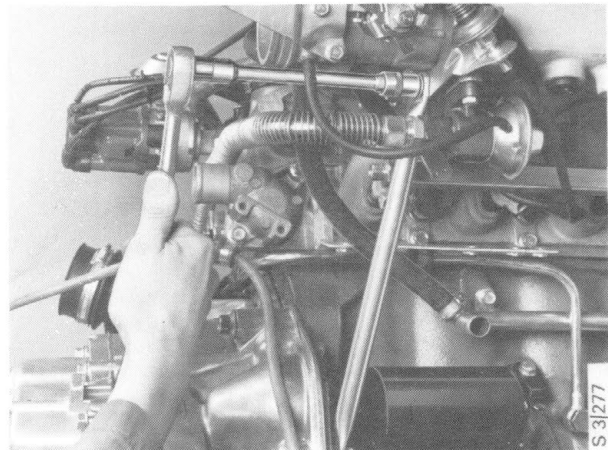

- 4 Remove the two starter motor securing bolts.

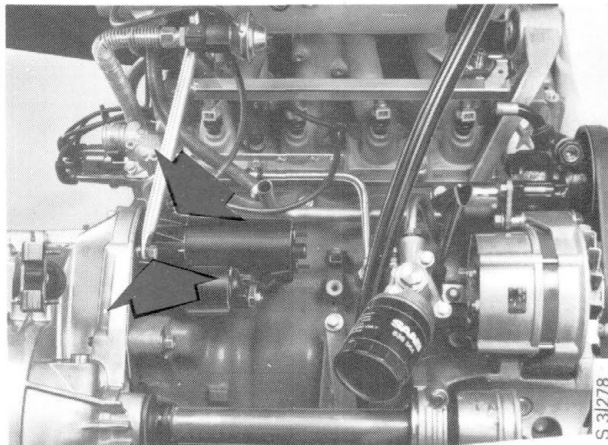

- 5 Remove the starter motor by dropping it down.



## To fit

Refit in the reverse order

## To dismantle

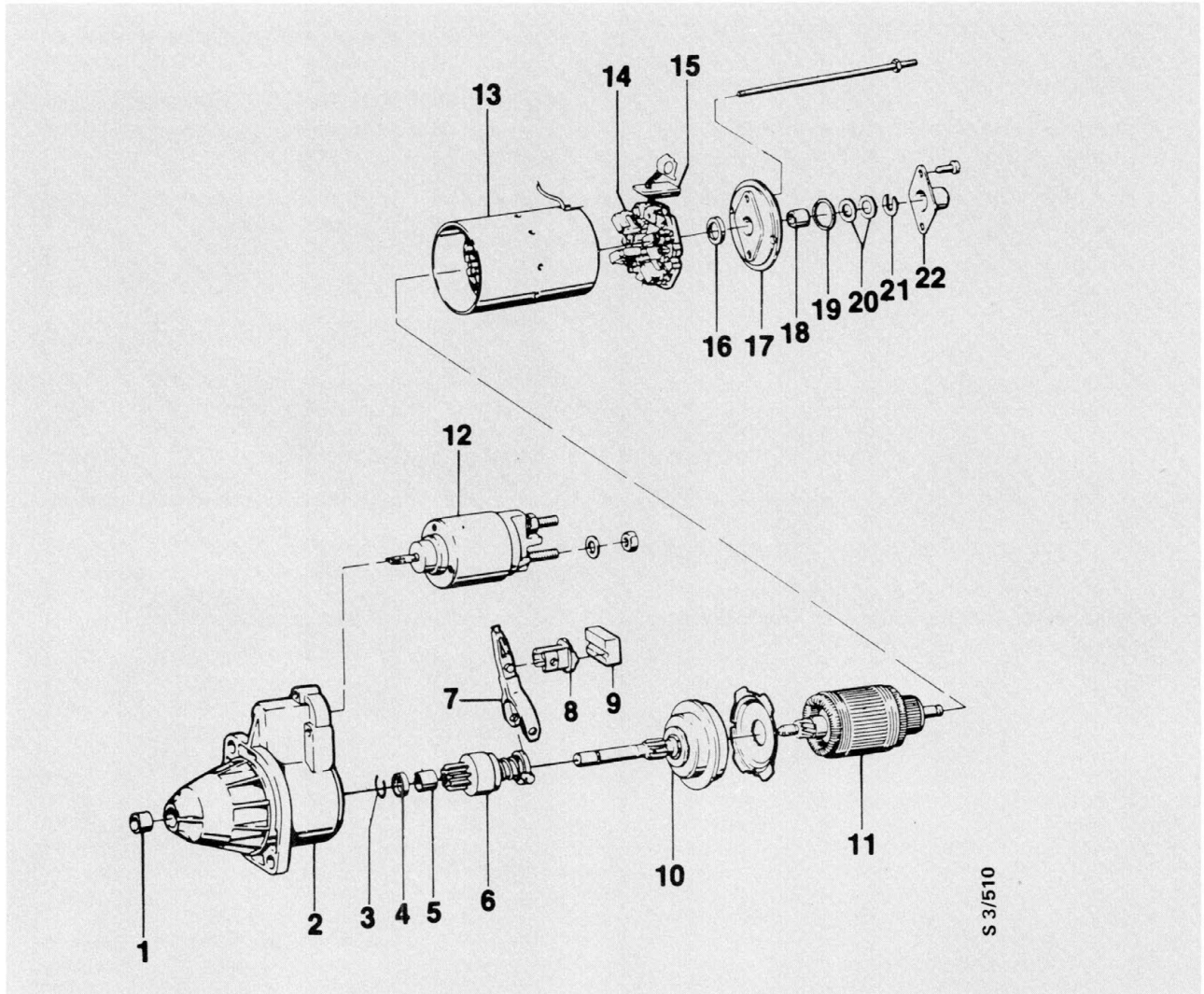

- |                           |                           |                  |
|---------------------------|---------------------------|------------------|
| 1 Drive end bush          | 11 Armature               | 21 Spring washer |
| 2 Pinion bracket assembly | 12 Solenoid               | 22 End cover     |
| 3 Circlip                 | 13 Stator frame           |                  |
| 4 Stop ring               | 14 Brush-holder assembly  |                  |
| 5 Pinion-end bush         | 15 Seal                   |                  |
| 6 Starter pinion          | 16 Seal                   |                  |
| 7 Pinion-engaging lever   | 17 Commutator end bracket |                  |
| 8 Bearing bracket         | 18 Commutator end bush    |                  |
| 9 Seal                    | 19 Seal                   |                  |
| 10 Planetary gear train   | 20 Shims                  |                  |

- 1 Disconnect the supply cable from the solenoid.



- 2 Remove the solenoid securing screws.



- 3 Unhook and remove the solenoid.



# 331-6 Starter Motor

4 Remove the two end-cover retaining screws.



S 3/282

5 Remove the spring washer, shim and seal.



S 3/283

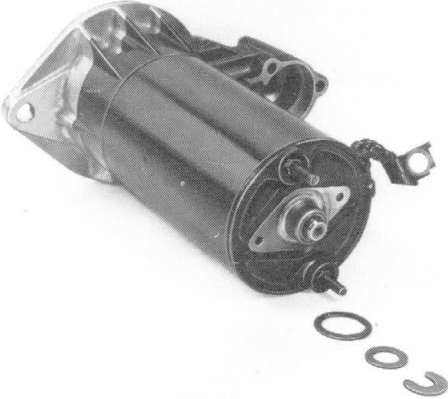

S 3/284

- 6 Remove the commutator end bracket screws.

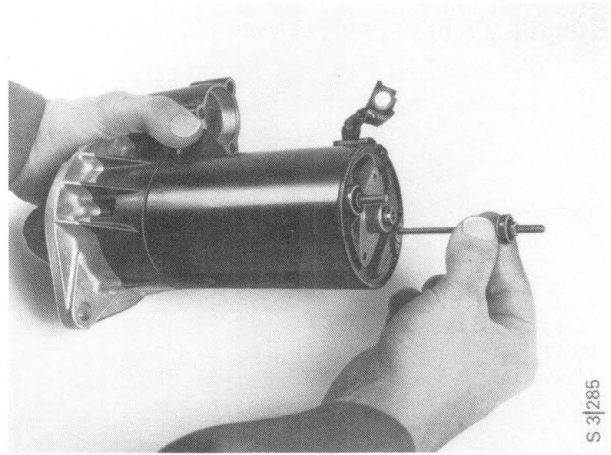

- 7 Separate the two halves of the starter motor by pulling the stator frame complete with armature and brush-holder assembly off the planetary gear housing.

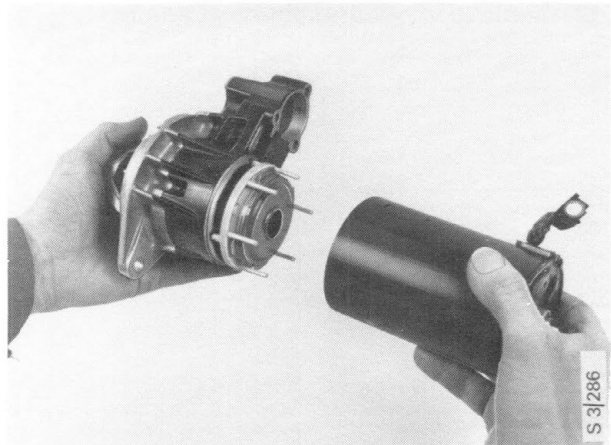

- 8 Remove the commutator end bracket and seal.

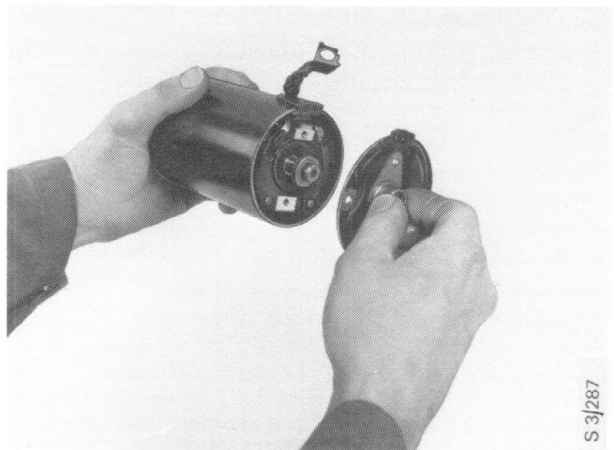

- 9 Withdraw the armature and brush-holder assembly through the rear of the starter motor stator frame.

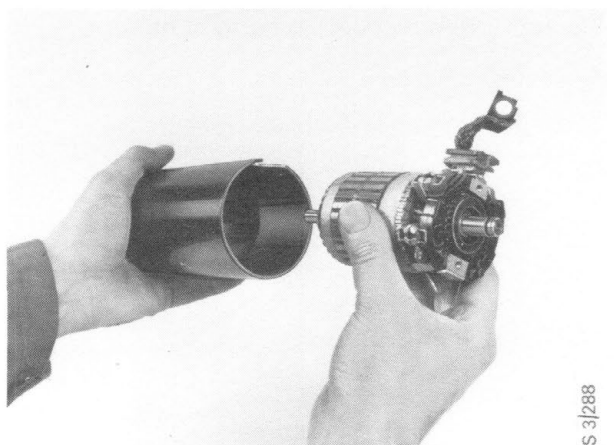

# 331-8 Starter Motor

10 Pull the brush-holder assembly off the armature.

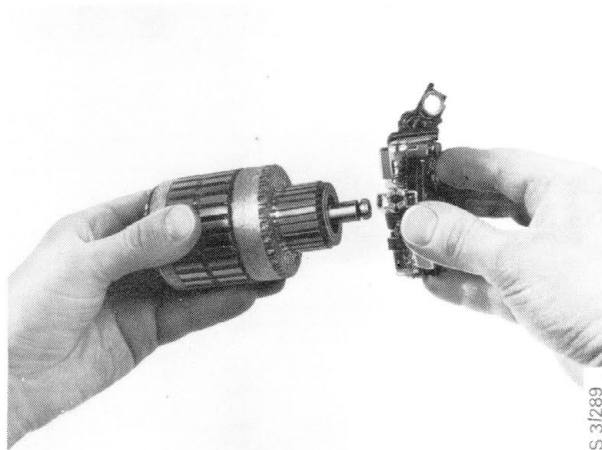

11 Remove the bearing bracket seal.

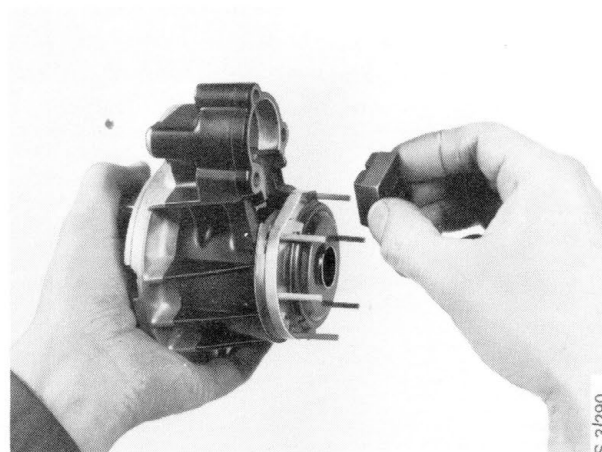

12 Withdraw the planetary gear train, the pinion-engaging lever and the pinion from the pinion bracket assembly.

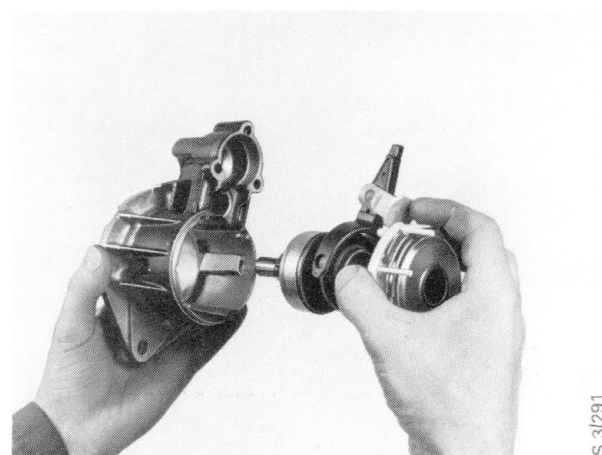

13 Remove the cover from the annulus.

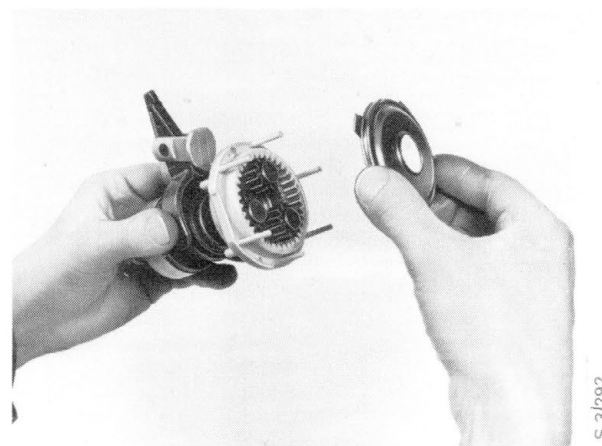

- 14 Use a short length of tube against the pinion to drive down the stop ring.

---

**N.B.**

The plastic legs of the annulus are fragile - treat them with great care.

---

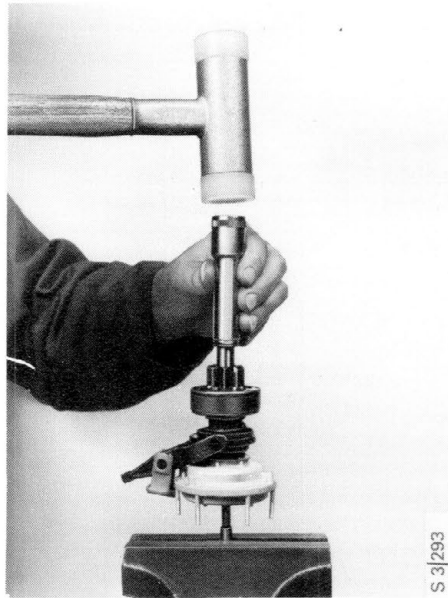

- 15 Use circlip pliers to remove the circlip, and pull off the pinion.

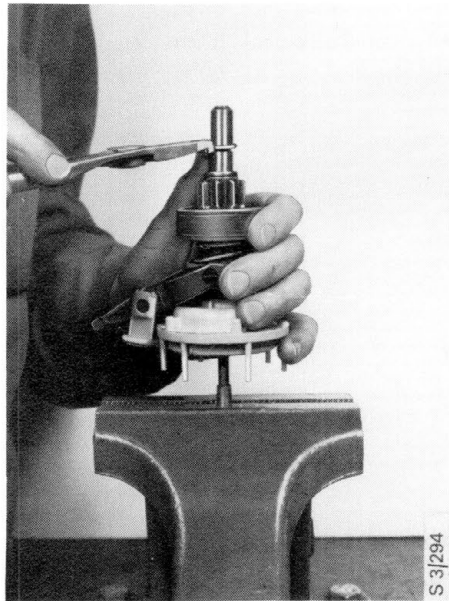

- 16 Remove the circlip and washer from the annulus and withdraw the planet gears from the housing.



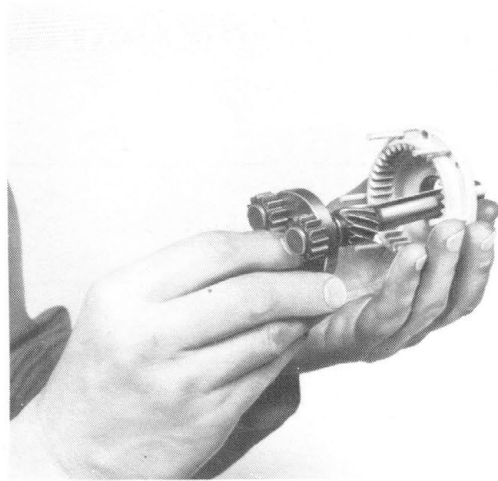

S 3/296

## To assemble

---

### **N.B.**

Inspect all parts carefully and renew any that are damaged. Soak the bushes in warm oil before fitting them.

---

- 1 Insert the planet gears into the annulus and fit the washer and circlip.

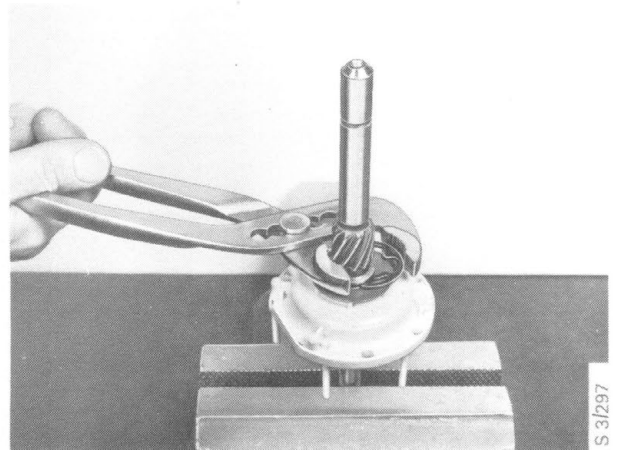

S 3/297

- 2 Lubricate the helix and the engagement ring for the starter motor pinion with silicone grease.

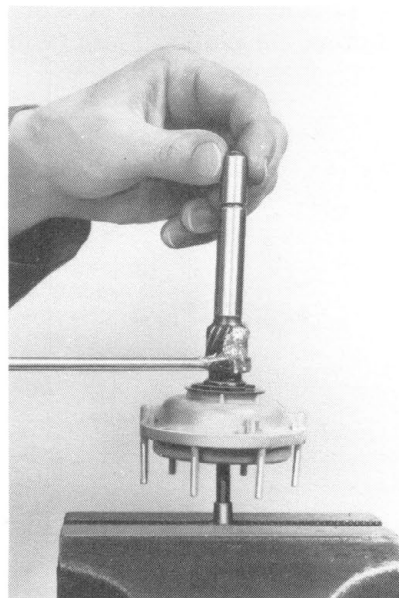

S 3/298

- 3 Slide the starter pinion and stop ring onto the shaft.
- 4 Use circlip pliers to fit the circlip into its groove.
- 5 Slide the stop ring up against the circlip by means of a jaw extractor.



S 3/300

- 6 Insert the planetary gear train, the pinion-engaging lever and the pinion into the pinion bracket, and fit the bearing bracket seal and the annulus cover.

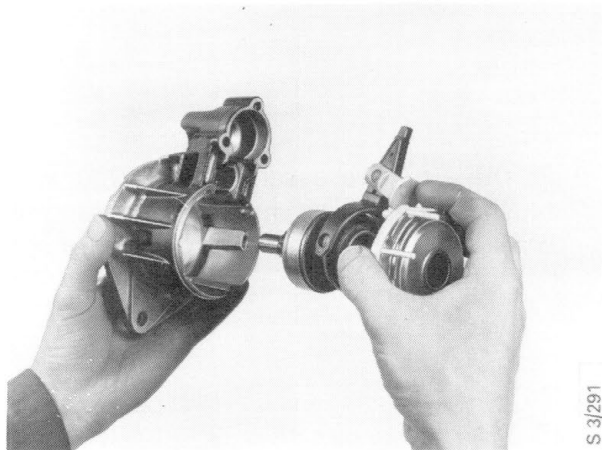

S 3/291

- 7 Fit the brush-holder assembly onto the armature shaft.

The easiest way is to slide the brush plate without the brush holder part-way onto the armature shaft. The brushes can then be properly centred, after which the brush holders and springs can be fitted over the brushes and guided into their proper positions.

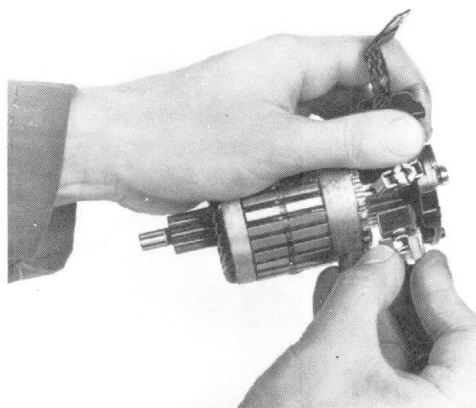

S 3/301



## 331-12 Starter Motor

- 8 Fit the commutator end bracket, the shim and the spring washer onto the armature.

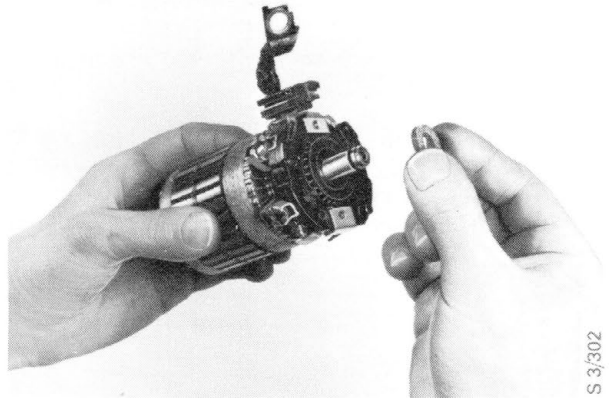

---

### N.B.

Before fitting the commutator end bracket, make sure that the seal between the bracket and the armature is in good condition and that it has been fitted correctly.

---

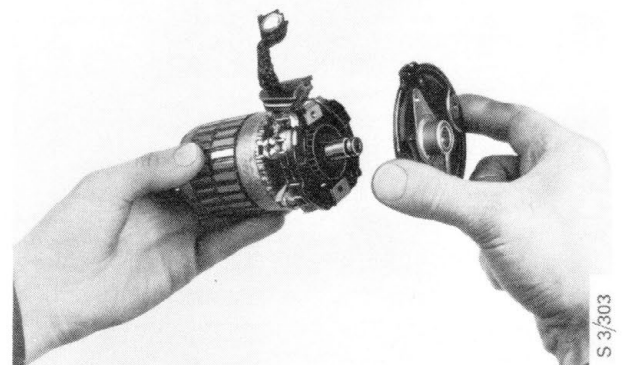

- 9 Fit the armature assembly, complete with brush holders, and the commutator end bracket into the starter motor stator frame.

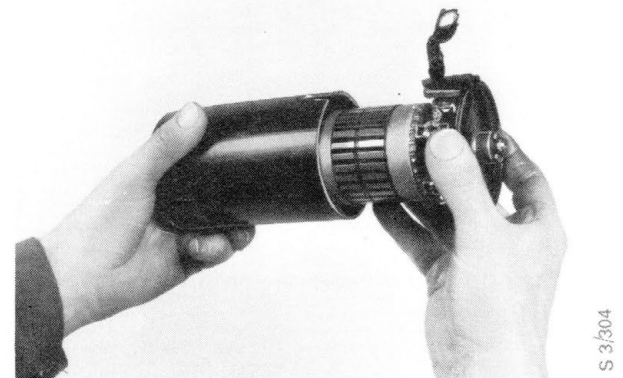

- 10 Assemble the starter motor stator frame and pinion assembly, and fit the long through-bolts.

- 11 Check the end float of the armature shaft, which should be between 0.05 and 0.40 mm (0.002 - 0.016 in).

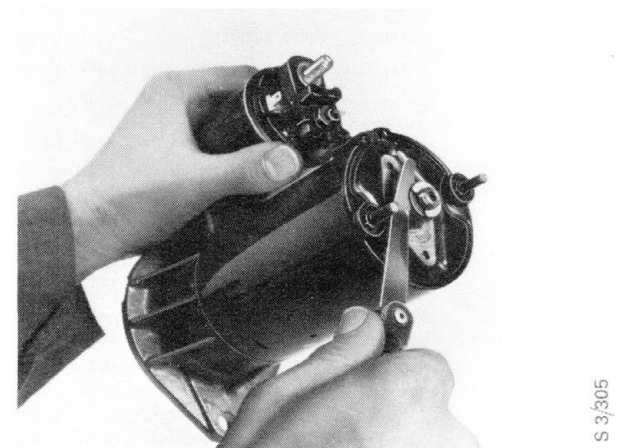

- 12 Fit the seal and end cover over the end of the armature shaft at the commutator end bracket.
- 13 Fit the solenoid and connect the supply cable.



S 3|281

**To remove the brush-holder assembly**

- 1 Remove the two screws retaining the end cover.



S 3|282

- 2 Remove the spring washer, shim and seal.



S 3|283

# 331-14 Starter Motor

---

- 3 Remove the commutator end bracket screws.



S 3/284

- 4 Remove the commutator end bracket.

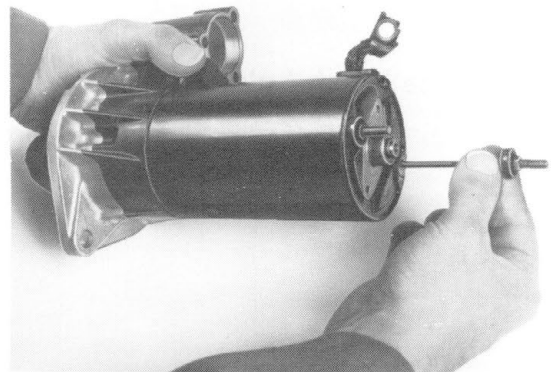

S 3/285

- 5 Withdraw the armature and brush-holder assembly through the rear of the starter motor stator frame.



S 3/287

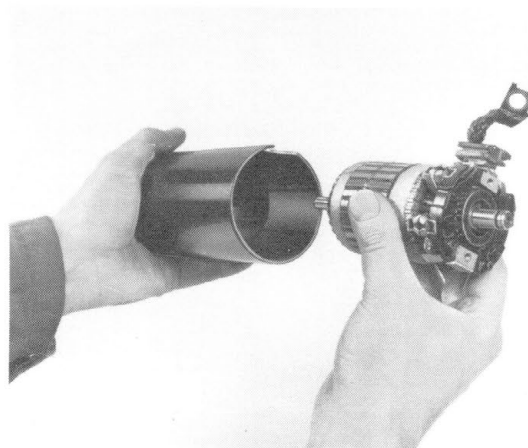

S 3/288

- 6 Remove the brush-holder assembly from the armature.

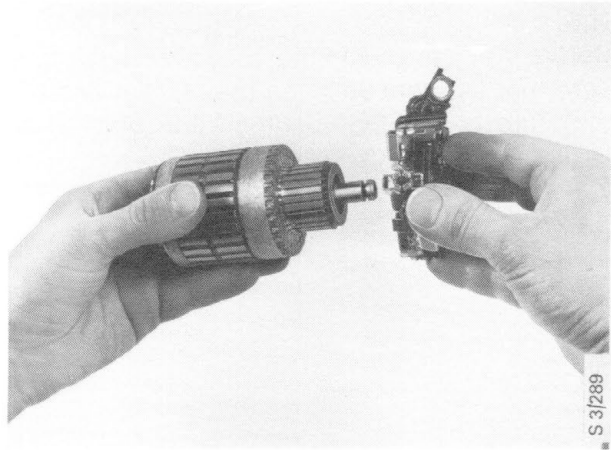

### To fit the brush-holder assembly

- 1 Fit the brush-holder assembly onto the armature shaft.

The easiest way is to slide the brush plate without the brush holder part-way onto the armature shaft. The brushes can then be properly centred, after which the brush holders and springs can be fitted over the brushes and guided into their proper positions.

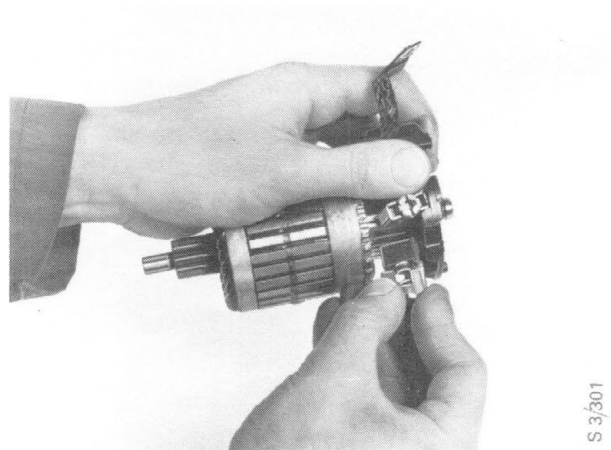

- 2 Fit the commutator end bracket, the shim and the spring washer onto the armature.

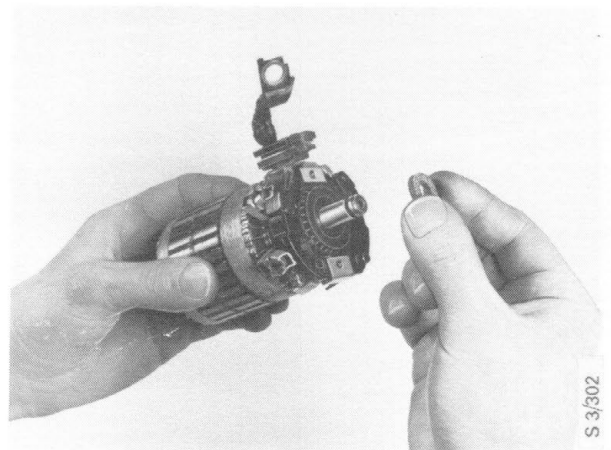

## 331-16 Starter Motor

---

### **N.B.**

Before fitting the commutator end bracket, make sure that the seal between the bracket and the armature is in good condition and that it has been fitted correctly.

---

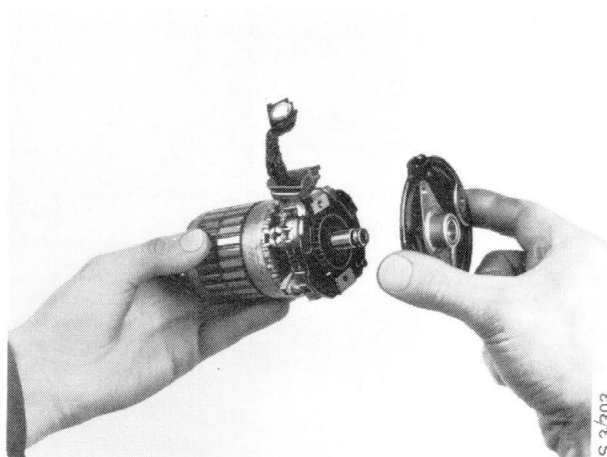

- 3 Fit the armature, brush-holder assembly and commutator end bracket into the starter motor stator frame.

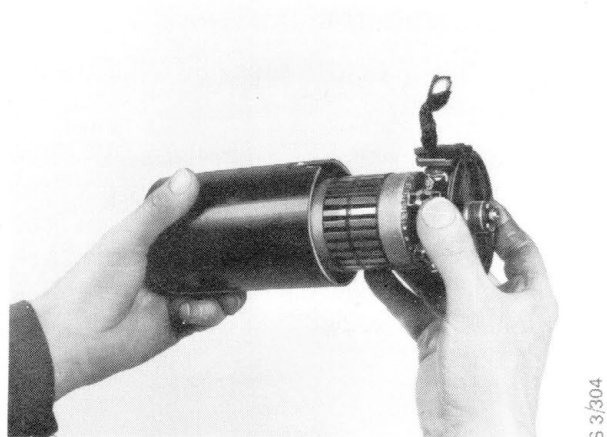

- 4 Fit the seal and end cover.



**To remove the pinion**

- 1 Disconnect the supply cable from the solenoid.



- 2 Remove the securing screws for the solenoid.



- 3 Unhook and remove the solenoid.



## 331-18 Starter Motor

- 4 Remove the commutator end bracket securing screws.

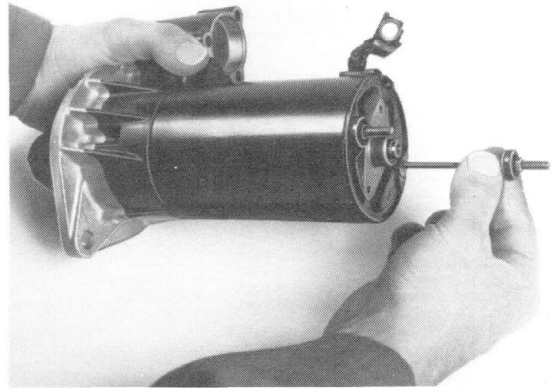

S 3/285

- 5 Pull off the pinion assembly and remove the bearing bracket seal.

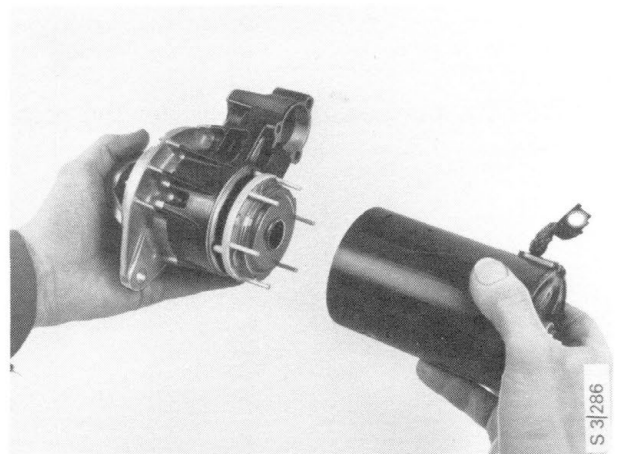

S 3/286

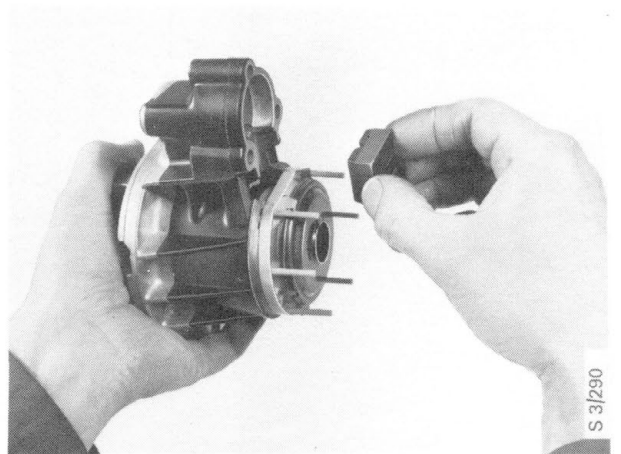

S 3/290

- 6 Withdraw the planetary gear train, the pinion-engaging lever and the pinion from the pinion bracket.



S 3/291

- 7 Press the stop ring down against the pinion, using a piece of tube.

---

**N.B.**

The plastic legs of the annulus are fragile - treat them with great care.

---



S 3|293

- 8 Use circlip pliers to remove the circlip, and withdraw the pinion.



S 3|294

- 9 Remove the stop ring and pinion.
- 10 Check for any burrs on the helix for the pinion on the armature shaft. File off any burrs.



### To fit the pinion

- 1 Lubricate the helix on the armature shaft and the engaging ring with silicone grease.

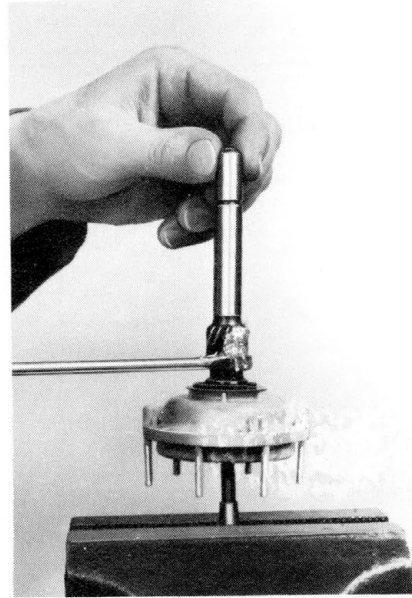

- 2 Slide the starter pinion and stop ring onto the armature shaft.

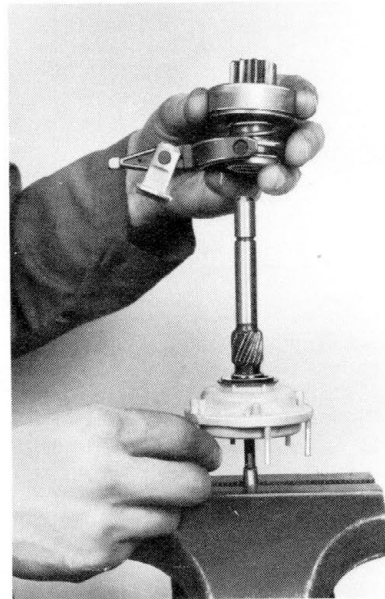

- 3 Use circlip pliers to fit the circlip into its groove.

- 4 Slide the stop ring up against the circlip by means of a jaw extractor.



- 5 Insert the planetary gear train, the pinion-engaging lever and the pinion into the pinion bracket and fit the bearing bracket seal and annulus cover.

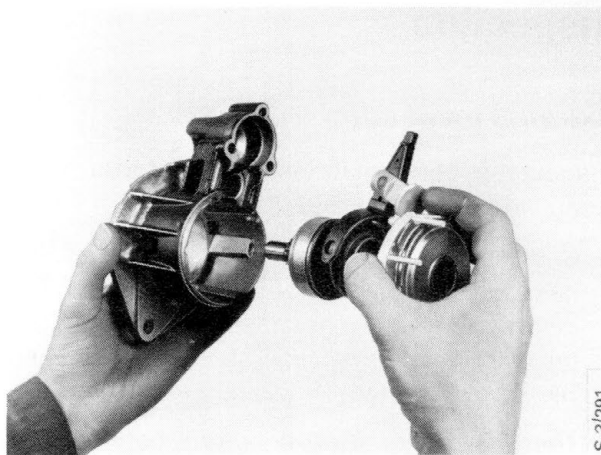

- 6 Fit and tighten the commutator end bracket through-bolts.

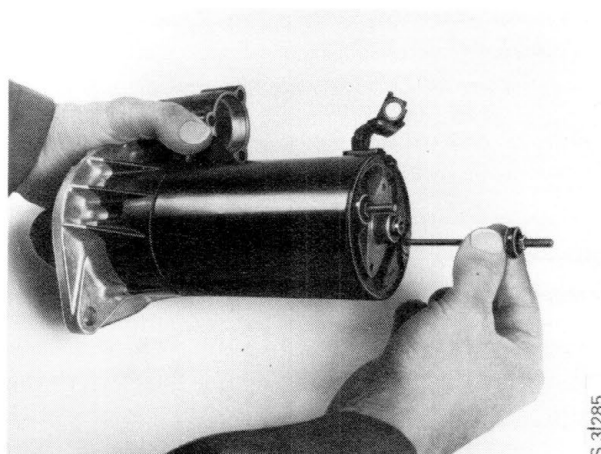

- 7 Hook the solenoid onto the pinion-engaging lever and tighten the screws.



- 8 Connect the supply cable.

## Inspection

### External inspection

Inspect the following items with the starter motor removed from the car but not dismantled:

- Check that the stop ring for the starter pinion has been fitted correctly and securely. The distance between the stop ring and the starter-motor mounting face should be between 31.3 and 32.6 mm (1.22 - 1.27 in).
- There is risk of short-circuiting between the braided cable from the solenoid to the brush-holder assembly and earth. Make sure that the cable is well clear of the starter motor stator frame and remove any dirt deposits.
- Make sure that all seals are in good condition and have been fitted correctly.

### Armature end float

To check the end float of the armature shaft, remove the end cover and measure the float of the shaft.

The end float should be between 0.05 and 0.40 mm (0.002-0.016 in).

To adjust the end float, fit new shims under the rear end cover.

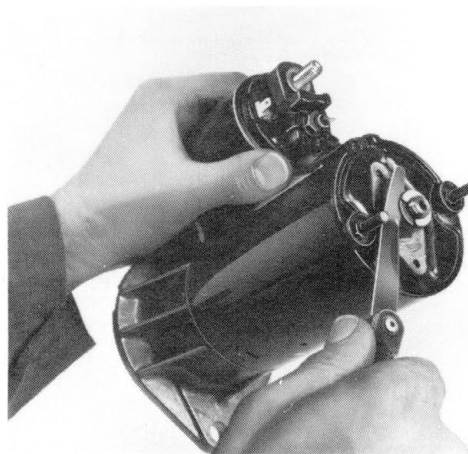

# Ignition system

Principle of operation . . . . .	340-1	Checking and adjusting the timing . .	340-12
Replacement of components . . . . .	340-5	Testing and inspecting the	
Ignition timing equipment with		components . . . . .	340-13
service instrument . . . . .	340-10	Fault tracing . . . . .	340-16
Vacuum control . . . . .	340-11	Fault-tracing chart . . . . .	340-17
Pressure control . . . . .	340-12	Ignition system with knock sensor . .	340-18

The Saab 9000 is fitted with a breakerless ignition system incorporating a Hall sensor.

## Principle of operation

Instead of mechanical contact-breaker points, the distributor incorporates a semiconductor transducer (Hall sensor) which is connected to an amplifier. The amplifier amplifies and converts the signal from the sensor. This signal is then used to control the charging and discharging of the ignition coil.

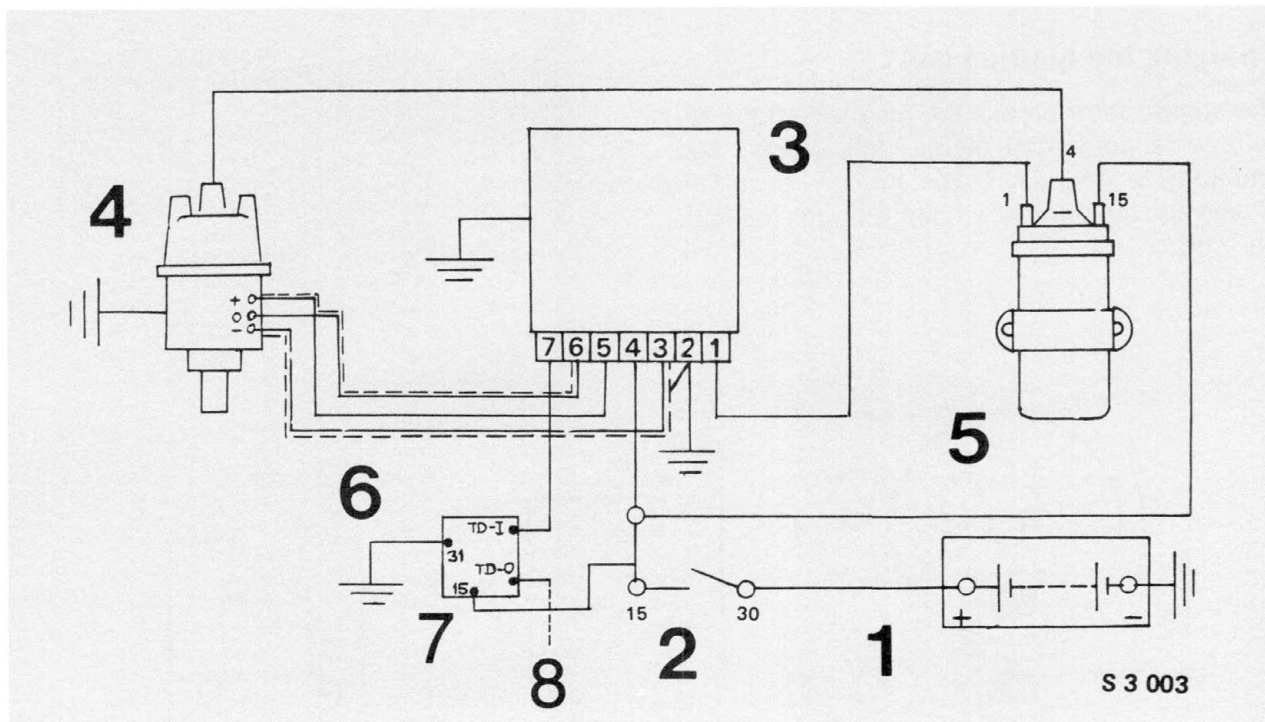

- 1 Battery
- 2 Ignition switch
- 3 Amplifier
- 4 Distributor
- 5 Ignition coil
- 6 Shielded cable
- 7 Ignition pulse amplifier
- 8 Ignition pulse output

## Distributor

The distributor incorporates a slotted rotor, which rotates with the distributor shaft, and a Hall sensor fitted to a plate inside the distributor. The sensor consists of a semiconductor element and a magnet which acts on the semiconductor. The slotted rotor alternately interrupts and releases the magnetic field, thereby determining the ignition timing.

### N.B.

The Hall sensor and the rotor cannot be removed separately. If the sensor unit is suspected of being defective, the entire distributor must be replaced.

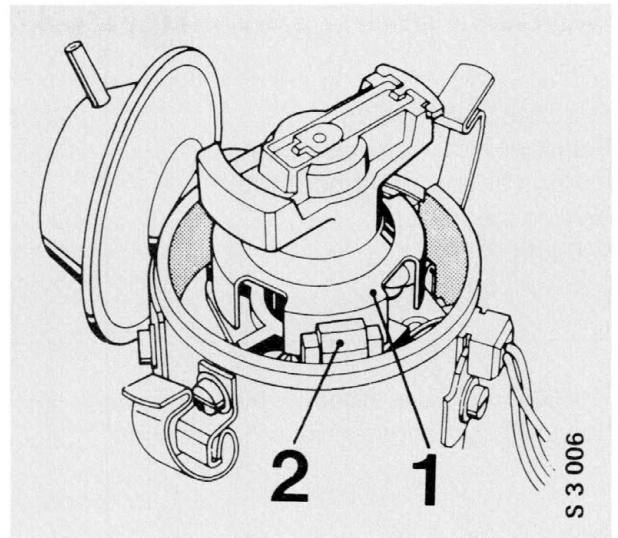

- 1 Slotted rotor
- 2 Hall sensor

The distributor has a double-acting vacuum timing control device which alters the timing to match the load on the engine. Thus, in addition to conventional vacuum control, the distributor includes a pressure-regulating function which retards the timing under certain conditions. The system is therefore able to prevent knocking when the turbocharger is boosting the intake air pressure.

## Charging the ignition coil

The slotted rotor breaks the magnetic field. No voltage is generated in the Hall sensor. The amplifier is energised, the primary circuit is closed and the primary winding charges the ignition coil.

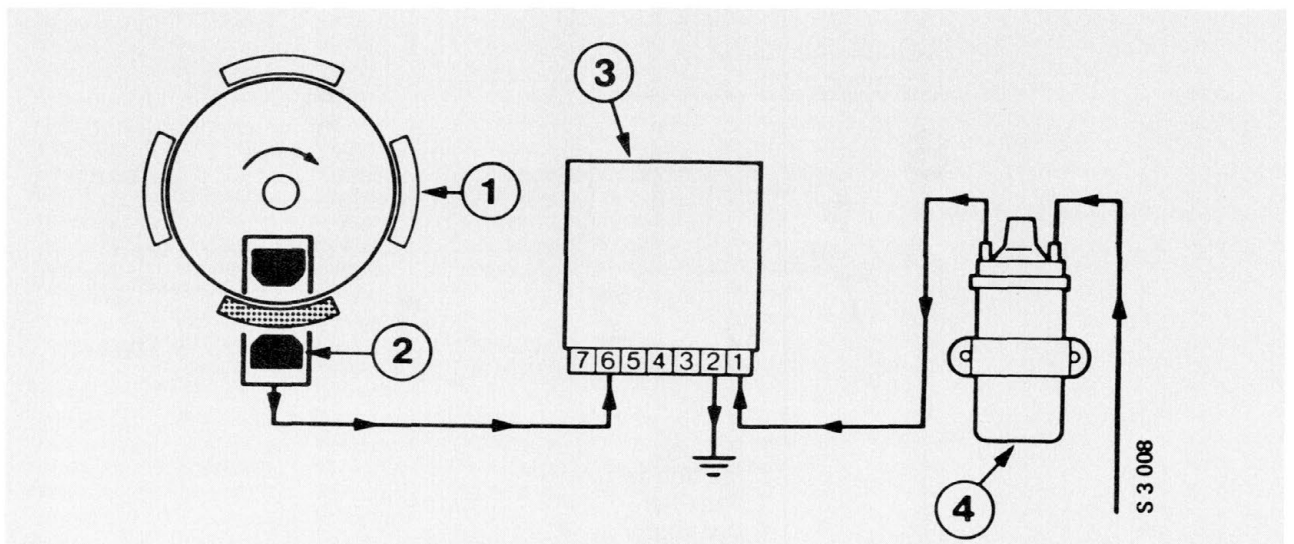

- 1 Slotted rotor
- 2 Hall sensor
- 3 Amplifier
- 4 Ignition coil

## Firing instant

The slot in the rotor is in line with the Hall sensor. The voltage generated in the sensor is sensed by the amplifier, which breaks the primary circuit. The spark-firing voltage is now induced in the secondary winding of the coil.

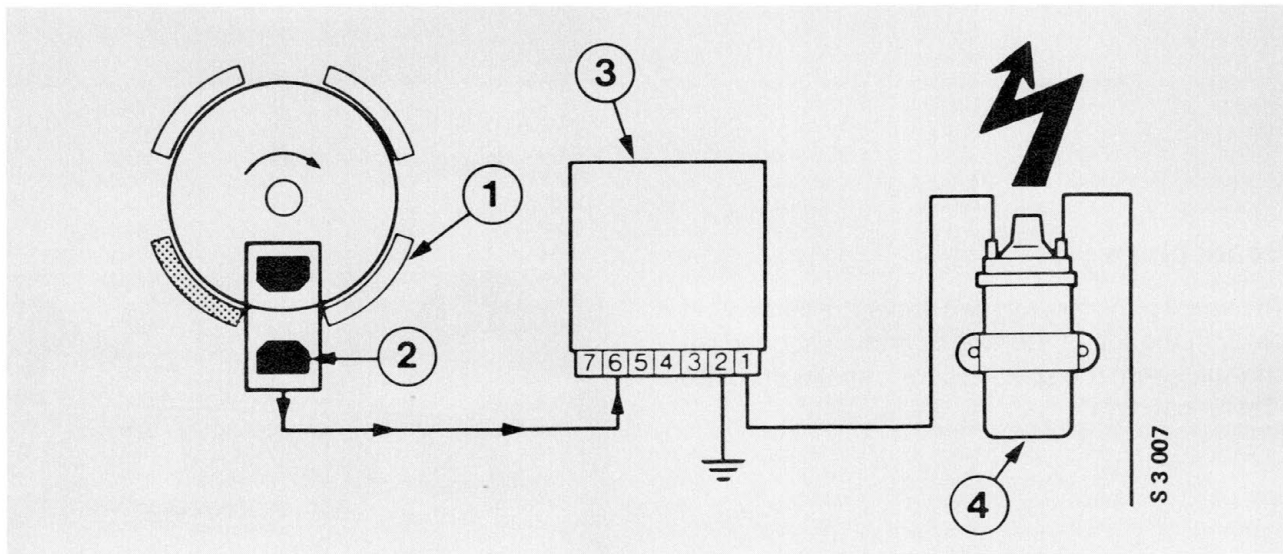

- 1 Slotted rotor
- 2 Hall sensor
- 3 Amplifier
- 4 Ignition coil

## Amplifier

The amplifier is mounted on a cooling plate on the left-hand wheel housing.

The amplifier amplifies and converts the pulse from the distributor. The amplified and converted pulse is then used to control the charging and discharging of the coil.

The amplifier also monitors and controls the dwell angle.

The use of hybrid technology in the design of the module has made it possible to produce an extremely compact amplifier.

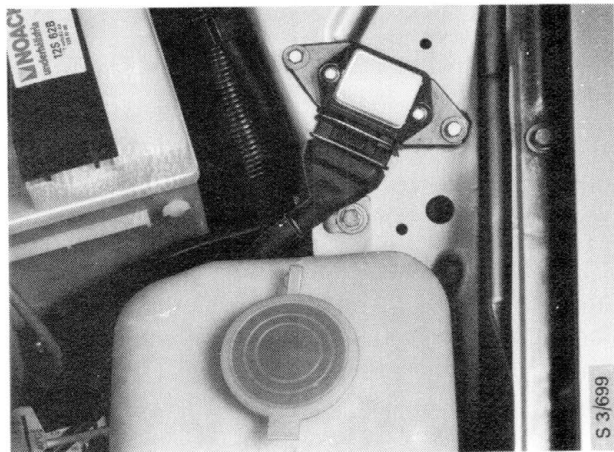

## 340-4 Ignition system

### Ignition coil

The ignition coil, which is specially designed for the ignition system in the Saab 9000, is mounted on top of the radiator.

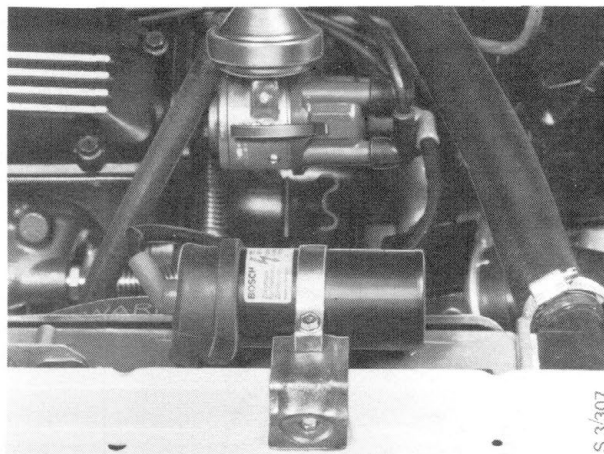

S 3/307

### Spark plugs

The spark plugs are located under the inspection cover in the top of the engine and must be in accordance with the specifications on Section 023 "Technical data".

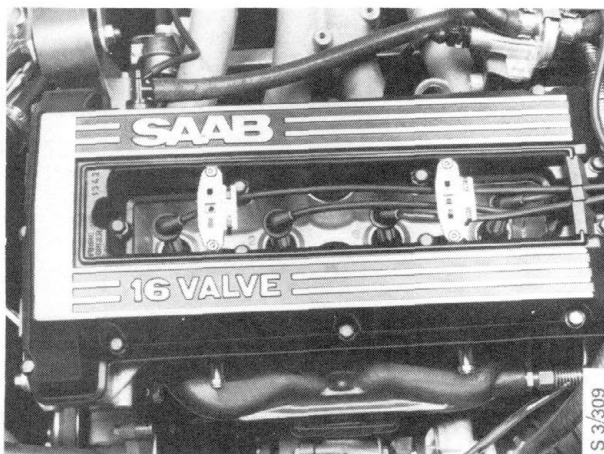

S 3/309

### Ignition pulse amplifier

The ignition system is equipped with an ignition pulse amplifier located in the electrical distribution box, behind the glove compartment.

The ignition pulse amplifier provides more reliable control of the electronic components affected by the ignition (the APC and LH systems) and reduces the radio interference.

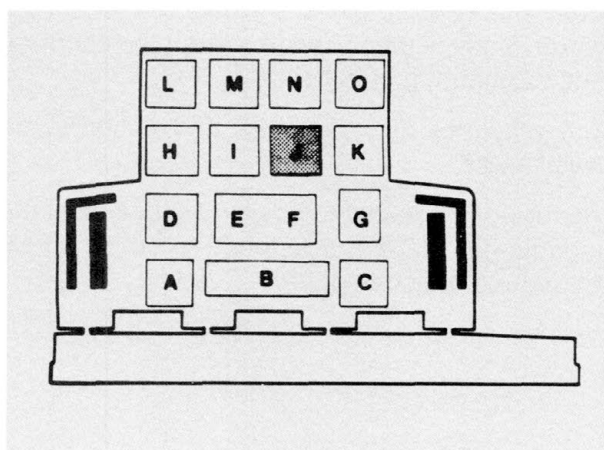

## Replacement of components

### Distributor

- 1 Remove the distributor cap and disconnect the Hall sensor and vacuum hose.

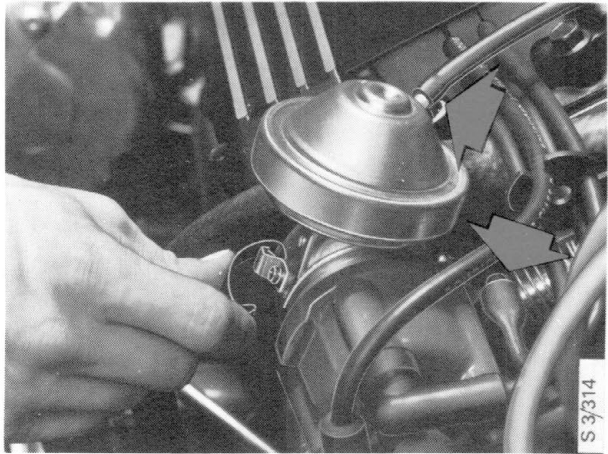

- 2 Release the clip on the distributor.

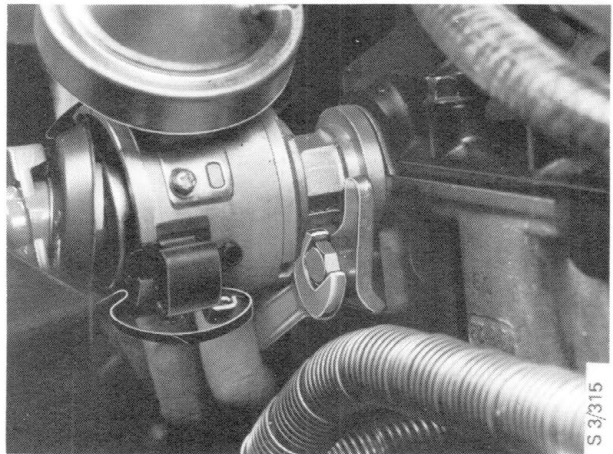

- 3 Withdraw the distributor.

---

**N.B.**

The Hall sensor and slotted rotor cannot be removed. In the event of a fault on this unit, a new distributor must be fitted.

---





### To fit

Refit in the reverse order.

---

#### N.B.

When refitting the distributor, rotate the distributor shaft until the drive dog engages the slot in the camshaft (the slot is offset).

---

Always check the timing after refitting the distributor.

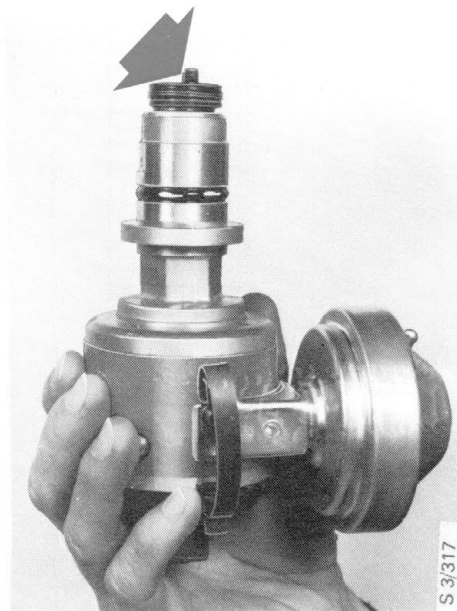

### Rotor

- 1 Remove the distributor cap.
- 2 To remove the rotor, crush it with a pair of sturdy pliers.

---

#### N.B.

Make sure that no fragments of the crushed rotor get into the distributor.

---

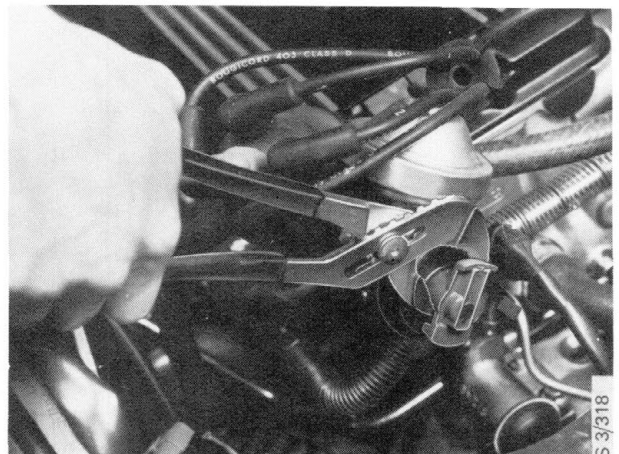

---

#### N.B.

When a new rotor is fitted, it must be locked to the distributor shaft by means of Loctite 601 or the equivalent locking compound.

---

### Vacuum control unit

- 1 Remove the distributor cap.
- 2 Disconnect the vacuum hose.
- 3 Remove the screws securing the vacuum control unit.

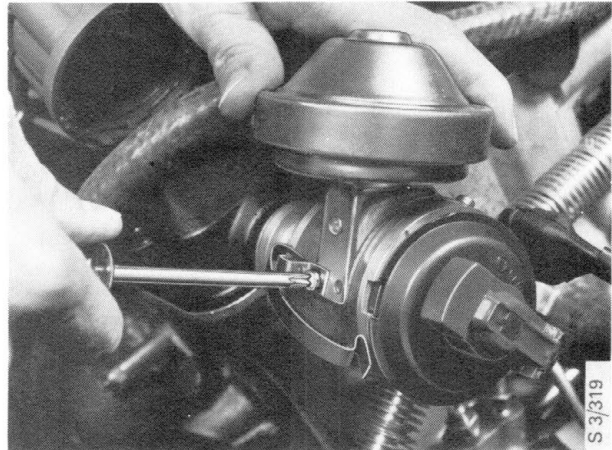

- 4 Remove the vacuum control unit.

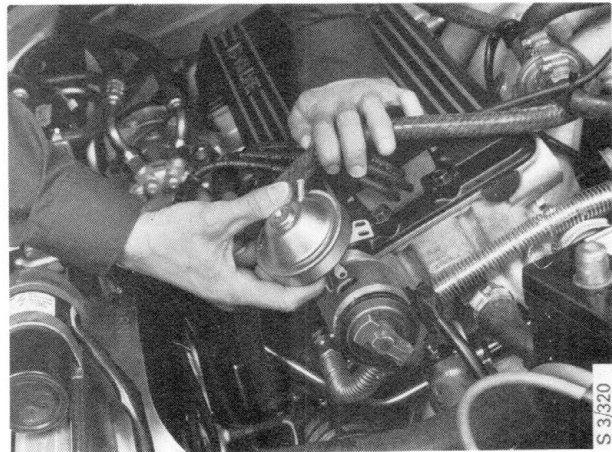

### To fit

Refit in the reverse order.

To facilitate fitting of the unit, rotate the Hall sensor clockwise until it butts against its stop and then rock it backwards and forwards while hooking the actuating lever from the vacuum control unit onto the pin in the distributor.

---

### N.B.

Never bring any metal tools into contact with the Hall sensor. To move it, use either a finger or a suitable plastic tool, and always exercise great care.

---

### Amplifier

- 1 Disconnect the wiring from the amplifier.

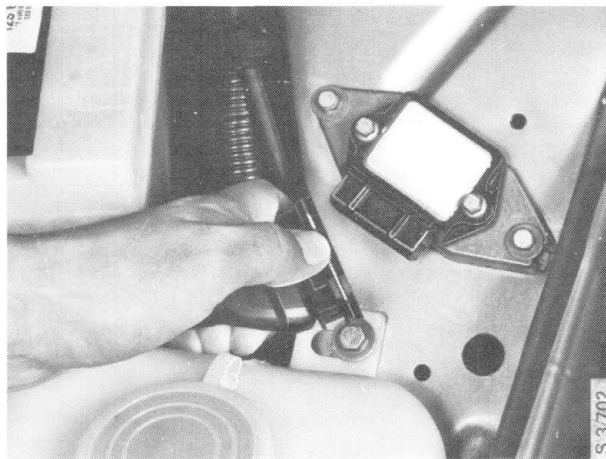

- 2 Unscrew the amplifier from the cooling plate.

### To fit

Refit in the reverse order

### Ignition coil

- 1 Roll back the rubber dust cover on the ignition coil.

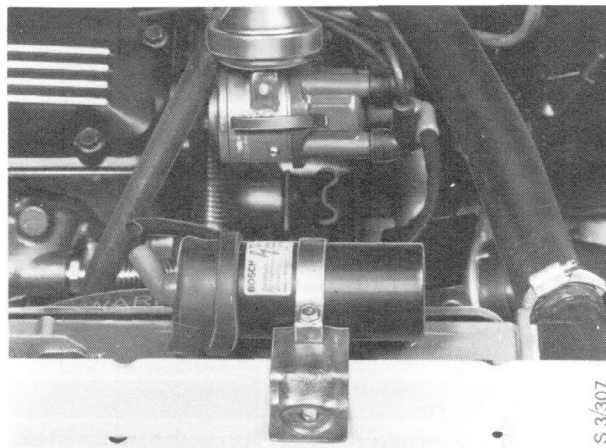

- 2 Disconnect the cables from the coil.
- 3 Remove the coil.

### To fit

Refit in the reverse order.

## Spark plugs

- 1 Remove the cover over the spark plugs.

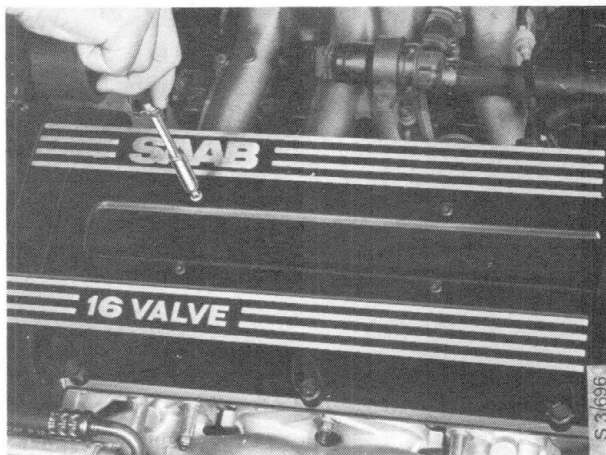

- 2 Pull off the plug caps - don't pull the leads.
- 3 Blow compressed air around the plugs to remove any dirt.
- 4 Remove the plugs using spark plug socket 83 93 902.



## To fit

Refit in the reverse order.

### N.B.

When refitting the clips, make sure that the leads are secured in the clips.

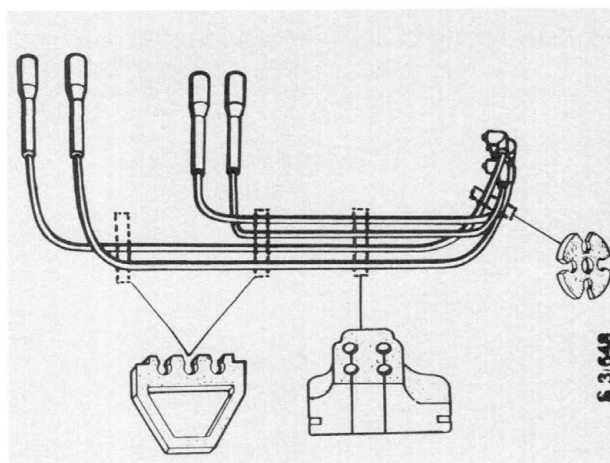

*Ignition lead runs*

## Ignition timing equipment

The engine includes provision for using an ignition-timing instrument. A special pin is provided on the flywheel and a test socket is incorporated into the flywheel cover. (Graduations are also provided on the flywheel for checking the timing with a conventional stroboscopic lamp.) Remove the plastic cover over the flywheel graduations by pressing in the locking hook and turning the cover upwards.

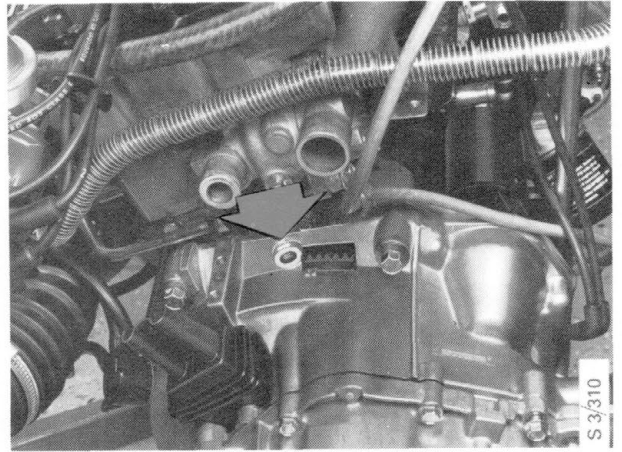

The timing instrument has a special plug which fits into the socket in the flywheel cover and a pulse sensor for the HT lead for No. 1 cylinder.

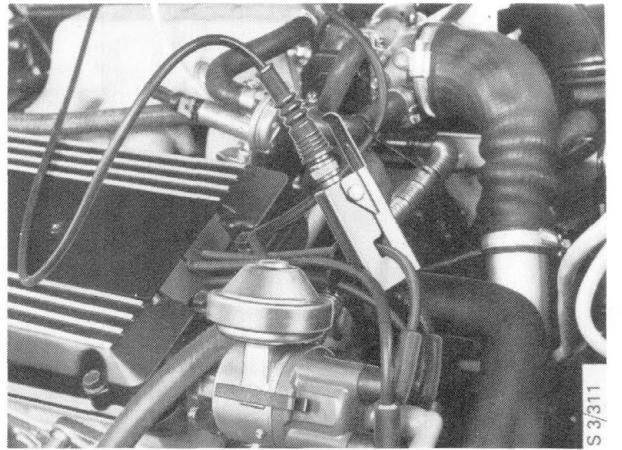

The timing service instrument (TSI) can be connected to the ignition service socket on the car. The instrument includes a tachometer, a dwell-angle meter, a stroboscopic lamp, a switch for the starter motor and, in the latest version, an ignition-timing meter with a graduated dial.

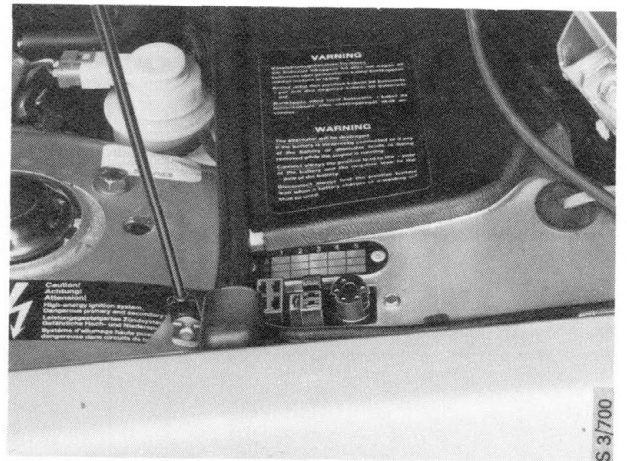

**Caution**

Remember to check that the car is in neutral before switching on the starter motor.

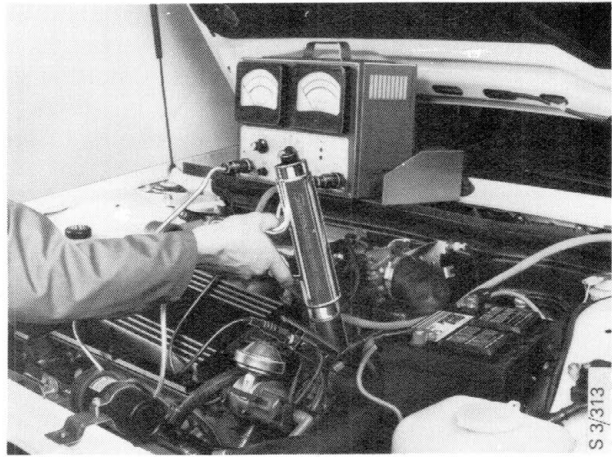

When the engine is being run by means of the TSI, the ignition switch is by-passed, and the radiator fan will therefore not run. So if the engine is run for more than about ten minutes, the ignition system should be switched on by means of the ignition switch, to enable the fan to run.

N.B. Bear in mind that when the ignition is switched on, all other electrical components connected across the ignition switch will also be switched on.

**Vacuum control**

- 1 Connect the timing service instrument (TSI) to the socket in the car.

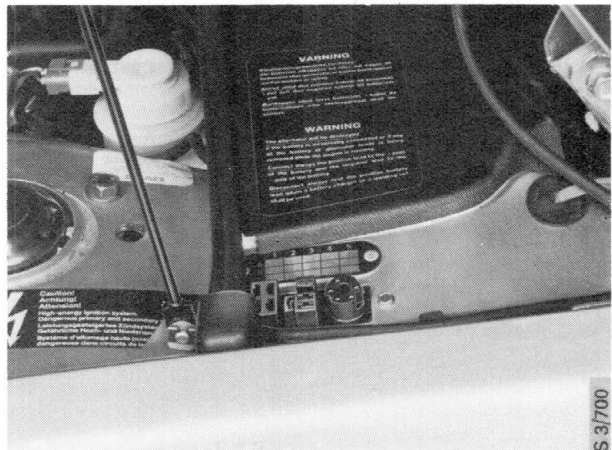

- 2 Disconnect the vacuum hose from the throttle housing.
- 3 Start the engine and run it at approximately 2500 r/min.

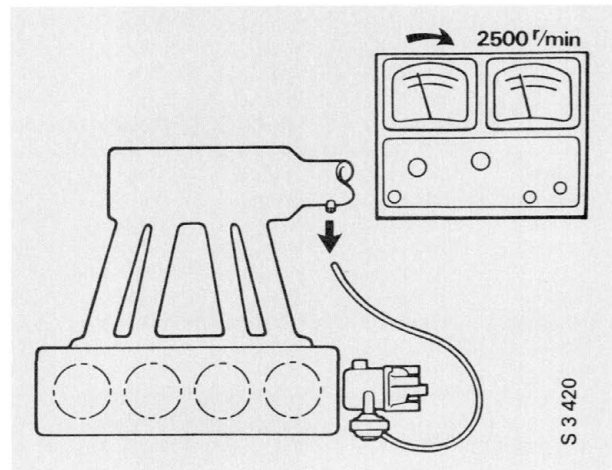

- 4 Read the ignition timing.
- 5 Connect the vacuum hose to the throttle housing.
- 6 Check that the timing has now advanced appreciably.

## Pressure control

- 1 Connect the timing service instrument (TSI) to the socket in the car.
- 2 Disconnect the vacuum hose from the throttle housing.
- 3 Connect instrument 83 93 514 and a suitable pressure tester to the hose.
- 4 Start the engine and let it run at idling speed.
- 5 Read the timing.
- 6 Raise the pressure to 0.5 bar.
- 7 Check that the timing has now retarded by 3 - 7°.

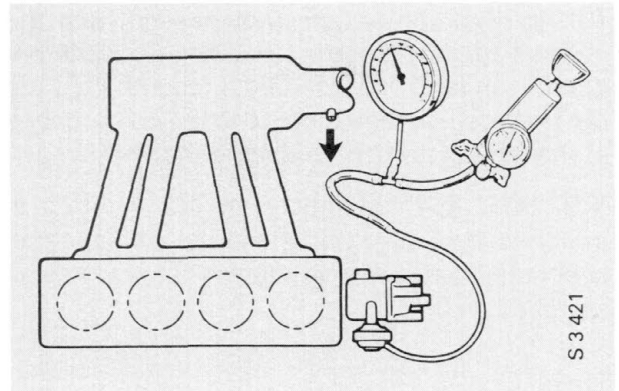
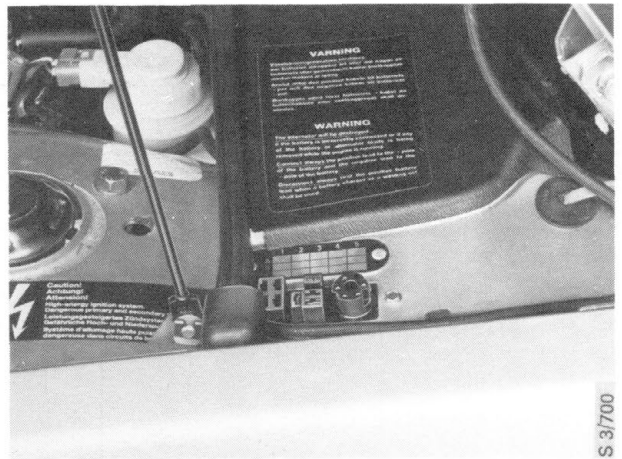

## Checking and adjusting the timing

- 1 Connect the timing service instrument (TSI) to the socket in the car.

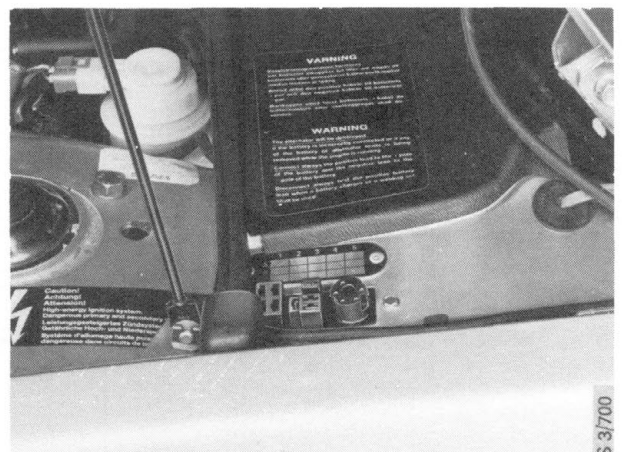

- 2 Disconnect the vacuum hose from the throttle housing.
- 3 Start the engine and run it at 850-875 r/min.

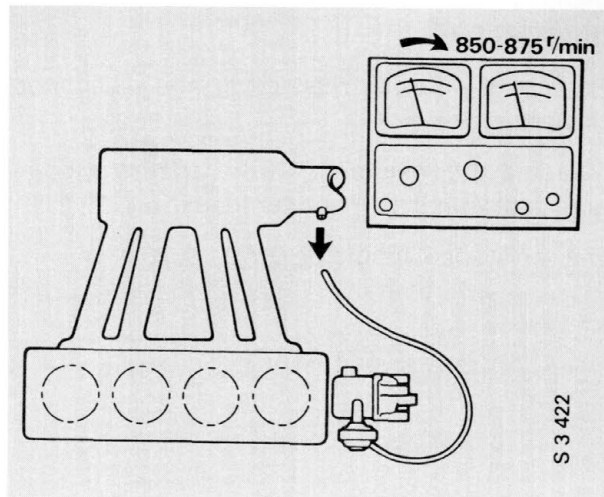

- 4 Check the timing and adjust as necessary.

## Testing and inspecting the components

### Distributor

The Hall sensor and slotted rotor cannot be removed. In the event of a fault in the sensor unit, the entire distributor must be replaced.

### Rotor

The rotor should have a resistance of 1 kohm.

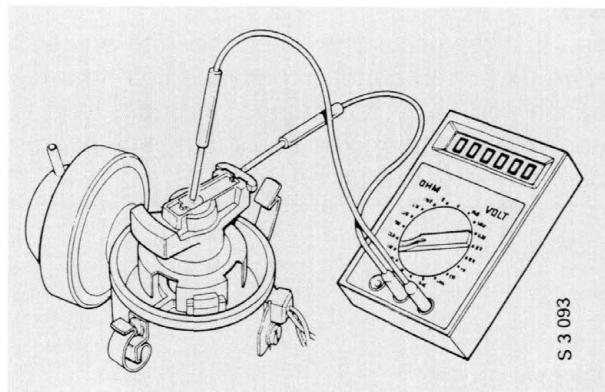

### HT leads

The HT leads and connections should have the following resistance values:

Lead between ignition coil and distributor: 0.5-1.5 kohm

Lead between distributor and spark plug: 2-4 kohm.



### Ignition coil

Remove the rubber dust cover and disconnect the leads.

Measure the resistance in the primary winding across terminal 1 (-) and terminal 15 (+).

The resistance should be 0.52 - 0.76 ohm.

Measure the resistance in the secondary winding across terminal 1 (-) and the HT terminal.

The resistance should be 7.2 - 8.2 kohm.

Measure the performance of the coil either in volts or by measuring the length of the spark.

---

#### **N.B.**

Faults often occur only when the ignition coil is warm. When in doubt, mount the coil on a test bench and leave it switched on under load for about half an hour. The coil should still operate perfectly after this time.

---

### Spark plugs

Check that the electrode gap is 0.6 mm (0.02 in).

If necessary, adjust by bending the side electrode.

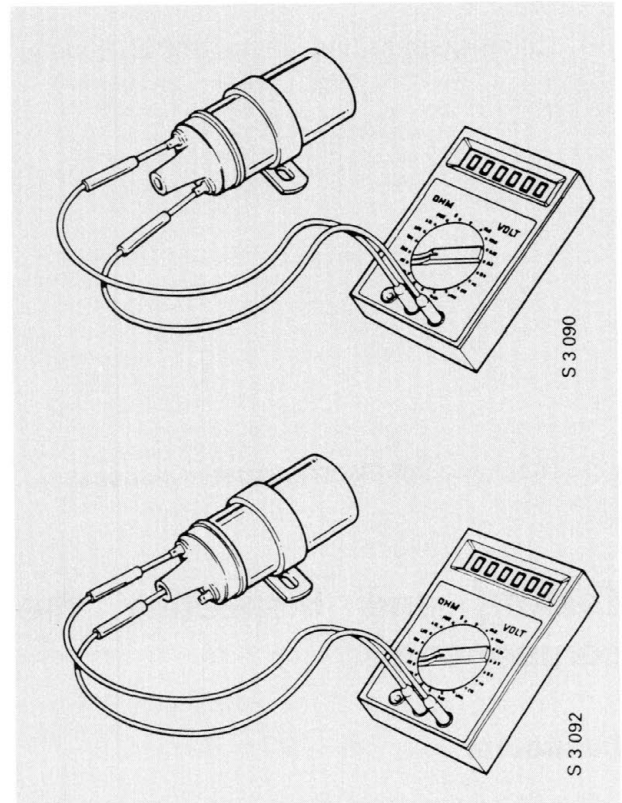

## Testing the distributor on a test bench.

Test in accordance with the instructions for the test equipment. The test values should agree with the distributor characteristics in Section 023 "Technical data".

### **N.B.**

The distributor rotates at half the engine speed.

Bear the following in mind when carrying out work on the electronic ignition system:

### **Caution**

The electronic ignition system has an ignition voltage of over 30 000 V and is within the power range that may be lethal to sensitive persons, such as those who have a pacemaker.

### **Caution**

Because of the damage that may result from flashover at the ignition coil, HT leads, distributor and the amplifier following must be observed:

- Never disconnect an HT lead when the engine is running.
- Never attempt to start the engine if any HT lead has been disconnected or if the distributor cap has been removed.
- Before carrying out a compression test or the like, always disconnect the amplifier.

To check the ignition spark, proceed as follows:

- a Unscrew the spark plug or use a separate plug.
- b Connect the HT lead to the plug.
- c Hold the plug against the engine so that it is well earthed.
- d Check the spark.

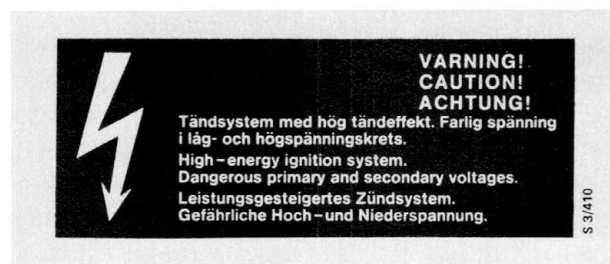

### **Caution**

Because of the high ignition energy, dangerously high voltages may also occur in the primary circuit (terminal 1) of the ignition coil and in the associated cables (including the tachometer socket, the TSI socket and the amplifier) when the engine is running.

When the ignition is switched on, the current in the primary winding of the ignition coil will always be a maximum. When working on the electrical system with the ignition switched on, disconnect terminal 1 (-) of the ignition coil.

### **Fault tracing**

The fault-tracing procedure should be followed step by step, and the necessary checks and action should be taken. If a component is found to be faulty, it should be exchanged before the next step is started. If, for instance, a fault tends to occur at certain temperatures, always try to trace the fault within this temperature range. Thus, if starting problems occur when the engine is cold, try to trace the fault when the engine is cold. A defective electronic component often performs correctly at normal temperatures before it breaks down completely. Poor contact is also affected by temperature.

### **Fault-tracing equipment**

Ignition timing instrument (preferably with a 90° dwell-angle scale), a voltmeter/ohmmeter with scales for 15 V d.c., 5 V a.c. and a minimum sensitivity of 10 000 ohm/V, and scales for 0 - 5 ohm and 0 - 5 kohm.

# Fault-diagnosis chart

## Conditions for testing

Battery fully-charged, fuel in tank, engine and ambient temperatures 32-104°F (0-40°C). (The temperature has a considerable effect on the values recorded.)



## Ignition system with knock sensor

### General

Due to the variations in the fuel quality and the environmental demands, the octane rating may vary widely from one country to the next.

A fuel system incorporating a knock sensor enables the special properties of a given fuel to be utilised to achieve optimum performance and minimised fuel consumption.

Knocking will occur when the engine load is high and if the fuel is of poor quality (e.g. with a low octane rating). Knocking is the result of pre-ignition of the fuel/air mixture and may cause serious damage to the engine if it persists. In addition to the audible knocking occurring when the engine is temporarily overloaded, high-speed knocking which is inaudible to the human ear may also occur. It is this type of knocking which is most detrimental to the engine.

In order to avoid engine damage under such conditions, manufacturers have been obliged to allow generous margins to take into account the variations in fuel quality. As a result, the engine is unable to convert all of the energy in the fuel into propulsion power, and much of the energy is wasted as heat losses.

Even if a control system incorporating a knock sensor is used, the knocking occurring during normal running of the engine cannot possibly be eliminated. But this knocking is harmless to the engine.

The ignition system adjusts its timing to suit the load, the engine speed and any knocking tendencies detected.

Since the spark is always fired at the correct instant, the engine performance will always be a maximum, regardless of the fuel quality used at any particular time. This reduces the fuel consumption and minimises the pollutants in the exhaust gases.

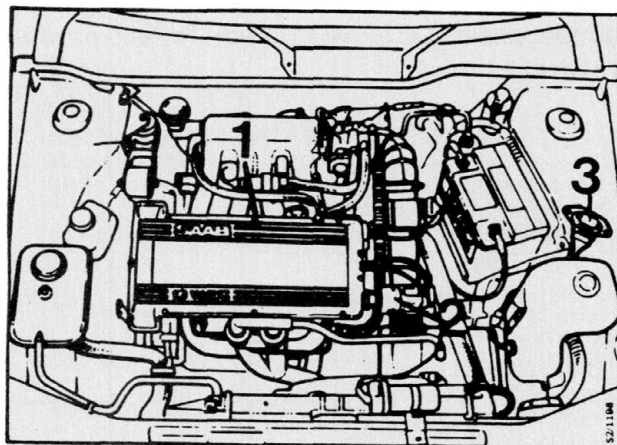

- 1 Knock sensor
- 2 Ignition distributor
- 3 Amplifier

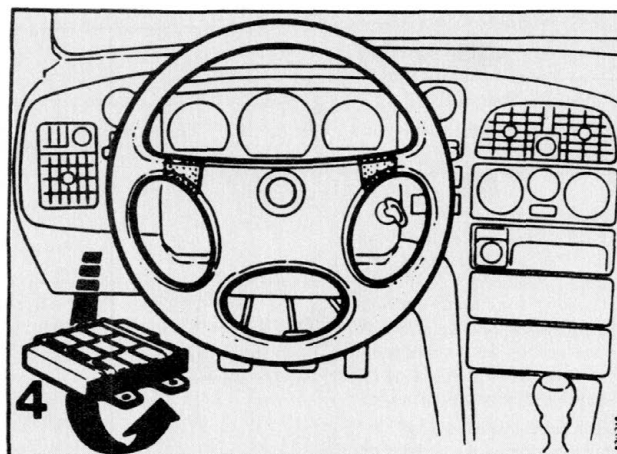

- 4 Electronic control unit

## Principle of operation

A knock sensor detects any knocking tendencies in the engine and applies a signal to the electronic control unit, which will then automatically adjust the ignition timing in accordance with the programmed parameters, and the engine load and speed input signals received.

When the engine is started, the ignition is always set to  $5^\circ$  before top dead centre (BTDC), and will remain at this value up to an engine speed of about 700 r/min. At engine speeds above 700 r/min, the system will automatically adjust the ignition timing in accordance with the data programmed into the memory of the electronic control unit. The ignition timing is set to suit the engine load, the engine speed and any knocking tendencies, and is varied between  $5^\circ$  and  $22^\circ$  BTDC.

The knocking-related ignition timing is controlled individually on each of the cylinders. The ignition timing may thus vary from one cylinder to the next.

On the other hand, the load-dependent timing is the same for all cylinders.

## Knocking-dependent control

When knocking is detected in one cylinder, the ignition for that particular cylinder will be retarded in steps of about  $3^\circ$  until knocking has ceased or until the ignition has been retarded by a total of  $13^\circ$ . The ignition timing will revert to normal in steps of  $0.35^\circ$  per speed-dependent period.

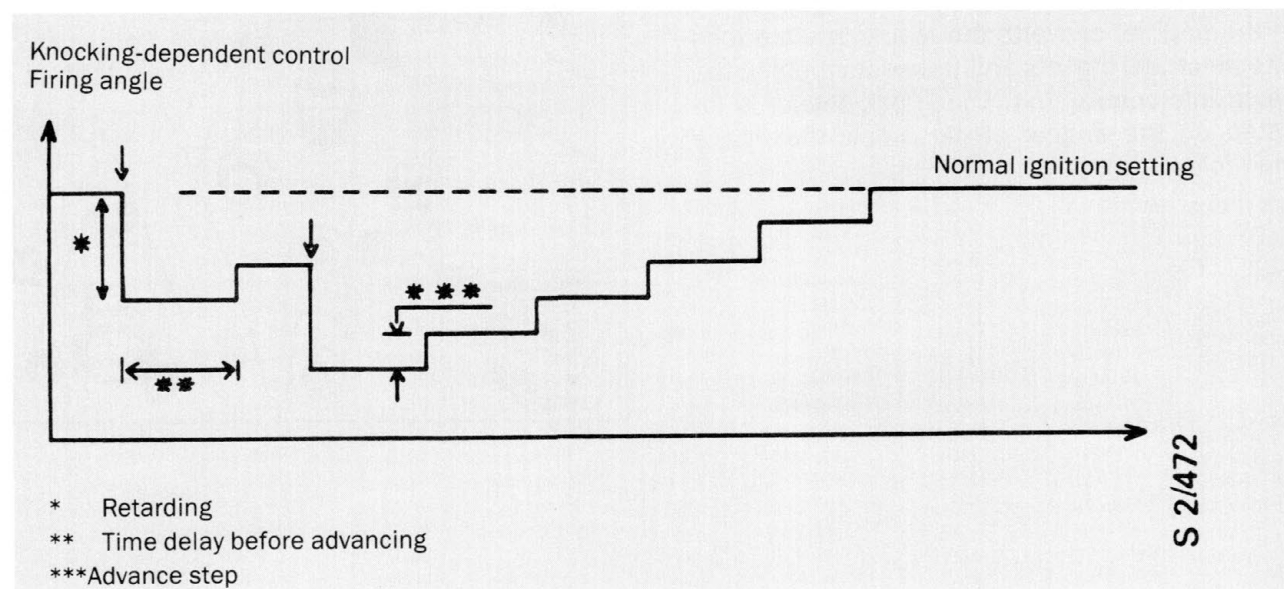

## Load-dependent control

If an engine load change should exceed the pre-determined value stored in the memory of the electronic control unit, the ignition will be retarded by about  $6^\circ$  on all cylinders simultaneously. When the load has ceased to increase, the ignition will be advanced back to the normal timing in steps of around  $1^\circ$ .

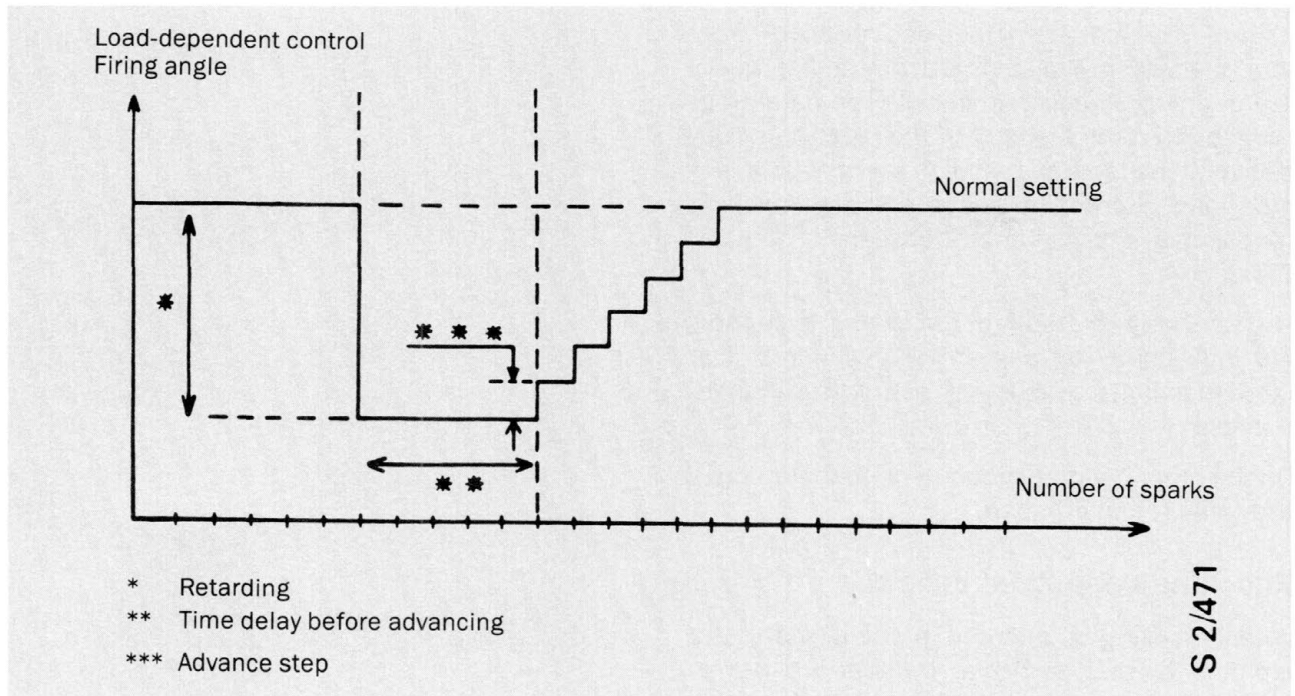

## Knock sensor

The knock sensor records any knocking occurring in the engine, converts the resulting vibrations into electrical signals and transmits them to the electronic control unit. The knock sensor is located on the engine block, below the intake manifold.

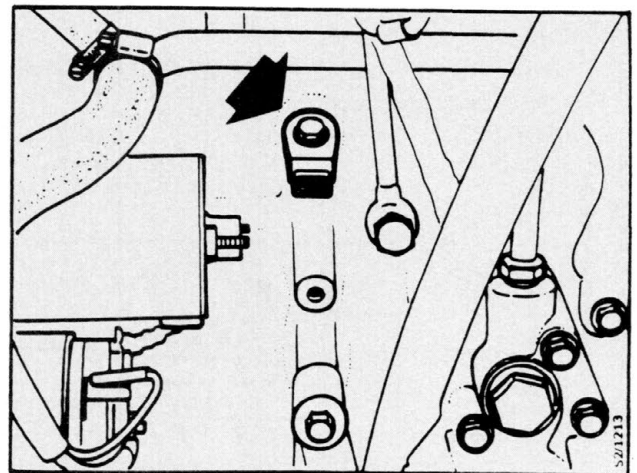

### Electronic control unit

The electronic control unit receives signals from the knock sensor, the control unit of the LH system and the Hall sensor in the distributor. The signals are analysed in the electronic control unit and are compared with the information stored in its memory. The control unit then resets the ignition timing by transmitting signals to the ignition system, which opens the primary circuit of the coil and triggers the ignition spark.

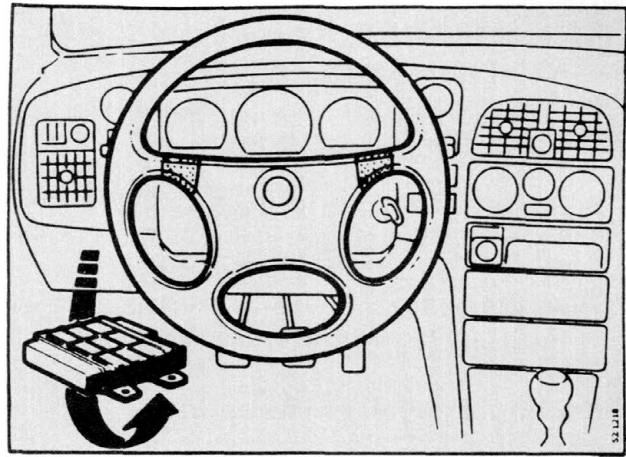

### Ignition distributor

The distributor is equipped with a Hall sensor and has no centrifugal or vacuum advance mechanism.

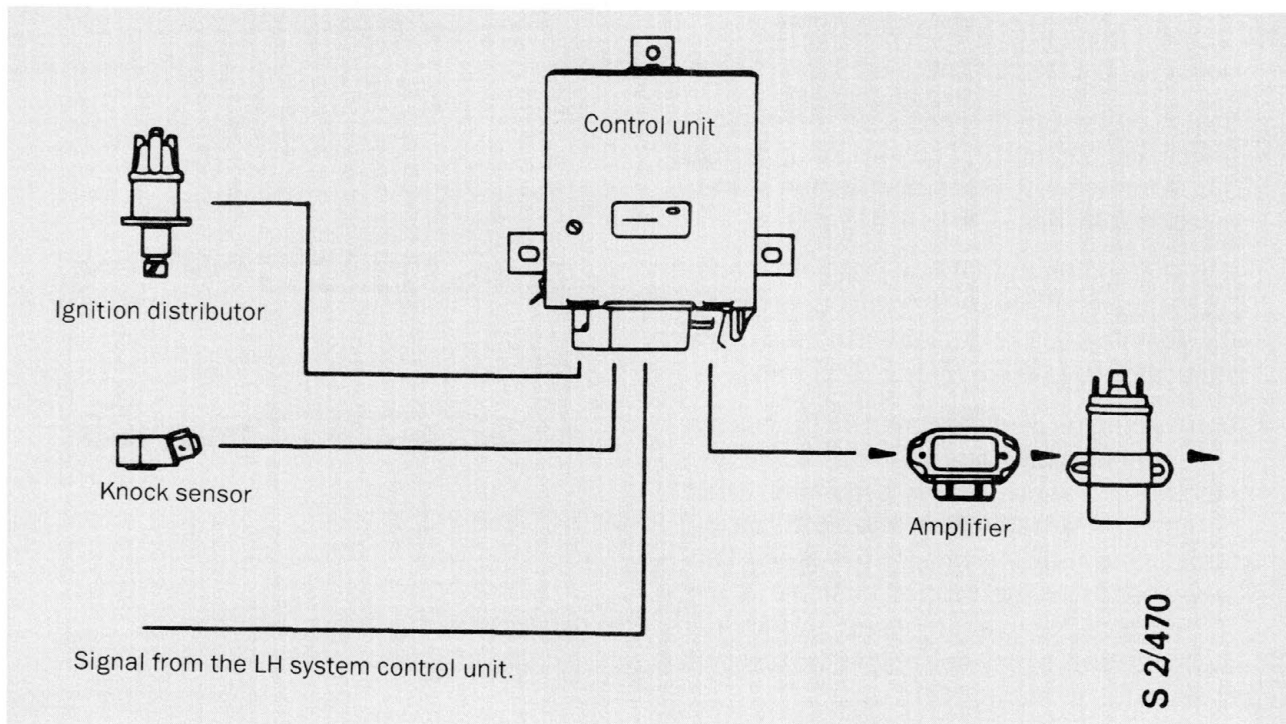

### Basic setting of the ignition timing

- 1 Start the engine and run it until it has reached normal working temperature.
- 2 Check that the idling speed is  $850 \pm 50$  r/min. Adjust as necessary.
- 3 Check that the throttle switch is closed when the throttle is in the idling position and check that the switch is correctly adjusted.



- 4 Check that the ignition timing is  $14^{\circ}$  BTDC. Adjust as necessary.
- 5 Stop the engine if the ignition timing deviates by  $7^{\circ}$  or more.
- 6 Restart the engine, let it run at idling speed and check the ignition timing again. If it still deviates by more than  $7^{\circ}$ , refer to the instructions for checking the performance of the ignition system with knock sensor.

### Functional check of the system

(This check should be carried out if maloperation is suspected, if the engine performance is poor, in the event of rough running at idling speed, and when adjusting the ignition timing.)

The system incorporates a self-diagnostic function. If this is used for the functional check, a test unit with LEDs must be connected to the test socket.

- 1 Connect test unit 83 94 058. N.B. The ignition must be switched off.
- 2 Switch on the ignition and start the engine. Check that the fault indication LED (green) is alight for about 2 seconds while the starter motor is running.
- 3 Run the engine until it has reached normal operating temperature. At some time during the warming-up period, increase the engine speed briefly to more than 2 300 r/min.
- 4 Run the engine at idling speed and check the LEDs. If the LEDs are flashing, count the number of flashes in one sequence. Then determine the fault from the fault-tracing table. (The flashing rate of the green LED corresponds to the rate of flashing of the "CHECK ENGINE" warning lamp. But knocking indication is provided only in the test unit by flashing of the red LED.)

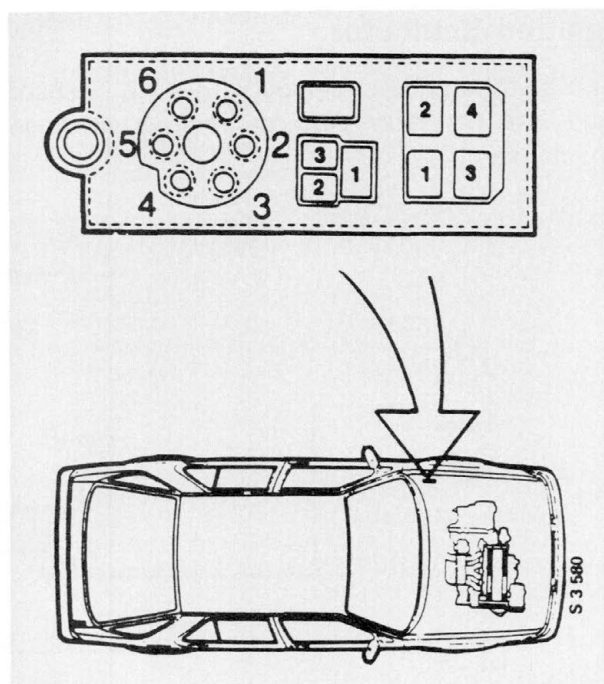

## Fault-tracing table

Number of flashes		Fault	Action
Green	Red		
1	-	Not applicable	
2	-	Not applicable	
3	-	Not applicable	
4	-	A. Knock sensor and cable	Use an ohmmeter to check the shielded cable between the knock sensor and the electronic control unit. Connect the test lead of the ohmmeter to terminals 12 and 13 of the control unit connector. N.B. Viewed from the cable side. If the circuit is in good condition, fit a new cable. If not, connect a jumper across the terminals of the knock sensor. N.B. Pull back the rubber cover and connect the jumper on the cable side. Measure between terminals 12 and 13 of the control unit connector. Fit a new cable if the circuit is open. If the circuit is not open, fit a new knock sensor.
	-	B. Inside the control unit	Fit a new control unit
5	-	Incorrect input signal from the LH system	Check the blue/red cable between terminal 24 in the connector and terminal 8 of the electronic control unit in the ignition system. (N.B. Remove the covers from the connectors and measure from the cable side.) If the cable is in good condition, fit a new LH system control unit.
	Sporadic	Indicates knocking	Normal
	Continuous	Maximum retardation	Check the engine for extreme vibrations (loose plates, broken engine mountings, etc.). Eliminate the reasons for such vibrations.

For other fault-tracing in the ignition system with Hall sensor, see page 340-16.

### To measure the voltage at amplifier terminal 5

- 1 Disconnect the amplifier connector and pull back the rubber cover.
- 2 Connect a test cable to terminal 5 on the rear of the connector.
- 3 Turn the engine so that the Hall sensor is in line with one of the openings in the slotted rotor.
- 4 Switch on the ignition and measure the voltage at the instant when the ignition is switched on. The instrument reading should be 4 - 5 V.
- 5 Switch off the ignition and turn the crankshaft so that the Hall sensor is in line with one of the solid segments of the rotor.
- 6 Switch on the ignition and measure the voltage at the instant when the ignition is switched on. This should now be below 0.1 V.

### To change the knock sensor

Tools:            Jointed extension with 13 mm socket  
                      Ratchet handle  
                      Torque spanner

### To remove

- 1 Remove the bolt holding the oil filler pipe in position and move the pipe to one side.

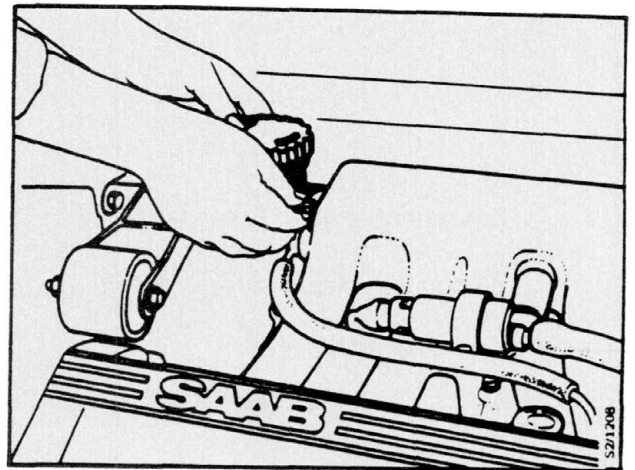

- 2 Disconnect the electric cables from the knock sensor.

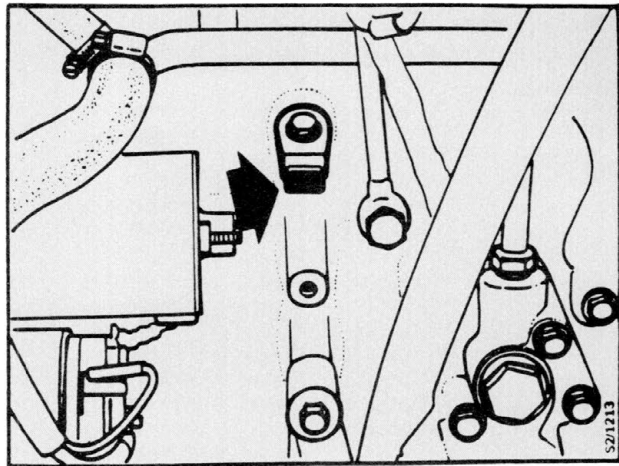

- 3 Remove the knock sensor mounting bolt. Remove the sensor from the engine block.

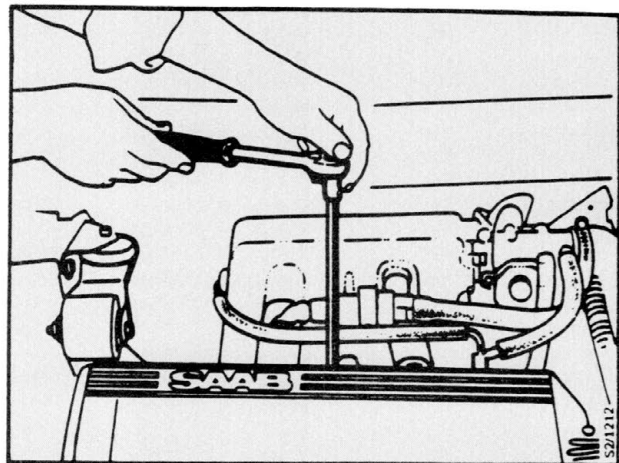

**To refit**

- 1 Clean the thread of the bolt and the contact surface on the engine block.
- 2 Hold the knock sensor in position on the block and fit the bolt.
- 3 Tighten the knock sensor bolt to a torque of 13 Nm.
- 4 Connect the electric cables to the knock sensor.
- 5 Refit the oil filler pipe retaining bolt.

# Lighting

Main lamps . . . . .	351-2	To remove the front lamp cluster . . . . .	351-27
Interior lighting . . . . .	351-3	To remove the rear lamp cluster . . . . .	351-28
Changing the bulbs . . . . .	351-5	To dismantle the headlamps . . . . .	351-30
To remove the headlamps . . . . .	351-22	Headlamp alignment . . . . .	351-32

The lighting system on the Saab 9000 comprises headlamps, front and rear lamp clusters, side direction indicator lamps, number plate illumination, interior lighting, lighting for instruments and controls, courtesy lights, and engine and luggage compartment illumination.

A high-level brake light is also fitted to cars delivered to the US and CA markets.

A pictogram incorporated into the combined instrument monitors the bulbs in the headlamps and the rear lamp clusters. The relay for the pictogram (filament monitor) is located in the electrical distribution box behind the glove compartment.

The headlamps are mounted in the front panel of the car and are fitted with removable lenses (not US, JP).

The headlamp bulbs are of two-filament type, with separate filaments for full and dipped beams.

The dip switch is incorporated into the direction-indicator stalk, located to the left, below the steering wheel. A blue warning lamp on the instrument panel will light up when the full beam is switched on.

Depending on the market specification of the car, the headlamps have either a left-hand or a right-hand asymmetric dipped beam.

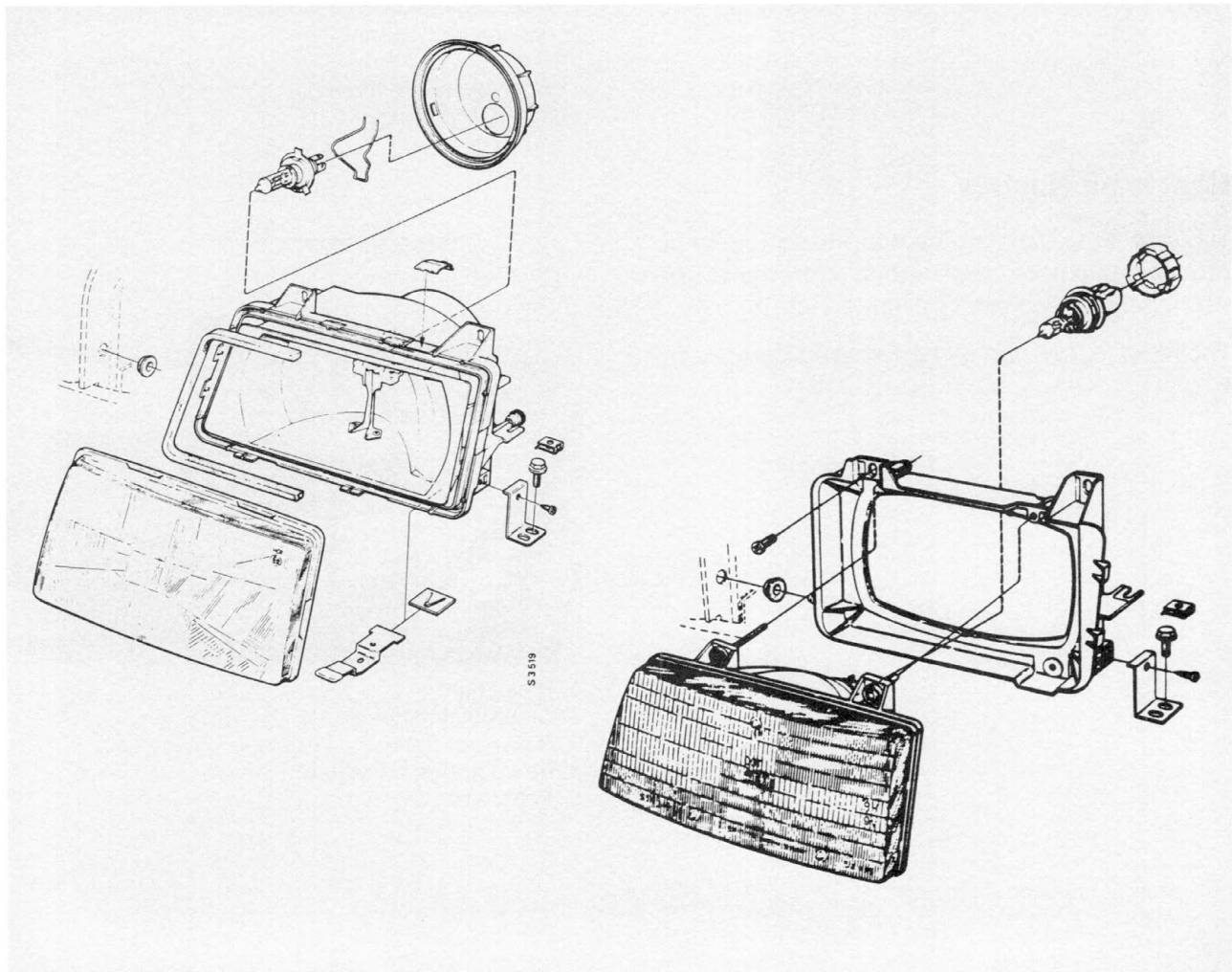

### Main lamps

Cars delivered to the GB market include a dim dipped beam feature, i.e. the dipped beam is switched on at 10% intensity, and the parking lights are also switched on.

This system includes a resistor located at the extreme front of the engine compartment on the left-hand side, and two relays in the electrical distribution box behind the glove compartment.

### Front lamp clusters

The front lamp clusters incorporate lamps for direction indicators and parking lights.

The lenses cannot be removed from the fittings.



- 1 Direction indicator/side marker light\*
- 2 Parking light/corner light\*

\* only on certain markets

### Rear lamp clusters

The rear lamp clusters incorporate lamps for direction indicators, rear lights, stop lights, reversing lights and rear fog lights (not US).

The lamp lenses cannot be removed from the fittings.



- 1 Brake light
- 2 Direction indicator
- 3 Reversing light
- 4 Rear light/Rear fog light
- 5 Rear light

**High-level brake light (US, CA).**

The high-level brake light is located in the centre of the rear window, at the bottom edge.

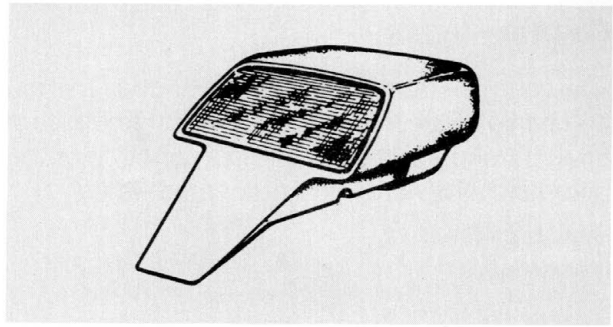
**Side direction indicator lamps**

A side direction indicator lamp is fitted towards the rear of each front wing.

**Number-plate illumination**

The number-plate illumination consists of two lamps located one on either side of the handle for the luggage compartment lid.

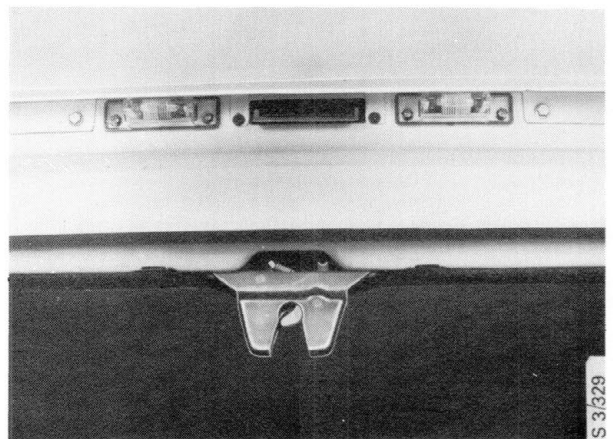
**Interior lighting**

The interior lighting consists of a lamp in the centre of the roof, a lamp in the inner rear-view mirror, a swivelling spotlight in the roof console and a fixed reading lamp on each of the rear pillars.

The interior lighting is wired through a time-delay relay and will therefore remain alight for about 15 seconds after the doors have been closed or until the ignition has been switched on.



### **Courtesy lights**

The courtesy lights fitted to every door are designed so that a white light illuminates the door opening and a red light on the rear edge of the door acts as a warning to other road-users.



### **Engine compartment illumination**

The engine compartment lamp is fitted to the bonnet and is operated by a built-in mercury switch.

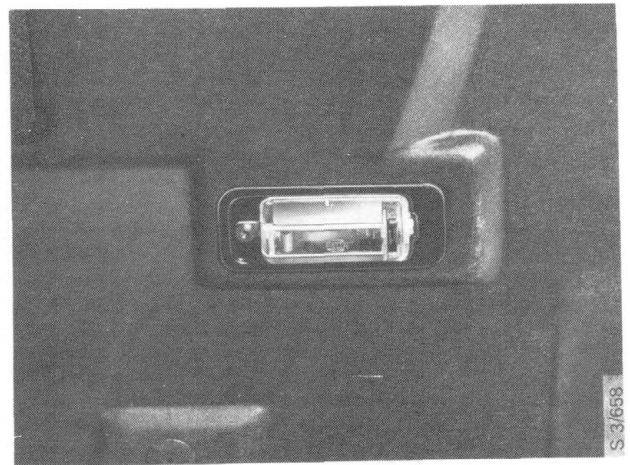

### **Luggage compartment illumination**

The luggage compartment lamp is fitted on the right-hand side in the luggage compartment and is operated by a mercury switch in the luggage compartment lid.



### **Lighting for instruments and controls**

Several lamps are provided for lighting up the instruments, the heater control panel, the ashtray, the glove compartment and certain controls.



## Changing the bulbs

### Headlamps (not US, JP)

---

**N.B.**

Don't fit 100 W bulbs, since the reflector may melt.

---

- 1 Open the bonnet and remove the cover from the rear of the headlamp fitting.

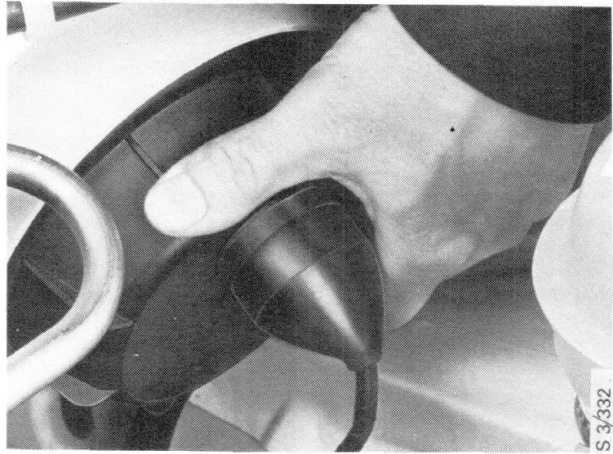

- 2 Disconnect the connector from the lamp fitting.



- 3 Pull back the spring clip.

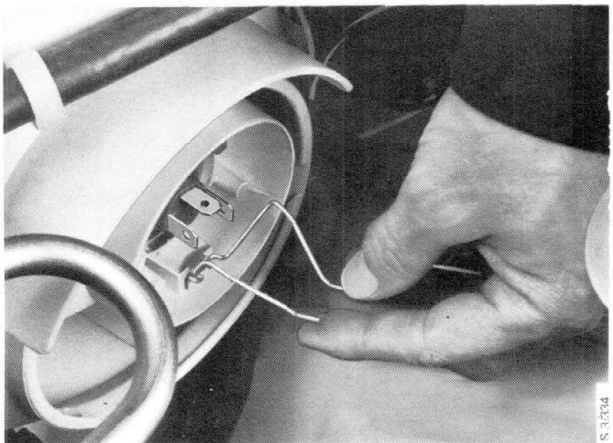

## 351-6 Lighting

---

- 4 Fit a new bulb. Don't touch the glass of the bulb with your fingers. Make sure that the three locating lugs are in the right positions.
- 5 Fit the spring clip, making sure that it is correctly located.
- 6 Fit the connector and fit the cover.

### Headlamps (US, JP)

- 1 Open the bonnet and remove the bulb socket.

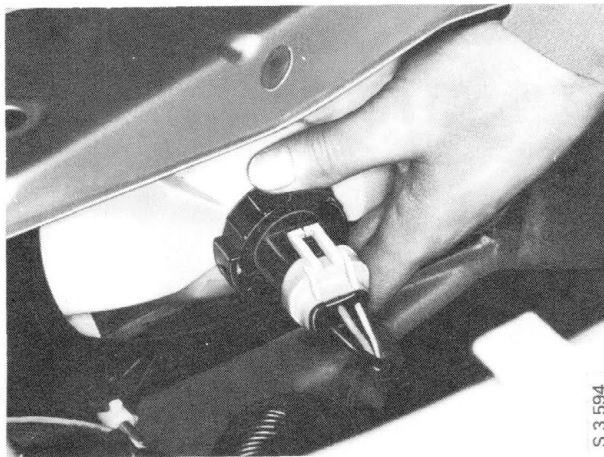

S 3 594

- 2 Remove the bulb.

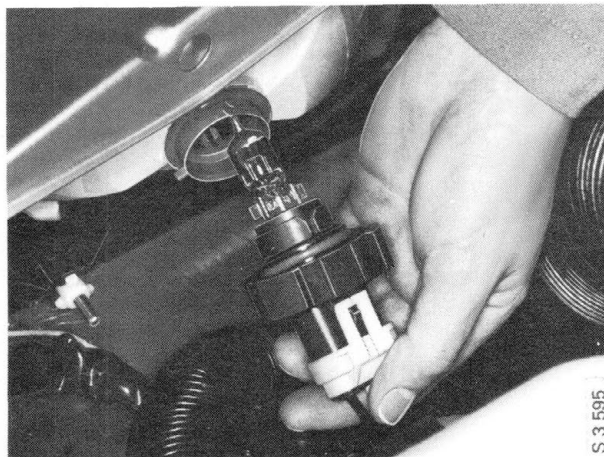

S 3 595

- 3 Fit a new bulb. Don't touch the glass of the bulb with your fingers.
- 4 Fit the bulb socket.

### Front lamp clusters

- 1 Twist and remove the bulb socket.

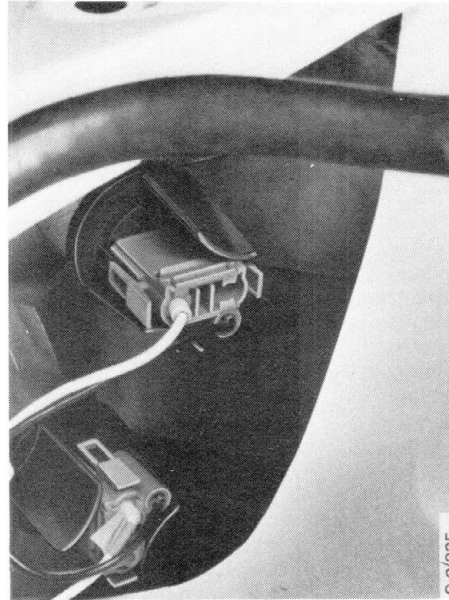

- 2 Withdraw the bulb socket and change the bulb. Don't touch the glass of the bulb with your fingers.
- 3 Refit the bulb socket, and twist it to secure it.

### Rear lamp clusters

- 1 Disconnect the connector.

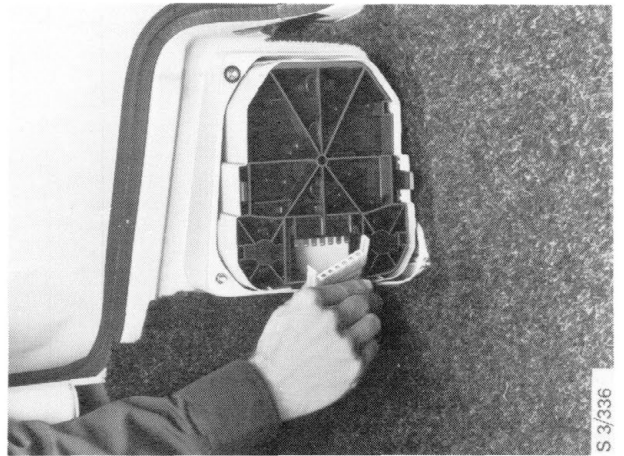

- 2 Depress the catches and withdraw the bulb socket.



- 3 Change the bulb. Don't touch the glass of the bulb with your fingers.

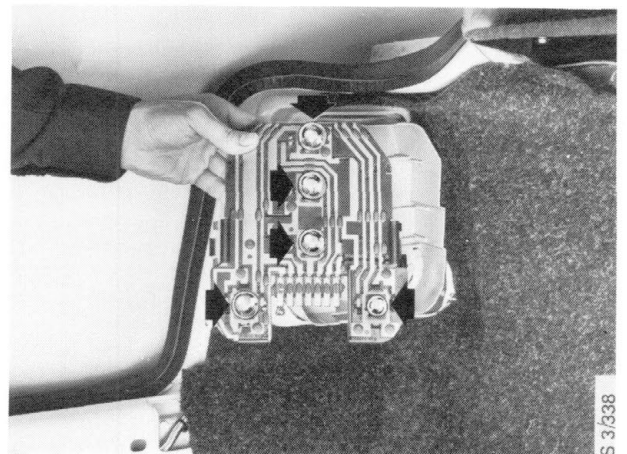

- 4 Insert the bulb socket and connect the connector.

### High-level brake light (US, CA)

Pull down the bulb socket and change the bulb.

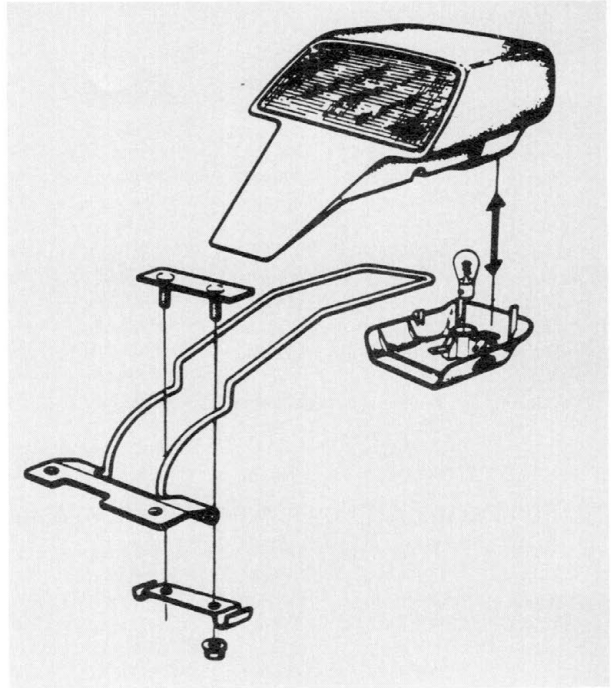

### Side direction indicator lamps

- 1 Push the lamp housing forward slightly and remove it.

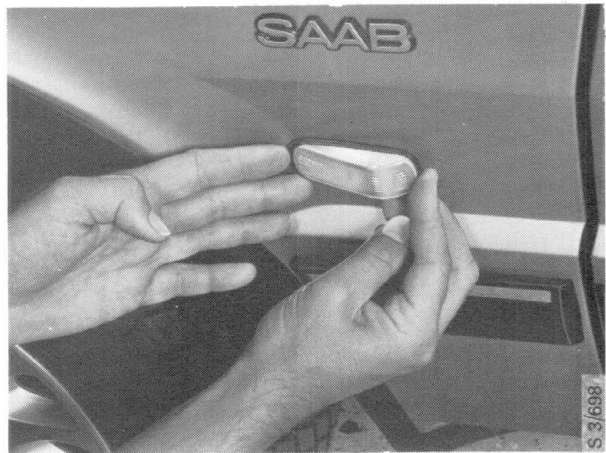

- 2 Remove the bulb socket and change the bulb.

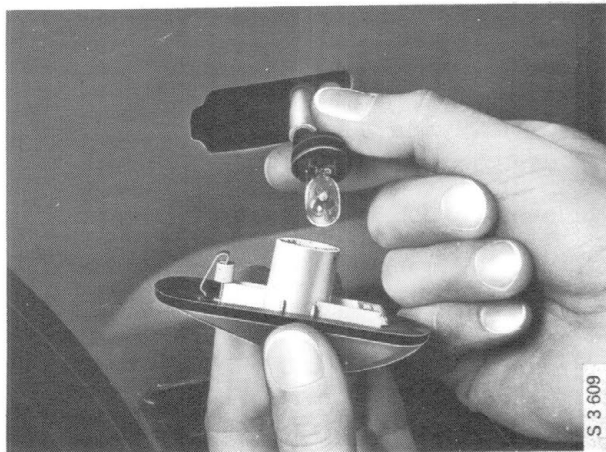

## Number plate illumination

- 1 Remove the screws.

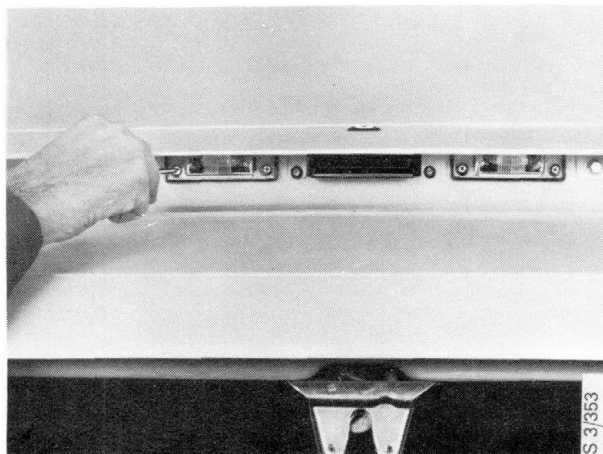

- 2 Pull the lamp fitting forward and change the bulb.

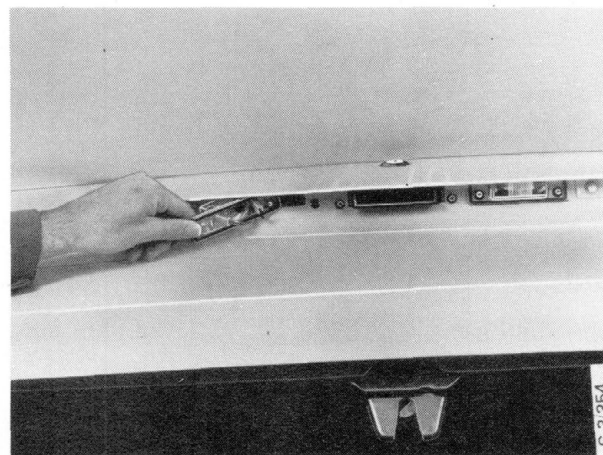

## Roof lamp

- 1 Remove the lens.

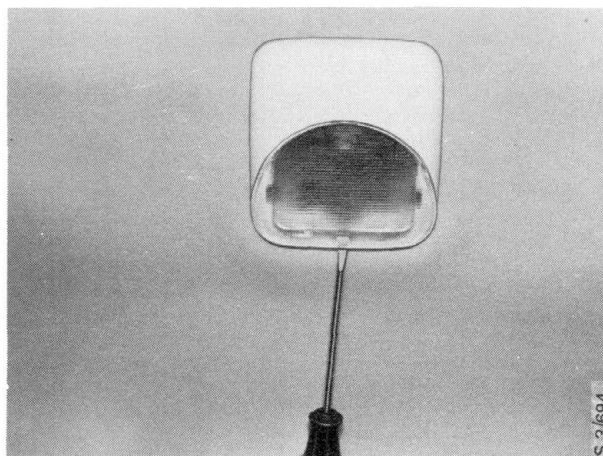

On cars with sunroof, pull down the rear edge of the lamp fitting to release it.

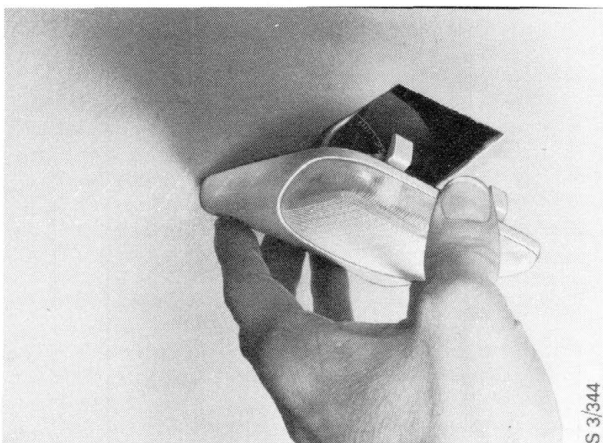

2 Change the bulb.

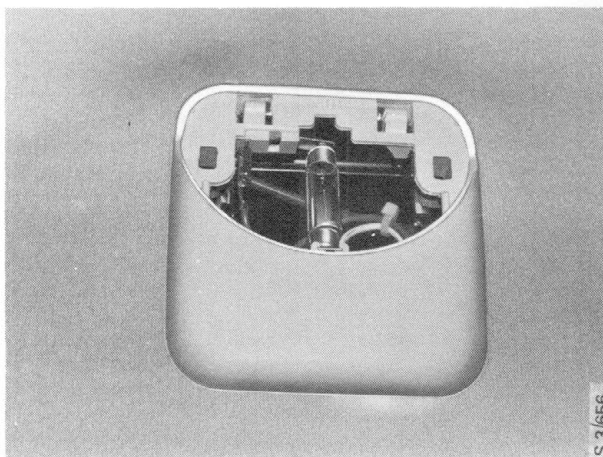

### Lamp in the inner rear-view mirror

1 Remove the lens.

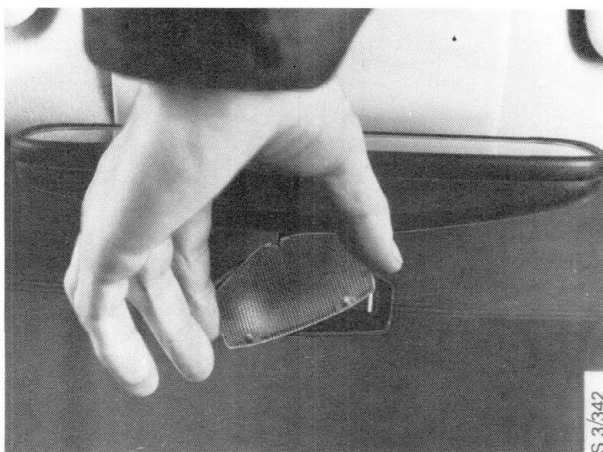

2 Change the bulb.

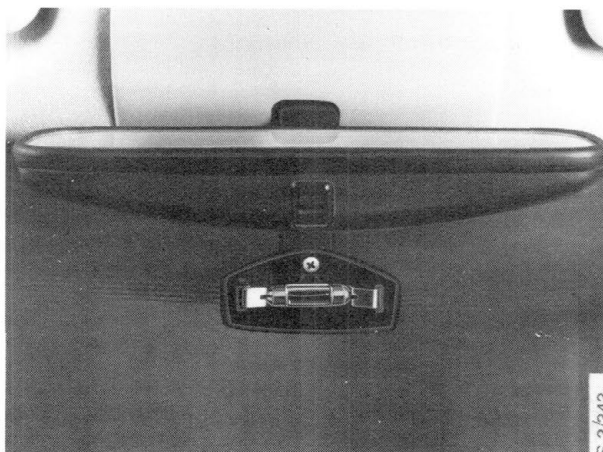

### Spotlight in roof console

1 Remove the screw and remove the cover.

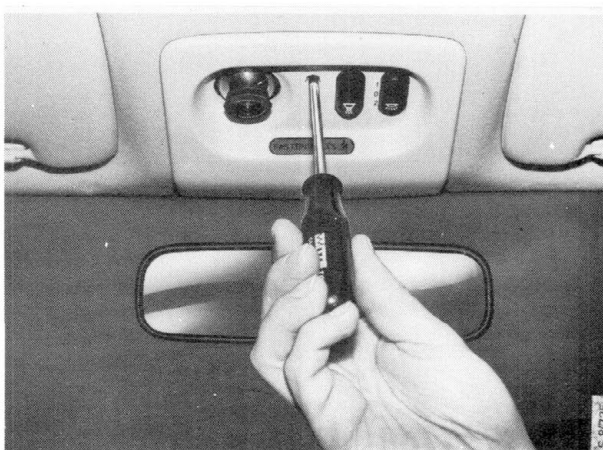

## 351-12 Lighting

On cars with sunroof, the screw is located behind a plastic cover.

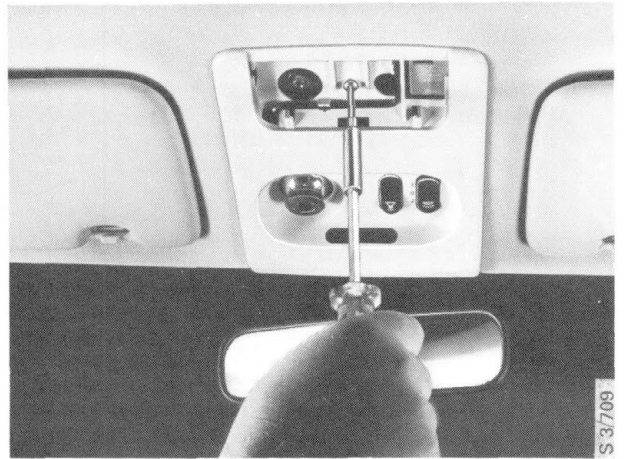

2 Remove the three screws retaining the lamp.

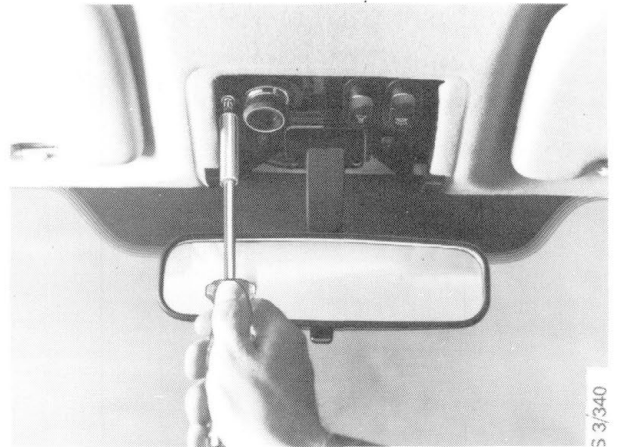

3 Change the bulb.

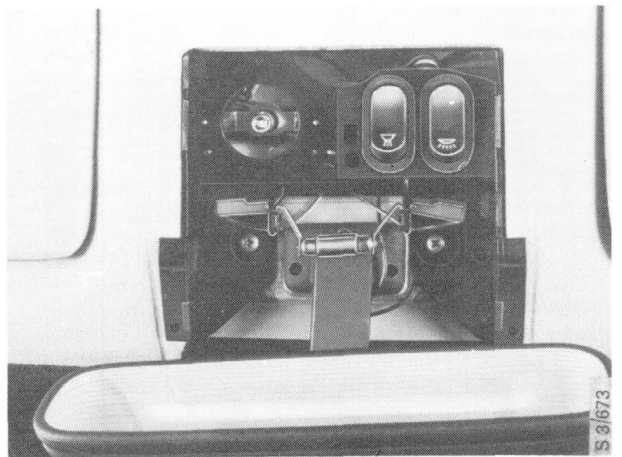

### Rear reading lamp

1 Withdraw the lamp fitting by pulling the front edge.

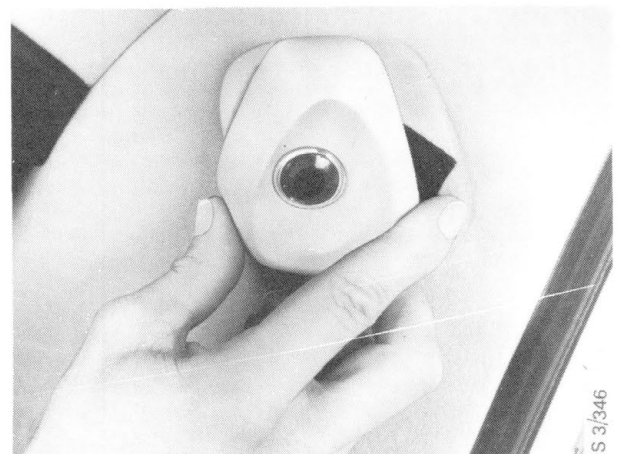



- 2 Remove the lamp fitting.

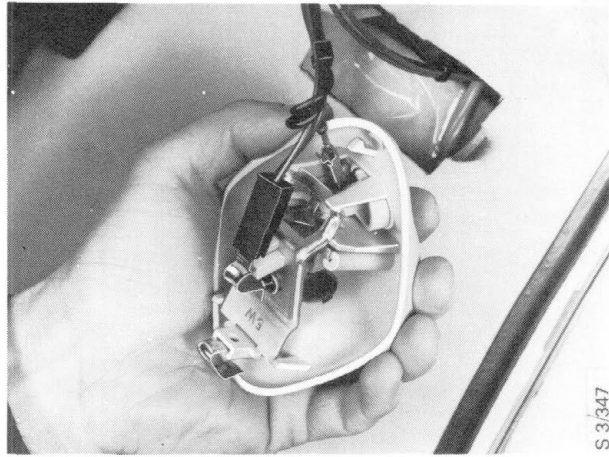

- 3 Press back the catches.
- 4 Lift out the bulb socket and change the bulb.

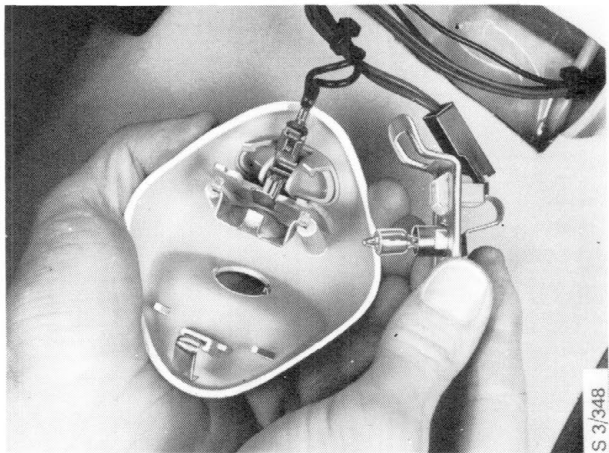

### Combined instrument and clock

Instructions for changing the bulbs are given in Section 381 "Instruments".

### Heater control panel (cars not equipped with ACC).

- 1 Pull off the knobs.

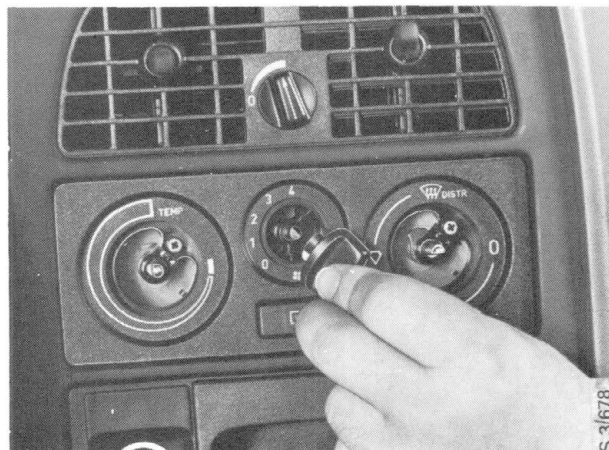

## 351-14 Lighting

2 Remove the screws.

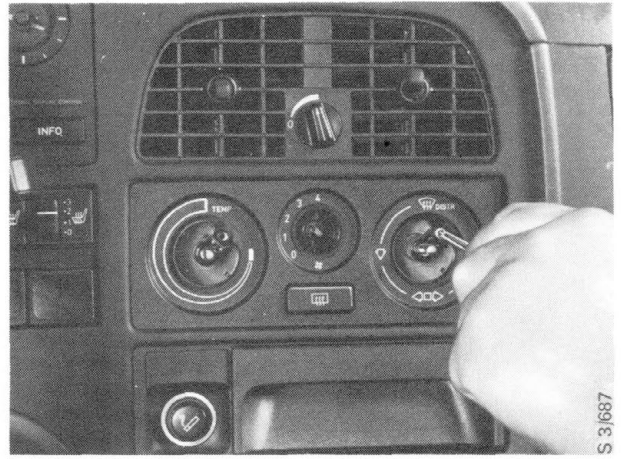

3 Remove the front panel.

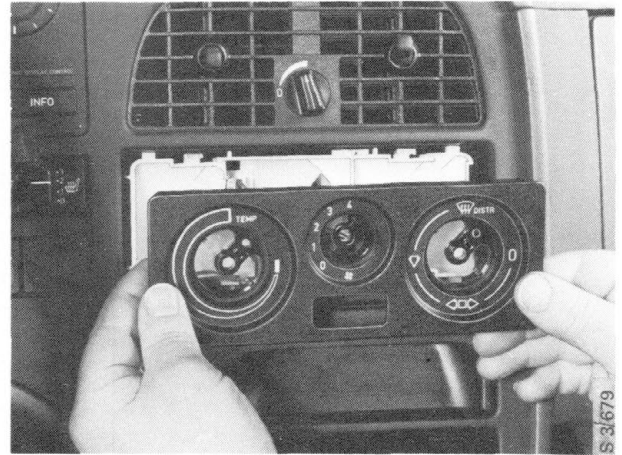

4 Pull the defective bulb out of its holder and change it.



### Heater control panel (cars equipped with ACC)

1 Remove the ashtray.



- 2 Bend down the two upper locking tabs and withdraw the ashtray holder forward.

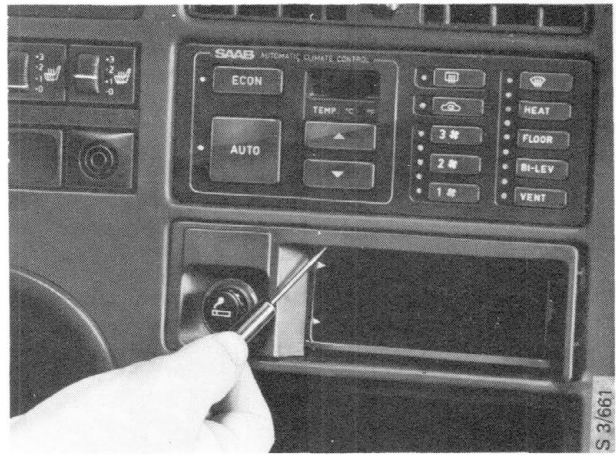

- 3 Press out the control panel and pull it forward.



- 4 Use a screwdriver to remove the bulb with its socket.

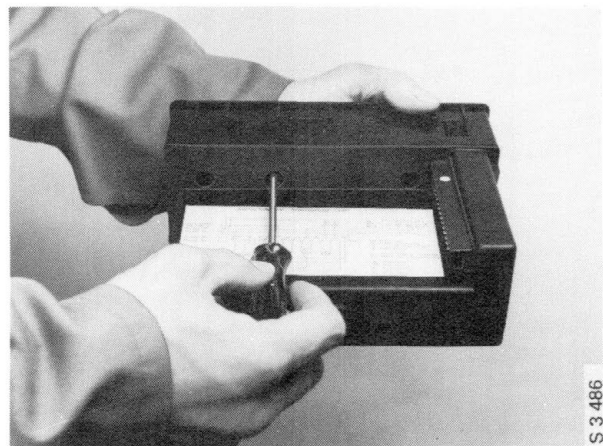

## 351-16 Lighting

5 Fit a new bulb and twist it to secure it.

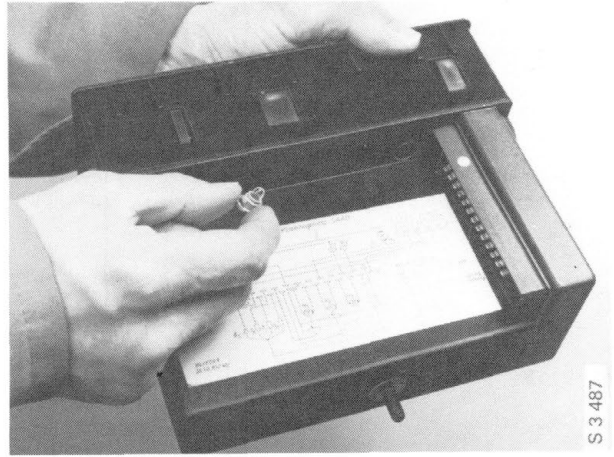

6 Press in the control panel and fit the ashtray.

### Ashtray and cigarette lighter

1 Remove the ashtray.



2 Bend down the two upper locking tabs and withdraw the ashtray holder forward.



3 Change the bulb.

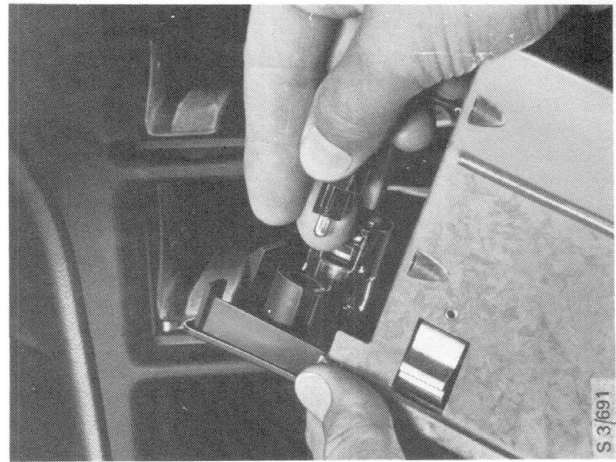

### Glove compartment lamp

1 Remove the lens.

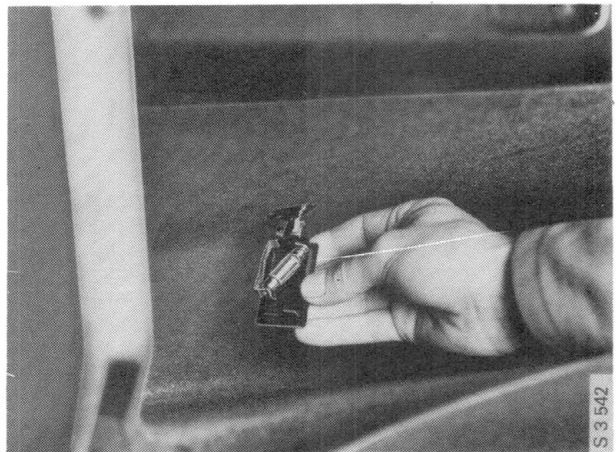

2 Change the bulb.

### Storage compartment between the front seats

1 Remove the lens.



2 Change the bulb.

### Lighting for the selector lever scale (only cars with automatic transmission)

1 Remove the two screws.

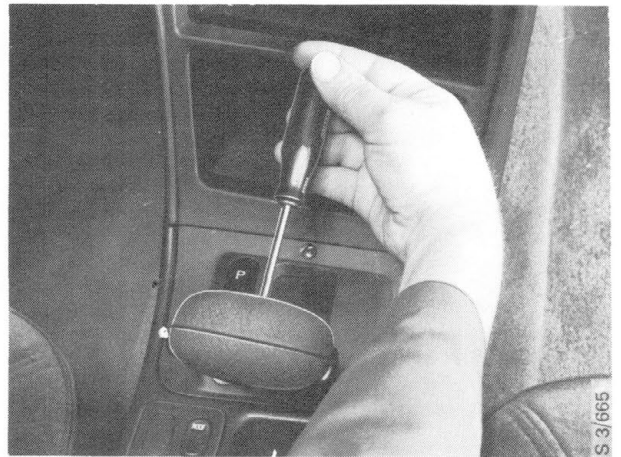

2 Remove the front cover.

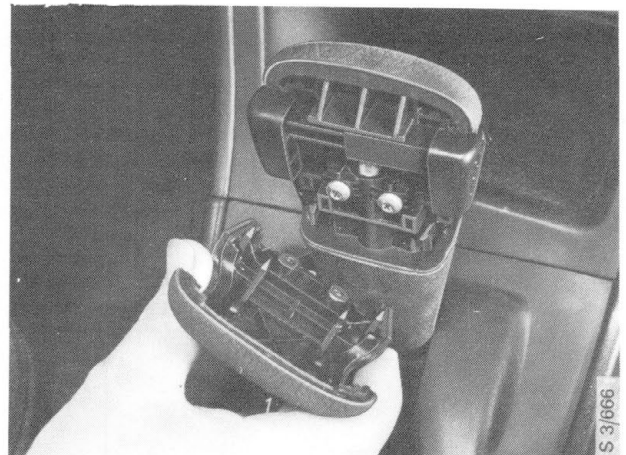

3 Remove the latch mechanism.



4 Remove the two screws and pull up the selector lever housing.



- 5 Remove the screw for the selector lever cover and remove the cover.
- 6 Change the bulb.

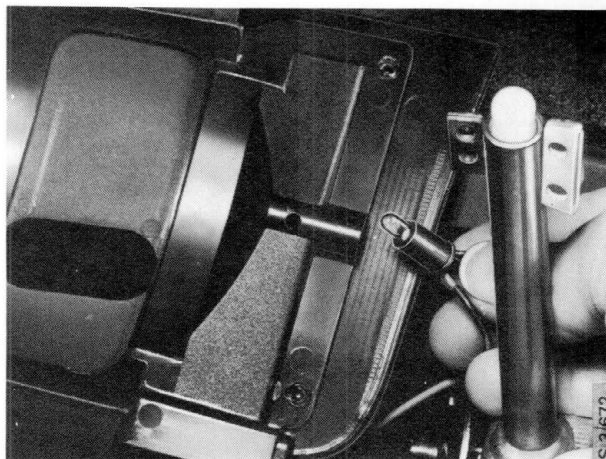

- 7 Assemble in the reverse order.

### Seat belt warning

- 1 Remove the screw and remove the cover.

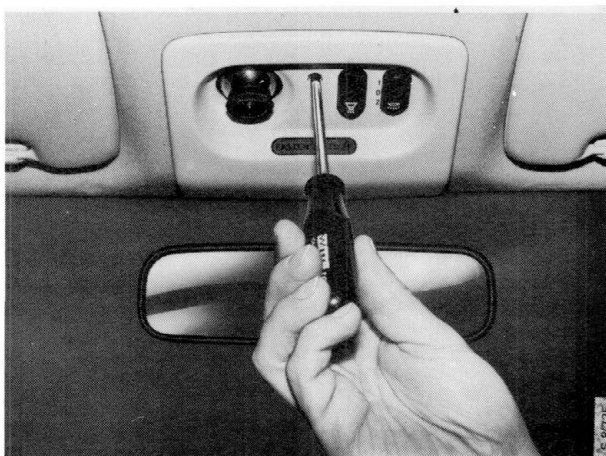

On cars with sunroof, the screw is located behind a plastic cover.

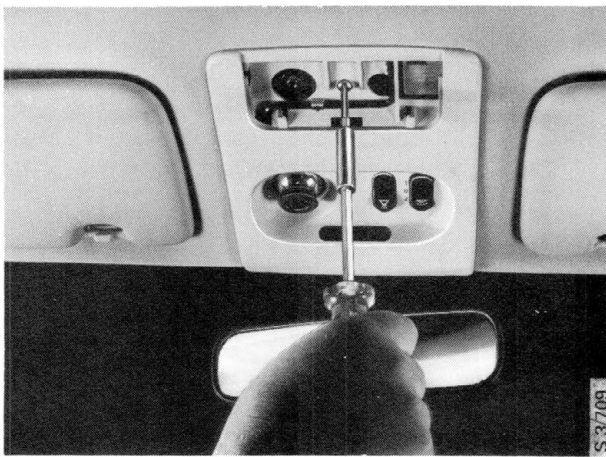

- 2 Change the bulb.

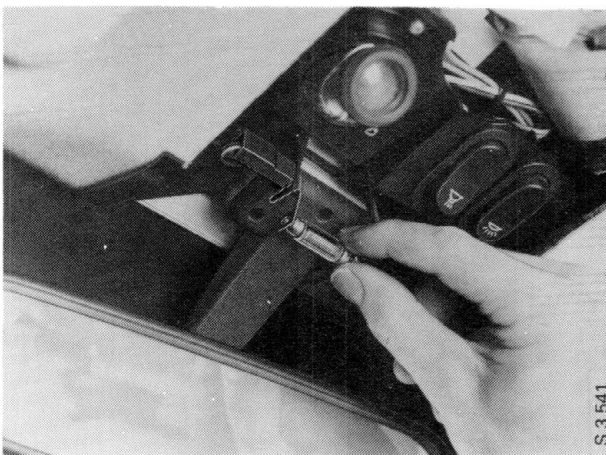

### Courtesy lights

- 1 Remove the screw.

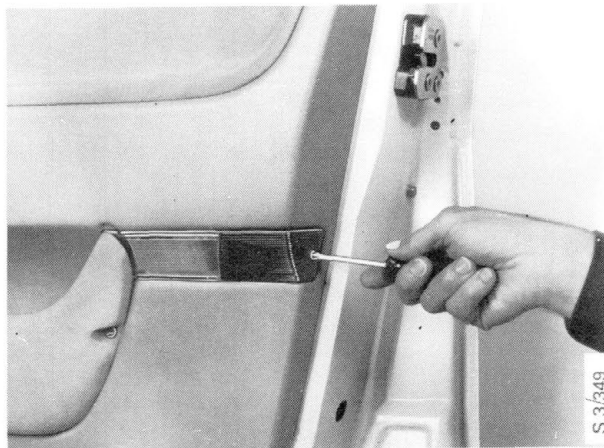

- 2 Lift off the lamp fitting and change the bulb.



### Engine compartment lamp

- 1 Remove the screw.
- 2 Pull the lamp fitting forward and change the bulb.





## Luggage compartment lamp

- 1 Remove the screws.

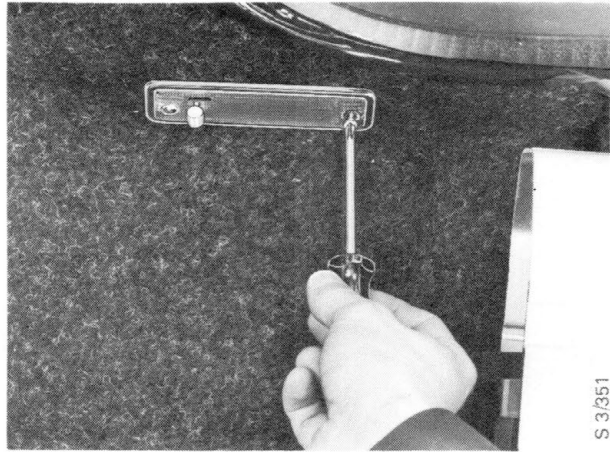

- 2 Lift off the lamp fitting and change the bulb.

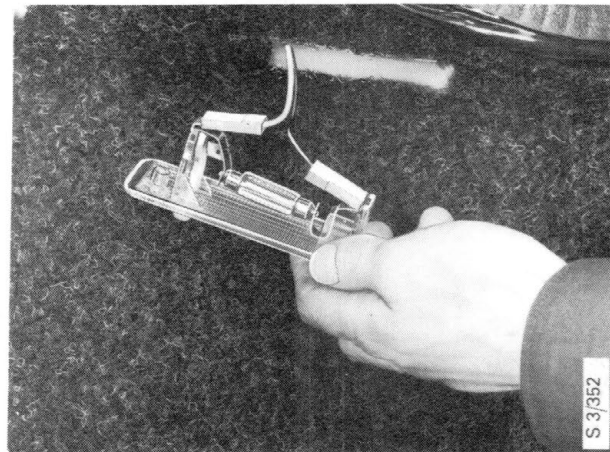

## Headlamps

### To remove (not US, JP)

- 1 Disconnect the negative (-) battery cable.

#### **N.B.**

**Never** disconnect the battery when the engine is running, since serious damage to the alternator may result.

- 2 Remove the screws securing the lamp cluster.

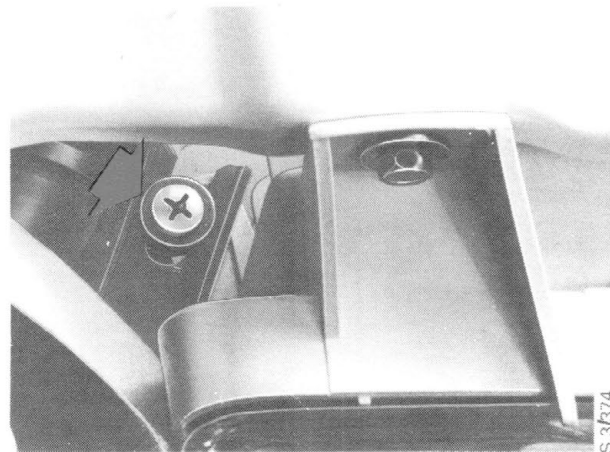

## 351-22 Lighting

3 Ease out the front edge of the fitting slightly.

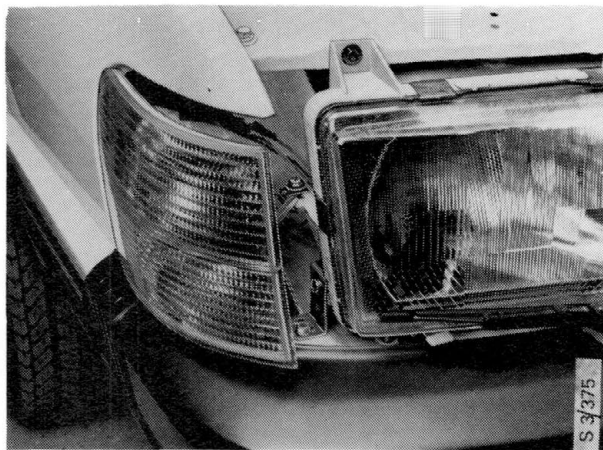

4 Remove the cover from the rear of the headlamp and disconnect the connector for the bulb and the wiper motor.

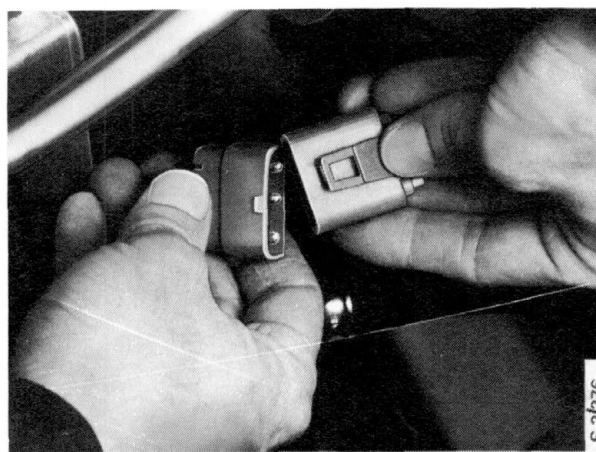
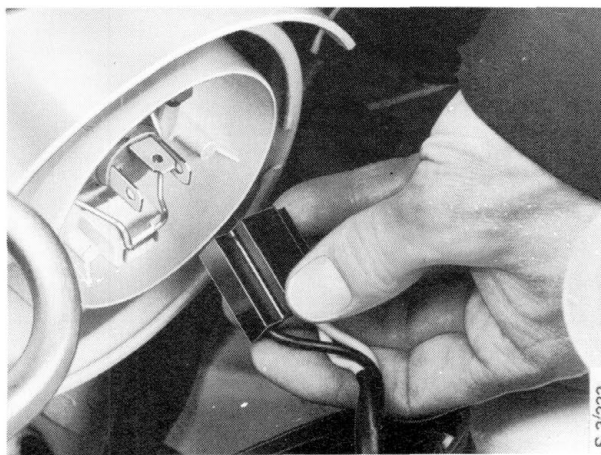
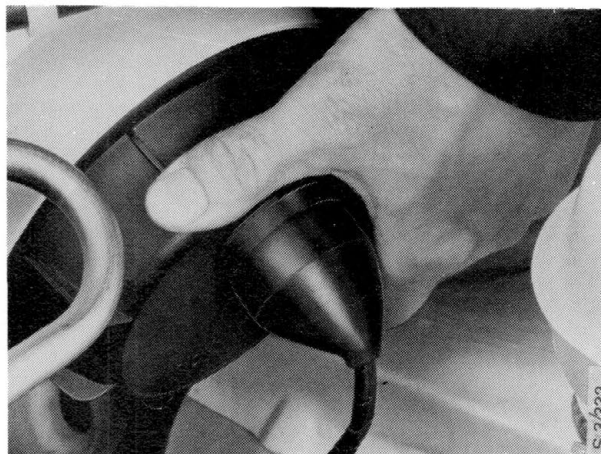

5 Disconnect the washer hose at the wiper blade.



6 Remove the bottom retaining screw for the headlamp.

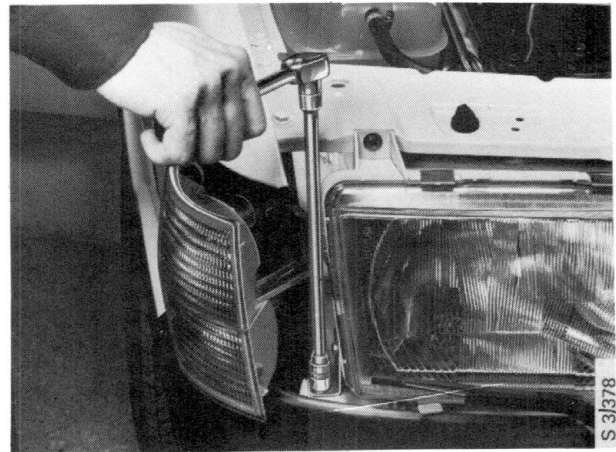

7 Remove the two top retaining screws.



8 Ease the headlamp slightly sideways, towards the wing, to release it from its inner clip. Remove the headlamp by lifting it diagonally upwards.

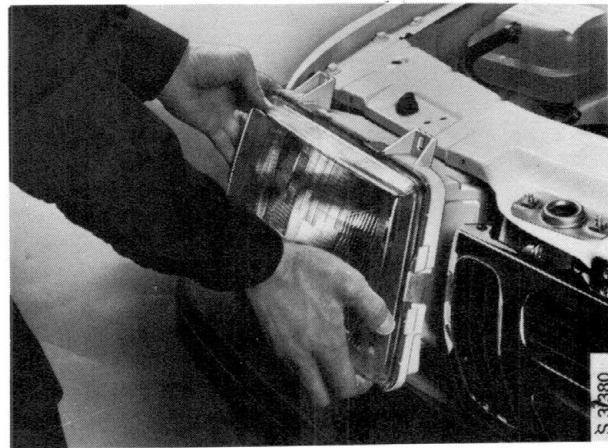

### To remove (US, JP)

- 1 Disconnect the negative (-) battery cable.

---

#### **N.B.**

**Never** disconnect the battery when the engine is running, since serious damage to the alternator may result.

---

- 2 Remove the screws securing the lamp cluster.

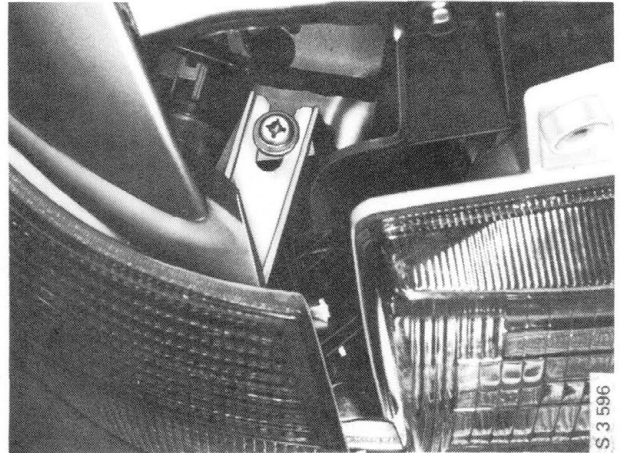

- 3 Ease out the front edge of the fitting slightly.

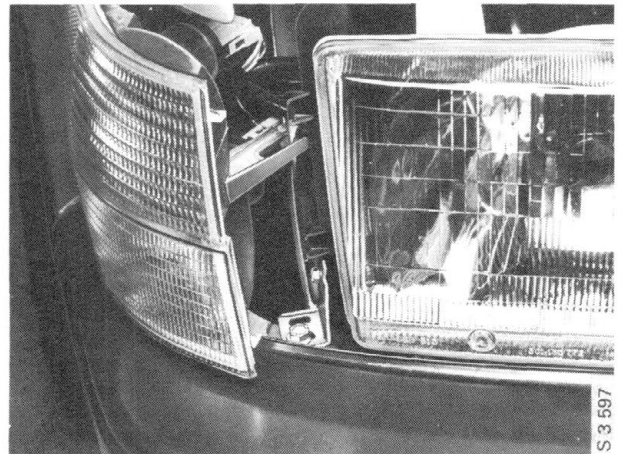

- 4 Release the bulb socket.

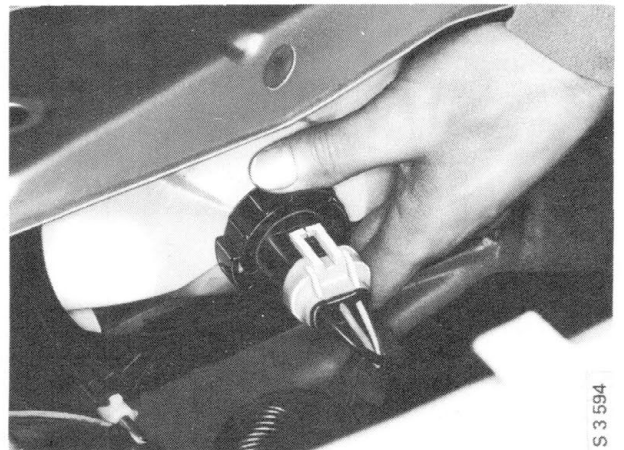

6 Remove the two top retaining screws.

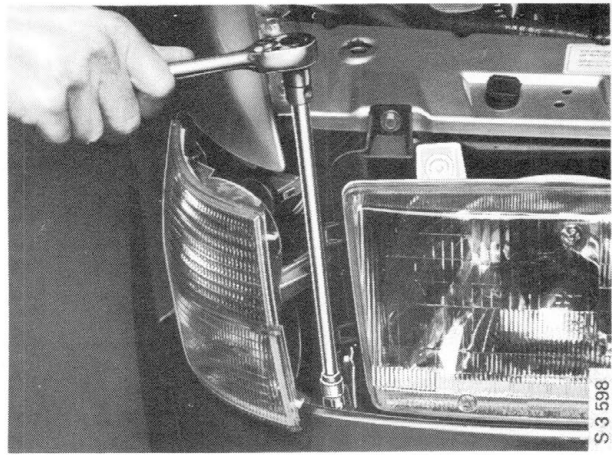

5 Remove the bottom retaining screw for the headlamp.

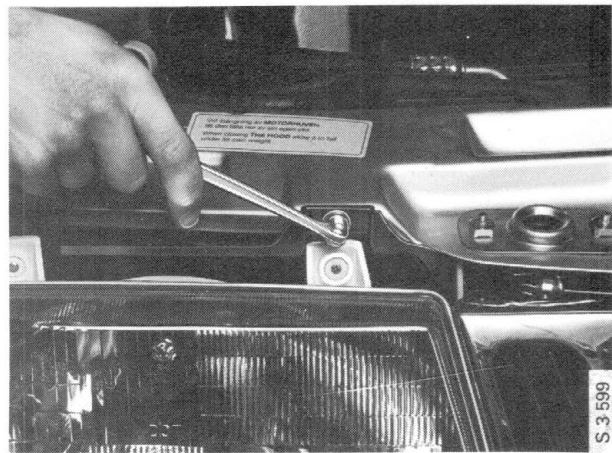

7 Move the headlamp slightly sideways, towards the wing, to release it from its inner clip. Remove the headlamp.



**To fit**

Refit in the reverse order.

Check the headlamp alignment after refitting the headlamp.

## Front lamp cluster

### To remove

- 1 Disconnect the negative (-) battery cable.

---

#### **N.B.**

**Never** disconnect the battery when the engine is running, since serious damage to the alternator may result.

---

- 2 Mark the electric cables in the lamp cluster and disconnect them.

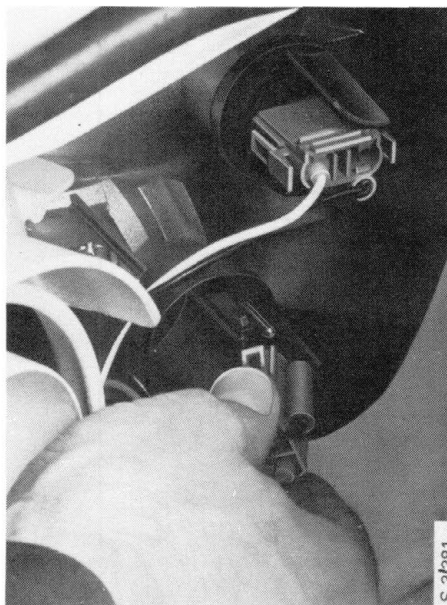

- 3 Remove the front retaining screw.

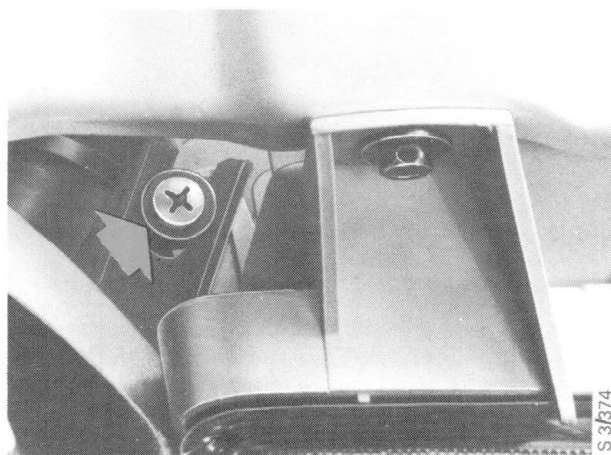

- 4 Pull the fitting forwards and withdraw it from its rear mountings (rubber bushes).

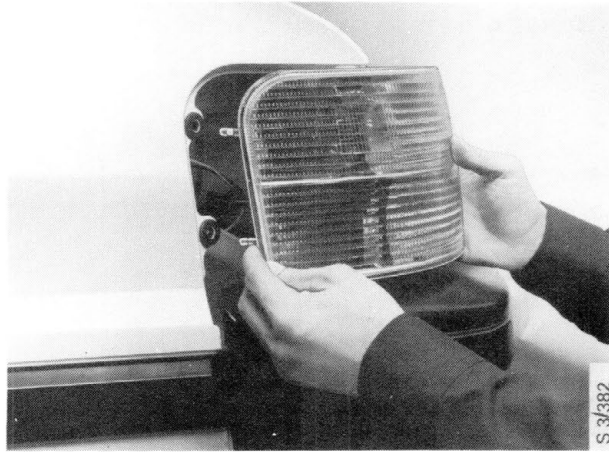

**To fit**

Refit in the reverse order

**Rear lamp cluster**

**To remove**

- 1 Disconnect the negative (-) battery cable.

---

**N.B.**

**Never** disconnect the battery when the engine is running, since serious damage to the alternator may result.

---

- 2 Disconnect the connector.

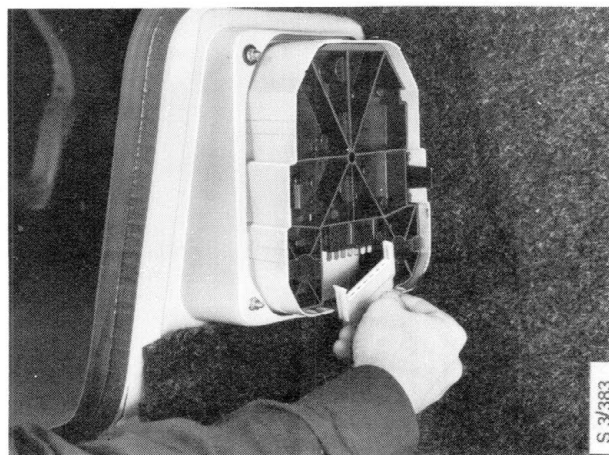

## 351-28 Lighting

3 Remove the four securing nuts.

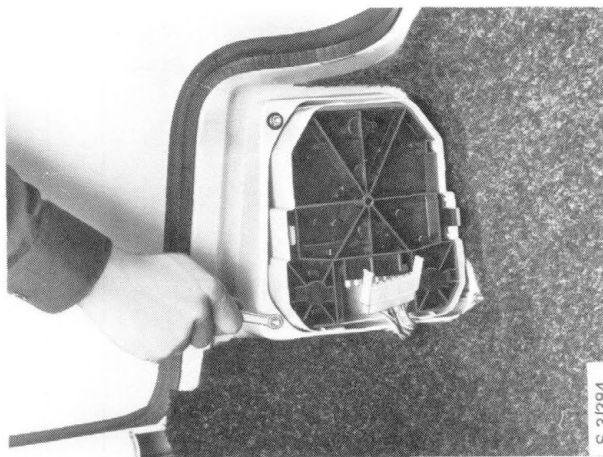

4 Lift out the lamp cluster.

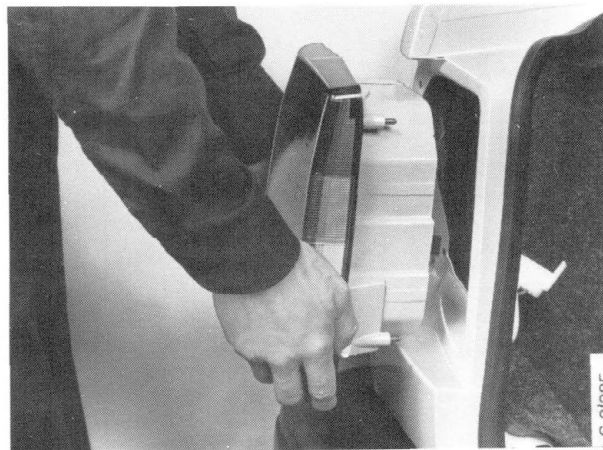

### **To fit**

Refit in the reverse order.



## Headlamps

### To dismantle (not US, JP)

- 1 Remove the wiper arm and the wiper motor securing screw, and withdraw the motor from its mounting.

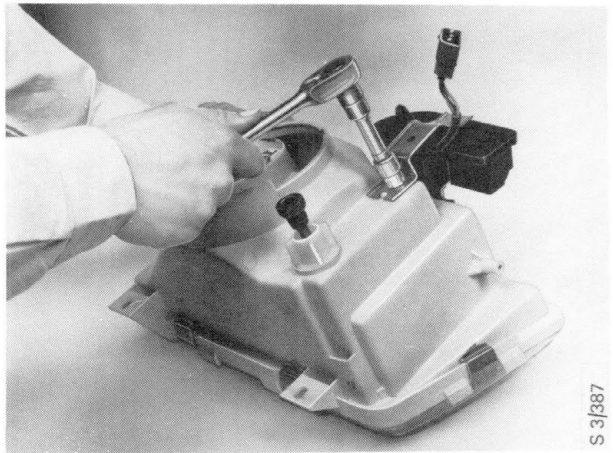
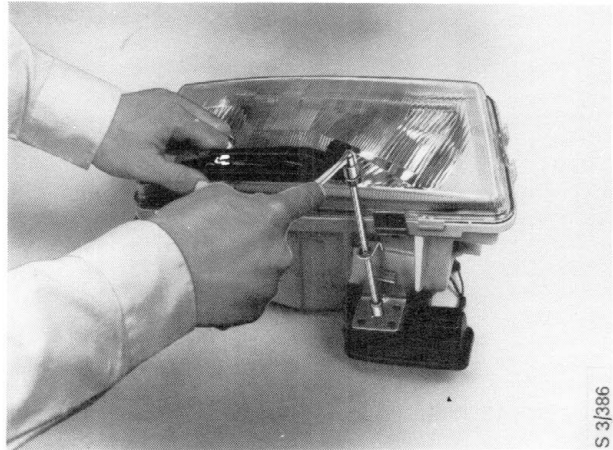

- 2 Remove the bulb.

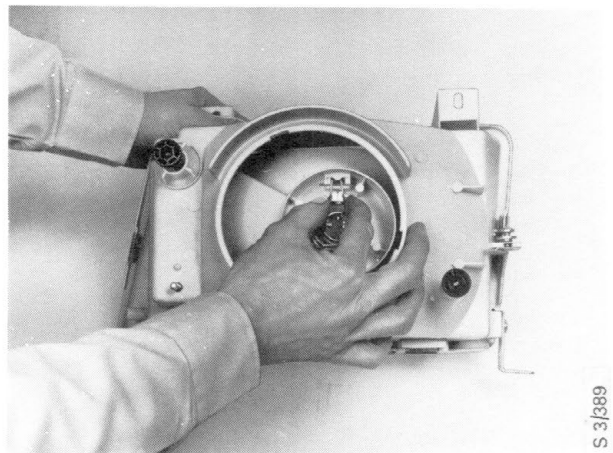

## 351-30 Lighting

- 3 Remove the six clips. Lever gently against the headlamp housing and not against the glass.

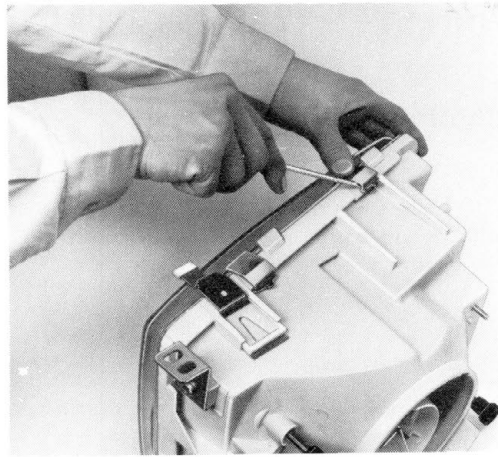

S 3/390

- 4 Remove the lens complete with gasket.

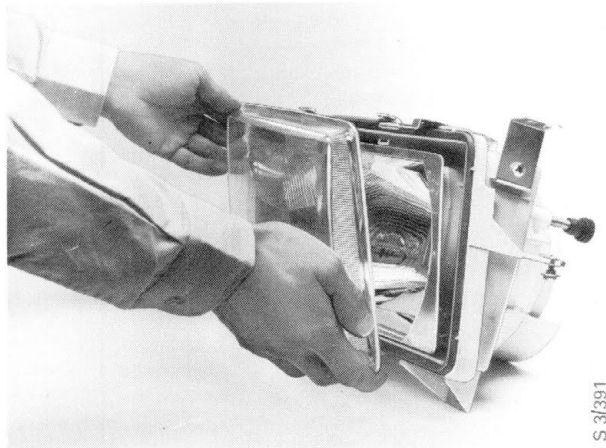

S 3/391

- 5 Fit the new gasket carefully to ensure a watertight joint.

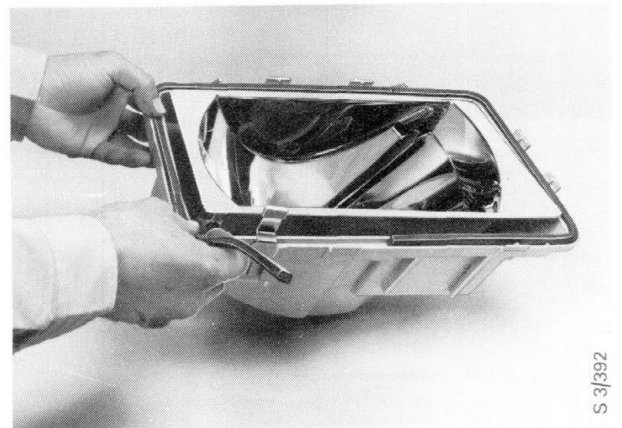

S 3/392

### **To assemble**

Re-assemble in the reverse order.

After re-assembling and refitting the headlamp, check the headlamp alignment.

## Headlamp alignment (not US, JP)

Align the headlamps using special aligning equipment.

- 1 Open the bonnet.
- 2 Adjust the headlamps by means of the two adjusting knobs on the rear of the headlamp housing.

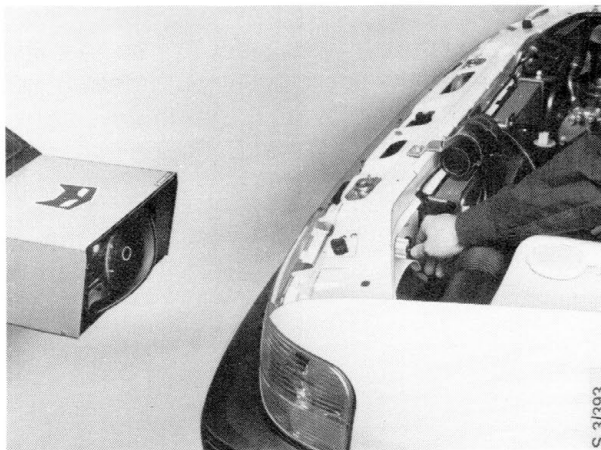

Align as follows:

- Check the tyre pressures, load the car as it would normally be loaded and position the car at right-angles to the headlamp aligning unit.
- Set the lens of the aligning unit to the correct height in relation to the headlamp and to the correct lateral position in relation to the asymmetric part of the headlamp lens.

---

### **N.B.**

If the lateral position of the aligning unit is set incorrectly, the entire alignment may be incorrect.

---

- a If suspended alignment equipment is used:  
Position the car with the left-hand wheels along the reference line. The distance of the front and rear wheels from the line must not differ by more than 3 cm.
- b If alignment equipment with a light aperture is used:  
Position the equipment in front of the headlamp, switch on the lamp in the aperture and turn the unit until the beam strikes the same point on both wings (measured from the front of the wing).

---

### **N.B.**

Always follow the manufacturer's instructions for the headlamp alignment equipment.

---

## 351-32 Lighting

Switch the headlamps to dipped beam.

- a Adjust the height of the beam to the left-hand\* horizontal line. Adjust only that part of the light/dark boundary which is within 0 - 30 mm to the left\* of the centre line.

\* Right on right-hand drive cars.

- b Adjust the headlamp sideways so that the high-intensity zone (A) is as close to the centre as possible. For the optimum setting, use the tolerance band (B) for the light/dark boundary.

Adjust the setting of the other headlamp in the same way.

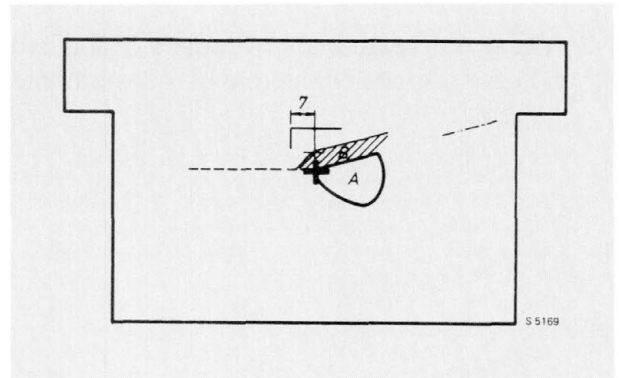

If difficulty is experienced in obtaining the correct setting, check the distribution of the main beam (usually slightly too far to the left\*) and check that the bulb is fitted correctly.

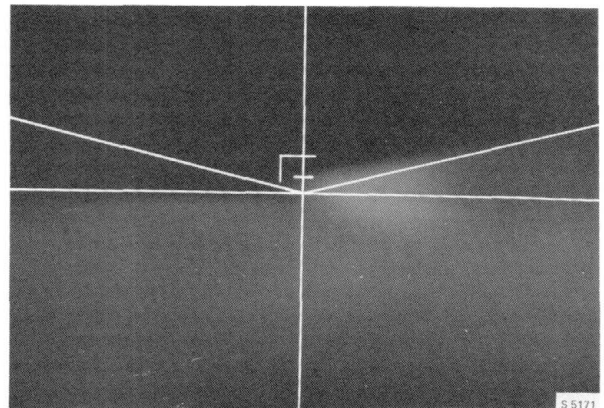

*Correct setting*

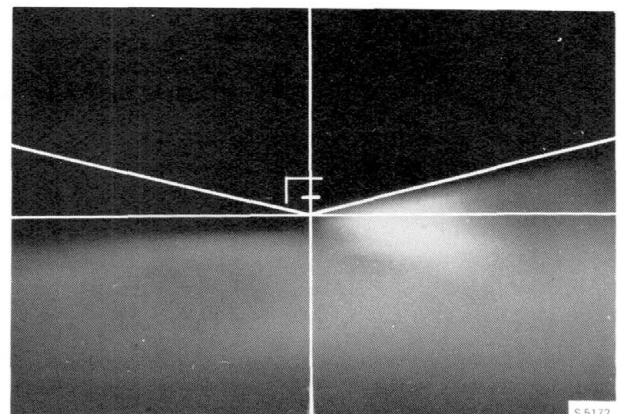

*Incorrect setting*

## Headlamp alignment (US, JP)

Align the headlamps using special aligning equipment.

- 1 Open the bonnet.
- 2 Adjust the headlamps by means of the two adjusting knobs on the rear of the headlamp housing.

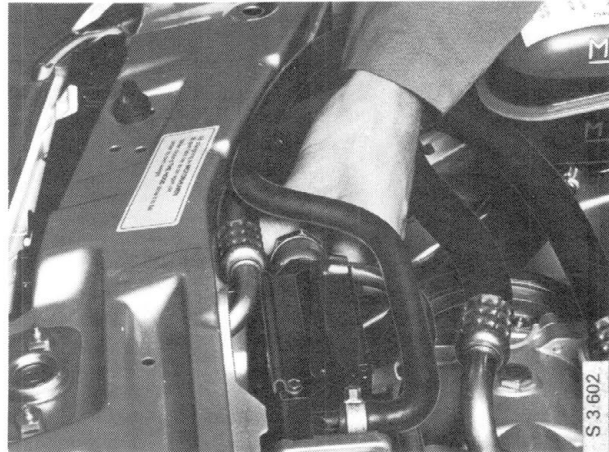

Align as follows:

- Check the tyre pressures, load the car as it would normally be loaded and position the car at right-angles to the headlamp aligning unit.
- Set the lens of the aligning unit in accordance with the manufacturer's specifications.

---

### **N.B.**

Always follow the manufacturer's instructions for the headlamp alignment equipment.

---

# Direction indicators

Principle of operation . . . . .	361-1	To remove the direction indicator stalk switch . . . . .	361-2
Changing the bulbs . . . . .	361-2	To remove the flasher relay . . . . .	361-4

The direction indicators consist of flashing lamps at the front, on the sides and at the rear. The indicator lamps are incorporated into the front and rear lamp clusters and the side direction indicator lamps, and flash with an orange light when switched on.

## Principle of operation

The flashing frequency is controlled by a flasher relay located on the relay board. The direction indicator system incorporates two warning lamps in the combined instrument which flash at the same rate as the direction indicator lamps.

If a warning lamp fails to flash when the indicators are operating, this may indicate that one of the indicator lamps is not working. If the flasher relay is working normally and bulbs of the correct rating are fitted, the flashing frequency should be 60 - 120 flashes a minute.

### N.B.

If bulbs of the wrong rating are fitted, the flasher relay will not operate at the correct frequency.

The direction indicators are controlled by a stalk switch on the left-hand side of the steering column, below the steering wheel. The switch also serves as a dip switch.

The direction indicators can also be operated as hazard warning lights by means of the switch located above the direction indicator stalk switch. When the hazard warning lights are switched on, all direction indicator lamps will flash simultaneously.

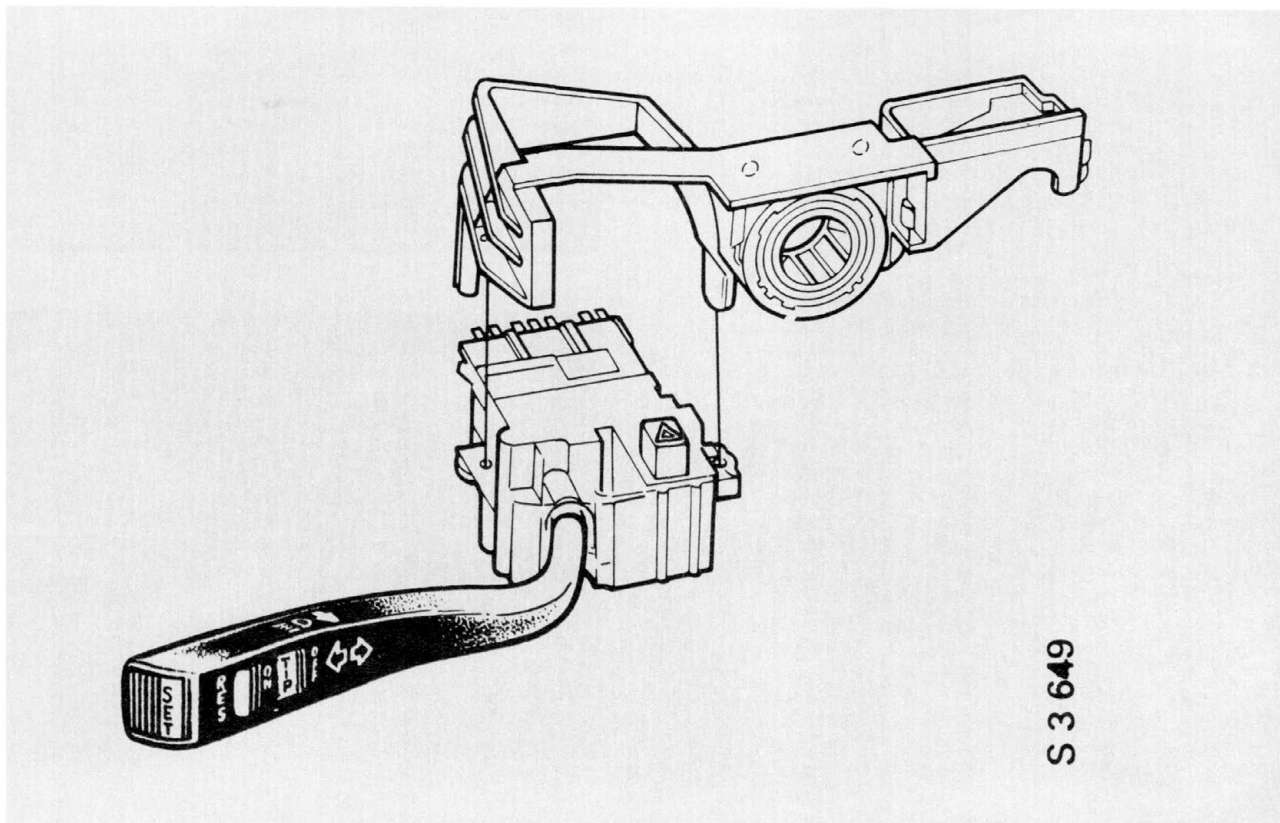

### Changing the bulbs

#### Direction indicator lamps

See Section 351 "Lighting".

#### Warning lamps in the combined instrument

See Section 381 "Instruments".

### Direction-indicator stalk switch

#### To remove

- 1 Disconnect the negative (-) battery cable.

---

#### N.B.

**Never** disconnect the battery when the engine is running, since serious damage to the alternator may result.

---

- 2 Pull out the steering wheel as far as it will go.



- 3 Remove the covers from the steering column bearing bracket (four screws).

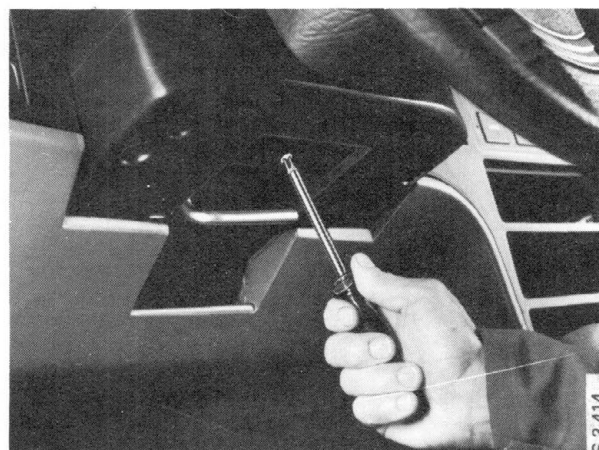

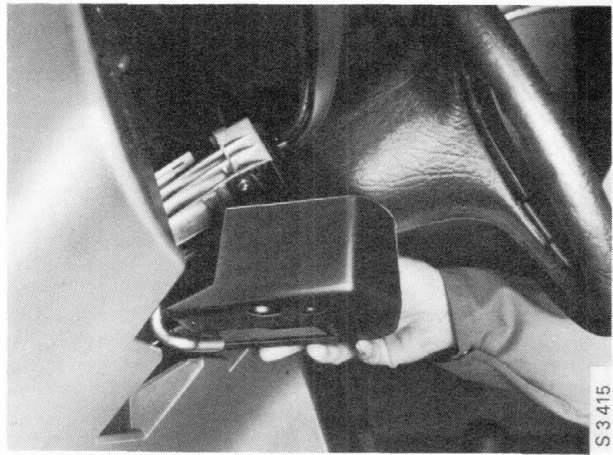

4 Disconnect the top connector.

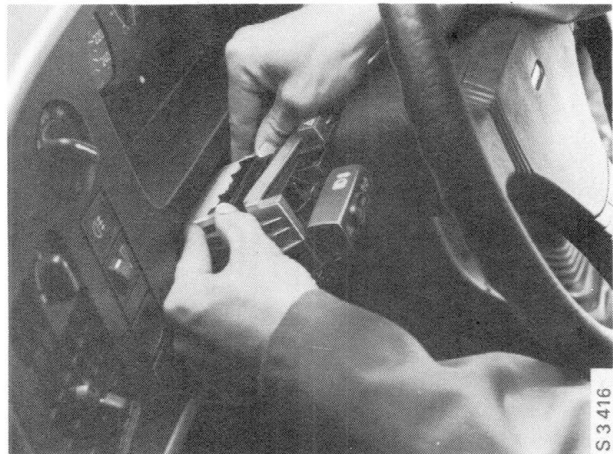

5 Remove the two stalk-switch retaining screws.

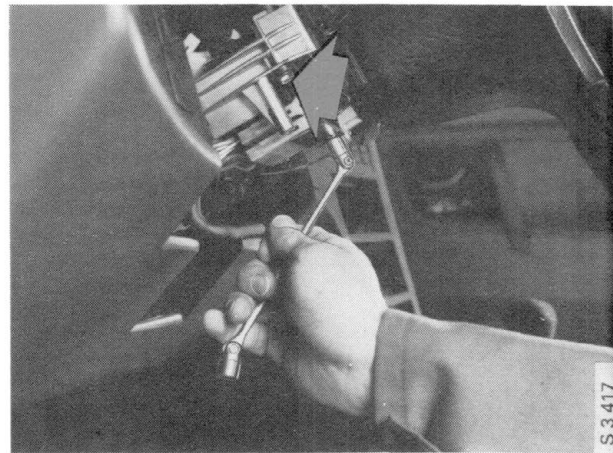

6 Remove the switch and disconnect the lower connector.

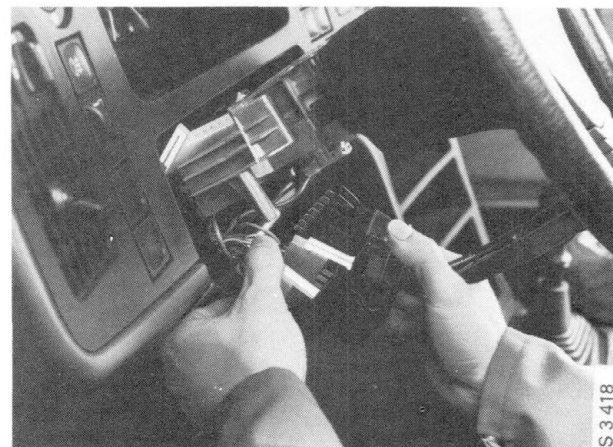



### **To fit**

Refit in the reverse order.

### **Flasher relay**

#### **To remove**

See Section 371 "Cables, fuses and relays"

# Horn, horn controls

Horn . . . . . 362-2

Horn switch . . . . . 362-3

The Saab 9000 is fitted with two windtone horns tuned to give two notes - one high and one low.

One of the horns is located between the radiator and the radiator grille and the other inside the left-hand wheel housing.

The horn is operated by means of switches incorporated into the steering wheel.

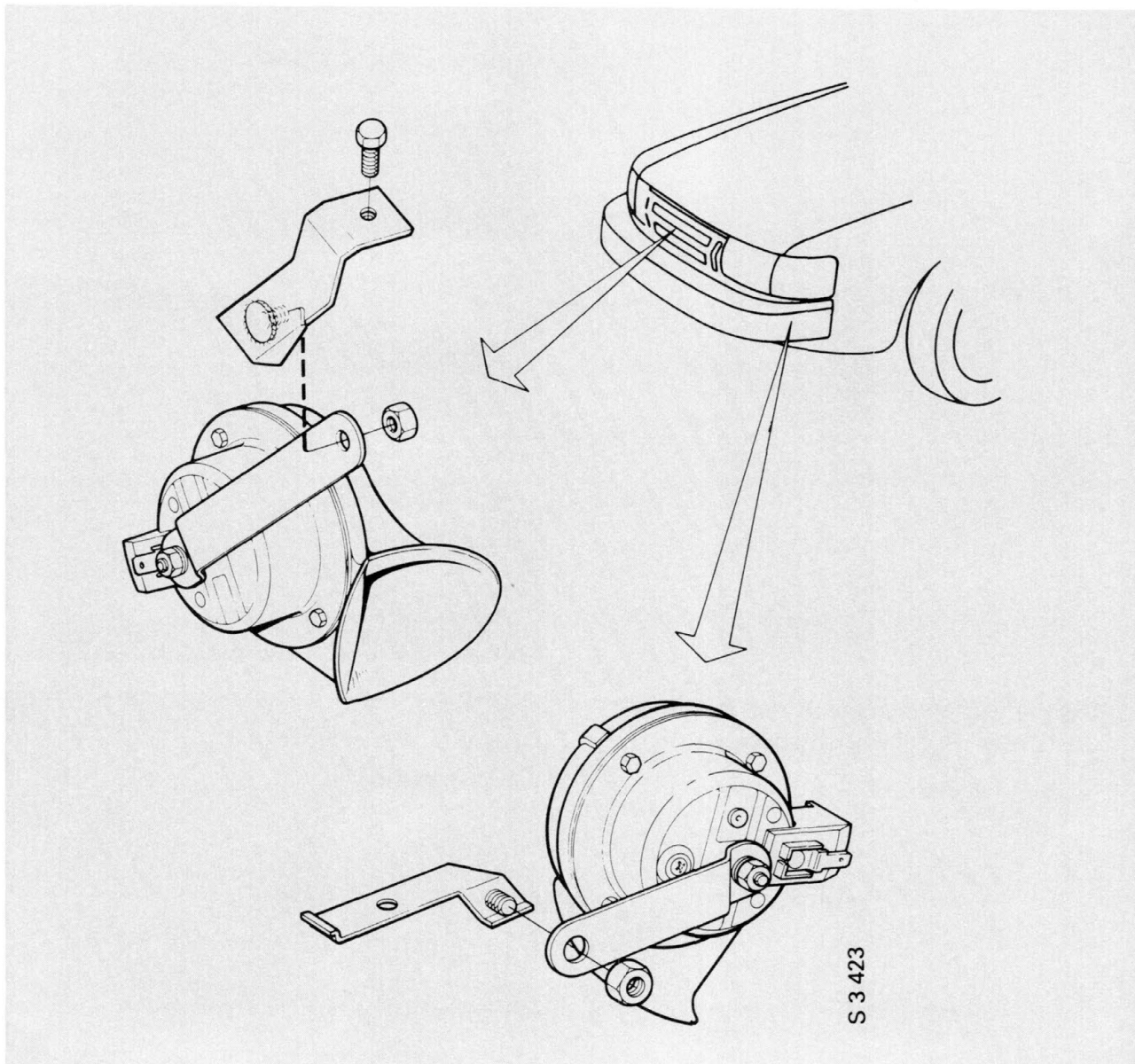

## Horn

### To remove

- 1 Disconnect the negative (-) battery cable.

---

#### N.B.

**Never** disconnect the battery when the engine is running, since serious damage to the alternator may result.

---

- 2 Remove the radiator grille.



- 3 Disconnect the horn connector.

- 4 Remove the horn.

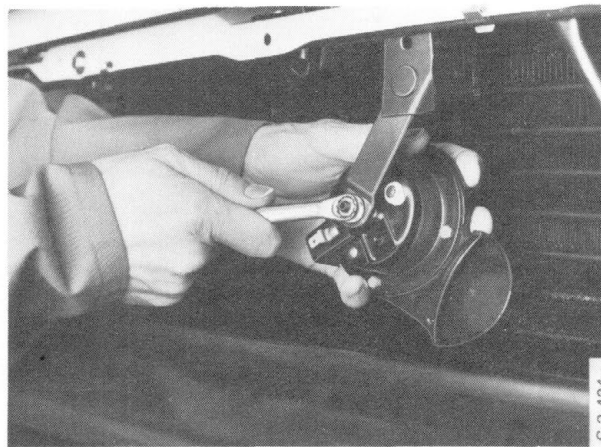

- 5 Disconnect the connector from the horn in the left-hand front wheel housing.

- 6 Remove the horn.

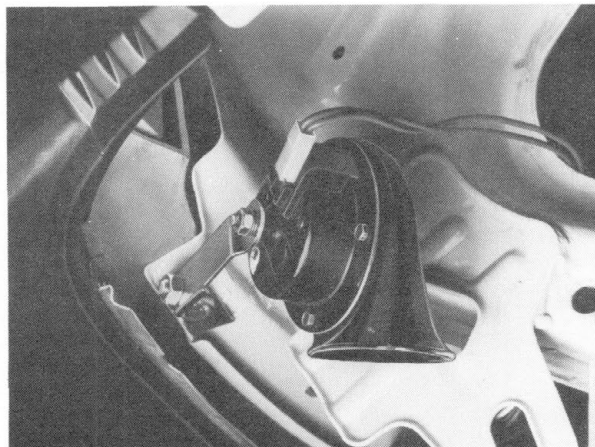

### To fit

Refit in the reverse order

## Horn switch

### To remove (Turbo)

- 1 Remove the three horn buttons.

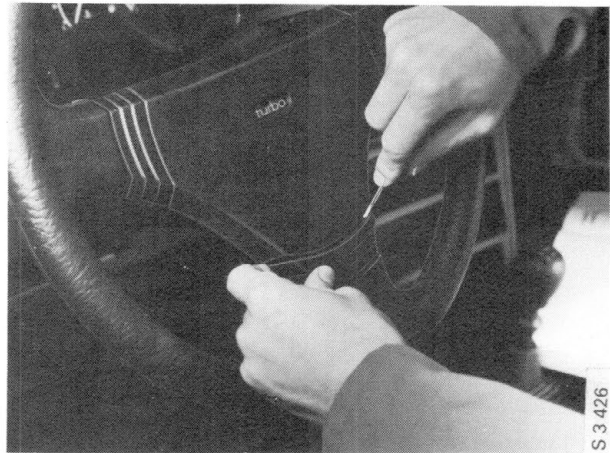

- 2 Lift out the spring contacts.

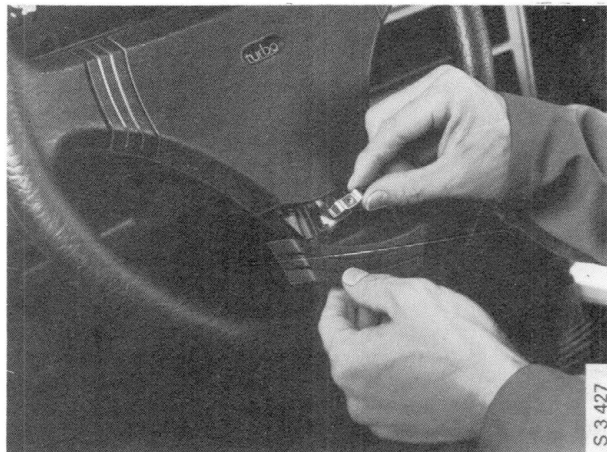

### To remove (Injection)

- 1 Remove the two horn buttons and disconnect the wiring.

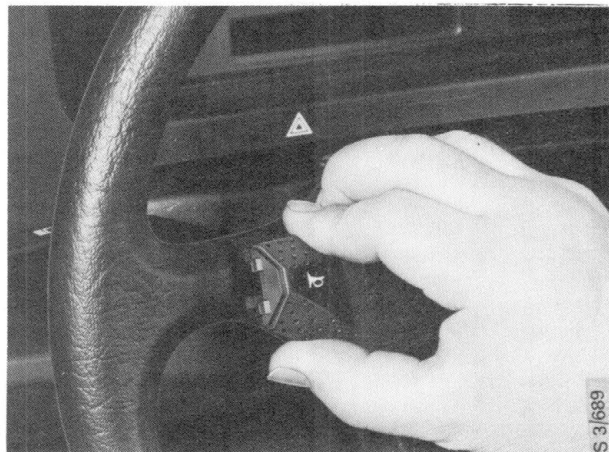

### To fit

Refit in the reverse order

# Wipers and washers

Windscreen wiper mechanism . . . . .	363-2	Washer fluid reservoir . . . . .	363-12
Headlamp wiper assembly . . . . .	363-6	Washer pump . . . . .	363-13
To change the wiper/washer stalk switch . . . . .	363-9	Fluid level switch . . . . .	363-14

The wiper and washer equipment comprises one unit for the windscreen and a separate system for each headlamp.

The wiper motors incorporate an automatic parking function which always returns the wipers to the same position when they are switched off.

The wiper system for the windscreen includes a two-speed motor and a relay for intermittent operation of the wipers.

The headlamp wiper system consists of a separate motor for each wiper, fitted underneath each headlamp. The motors have built-in overload protection (e.g. to avoid damage to the motor if the wiper blade should freeze to the lens) consisting of a switch actuated by a PTC resistor connected in series with the motor. A diode in the supply circuit prevents reverse current being supplied from the motor to the washer pump.

The washer system consists of a fluid reservoir with a built-on pump and fluid level switch, and hoses and nozzles for the headlamps and windscreen.

The washer reservoir capacity is about 4.2 l (4.4 qts) and the reservoir is mounted under the bonnet, on the left-hand wheel housing. The washer pump and fluid level switch are located in the bottom of the reservoir. The fluid level switch lights up a warning lamp in the combined instrument when the volume of washer fluid has fallen to less than about 0.5 l (0.5 qts).

The nozzles for the windscreen washers are fitted in the bonnet. The nozzle on the driver's side has two jets and the one on the co-driver's side has one jet. A non-return valve in the hose to the windscreen washer nozzles prevents the hose from draining when the washers are switched off. The nozzles for the headlamp washers are incorporated into the wiper arms. A delivery valve in the supply hose to these nozzles opens when the pressure has risen to between 0.35 and 0.50 bar (5.1 - 7.2 psi). The purpose of this is to guarantee a certain supply of fluid to the windscreen washers before the headlamp washers start to operate.

The wiper/washer systems are operated by means of a stalk switch on the right-hand side of the steering column, below the steering wheel.

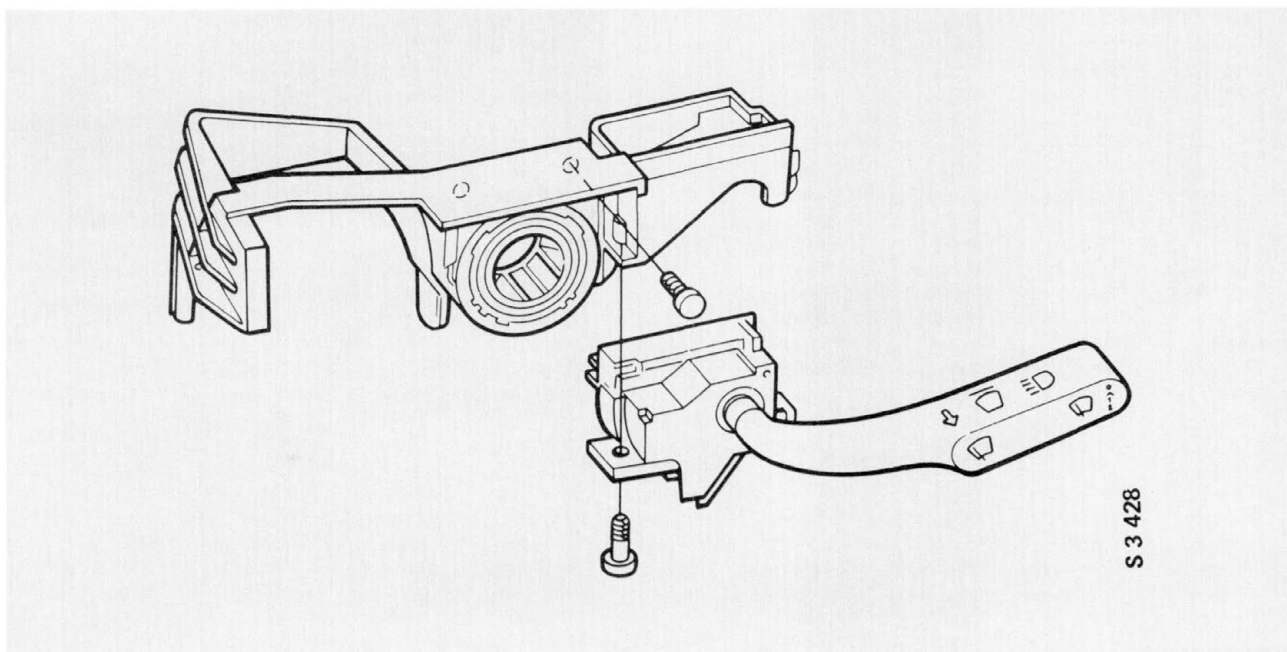

## Windscreen wiper mechanism

### To remove

- 1 Disconnect the negative (-) battery cable.

---

#### **N.B.**

**Never** disconnect the battery when the engine is running, since serious damage to the alternator may result.

---

- 2 Raise the covers on the wiper arms, remove the nuts and remove the arms.

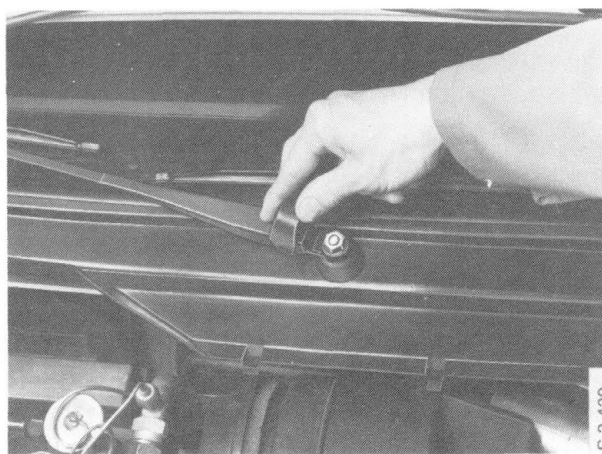

3 Remove the rubber covers from the spindles.

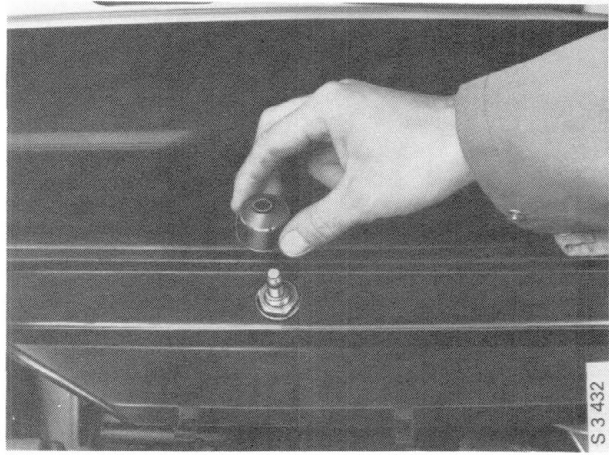

4 Remove the two bulkhead partition bolts.

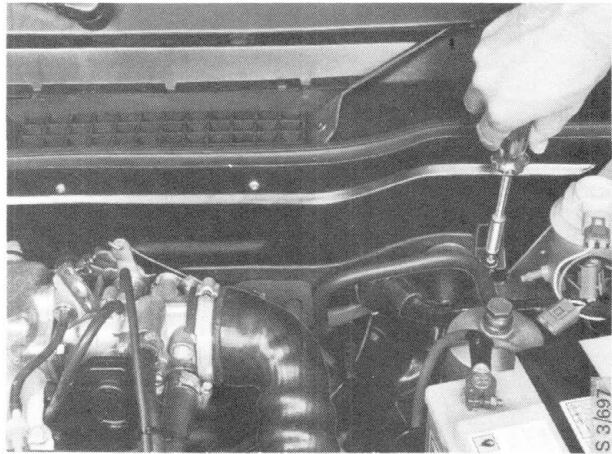

5 Lift out the bulkhead partition.

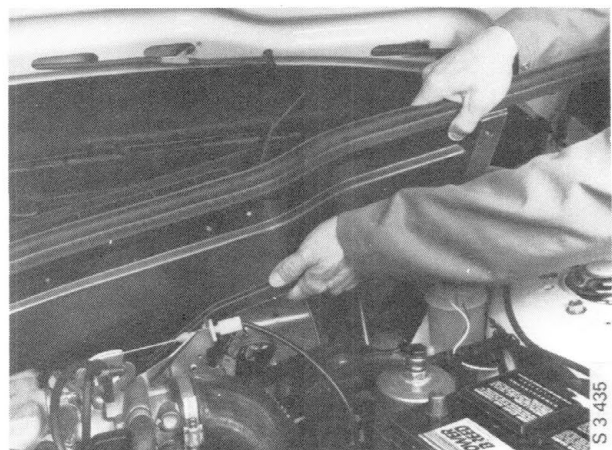

## 363-4 Wipers and washers

- 6 Disconnect the connectors from the wiper motor.

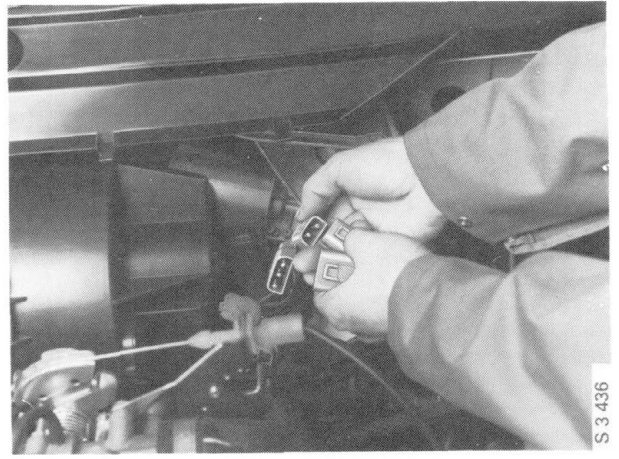

- 7 Remove the spindle nuts.

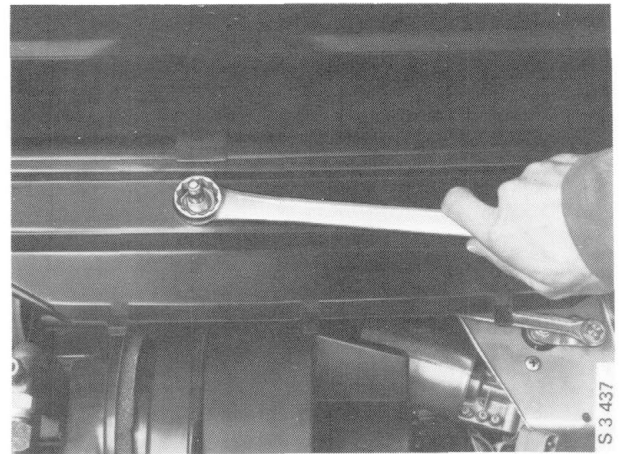

- 8 Remove the four securing bolts for the wiper-motor bracket.

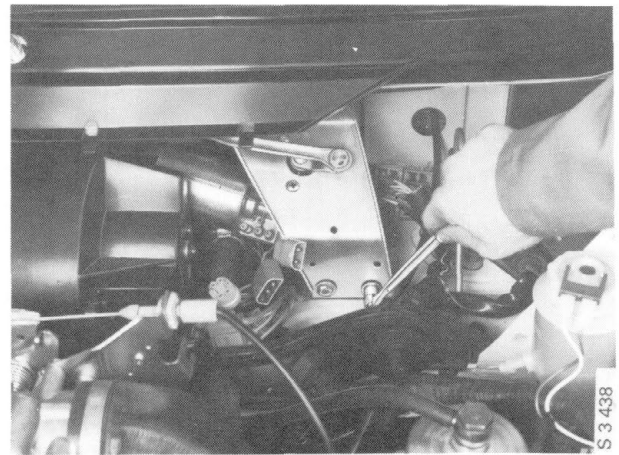



- 9 Push down and pull forward the push-rod for the left-hand wiper.

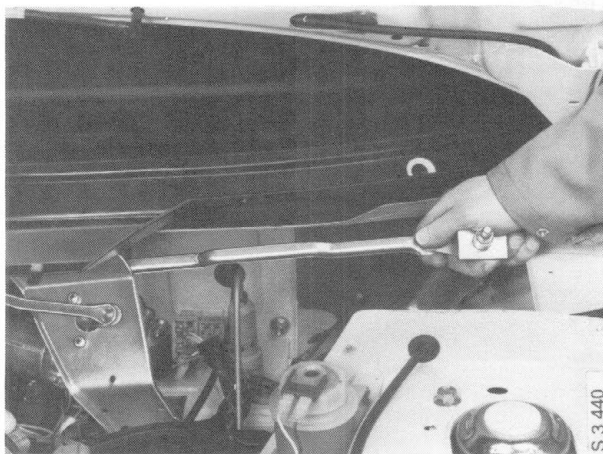

- 10 Lift out the wiper motor, complete with bracket and push-rod linkage.

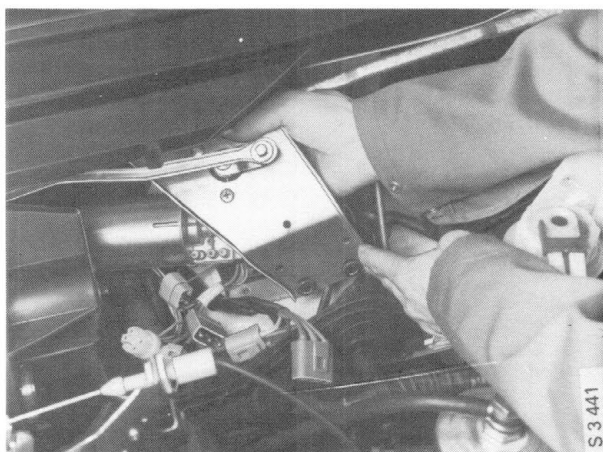

To ease removal, hold down the cables under the wiper motor bracket while withdrawing the motor.

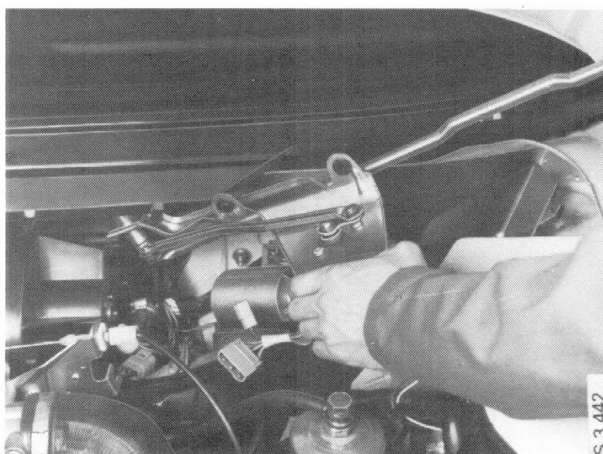

### To fit

Refit in the reverse order.

## Headlamp wiper assembly (not US, JP)

### To remove, left-hand side

- 1 Disconnect the negative (-) battery cable.

---

#### **N.B.**

**Never** disconnect the battery when the engine is running, since serious damage to the alternator may result.

---

- 2 Remove the air intake pipe.

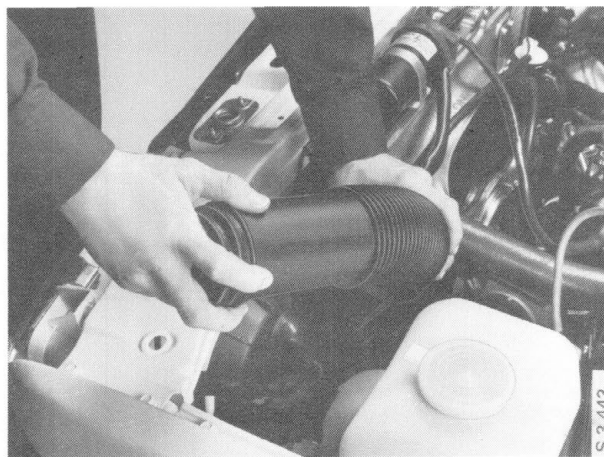

- 3 Disconnect the washer hose at the wiper arm.



- 4 Raise the cap over the wiper-arm spindle and remove the nut. Pull off the wiper arm.

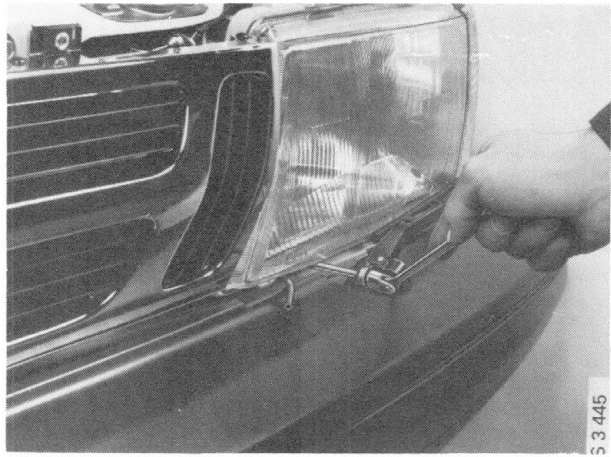

- 5 Disconnect the wiper motor connector.



- 6 Remove the nut from the wiper motor clamp and remove the clamp.

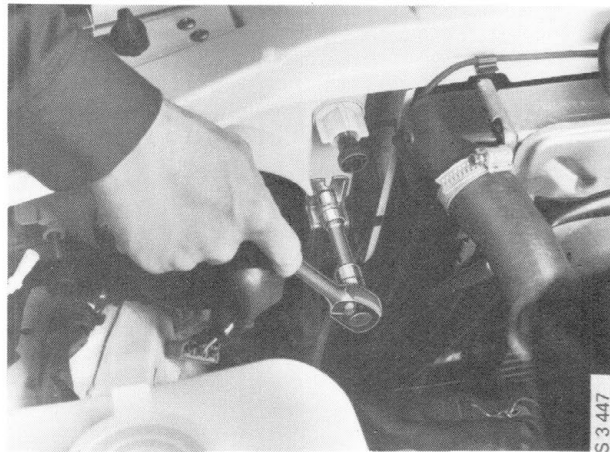

- 7 Remove the wiper motor by withdrawing it towards the rear.



**To fit**

Refit in the reverse order.

### To remove, right-hand side

- 1 Disconnect the negative (-) battery cable.

---

#### **N.B.**

**Never** disconnect the battery when the engine is running, since serious damage to the alternator may result.

---

- 2 Remove the headlamp (see Section 351 "To remove the headlamps").



- 3 Raise the cap over the wiper arm spindle and remove the nut. Pull off the wiper arm.



- 4 Remove the nut from the wiper motor clamp and remove the clamp.

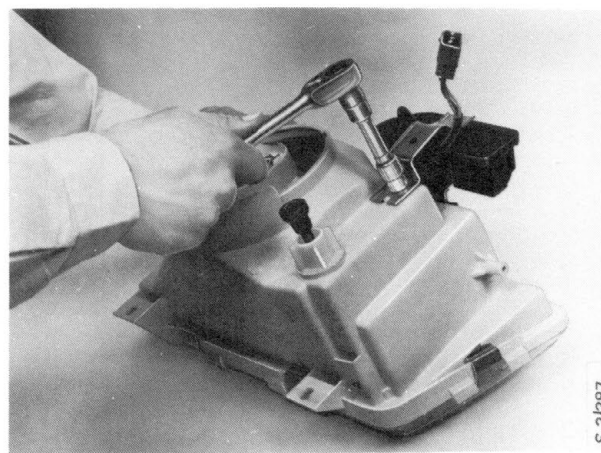

- 5 Remove the wiper motor by withdrawing it towards the rear.

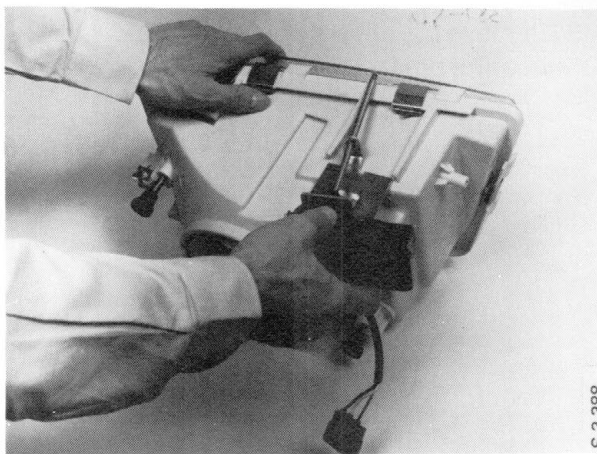

### To fit

Refit in the reverse order.

After refitting the headlamp, check the alignment.

### To remove the wiper/washer stalk switch

- 1 Disconnect the negative (-) battery cable.

---

#### **N.B.**

**Never** disconnect the battery when the engine is running, since serious damage to the alternator may result.

---

- 2 Pull out the steering wheel as far as it will go.



## 363-10 Wipers and washers

- 3 Remove the covers from the steering column bearing bracket (four screws).

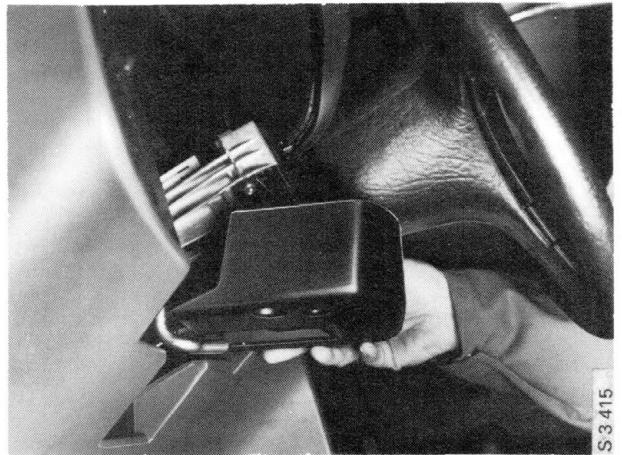
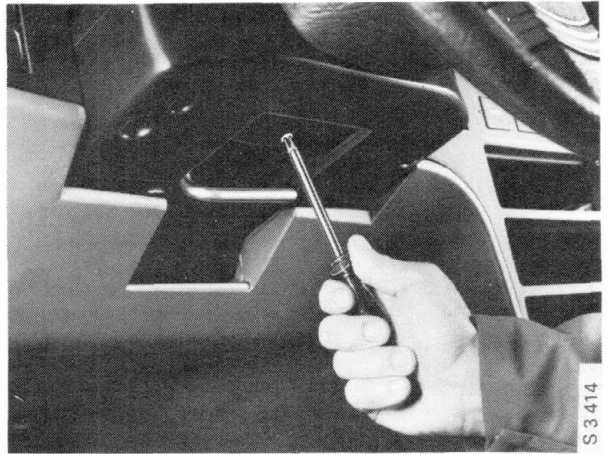

- 4 Disconnect the connector.



- 5 Remove the switch securing screws.



6 Remove the wiper/washer stalk switch.



**To fit**

Refit in the reverse order.

**Washer fluid reservoir**

**To remove**

- 1 Disconnect the negative (-) battery cable.

**N.B.**

**Never** disconnect the battery when the engine is running, since serious damage to the alternator may result.

- 2 Disconnect the hose from the washer pump.

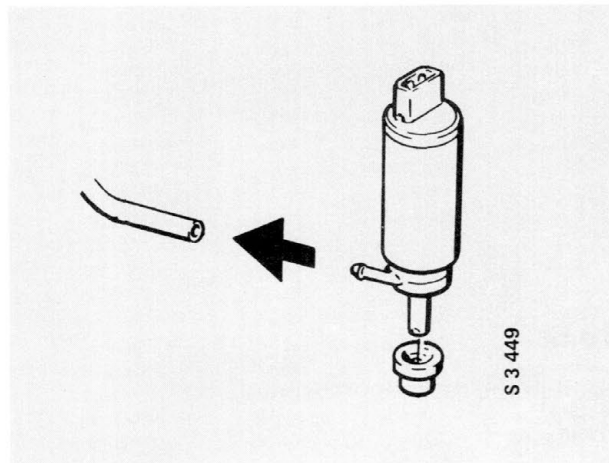

- 3 Disconnect the connectors from the washer pump and fluid level switch.

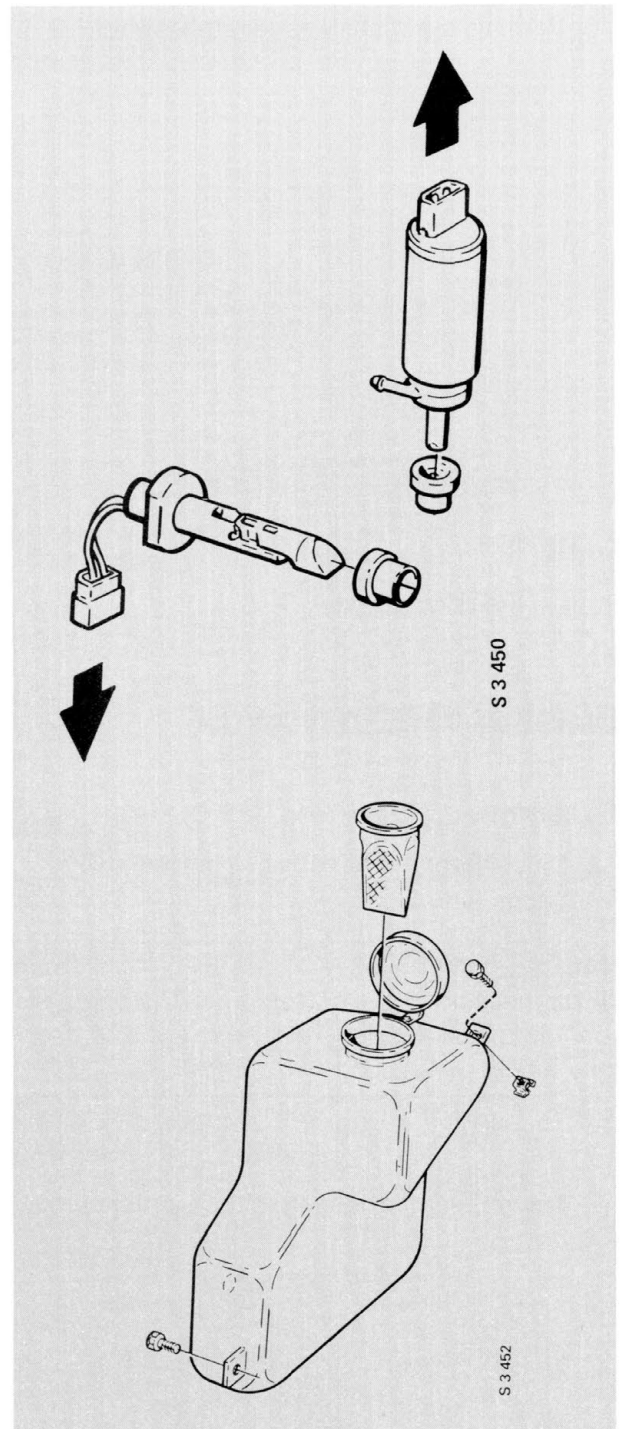

- 4 Remove the two reservoir securing bolts. Lift out the reservoir.

### To fit

Refit in the reverse order.



## Washer pump

### To remove

- 1 Disconnect the negative (-) battery cable.

#### N.B.

**Never** disconnect the battery when the engine is running, since serious damage to the alternator may result.

- 2 Disconnect the hose from the washer pump.

#### N.B.

To avoid spillage when the washer pump is removed, make sure that the washer fluid reservoir contains no more than 0.5 l (0.5 qts) of fluid.

- 3 Disconnect the electrical connector from the pump.

- 4 Remove the pump by easing it out slightly and then withdrawing it straight up through the rubber bush.

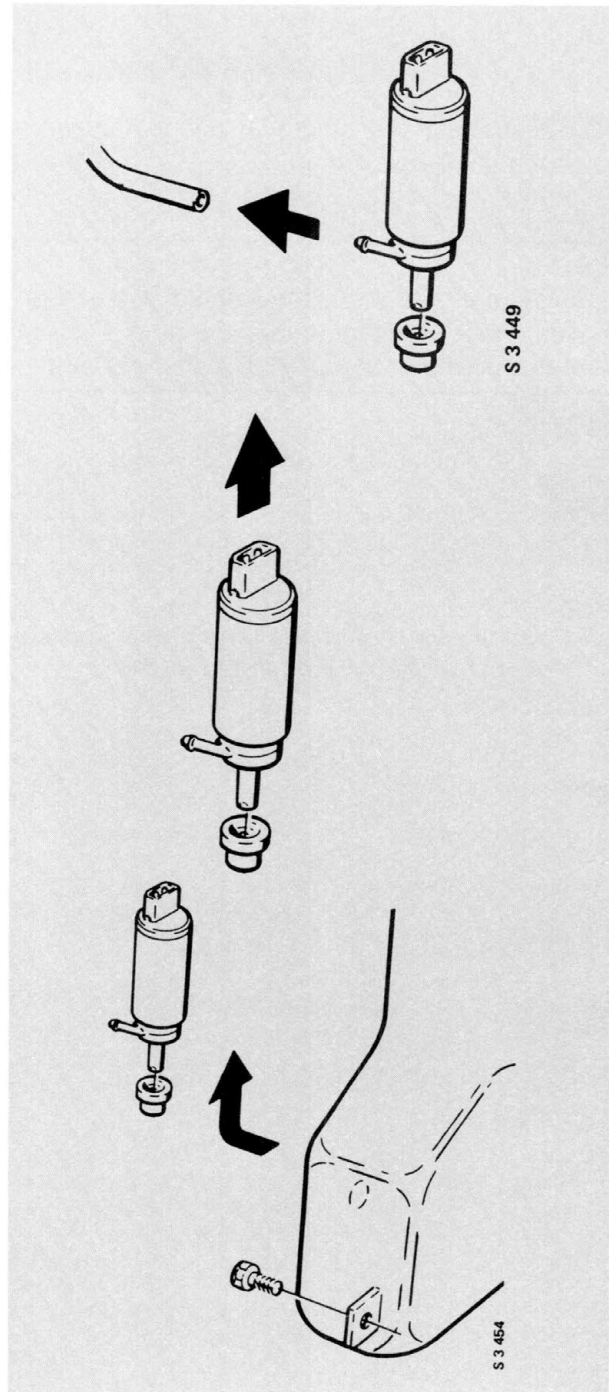

### To fit

Refit in the reverse order

## Fluid level switch

### To remove

- 1 Disconnect the negative (-) battery cable.

---

#### N.B.

**Never** disconnect the battery when the engine is running, since serious damage to the alternator may result.

---

- 2 Disconnect the electrical connectors from the fluid level switch.

---

#### N.B.

To avoid spillage when the washer pump is removed, make sure that the washer fluid reservoir contains no more than 0.5 l (0.5 qts) of fluid.

---

- 3 Remove the fluid-level switch by withdrawing it straight up through the rubber bush.

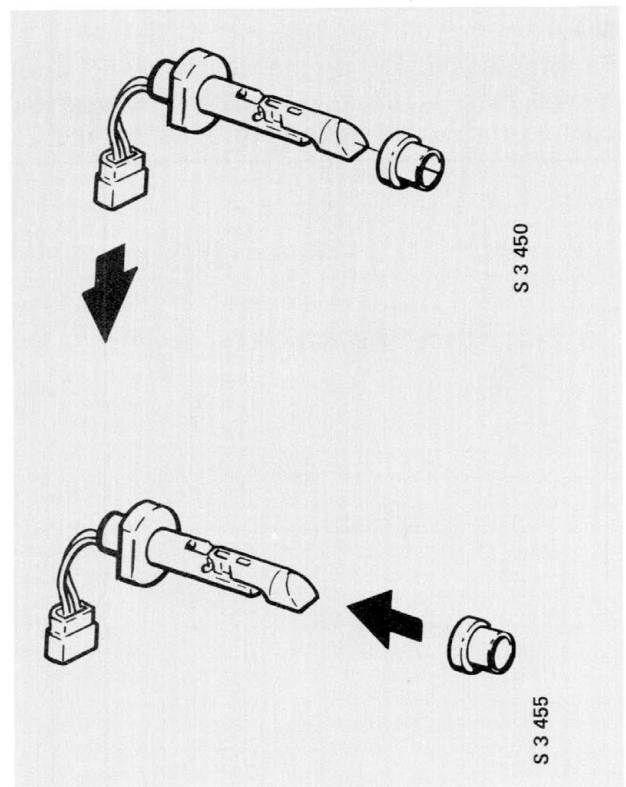

### To fit

Refit in the reverse order.

# Electrical controls and switches

Steering-column switches and controls . . . . .	364-1	Switches . . . . .	364-7
Horn switch . . . . .	364-3	Switches for interior lighting . . . . .	364-12
Brake warning lamp switch . . . . .	364-3	Door indication switches . . . . .	364-13
Brake light switch . . . . .	364-3	Switches for rear-window heater and ventilation fan . . . . .	364-14
Switch for handbrake warning lamp . . . . .	364-4	Switch for luggage compartment illumination . . . . .	364-16
Switches for starting interlock and shift-up indication . . . . .	364-4	Thermostatic switch for radiator fan . . . . .	364-17
Seat belt warning lamp . . . . .	364-4	Outside temperature transmitter . . . . .	364-17
Switches for electric windows/sunroof . . . . .	364-5	Transmitter for electronic speedometer . . . . .	364-17
Rear-view mirror switches . . . . .	364-6	Reversing light/shift-up indication switch . . . . .	364-18
Rheostat for instrument lighting . . . . .	364-7		

## Steering-column switches and controls

The dip switch, the controls for the direction indicators, wipers, washers and Cruise Control, and the ignition switch are located on the steering column. The connection for the horn switch is also located at the top of the steering column.

### To change the direction-indicator switch

See Section 361 "Direction indicators".

### To change the wiper/washer stalk switch

See Section 363 "Wipers and washers"

### To change the ignition switch.

- 1 Disconnect the negative (-) battery cable.

#### N.B.

**Never** disconnect the battery when the engine is running, since serious damage to the alternator may result.

- 2 Pull out the steering wheel as far as it will go.

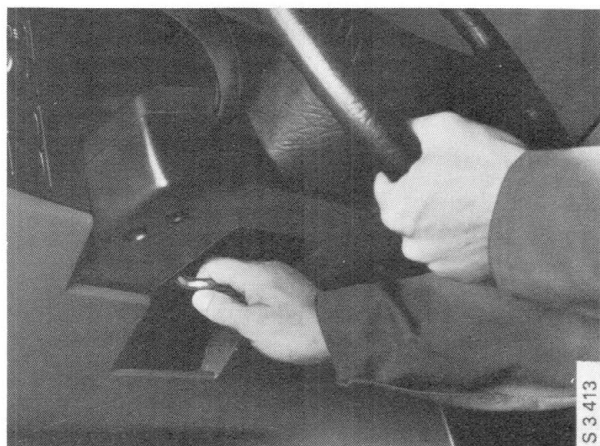

## 364-2 Electrical controls and switches

- 3 Remove the covers from the steering column bearing bracket (four screws).



- 4 Remove the two Allen screws from the underside of the switch unit.

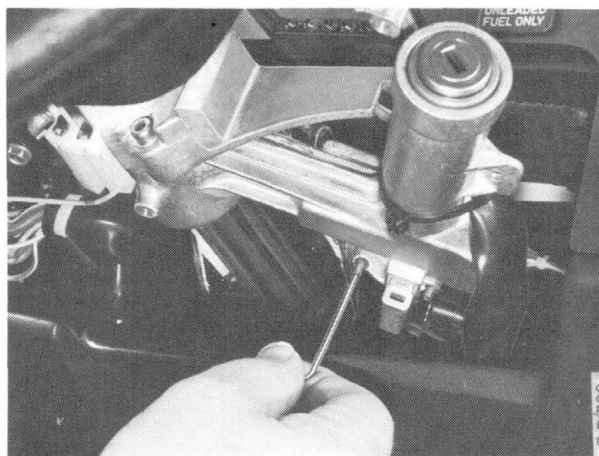

- 5 Pull the switch forward and disconnect the connector from the ignition switch.

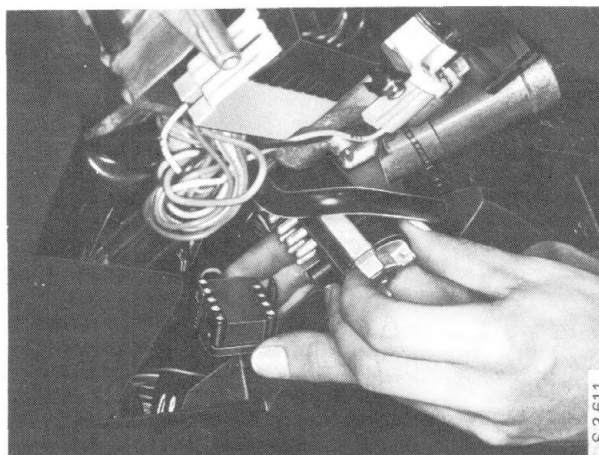

## Horn switch

The connector for the horn switch is located below the steering wheel.

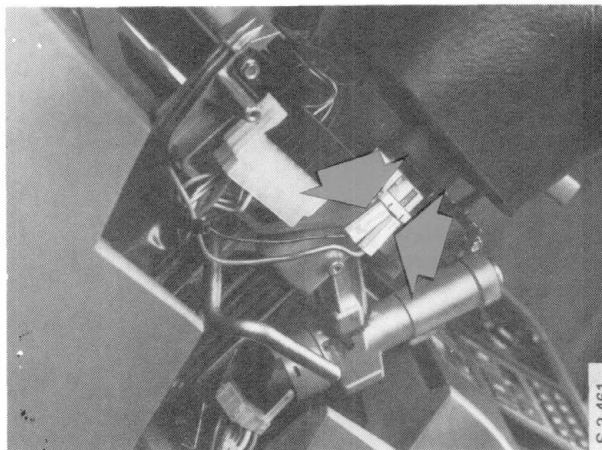

## Brake warning lamp switch

The switch for the brake warning lamp is fitted in the filler cap on the brake fluid reservoir. The switch is actuated by a float which senses the fluid level in the reservoir. When the fluid has dropped below a predetermined level, the switch will close and the warning lamp on the instrument panel will light up.

To check the switch, depress the contact in the centre of the filler cap.

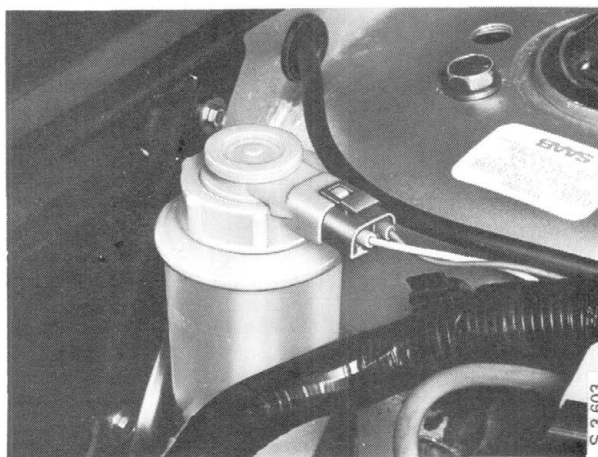

## Brake light switch

The brake light switch is actuated mechanically by the brake pedal. The switch is located in the pedal assembly adjacent to the push-rod to the brake servo unit. The switch should be adjusted so that the brake lights are switched on when the pedal has been depressed about 10 mm.



## Switch for handbrake warning lamp

The switch for the handbrake warning lamp is fitted to a bracket below the handbrake lever. The switch is accessible after the centre console has been removed.

(For removal instructions, see Group 8, Section 853 "Centre console".)



## Switches for starting interlock and selector position (only cars with automatic transmission)

The switches are mounted in the selector lever housing and are accessible for replacement after the rear section of the centre console and the air duct have been removed.

For removal instructions, see Section 351 "Lighting for the selector lever scale" and Group 8, Section 853 "Centre console".

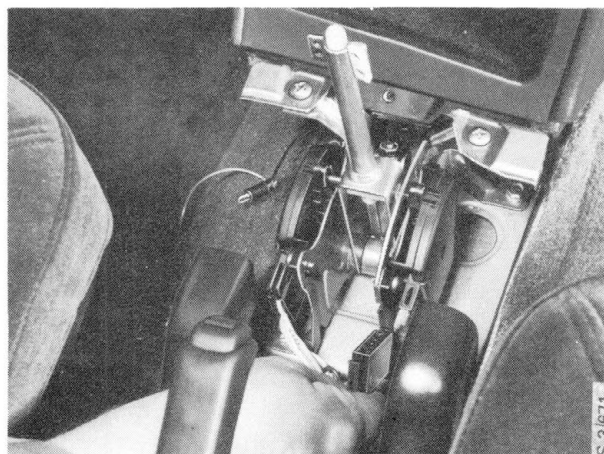

## Seat belt warning lamp

A warning lamp on the roof console will be switched on if a front-seat occupant has not fastened his seat belt (on certain markets, a buzzer will also sound).

The seat-belt warning system includes the following components:

- Warning lamp on roof console
- Switch in co-driver's seat
- Contacts in the seat-belt buckle
- Relay for the seat belt/ignition key warning buzzer in the electrical distribution box behind the glove compartment.

The seat belt warning lamp will be switched on if the ignition is switched on and:

- a The driver has not fastened his seat belt, or
- b The co-driver has not fastened his seat belt.



## Switches for electric windows/ sunroof

The switches for the electrically operated windows and sunroof are located on the centre console between the front seats. All windows and the sunroof can be operated from this array of switches. An interlock switch on the centre console enables the driver to render inoperative the window control switches on the rear doors.

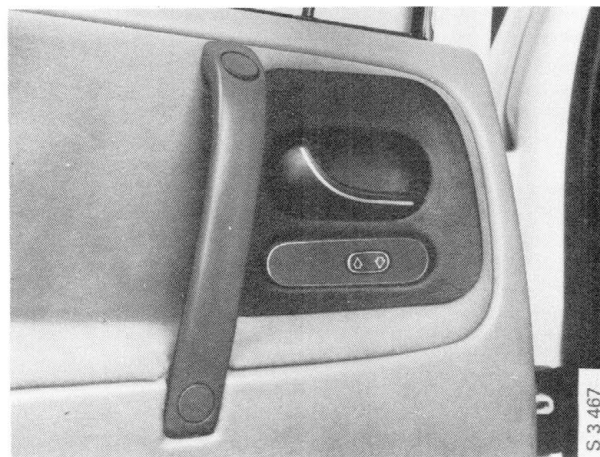
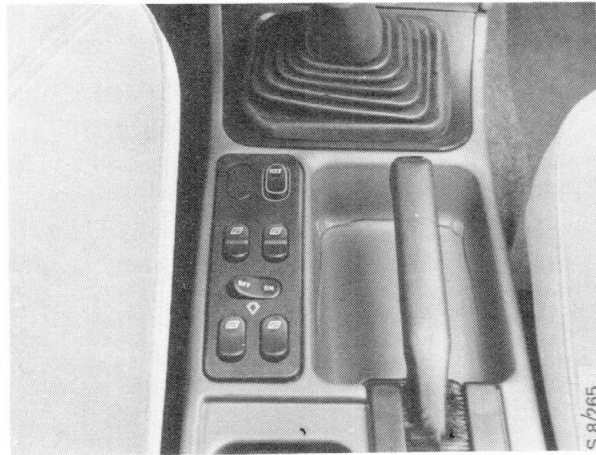

### Electrically operated windows

The windows are operated by spring-loaded two-position switches (three-position switch for the driver's door) located in the centre console between the front seats.

The electric motors include limit switches which will automatically stop the motor when the window has reached the top or bottom limit of its travel. The motor also includes a slipping clutch which will come into operation if the window does not move freely.

### Automatic window regulator control

All cars with electric window regulators are equipped with a three-way switch and a relay for operating the window in the driver's door.

The switch has two contact positions for the downward travel of the window and one contact position for the upward travel.

The window can be opened as follows:

- If the switch is depressed lightly to the first contact position, the window will keep opening as long as the button is kept depressed.
- If the button is depressed more firmly to the second contact position, the relay will be energised and the downward travel of the window will continue even after the switch has been released. The downward travel will be interrupted when the window has reached the bottom limit of its travel or if the switch is actuated for closing the window.

### To remove

- 1 Gently prise up the switch panel using a screwdriver.



- 2 Lift off the panel.

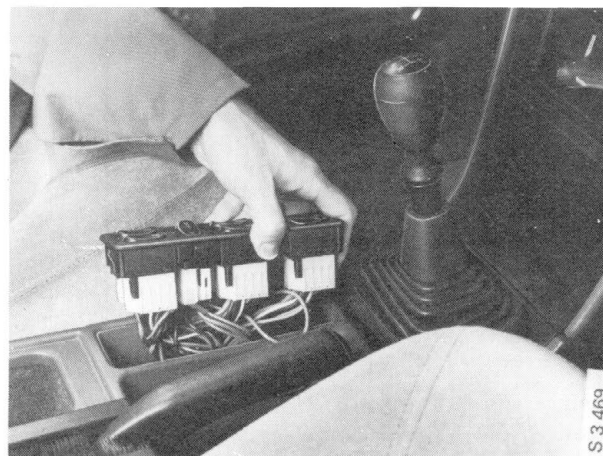

### Rear-view mirror switches

The switches for adjusting the outer rear-view mirrors are located on the driver's door. The rear switch is used to select the appropriate mirror, and the front switch is then used to adjust the selected mirror.





## Dimmer rheostat for instrument lighting

The dimmer rheostat for the instrument lighting is located on the fascia, to the left of the steering wheel.

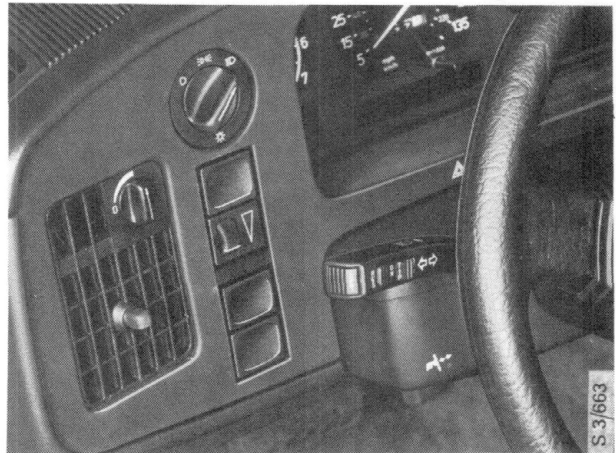

## Electronic unit for the instrument lighting

The electronic unit for the instrument lighting is located on the right-hand side, under the fascia.

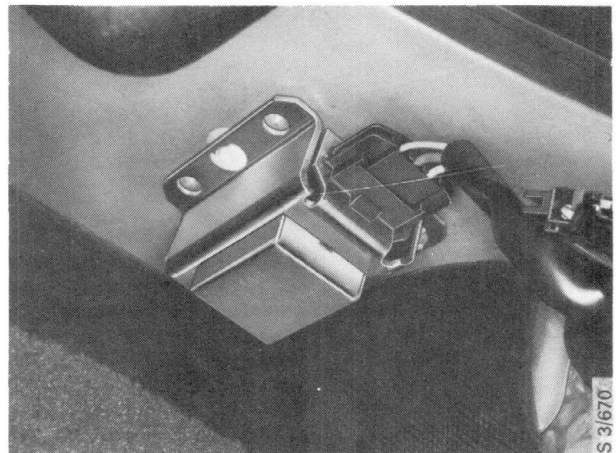

## Switches

### To remove the light switch

- 1 Withdraw the switch.



2 Disconnect the connector.



3 Change the bulb.

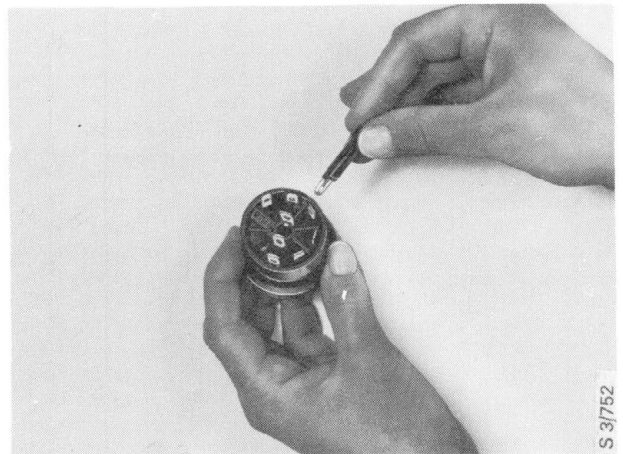

## To remove the rheostat switch

1 Remove the blank covers below the rheostat switch.

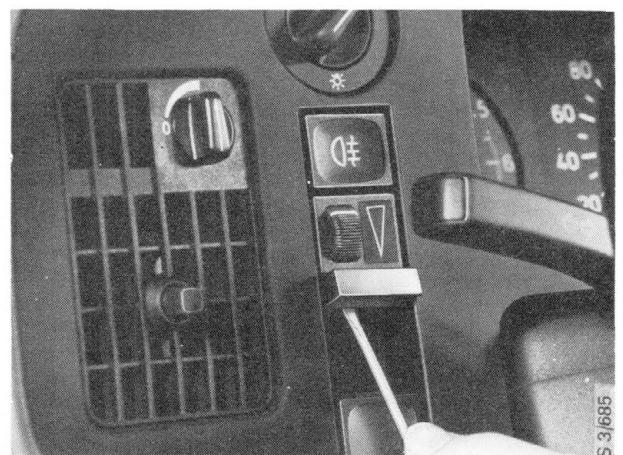

- 2 Remove the switch for the rear fog lights or fog lights.

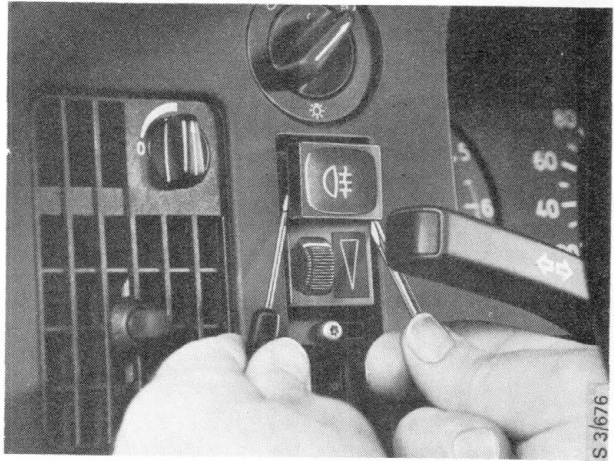

- 3 Withdraw the rheostat switch.
- 4 Disconnect the connector.

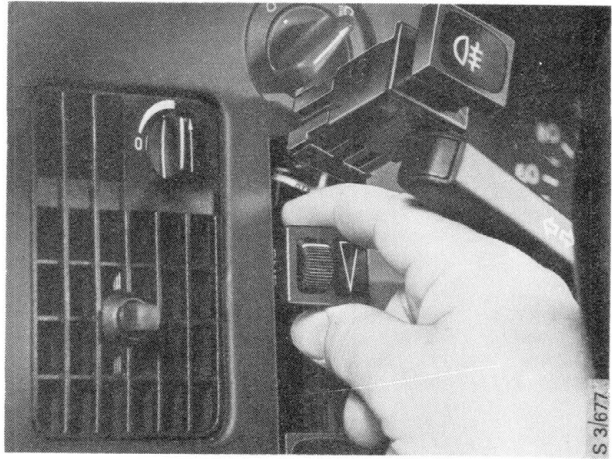

**To remove the switches for the rear fog lights/fog lights, AC, recirculation**

- 1 Withdraw the switch.
- 2 Disconnect the connector.

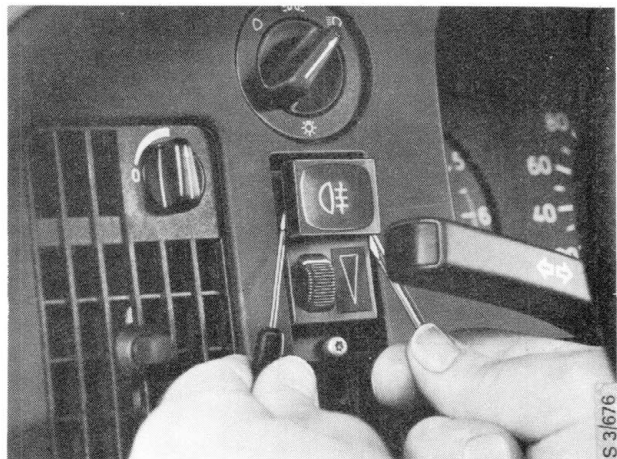

### To remove the switches for variable heating of the front seats.

- 1 Remove the ashtray.



- 2 Bend down the two upper locking tabs and withdraw the ashtray holder forward.

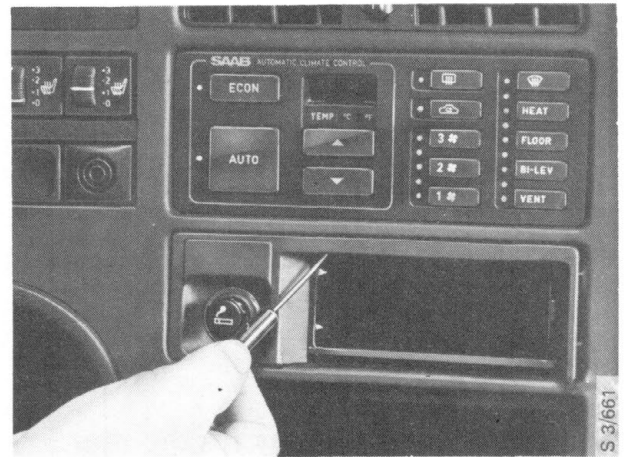

3 Press out the switch.

On cars with ACC, press the ACC panel out to facilitate this work.



4 Disconnect the connector.



### To remove the switch for hazard warning lights

1 Remove the switch button.

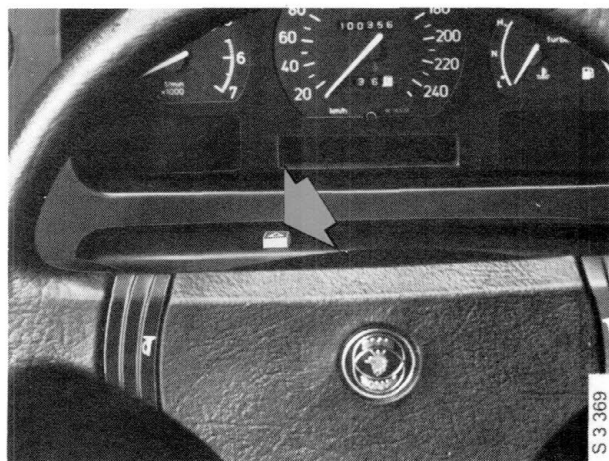

2 Withdraw the bulb and change it.

## Switches for interior lighting

The main switch for the interior lighting and the switch for the front spotlight are located on the roof console.

The switches for the rear reading lights are incorporated into the corresponding lamps.

The interior lights are also operated by switches in the doors.

### To remove the switch from the roof console

- 1 Remove the screw and remove the cover.

On cars with sunroof, the screw is located behind a plastic cover.

- 2 Withdraw the switch.

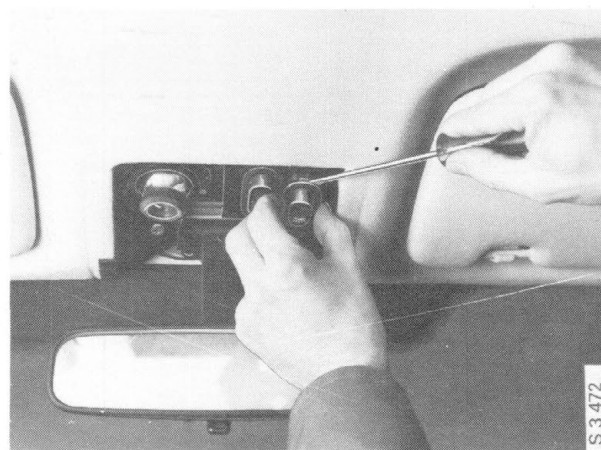
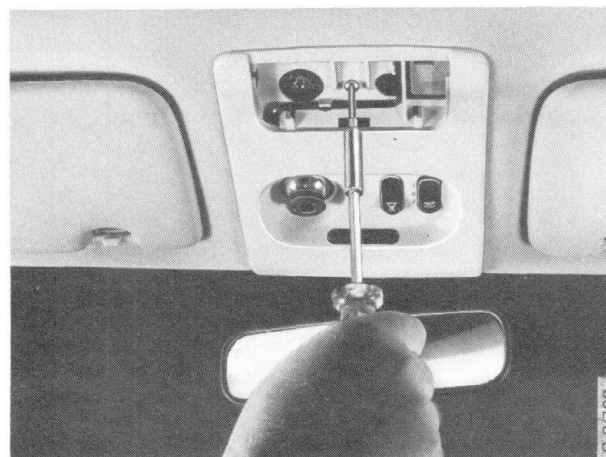
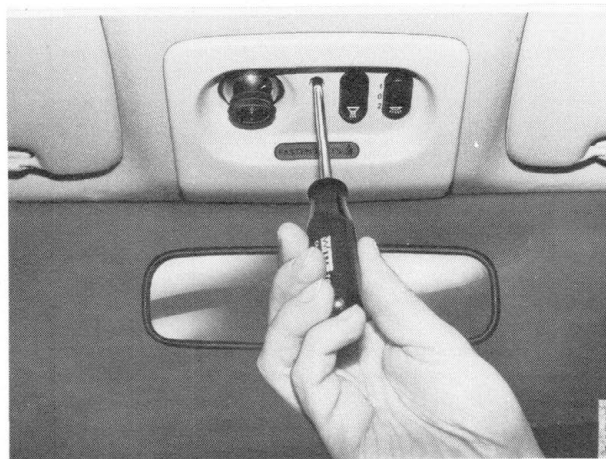

### Door switches for interior lighting

The interior lighting can be switched off by depressing the door switch about 5 mm and turning it through a quarter of a turn to the right. The switch is then locked in this position.



### Door indication switches

The pictogram in the combined instrument includes warning lamps for improperly closed doors. This information is supplied by sensors fitted in the locking mechanism of each of the doors.

The sensors have no moving parts and respond to the position of a magnet in relation to the sensor housing.

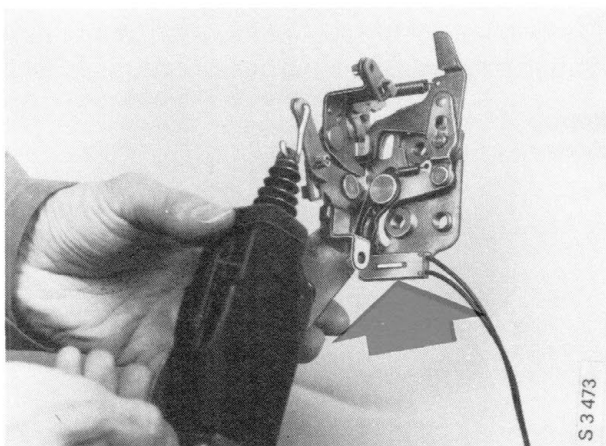

### To remove the door sensor

- 1 Remove the door trim (see Group 8, Section 851 "To remove the door trim panel").
- 2 Remove the plastic foil.
- 3 Remove the sensor.



- 4 Disconnect the connector.

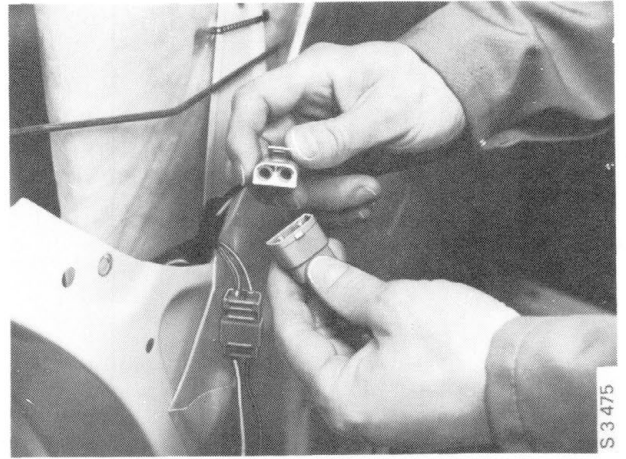

### Switches for rear-window heater and ventilation fan.

The switches for the rear-window heater and ventilation fan are fitted in the heater control panel.

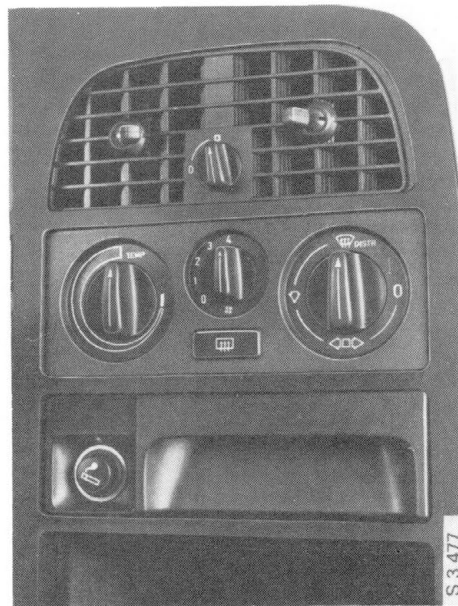

### To remove the rear-window heater switch

- 1 Remove the control knobs.

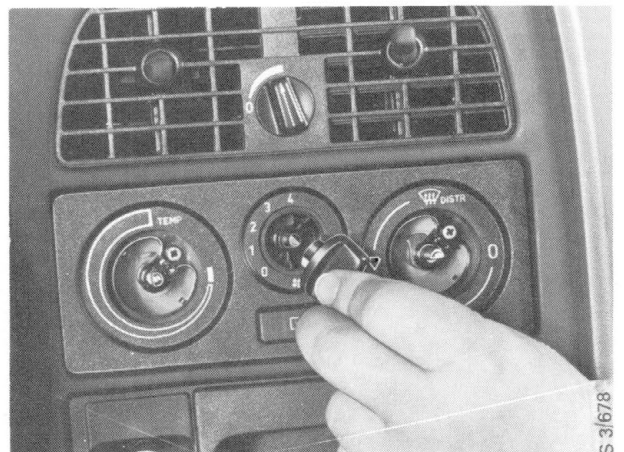



2 Remove the panel retaining screws.

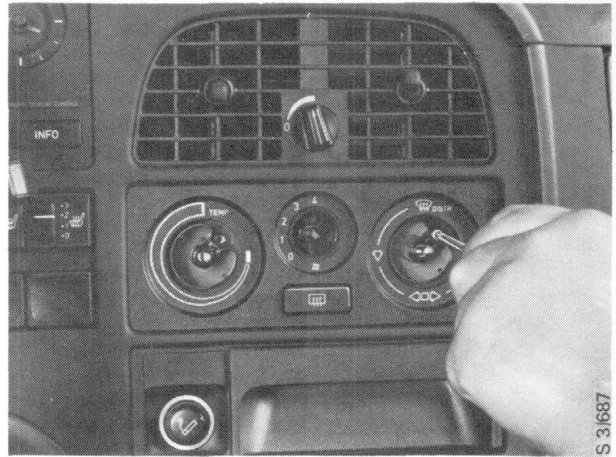

3 Remove the front panel.

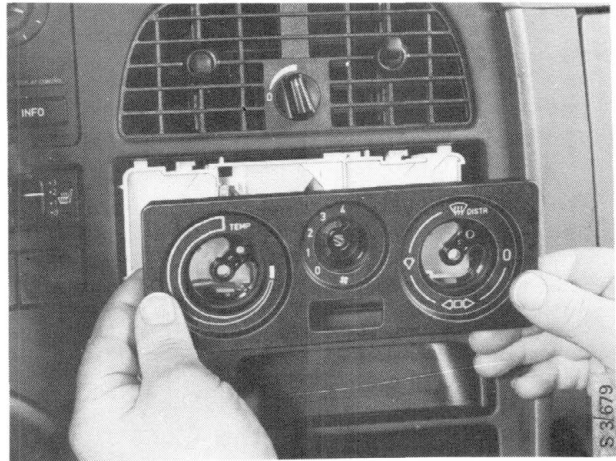

4 Withdraw the switch and disconnect the connector.



## To remove the switch for the ventilation fan.

For instructions for removing the control panel, see Group 8, Section 854 "Heating and ventilation".

- 1 The ventilation fan switch and master switch can now be removed.

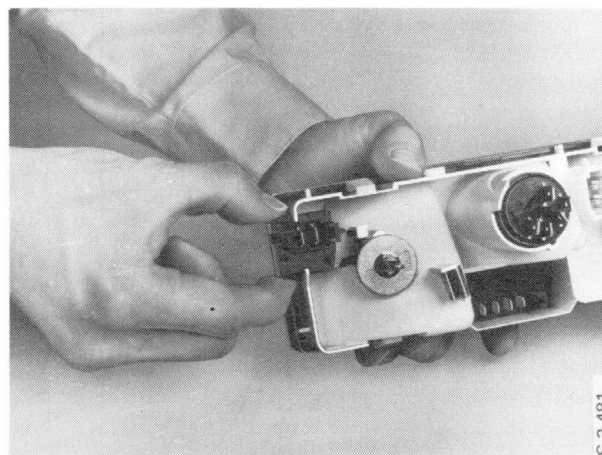
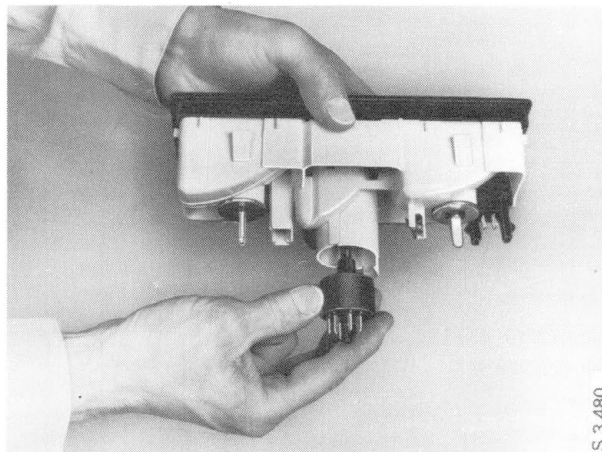

## Switch for luggage compartment illumination.

The switch for the luggage compartment lamp is a mercury switch, located inside the luggage compartment lid.

The switch is actuated by opening of the lid.

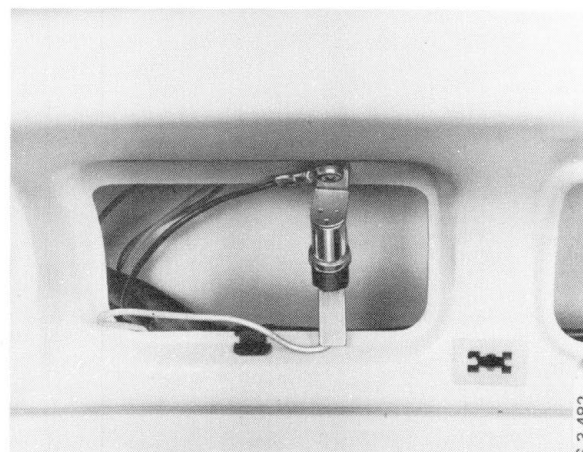

## Temperature switch for radiator fan.

The temperature switch for the radiator fan is fitted to the bottom right-hand corner of the radiator.

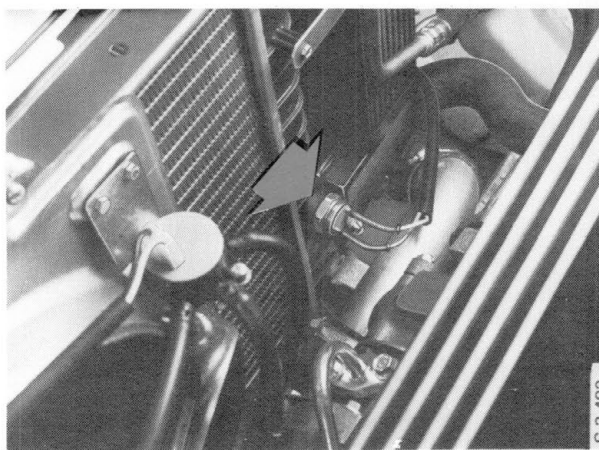

## Outside temperature transmitter (only on cars with EDU II trip computer)

The transmitter is located on the left-hand side of the spoiler.

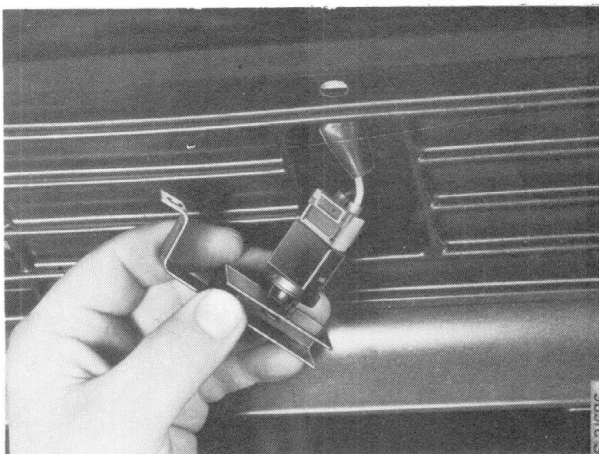

## Transmitter for electronic speedometer

The transmitter is located on the gearbox. To remove, disconnect the two-pole connector beside the windscreen wiper motor.

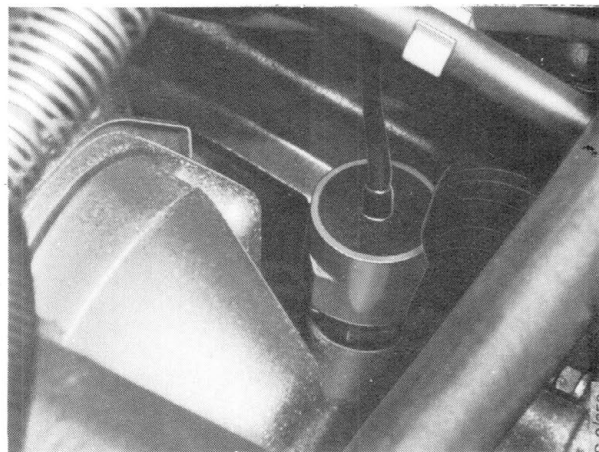

## Reversing light/shift-up indication switch

The reversing-light switch is fitted in the left-hand end cover on the gearbox.

The shift-up indication switch is fitted only to cars for the US market.

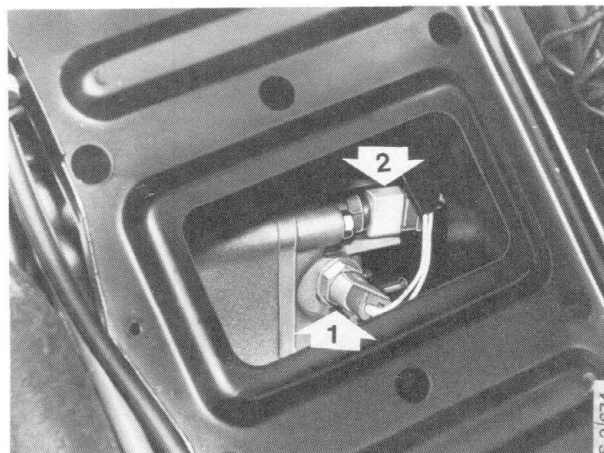

- 1 Shift-up indication switch(US)
- 2 Reversing light switch

# Factory-run wiring for the radio

Electrically operated aerial . . . . . 367-1

All cars are ready-wired at the factory, with all cables for the front and rear speakers, and for the power supply to the radio and to the electrically operated aerial run to a 10-pole connector in the centre console. The aerial cable is also run to the centre console. Some models have factory-fitted front and/or rear speakers, and an electrically operated aerial.

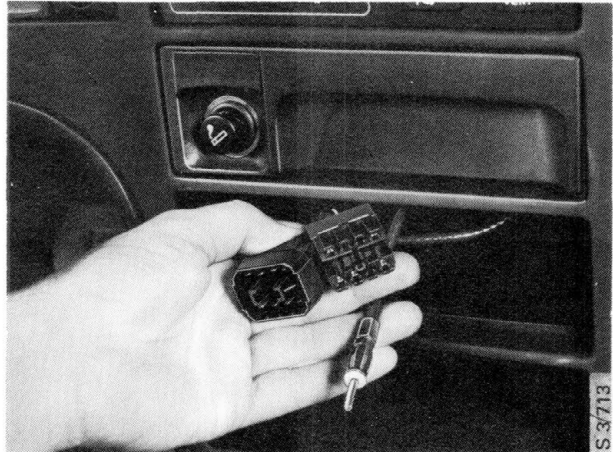

## Electrically operated aerial

### To remove

- 1 Remove the nut.

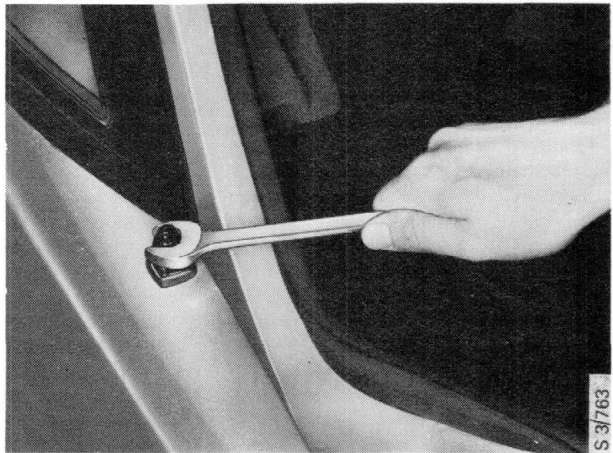

- 2 Remove the cover.



## 367-2 Factory-run wiring for the radio

---

- 3 Disconnect the two-pole connector and the aerial cable.
- 4 Remove the screws.



- 5 Remove the aerial downwards.

### **To fit**

Refit in the reverse order.

# Cruise control

Principle of operation . . . . . 368-1

## Principle of operation

The Cruise Control system enables the driver to preselect the speed of the car and then take his foot off the accelerator pedal, leaving the system to keep the car travelling at the preset speed. The driver sets the system by means of a switch on the direction-indicator stalk. The system will be switched out automatically if either the clutch pedal or brake pedal is depressed or if the switch is moved to the OFF position. The Cruise Control system can be used at speeds above 21 mph (34 km/h).

The main components of the system are the stalk switch, incorporating functions for SET SPEED, RESUME, OFF and ON, a speed sensor, vacuum pump, relay, electronic control unit, vacuum regulator and pedal switches.

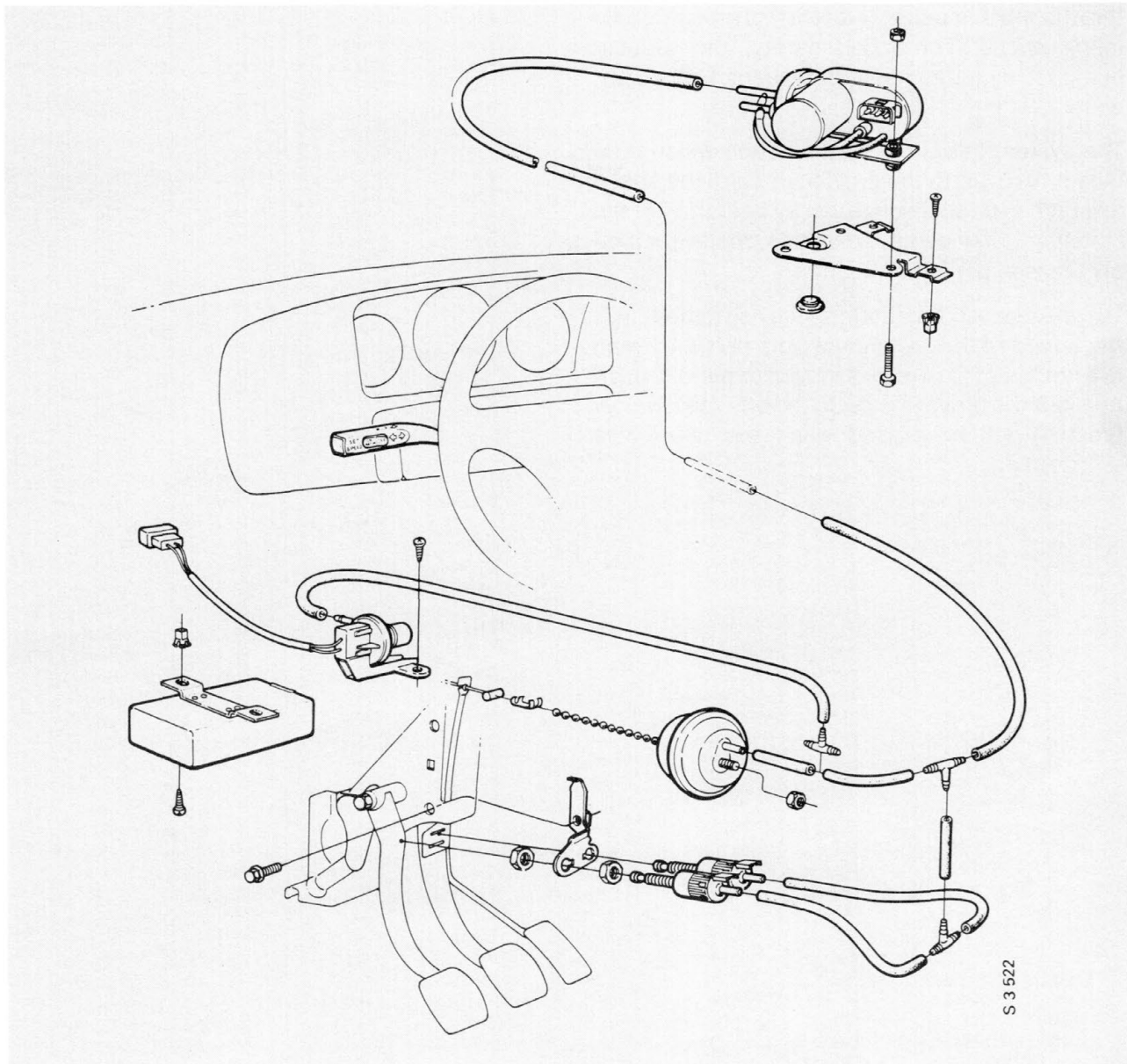

When the SET SPEED button is depressed, the signal transmitted by the speed sensor will be stored in the electronic control unit. The vacuum pump will start, drawing in the diaphragm in the vacuum regulator which, in turn, actuates the throttle cable. The throttle will then be set to the correct position for the preset speed.

The speed sensor senses any variations in the speed of the car and, via the electronic control unit, sends signals to the vacuum motor to raise or reduce the vacuum to keep the car travelling at the selected speed.

If the driver touches the accelerator pedal briefly to increase the speed of the car, the system will revert to the selected speed as soon as the accelerator is released.

If either the brake pedal or clutch pedal is depressed, the respective pedal switch will break the circuit, the vacuum will collapse and the throttle will immediately return to the position for idling speed. For added safety, the vacuum pump will simultaneously be switched off electrically.

The system has a memory function which enables it to revert to the previously selected speed after it has been disengaged by operation of the clutch or brake pedal. To do this, the driver simply presses the RESUME button.

The system will be automatically switched off if the speed of the car should drop below 21 mph (34 km/h), if the switch is moved to the OFF position or if the ignition is switched off. The memory function will be erased when the ignition is switched off.



### Cruise Control switch

The switch for the Cruise Control system is incorporated into the direction indicator stalk.

For instructions for removing the switch, refer to Section 361 "Direction indicators".

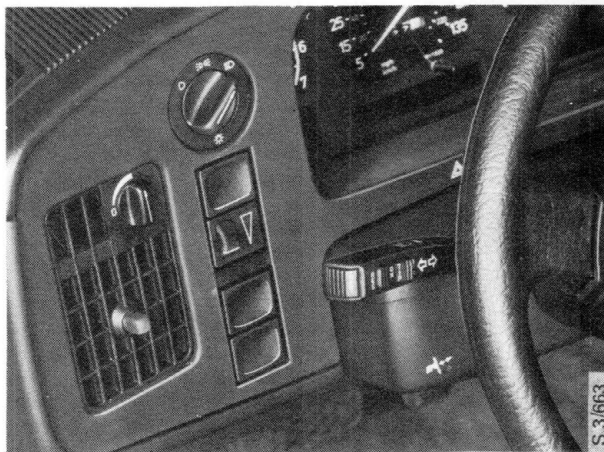

### Speed sensor

The speed sensor is located in the speedometer.

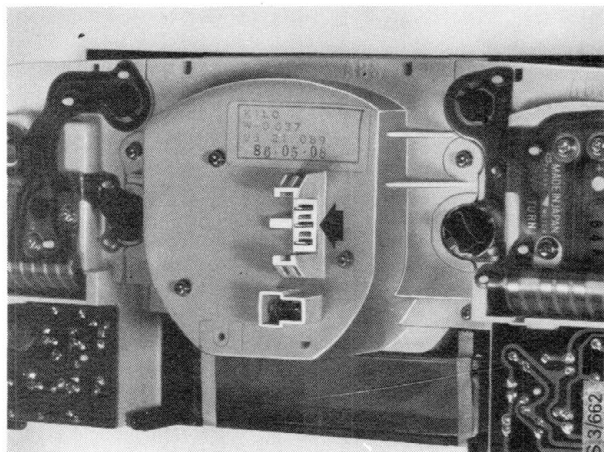

### Vacuum pump

The vacuum pump is located on the right-hand side in the engine compartment, adjacent to the ventilation air filter.

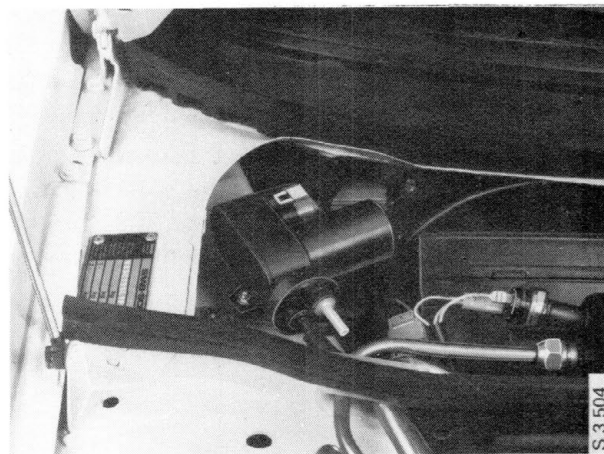

### Electronic control unit

The electronic control unit, vacuum regulator and pedal switches are located behind the knee shield, below the facia, on the left-hand\* side of the car. To gain access to these components, remove the knee shield below the facia. The electronic control unit is mounted on the same bracket as the control unit for the APC system.

An asterisk (\*) in the text indicates that the opposite hand applies to RHD cars.

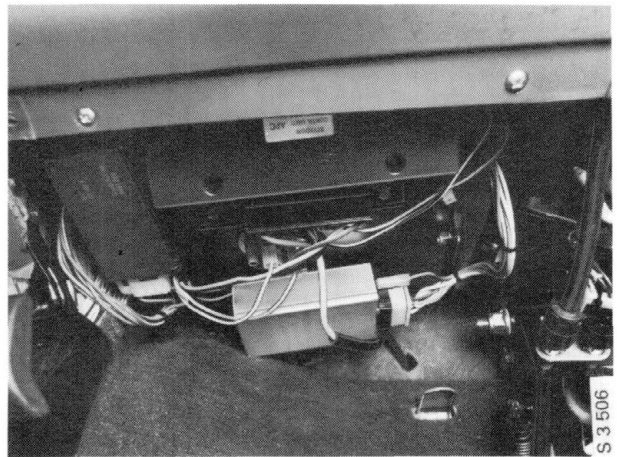
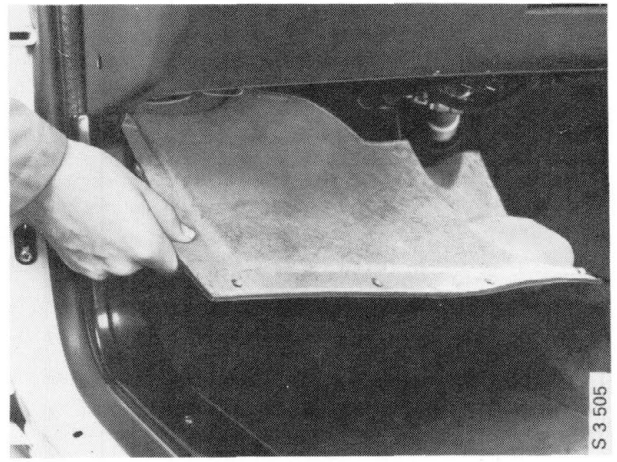

### Vacuum regulator

The vacuum regulator is fitted on a bracket beside the accelerator pedal mounting. When removing and fitting the regulator, take care not to damage the rubber gaiter. Fit the ball chain between the vacuum regulator and the throttle cable as tightly as possible, but without moving the throttle cable.

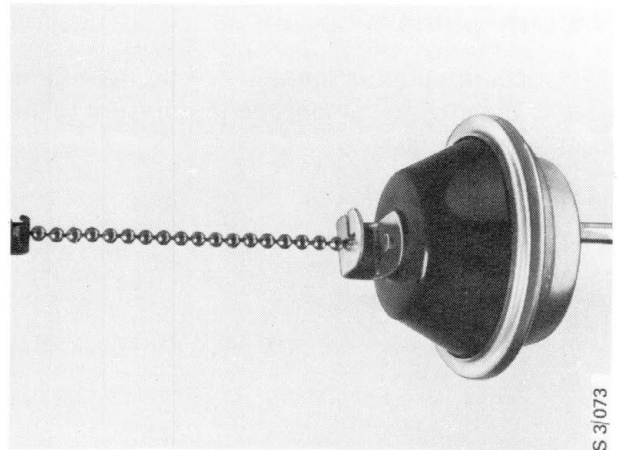

## Pedal switches

The pedal switches are fitted to the same bracket as the brake light switch. Adjust the switches so that there is clearance of  $1 \pm 0.5$  mm ( $0.04 \pm 0.02$  in) between the threaded part of the switch and the actuator button.

Make sure that the pedals are in the fully returned position before adjusting the clearance.

---

### **N.B.**

The pedal switches must **never** be adjusted so that they act as stops for the pedals.

---

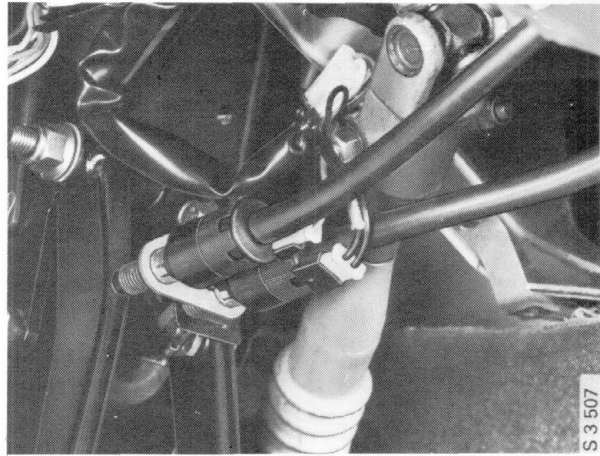

# Cables, fuses and relays

Cables . . . . .	371-1	Relays . . . . .	371-4
Fuses . . . . .	371-2		

## Cables

The wiring of the Saab 9000 consists of individual colour-coded and insulated cables bound together into cable harnesses which run from the electrical distribution box located behind the glove compartment. The electrical distribution box also houses the fuses and relays.

To avoid the risk of voltage drops due to poor contact in connectors, the wiring largely consists of continuous harnesses.

From the electrical distribution box, cable harnesses run to the engine compartment, the fascia, the interior of the car and the rear of the car. Two 8-pole connectors in the engine compartment join the cable harnesses for the engine to the remainder of the wiring.

All wiring connections are made by means of solder-free connectors, most of them of splash-proof design. These connectors cannot be repaired, and 200 mm long cables, complete with male or female connectors, are therefore available for repair work. If the cables are used in a system with a conductor area larger than 1.5 mm<sup>2</sup>, they should be shortened as much as possible. The cables should be connected to the existing cables by means of crimped connectors, which should be sealed with silicone. In the event of a problem in a circuit, check that the fault is not due to poor contact, and thus unnecessary voltage drop, in the relevant connector.

Should a fuse or fuses blow frequently, or if breakdown of the insulation is suspected, carry out an insulation test on the cable harness.

### N.B.

Remember that a short-circuit in the circuit between the power supply source and the fuse will not blow the fuse.

When fitting new cables, always make sure that the conductor area of the cable is suitable for the current it must carry and that the cable is suitably protected by grommets where it passes through sheet metal and where it is held by clips.

Wiring diagrams and a description of the operation of the different circuits and systems are given in the Service Manual, Group 3:2 "Electrical systems, Wiring diagrams".

### Fuses

The electrical system of the car is equipped with a number of fuses to protect the circuits from abnormal surges of current and to reduce the risk of fire due to short-circuiting, etc. The fuses are located in the electrical distribution box, behind the glove compartment. To gain access for checking or changing the fuses, fold down the cover in the top part of the glove compartment.

The fuses are of the plug-in type with two flat pins which plug into sockets in the electrical distribution box.

This type of fuse blows more quickly than conventional fuses, and the circuits are therefore more sensitive to short overloads. When changing a fuse, make sure that the new fuse is of the correct rating. If the rating is too low, the fuse will easily blow, whereas if the rating is too high, the components in the circuit may easily be damaged.

Fuses of the following ratings are used in the Saab 9000:

<i>Colour</i>	<i>Rating</i>
Red	10 A
Blue	15 A
Yellow	20 A
Transparent	25 A
Green	30 A

In addition to the colour coding, the rating is marked on each fuse.

### Checking the fuses

Every fuse is provided with two test tappings, to enable the fuse to be tested without the need to remove it. If both tappings are live, the fuse is intact.

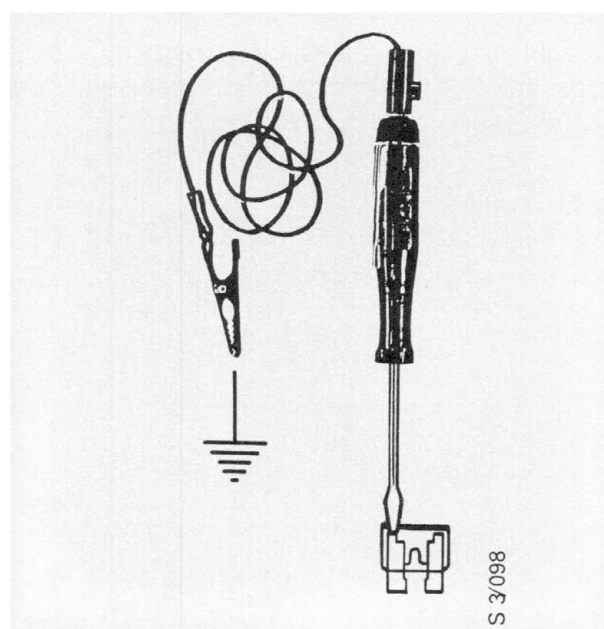
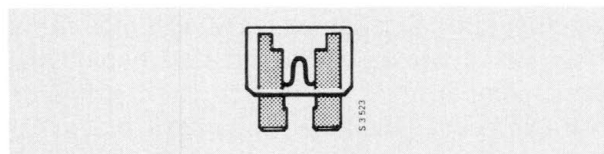

It is also possible to see whether a fuse has blown by removing it from the distribution box.

A special tool is provided on the lid of the electrical distribution box to facilitate the removal and fitting of fuses.

Fuse	Function	Rating (A)
1	Automatic Climate Control (ACC)	10
2	Cruise Control, electrically operated rear-view mirrors	10
3	Seat-belt warning lamp, instrument lighting, interior lighting	10
4	Air conditioner (AC)	30
5	APC system	10
6	Ventilation fan (ACC)	30
7	Headlamp wipers, horn, shift-up indicator	10
8	Windscreen wipers	15
9	Cigarette lighter, reversing lights, rear window regulators, electrically operated sunroof	25
10	Electric heating pads for the front seats	15
11	Front window regulators	30
12	Direction indicators	15
13	Instruments, fuel injection system, EDU	10
14	Fuel pump	20
15	Extra fog lamps	10
16	Central locking, interior lights, courtesy lights, luggage compartment illumination	15
17	ACC, clock	10
18	Heater element for the rear window	30
19	Radio, electric aerial	15
20	AC radiator fan, compressor	30
21	Horn	10
22	Hazard warning lights, burglar alarm	15
23	Radiator fan	25
24	Brake lights	15
25	Headlamp dipped beam, right-hand	15
26	Headlamp dipped beam, left-hand	15
27	Headlamp full beam, right-hand	15
28	Headlamp full beam, left-hand	15
29	Parking lights, right-hand	10
30	Parking lights, left-hand, glove compartment illumination	10
31	Corner lights, dim dipped beams	15
32	Rear fog lights	15

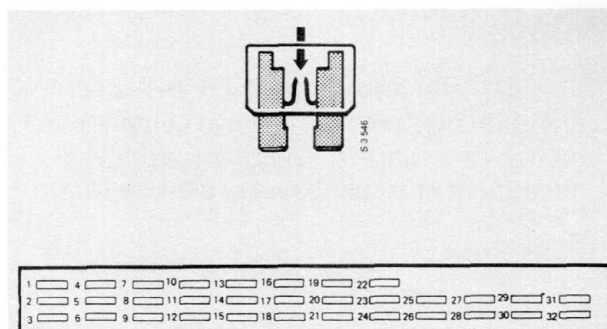

Locations of the fuses in the electrical distribution box.

## Relays

The relays are also located on the electrical distribution box behind the glove compartment. To check or replace a relay, remove the glove compartment and pull the relay board forward.

Location	Component No.	Function
A	82	Seat belt warning (US)
B	228	Filament monitor
C	68	Horn
D	113	Electric heater element for the rear window
E	156	AC compressor
F	155	AC radiator fan
G	21	Ignition switch relay
H	229	Fuel injection system
I	102	Fuel pump
J	147	Ignition pulse amplifier
K	8	Main lights
L	83	Intermittent operation of the windscreen wipers
M	151	Time delay for the interior lighting
N	23	Flasher relay
O	270	Shift-up indication (US)
1)	26	Time delay relay, radiator fan
1)	78	Relay, dim dipped beams (GB)
1)	107	Relay, extra fog lamps (US)
1)	259	Relay, dim dipped beams (GB)

- 1) The relays are located on an additional relay board, on the right-hand side of the distribution box.

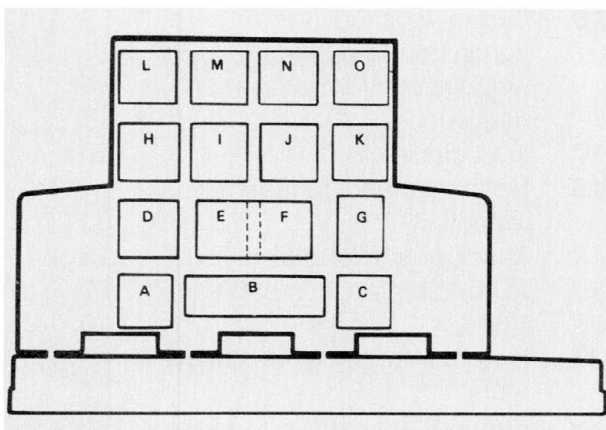
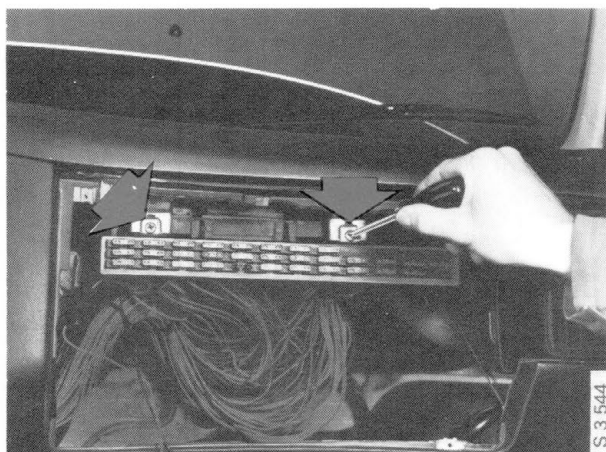
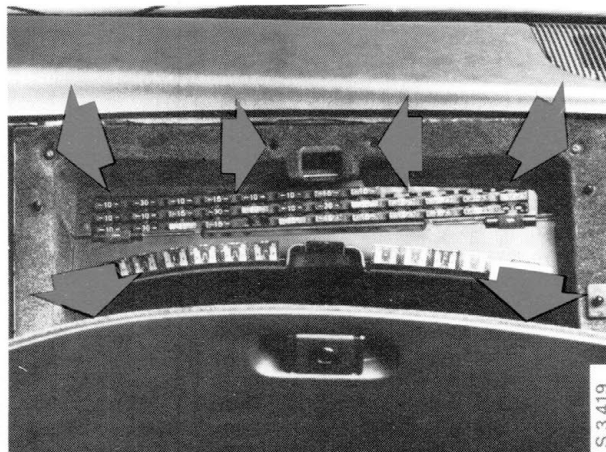

Locations of the relays in the electrical distribution box.

**Relay for the electrically operated sun-roof**

The relay is located in the roof console, behind the cover.

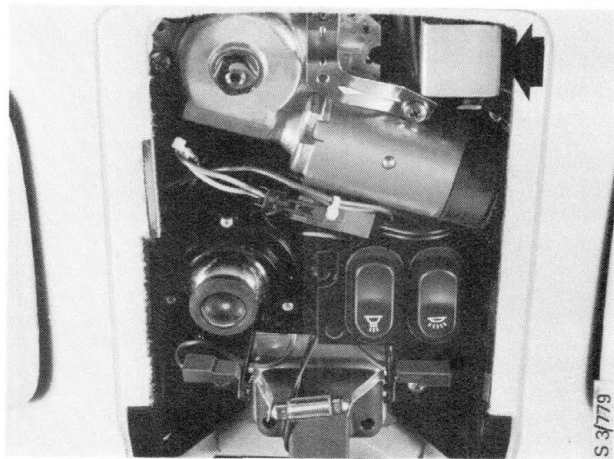

**Relay for automatic window regulator control**

The relay is located under the driver's seat.

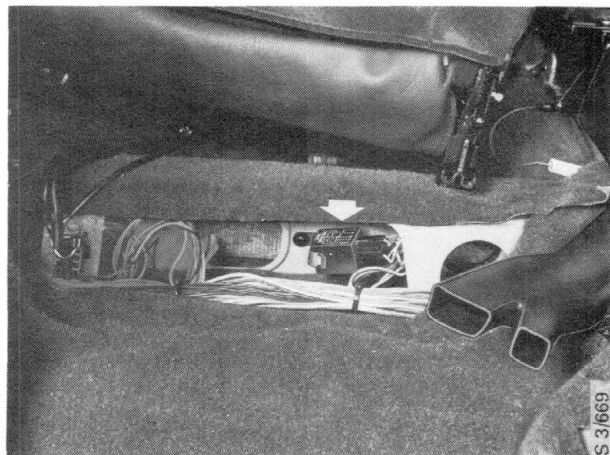



# Instruments

Principle of operation . . . . .	381-1	DCC trip computer . . . . .	381-7
EDU 1 trip computer . . . . .	381-3	To remove the combined instrument . . . . .	381-16
EDU 2 trip computer . . . . .	381-5		

## Principle of operation

The Saab 9000 is equipped with a combined instrument, located centrally in front of the driver.

The arrangement of the instruments is as follows: The three main instruments are, from left to right, the tachometer, the speedometer and the combined temperature gauge, turbocharger boost pressure gauge and fuel gauge.

The repeater lamps for the direction indicators are located at the top of the panel, within the driver's natural field of view.

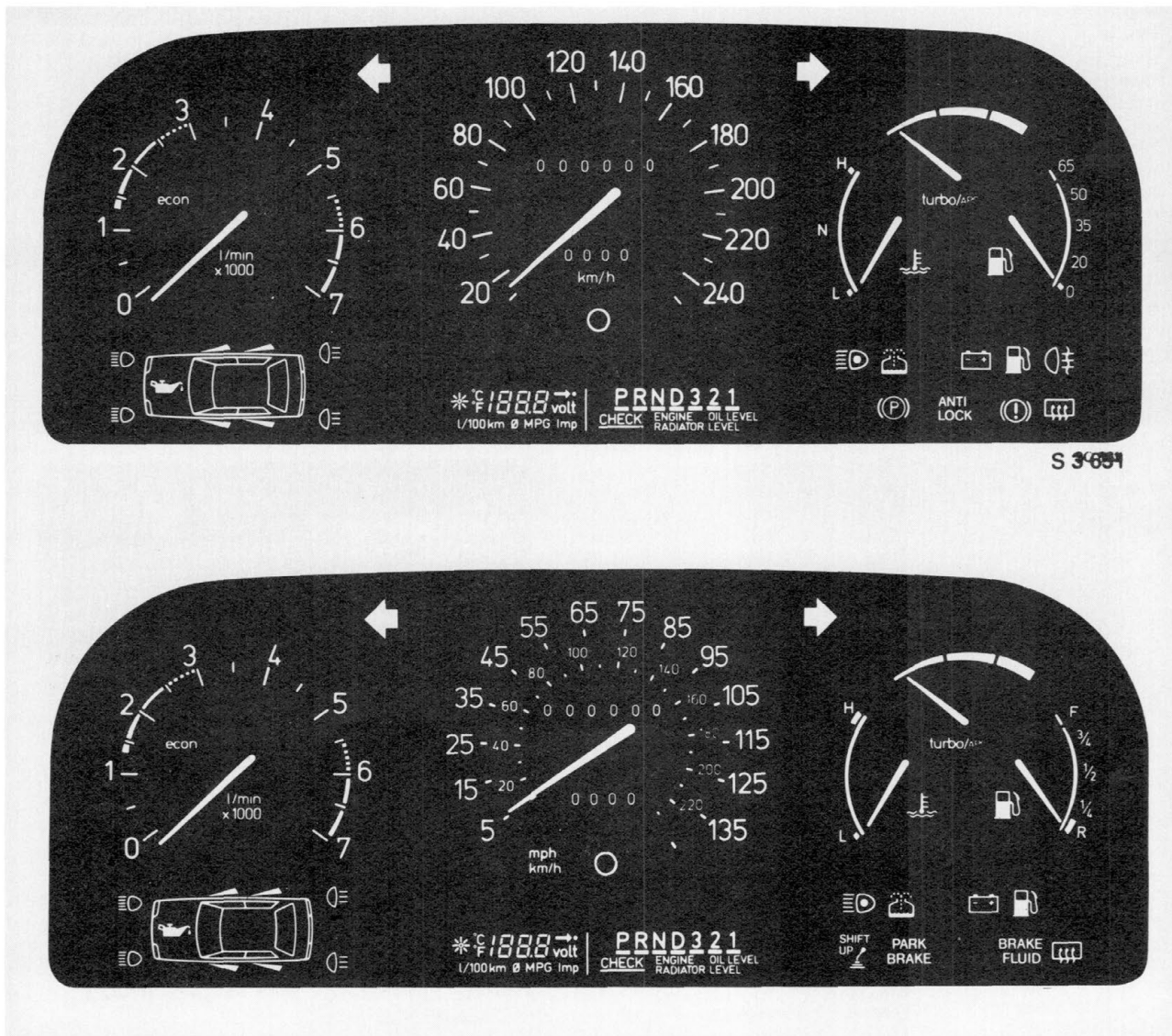

## 381-2 Instruments

Below the tachometer is the pictogram, which will warn the driver if any of the front or rear lights should fail or if any of the doors is not properly closed. The pictogram also includes an oil pressure warning lamp. The pictogram, which displays an image of the car viewed from above, always lights up when the ignition is switched on, but is then extinguished if no faults are detected. If a fault should occur while the car is travelling, the relevant symbol will light up on the display.

On cars for the EU market, the warning lamp for the rear lights will remain alight until the brake pedal has been depressed once after the engine has been started.

An LCD display is located directly below the speedometer.

An array of warning lamps for full beam, hand-brake on, low oil pressure, low charging current, etc. is located on the bottom right-hand side of the instrument panel.

The arrangement and location vary depending on the market for which the car is intended.

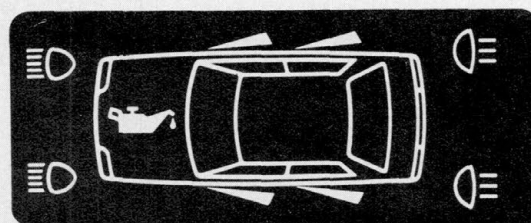

S G 549

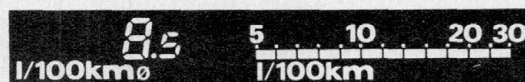

EDU 1

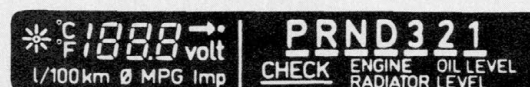

EDU 2

S 3 688



S 3/777

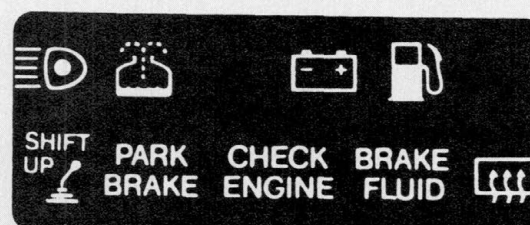

S 3/778

## EDU 1 trip computer

The trip computer consists of two parts, i.e. buttons (marked "R" and "INFO") located below the clock and a display located below the speedometer.

The trip computer provides information on:

- Battery voltage
- Average fuel consumption
- Instantaneous fuel consumption.

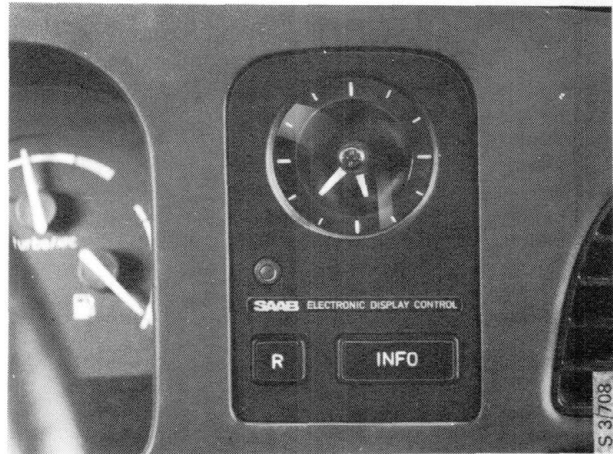

### Battery test

When the ignition is switched on, the trip computer will display the battery voltage. While the engine is being started, the lowest measured voltage will be recorded, and this value will be displayed until the car pulls away. The computer will then revert to displaying the value selected previously. This arrangement provides information on the condition of the battery.

### Changing the information displayed

The information shown on the digital part of the display can be changed from the battery voltage to the average fuel consumption or vice versa by depressing the "INFO" button.

The bar chart on the right-hand side of the display always shows the instantaneous fuel consumption.

### To change the units displayed

The fuel consumption can be displayed either in litres per 100 km, or in miles per U.S. gallon (MPG), or in miles per Imperial gallon (MPG). This change can be done by briefly depressing twice the "R" button. The button must be depressed in quick succession (within half a second).

The units are changed in the following order:

- litres/100 km
- miles/U.S. gallon (MPG)
- miles/Imperial gallon (MPG)

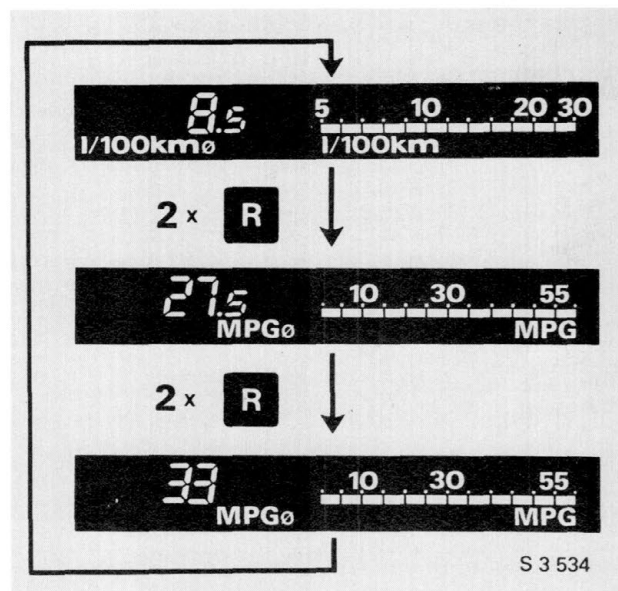

### **Reset**

To reset the distance and the average fuel consumption, depress the "R" button. The button must be kept depressed for at least two seconds. This is equivalent to switching on the power supply.

When the button is released and the car has travelled for about 200 metres (0.12 miles), the information will be reset to zero. This will be indicated by the average fuel consumption being replaced by two horizontal dashes.

If the correct average fuel consumption is to be displayed, the trip computer must be reset every 3000 km (1865 miles). The trip computer thus cannot calculate the average consumption over a longer continuous distance than about 3000 km (1865 miles).

### **To switch off the display**

If no information is required, the display can be partially or entirely switched off by depressing the "R" and "INFO" buttons simultaneously. The buttons must be kept depressed for at least two seconds.

The information will be switched off and on in the following order:

- when the buttons are first depressed, the bar chart will be switched off.
- when the buttons are depressed a second time, the digital part will also be switched off and the display will be completely blank.
- when the buttons are depressed a third time, the bar chart will be switched on.
- when the buttons are depressed a fourth time, the digital part will also be switched on and the display will again be fully operative.

## EDU 2 trip computer

The trip computer can be controlled by means of two buttons marked "R" and "INFO". The buttons are located below the clock. A sensor beside the buttons adjusts the brightness of the display to suit the prevailing light conditions in daylight. At night, the brightness of the display can be regulated with the same rheostat button which controls the brightness of the instrument lighting.

The trip computer gives the following information :

### Left-hand part of the display:

- Fuel consumption (instantaneous and average).
- Battery voltage (and battery condition).
- Range on remaining fuel.
- Outside temperature.

### Upper right-hand part of the display:

- Indication of which gear is engaged (cars with automatic transmission).

### Lower right-hand part of the display:

- "Check Engine" warning text.
- "Check Oil Level" warning text.
- "Check Radiator Level" warning text.

### Battery test

When the ignition is switched on, the trip computer will display the battery voltage. While the engine is being started, the lowest measured voltage will be recorded, and this value will be displayed until the car pulls away. The computer will then revert to displaying the value selected previously. This arrangement provides information on the condition of the battery.

### Changing the units

The information in the left-hand part of the display can be obtained in the following units:

- km, °C and litres.
- miles, °F and U.S. gallons.
- miles, °F and Imperial gallons (marked Imp).

To change from one system to another, keep the "R" and "INFO" buttons depressed simultaneously for at least four seconds.

### Changing the information displayed

To change the information displayed in the left-hand part of the display, press the "INFO" button. The information will then be displayed in the following order and with the following signs:

- Average fuel consumption (l/100 km Ø, Ø MPG, Ø MPG Imp).
- Instantaneous fuel consumption (l/100 km, MPG, MPG Imp).
- Range (.km, .mi, .mi).
- Outside temperature (°C, °F, °F).
- Battery voltage (Volt).
- The calculation of the average fuel consumption is based on the distance travelled and the fuel consumed since the distance travelled was last reset to zero. After the distance travelled has been reset, three horizontal dashes will appear in the display until the car has travelled 200 metres (0.12 miles). If the system is not reset manually, it will be reset automatically when the total fuel consumption has reached 1342 litres (1412 qts), or the distance travelled has reached 10 480 km (6513 miles).
- The range is calculated on the basis of the fuel remaining in the tank and the average fuel consumption during the last 10 minutes of driving (with the ignition switched on).
- The outside temperature is measured between -40°C (-40°F) and +50°C (+121°F).

### **Reset**

To reset the average fuel consumption and the range on remaining fuel, depress the "R" button and keep it depressed for at least four seconds. Reset is acknowledged by all figures in the left-hand lighting up until the button is released.

### **Gear indication**

On cars with automatic transmission, the gear which is engaged is displayed in the right-hand upper part of the display.

### **Warning text**

The warning text in the lower right-hand part of the display has the following significance:

- "Check Engine" is connected to the fuel injection system. It indicates unsatisfactory performance of certain parts of the system, e.g. filament failure.
- "Check Oil Level" lights up when the engine needs to be topped up with at least 0.5 litres (0.5 qts) of oil. The oil level is monitored when the ignition is switched on, and not when the car is travelling. The ignition must be switched off for at least five minutes before a new measurement can be taken.
- "Check Radiator Level" lights up when the coolant level in the expansion tank is too low. The coolant level is monitored continually when the ignition is switched on.

### **Fault indication**

The trip computer contains an automatic fault-tracing system. Fault codes in the left-hand part of the display provide information in the event of a fault occurring in certain parts of the system. The monitoring takes place automatically and the fault code remains on display until the fault has been cleared.

The fault codes which are used are as follows:

- F1 Gear indication switch or wiring faulty (only cars with automatic transmission).
- F2 Short-circuit in the outside temperature sensor.
- F3 Short-circuit in the fuel level sensor.
- F4 Possible malfunction of the trip computer unit.

## DCC trip computer

The DCC trip computer comprises the following functions:

- Temperature functions
  - Outside temperature
  - Interior heater timer 1
  - Interior heater timer 2
- Time functions
  - Clock
  - Elapsed time
  - Stopwatch
  - Alarm
- Trip functions
  - Trip meter
  - Distance to destination
  - Speed warning alarm
  - Average speed

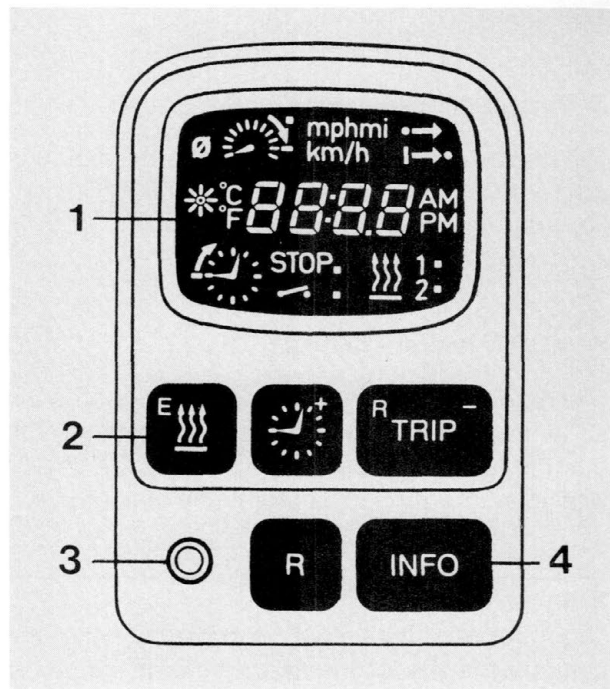

- 1 Display
- 2 Buttons for the DCC
- 3 Sensor for automatic brightness control
- 4 Buttons for the EDU (Display below the speedometer)

To change over to a different function, depress briefly the appropriate button. Every function has a number of sub-functions, as shown in the table below. Increment to the required sub-function by depressing repeatedly the appropriate button. The relevant sub-function is shown by symbols in the display.

### N.B.

Before switching on and off, resetting or the like, always increment to the appropriate sub-function.

If the power supply to the DCC computer has been switched off, all starting times, etc. must be set afresh.

## Changing the units

The DC can be programmed to display either units A or units B.

A km, km/h, °C and 24-hour clock.

B miles, mph, °F and 12-hour clock (a.m. and p.m.)

To change over from one set of units to the other, hold these three buttons depressed at the same time for at least 4 seconds.

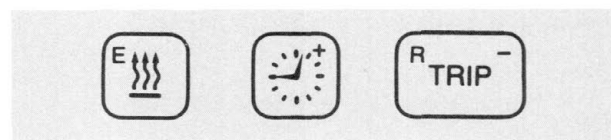

## Temperature functions

### A Outside thermometer

The function displays the outside temperature in degrees Celsius or degrees Fahrenheit (°C or °F). For instruction for changing between °C and °F, see under "Changing the units".

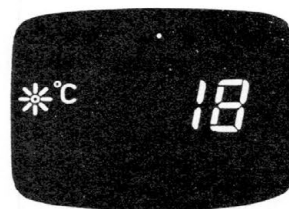

### B Interior heater - timer 1\*

The required time at which the interior of the car should be warm can be preset. By sensing the outside temperature, the system will then decide when the interior heater should be started.



#### N.B.

The timer functions must be activated when the computer is set for the first time or if the power supply has been switched off. See under "Activating and deactivating the timer functions for the interior heater".

Proceed as follows:

- 1 Hold this button depressed for at least 2 seconds.
- 2 Keep depressing the appropriate button to increment (increase) or decrement (decrease) the left-hand pair of figures until they show the required hour of the day.
- 3 Then briefly depress this button ...
- 4 ... and repeat the procedure for the right-hand pair of figures to set the minutes.
- 5 End the entry by depressing this button briefly.

The interior heater will now start once (within 24 hours).

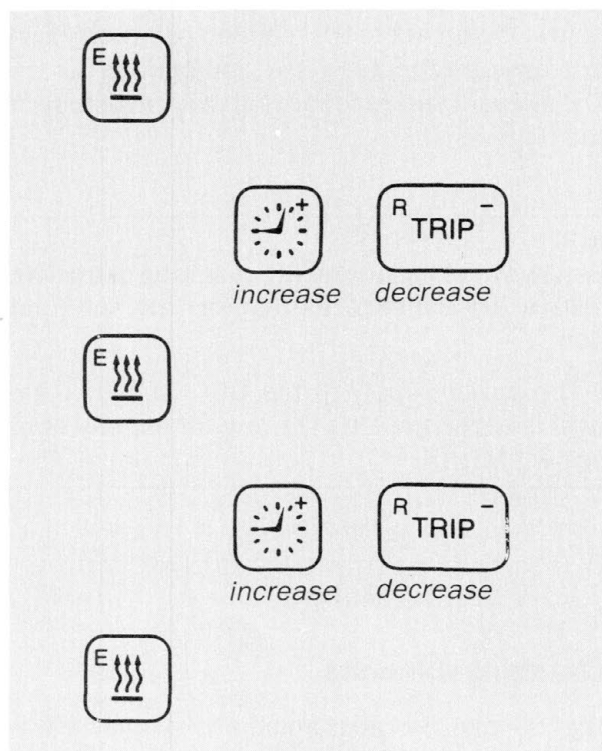



- 6 The "Interior heater timer 1" function can be activated or deactivated by depressing these two buttons briefly at the same time.

Indication that the function has been activated is provided by a small square lighting up to the right of the symbol in the display.

The next time preheating of the interior is required at the same time, increment to the appropriate sub-function and follow the procedure described in 6 above.

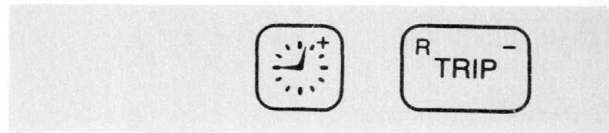

### C Interior heater - timer 2\*

The procedure and function is the same as for "Interior heater timer 1".

- \*) The interior heater can also be started and stopped manually.
- 1 Manual starting and stopping outside the DCC programme: Hold these buttons depressed at the same time for at least 4 seconds until the heater symbol in the display lights up (or is extinguished).
  - 2 Manual tripping when the heater has been started by the DCC timer:  
To deactivate the timer, briefly depress these two buttons at the same time.

N.B. The heater will stop a few minutes after it has been deactivated.

If the car is not equipped with an interior heater, functions B and C can be erased from the display, but can be recalled if required at a later date.

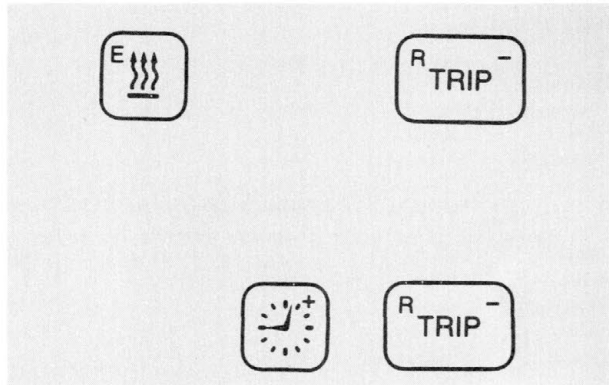

### Activating and deactivating the timer functions for the interior heater

- 1 To activate or deactivate the timer functions, hold these two buttons depressed at the same time for at least 8 seconds, until the heater symbols light up (or are extinguished) in the display.

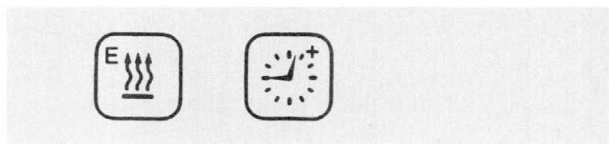

## Time functions

### A Clock

The clock can be set to display the time in the 24-hour or 12-hour system. For further particulars, see the section entitled "Changing the units".



Set the clock as follows:

- 1 Start by holding this button depressed for at least 2 seconds. The left-hand pair of figures will then start to flash.
- 2 Keep depressing the appropriate button to increment (increase) or decrement (decrease) the hour reading.
- 3 Briefly depress this button ...
- 4 ... and repeat the procedure on the flashing right-hand pair of figures to set the minutes.
- 5 After setting the clock, depress this button briefly.

N.B. Press the button at the correct instant (e.g. using the radio time signal). The clock will then show the correct hour and the correct minute - to the second.

The clock will show the right time even if the ignition is switched off. To read the time, press this button.

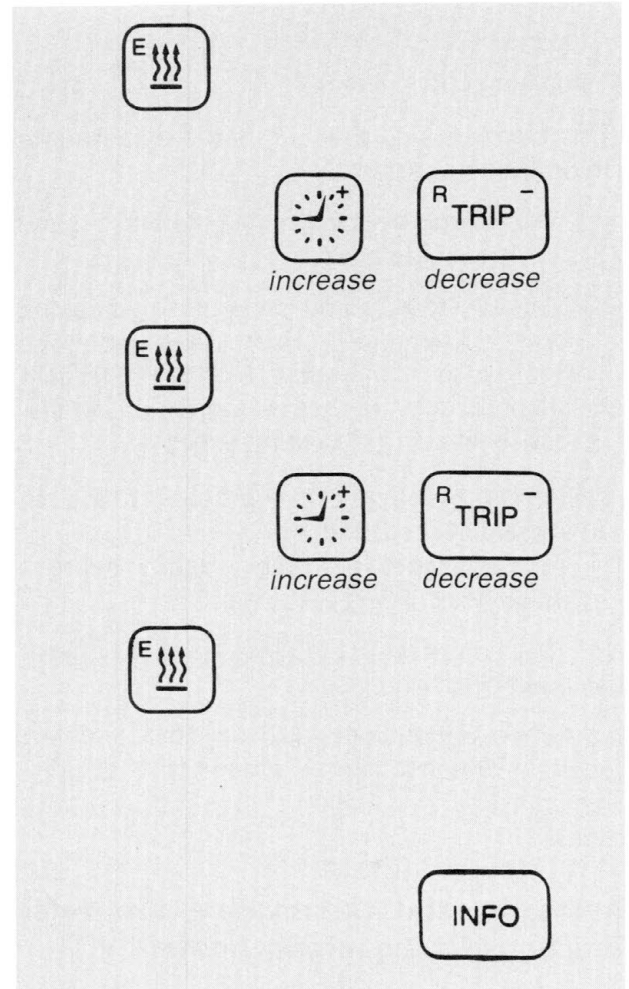

**B Elapsed time**

Hours and minutes are first displayed up to 99 hours and 59 minutes, and then hours only up to 199 hours. The time (and the trip meter) will then be automatically reset to zero.

- 1 Reset the time to zero by depressing this button. Keep the button depressed for at least 4 seconds, until all display segments light up. Timing will then start at the instant when the button is released.

**N.B.**

This will also reset the trip meter and the average speed.

The timer will run as long as the ignition is switched on, regardless of whether the car is travelling or stationary.

**C Stopwatch**

The stopwatch function starts by counting minutes and seconds up to 59:59 - and then hours and minutes up to 99:59.

- 1 The stopwatch function can be reset to zero by holding this button depressed for at least 2 seconds.
- 2 The stopwatch function can then be started and stopped by depressing briefly these two buttons at the same time.

Indication that the stopwatch is operative and that counting is in progress is provided by a small square lighting up to the right of the STOP symbol in the display.



**D Alarm**

The alarm signal consists of 5 short bleeps, and the alarm is then switched off automatically.

Set the alarm time as follows:

- 1 Hold this button depressed for at least 2 seconds. The left-hand pair of figures will then start to flash.
- 2 Keep depressing the appropriate button to increment (increase) or decerement (decrease) the hour reading.
- 3 Briefly depress this button...
- 4 ... and repeat the procedure to set the minutes (right-hand pair of figures).
- 5 End the entry by depressing this button briefly.  
The alarm will now sound once at the preset time (within 24 hours).
- 6 Activate (or cancel) the alarm function as follows: Briefly depress these two buttons at the same time.

Indication that the alarm function has been activated is provided by a small square lighting up to the right of the symbol in the display.

The next time the alarm is required at the same time, increment to the appropriate sub-function and follow the procedure described in 6 above.

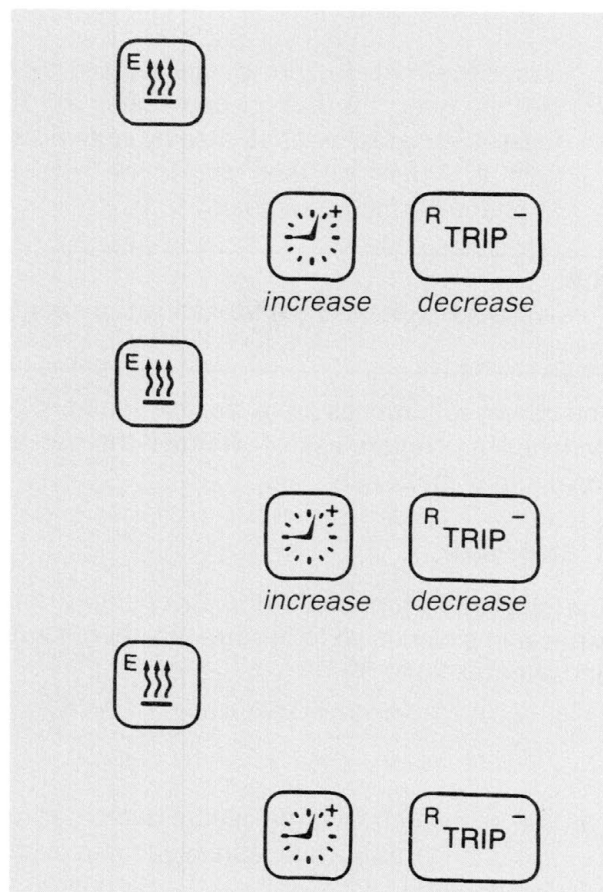

## Trip functions

### A Trip meter



- 1 Reset the trip meter to zero by holding this button depressed for at least 4 seconds, until all display segments light up.



### N.B.

This will also reset the elapsed time and the average speed.

The distance travelled will now be recorded in km and tenths of km up to 999.9 km, and then only in km up to 9999 km (or 619.9 miles and 6199 miles respectively).

When this maximum value has been reached, the trip meter and the elapsed time functions will automatically be reset to zero and counting will start afresh.

The trip meter can be re-calibrated if tyres of a different size have been fitted to your car (see the section entitled "To calibrate the trip meter").

### B Distance to destination

If the distance is less than 1000 km, the function will record km and tenths of km. It will then record km only up to a maximum of 9999 km (or 620 miles and 6199 miles respectively).



- 1 Start the entry by holding this button depressed for at least 2 seconds.
- 2 Keep depressing the appropriate button to increment (increase) or decrement (decrease) the flashing left-hand group of figures until they show the distance (in km or miles).



increase



decrease

- 3 Briefly depress this button ...
- 4 ... and repeat the procedure for the flashing right-hand figure by repeatedly pressing the appropriate button.
- 5 End the entry by briefly depressing this button.

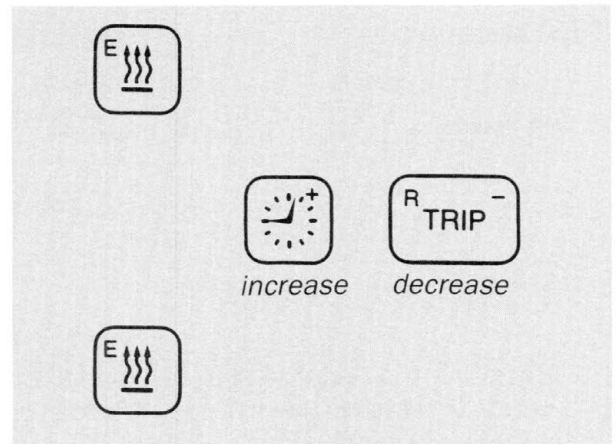

## C Speed warning alarm

The DCC will bleep briefly every eighth second when the car is travelling at a speed above the preset value.

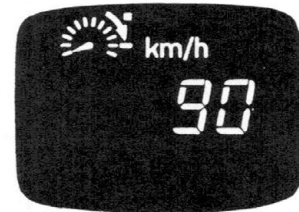

Enter the required speed limit as follows:

- 1 Hold this button depressed for at least 2 seconds, and the left-hand group of figures will then start to flash.
- 2 Keep depressing the appropriate button to increment (increase) or decrement (decrease) the left-hand group of figures.
- 3 Then briefly depress this button ...
- 4 ... and repeat the procedure for the right-hand group of figures by repeatedly pressing the appropriate button.
- 5 End the entry by depressing this button briefly.
- 6 The speed warning alarm can be activated or deactivated by depressing briefly these two buttons at the same time.

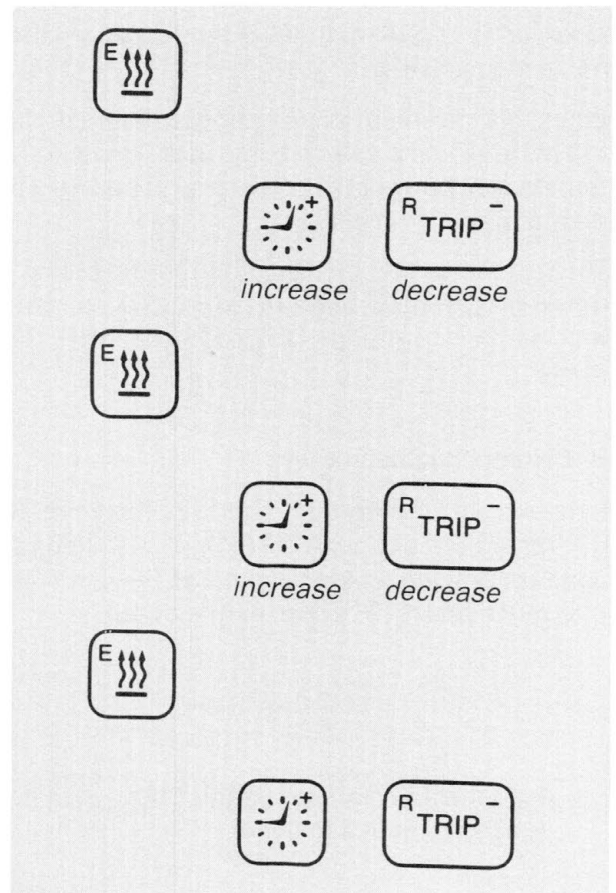

Indication that the speed warning alarm has been activated is provided by a small square lighting up to the right of the symbol in the display.

**D Average speed**

The average speed is calculated as the distance recorded by the trip meter, divided by the time taken to cover the distance.

- 1 Reset the trip meter to zero by keeping this button depressed for at least 4 seconds, until all display segments light up.

**N.B.**

This will also reset the elapsed time and the trip meter.

Immediately after resetting, the instantaneous speed of the car will be displayed for about 3 minutes, followed by the average speed (the symbol will be displayed).

**To calibrate the trip meter**

If the size of tyres fitted to your car is changed, the outside diameter of the wheel will be different, and the trip meter can then be recalibrated as follows:

- 1 Reset the trip meter to zero by holding this button depressed for at least 4 seconds.
- 2 Drive the car for a well-defined distance of a few tens of kilometres. If the trip meter reading deviates from the actual distance, enter the correct distance as described below. N.B. The DCC will not accept corrections larger than 10%.
- 3 Hold this button depressed for at least 2 seconds.
- 4 Keep depressing the appropriate button to increment (increase) or decrement (decrease) the flashing left-hand group of figures.
- 5 Briefly depress this button ...



increase

decrease



6 ... and repeat the procedure on the flashing right-hand group of figures.

7 End the correction by depressing this button briefly.

The functions of the bottom row of buttons on the DCC unit are described in the section entitled "EDU 2 trip computer".

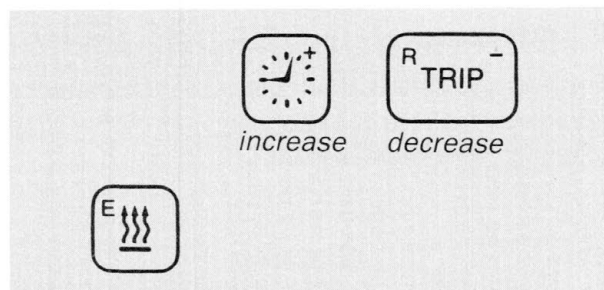

### To remove the combined instrument

1 Disconnect the negative (-) battery cable.

---

#### **N.B.**

**Never** disconnect the battery when the engine is running, since serious damage to the alternator may result.

---

2 Remove the speaker grilles on both sides of the facia.

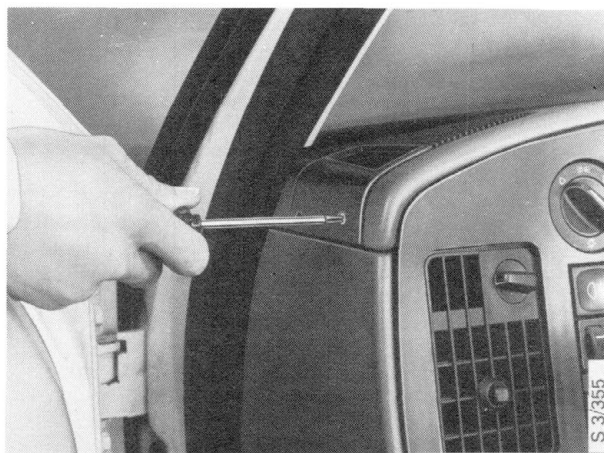

3 Remove the seven screws (including one in the glove compartment) securing the top section of the facia.

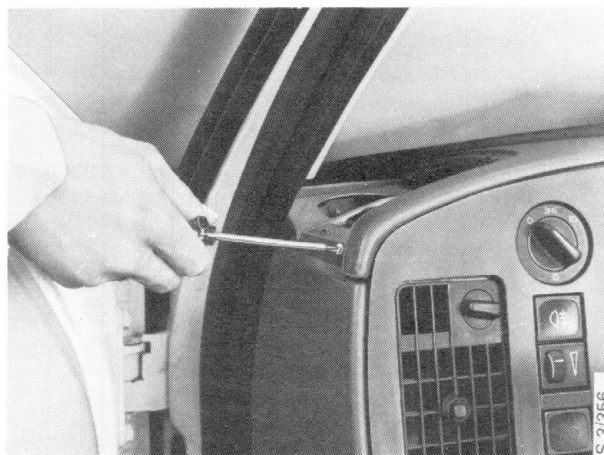



4 Lift off the top section of the facia.



S 3/357

5 Remove the air duct.



S 3/358

6 Disconnect the vacuum hose to the boost pressure gauge and unplug all connectors to the combined instrument.

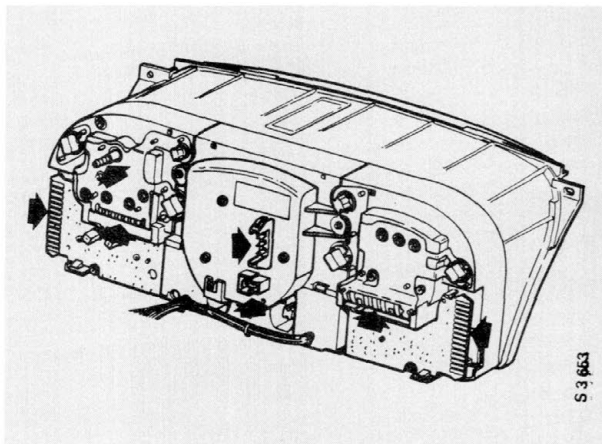

S 3 963

7 Remove the two screws and remove the combined instrument.



S 3/359

**To fit**

Refit in the reverse order.

**N.B.**

When refitting the air duct, make sure that it fits correctly into the connections.

### To remove the clock/DCC (cars without ACC)

- 1 Disconnect the negative (-) battery cable.

---

#### **N.B.**

**Never** disconnect the battery when the engine is running, since serious damage to the alternator may result.

---

- 2 Remove the speaker grilles on both sides of the facia.

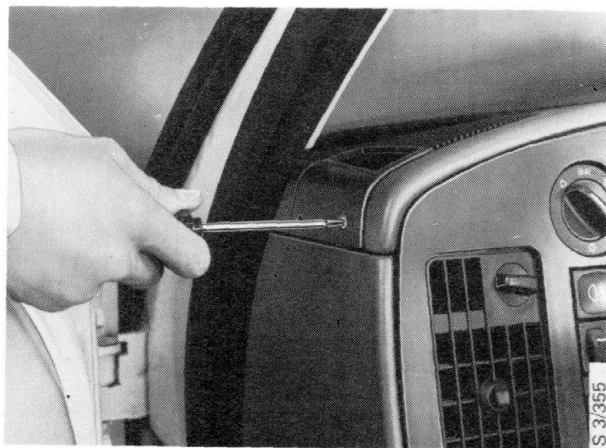

- 3 Remove the seven screws (including one in the glove compartment) securing the top section of the facia.

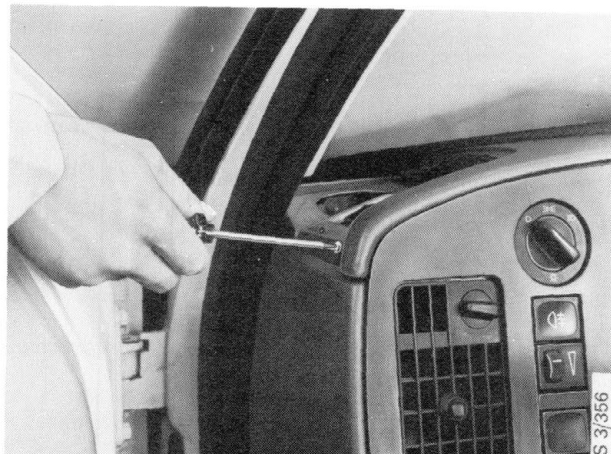

- 4 Lift off the top section of the facia.



- 5 Disconnect the electrical connectors from the clock and press the clock out of its mounting.

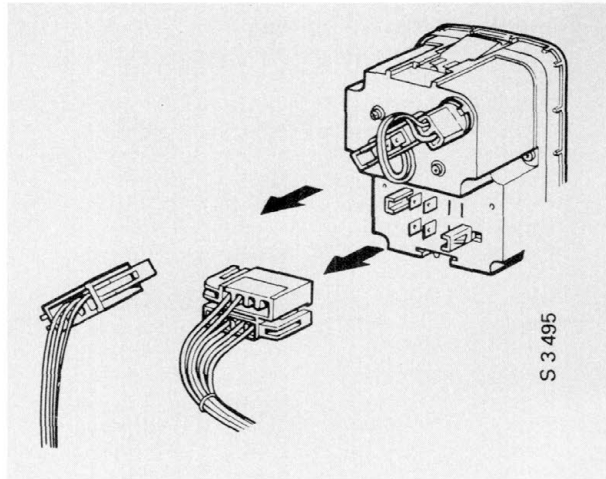

**To remove the clock/DCC (cars with ACC)**

- 1 Remove the ashtray.

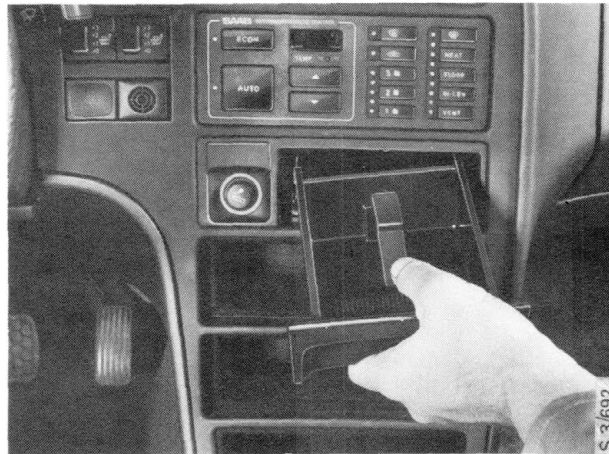

- 2 Bend down the two upper locking tabs and withdraw the ashtray holder forward.

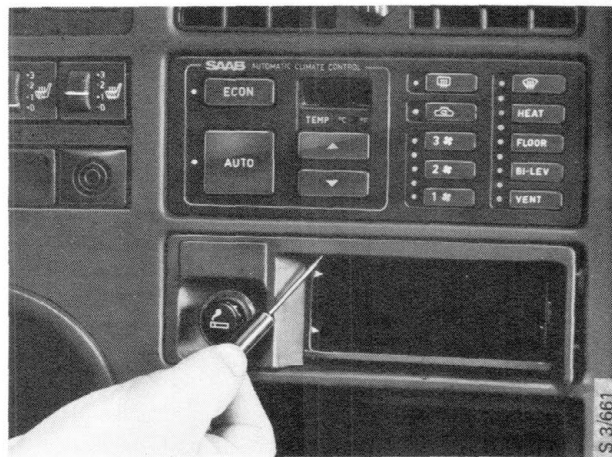

## 381-20 Instruments

3 Press out the ACC panel.

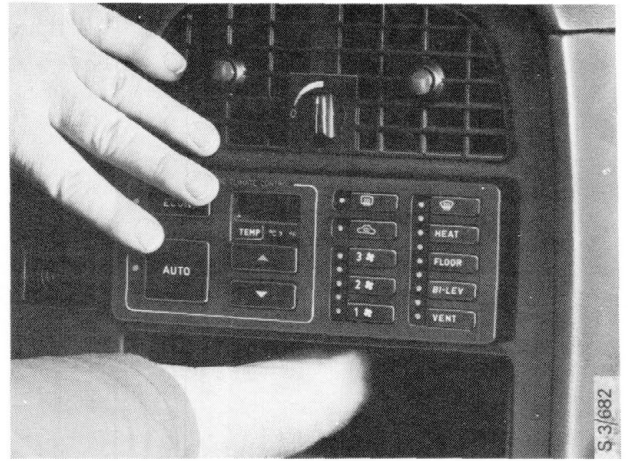

4 Press out the clock/DCC and remove it. Disconnect the connectors.

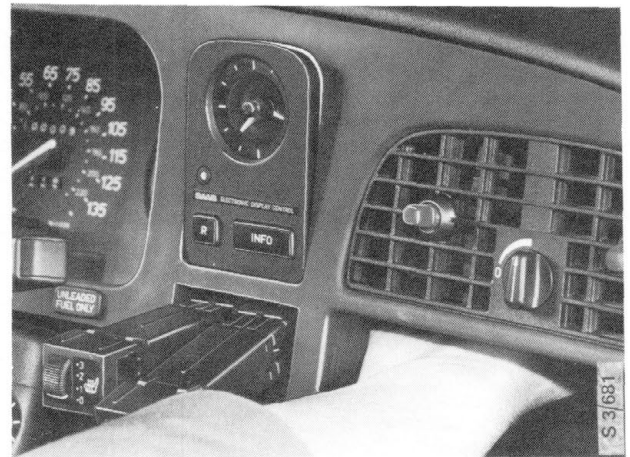

### To fit

Refit in the reverse order.

**To change the bulbs in the combined instrument and clock/DCC**

- 1 Remove the speaker grilles on both sides of the facia.

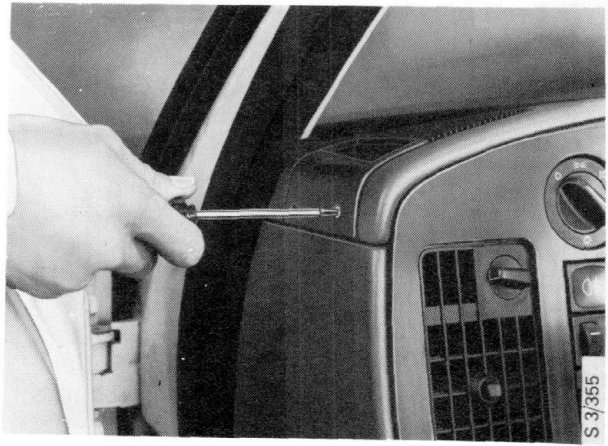

- 2 Remove the seven screws (including one in the glove compartment) securing the top section of the facia.

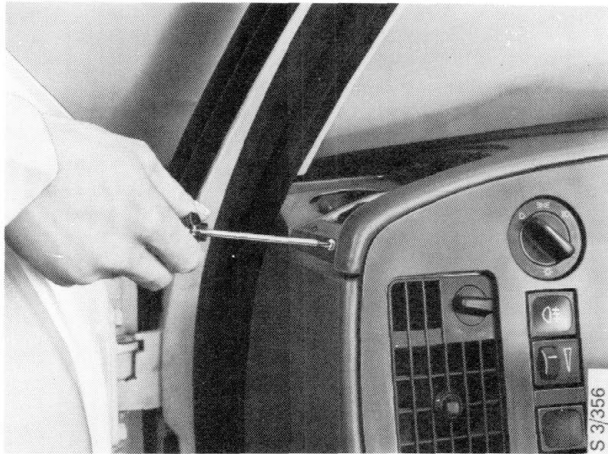

- 3 Lift off the top section of the facia.



- 4 Remove the air duct.



- 5 The bulbs in the combined instrument and clock, and for the fuel level, charging current and direction indicator warning lamps are now accessible for changing.

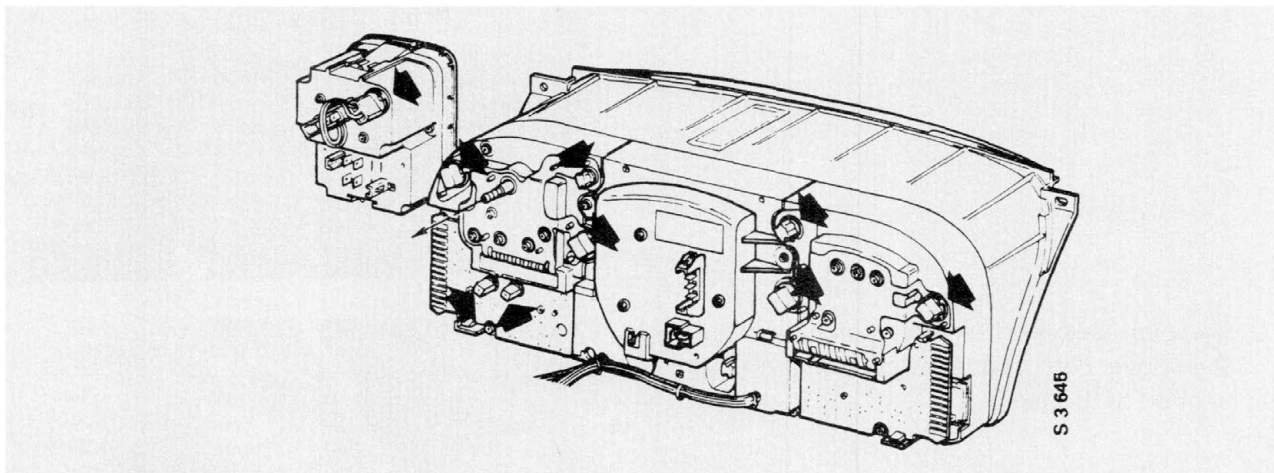

- 6 Remove the two screws and remove the combined instrument.



- 7 The bulbs for the display can now be changed. This is best done by turning the bulbs, and then using a pair of pliers to remove them.

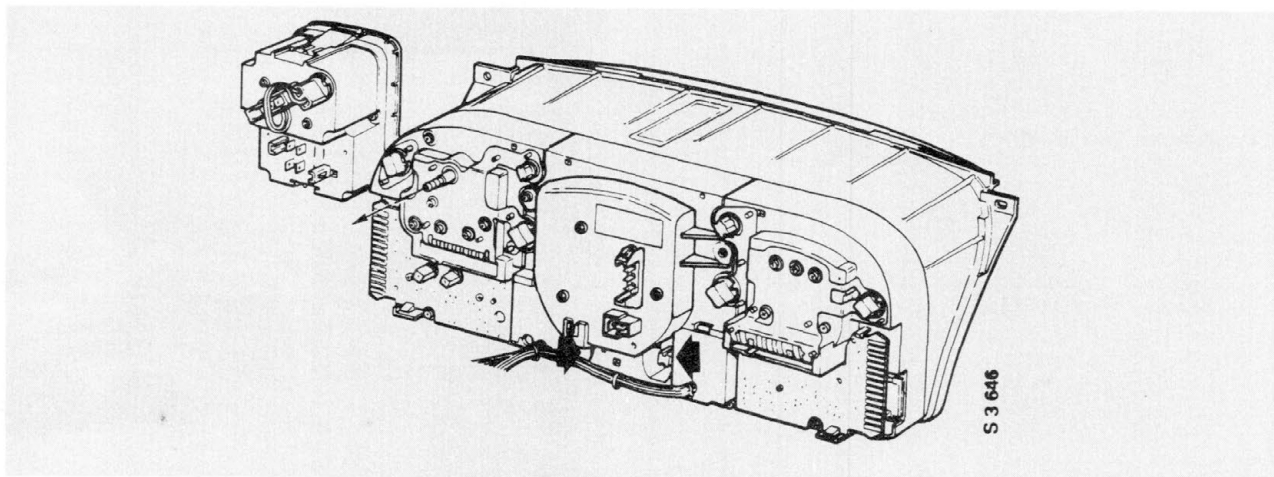

8 To change the bulbs in the pictogram or warning unit, remove the circuit boards by first removing the screws and then bend back the plastic lugs.

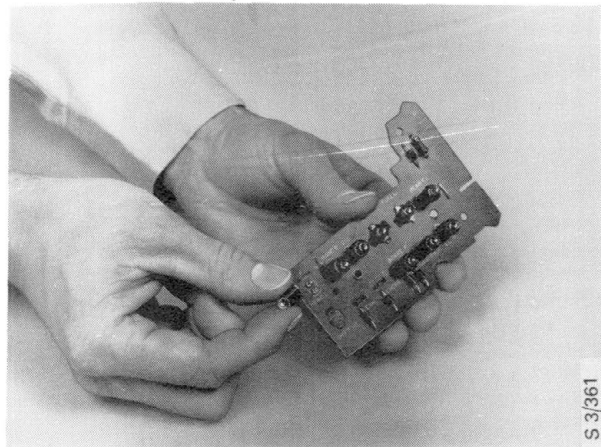
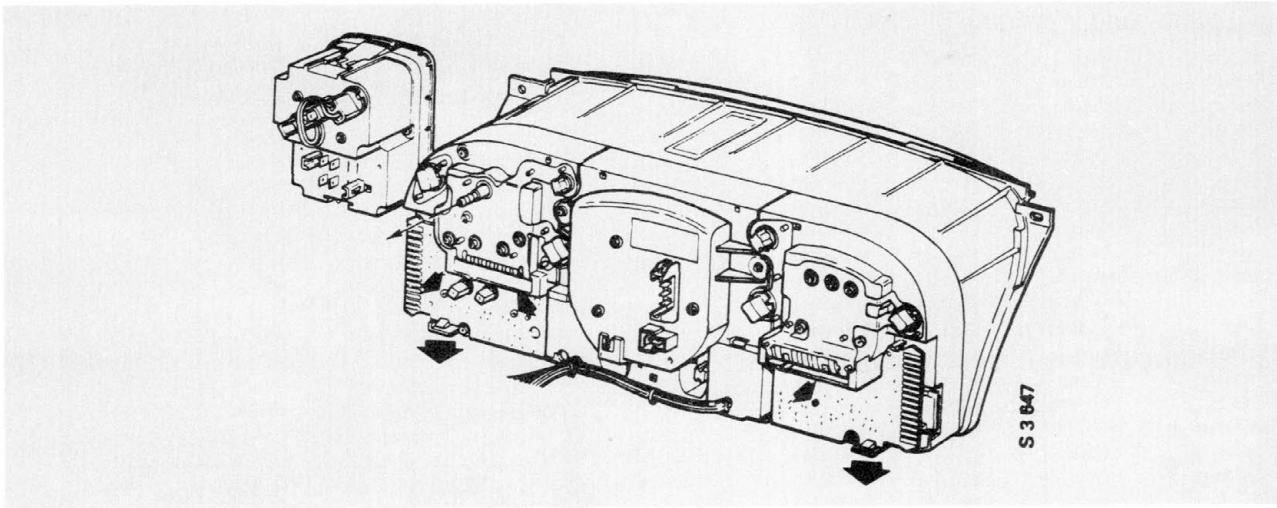

### To dismantle the combined instrument

- 1 Remove the circuit boards with bulb holders for the pictogram and warning lamps.
- 2 Remove the screws securing the electronic display and lift off the display.

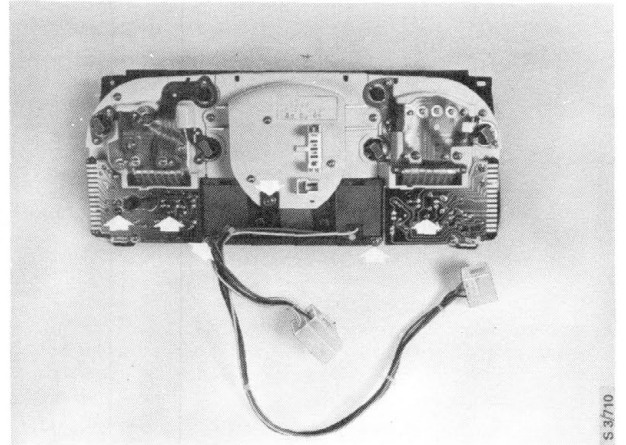

- 3 Remove the instrument retaining screws.

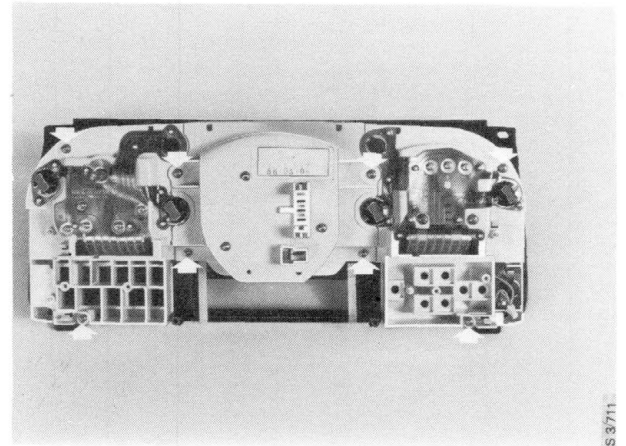

- 4 Remove the speedometer. The other instruments can now be removed.

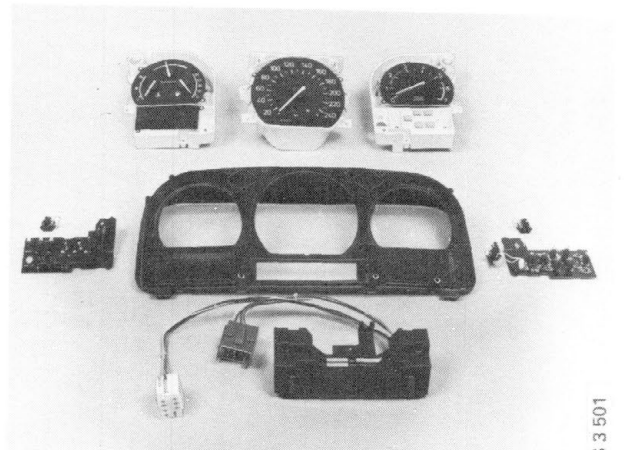
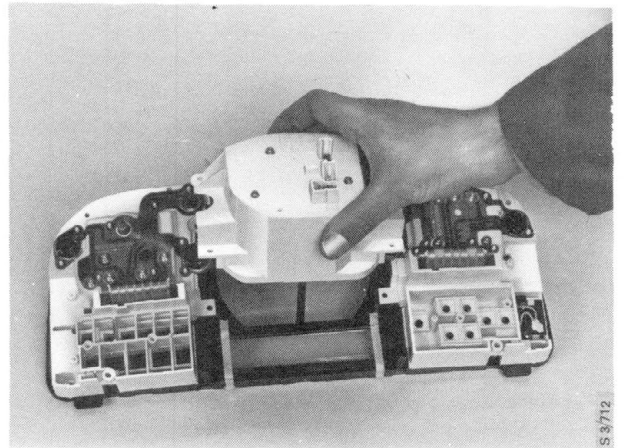



**To assemble**

Assemble in the reverse order.

---

**N.B.**

Do not interchange the screws, since they are of different lengths.

---

Saab-Scania AB  
Saab Car Division  
Nyköping, Sweden

---

 American edition. Ordering No. **334052**. Printed in Sweden by Graphic Systems AB, Göteborg 1986.

