

Saab 900

SERVICE MANUAL

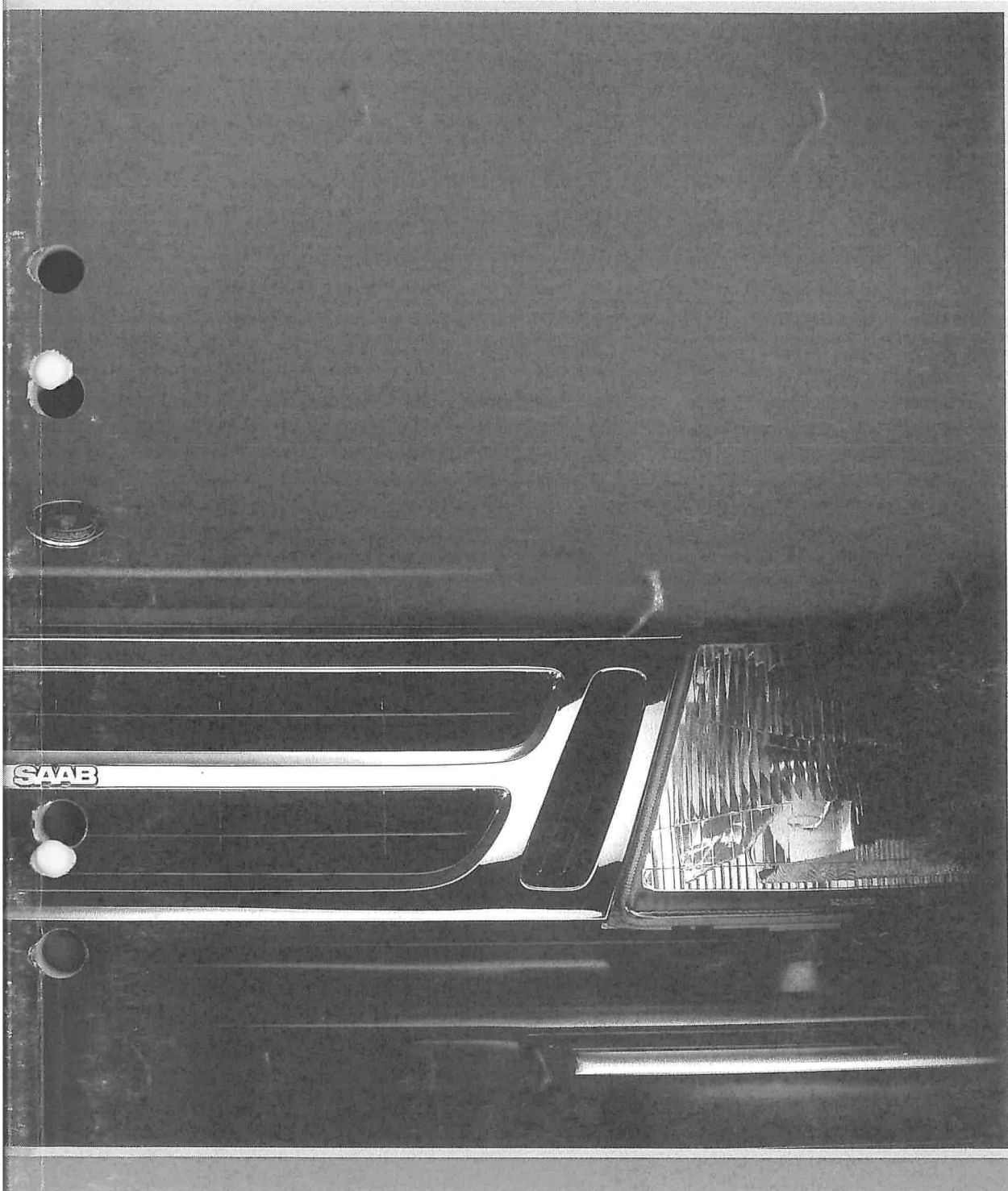

SAAB

4:1 Manual gearbox

M 1989 -



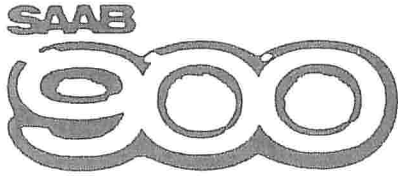

SERVICE MANUAL

4:1 Manual gearbox M 1989-

024 Technical data

104 Special tools

400 Technical description

411 Clutch

412 Clutch control

430 General

431 Removing and refitting

432 Gearbox control

471 Dismantling and assembly

473 Differential

475 Drive shafts

Units

The basic and derived units used throughout the Service Manual are in accordance with the SI system.

For users not familiar with the SI units, some non-Continental units are given in brackets after the respective SI unit.

The following symbols and abbreviations are used:

SI unit	Equivalent unit and symbol
mm	inch (in)
kg	pound (lb)
N	pound-force (lbf)
Nm	pound-force foot (lbf ft)
bar	pound-force per square inch (lbf/in ²) (Also abbreviated: psi)
l (litre)	US liquid quart (liq qt) (Also abbreviated: qts)
°C	US gallon (USgal) °F

Conversion factors

1 in = 25.4 mm	1 mm = 0.039 in
1 lbf = 4.45 N	1 N = 0.23 lbf
1 lbf ft = 1.36 Nm	1 Nm = 0.74 lbf ft
1 psi = 0.07 bar	1 bar = 14.5 lbf/in ²
1 liq qt = 0.95 l	1 l = 1.05 liq qt
1 US liq qt = 0.83 UKqt	1 USgal = 0.83 UKgal

Market codes

The codes refer to market specifications

AT	Austria	FR	France
AU	Australia	GB	Great Britain
BE	Belgium	GR	Greece
CA	Canada	IS	Iceland
CH	Switzerland	IT	Italy
DE	Germany	JP	Japan
DK	Denmark	ME	Middle East
ES	Spain	NL	Netherlands
EU	Europe	NO	Norway
FE	Far East	SE	Sweden
FI	Finland	US	USA

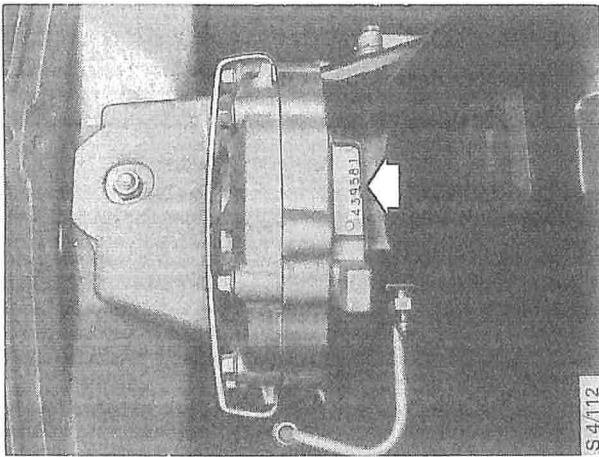

Gearbox serial number

Type designation

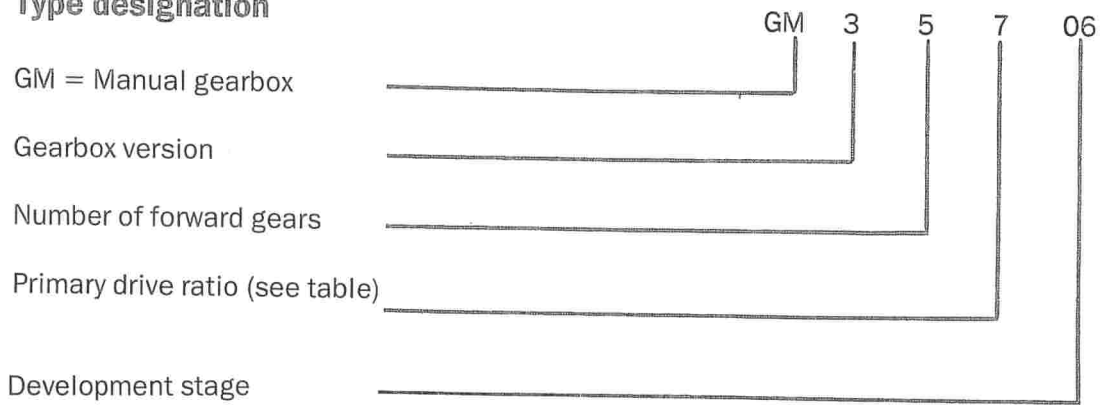

Specifications

Clutch

Make	Fichtel & Sachs	
Type	Single, dry-plate with spring-loaded hub and damper	
Operation	Hydraulic	
Diameter, standard,	in (mm)	8 (204)
Diameter, Turbo,	in (mm)	8.5 (216)

Drive shafts

Universal joints, inner,	80g in driver and 60g in	
grease volume	in gaiter	
grease type, inner	Esso Beacon EP2	
grease type, outer	Esso Nebula EP2, Molykote VN 2463C	

Oil

Oil capacity	approx. 3.0 litres	
Oil type	SAE 10 W 30 or SAE 10 W 40 engine oil or SAE EP 75 API GL 4 or API GL 5	

Bearing preload

Differential bearings:

New, lightly oiled bearings	Nm (lbf ft)	1.8 - 2.8 (1.3 - 2.1)
After more than 2 000 km (1 200 miles)	Nm (lbf ft)	0.8 - 1.3 (0.59 - 0.95)

Pinion bearing

New, lightly oiled bearings	Nm (lbf ft)	2.5 ± 0.5 (1.8 ± 0.4)
After more than 2 000 km (1 200 miles)	Nm (lbf ft)	1.3 ± 0.5 (1.0 ± 0.4)

Tightening torques

All 8 mm dia. bolts	Nm (lbf ft)	23 - 28 (17 - 21)
Gearcase drain plugs	Nm (lbf ft)	39 - 59 (28 - 44)
Engine	Nm (lbf ft)	29 - 39 (22 - 29)
Slave cylinder mounting bolts	Nm (lbf ft)	6 - 14 (4.4 - 10.0)
M8 crown wheel bolts	Nm (lbf ft)	50 ± 5 (37 ± 4.0)
M10 x 1.25 crown wheel bolts	Nm (lbf ft)	90 ± 10 (66 ± 7)
Output shaft nut in clutchhub	Nm (lbf ft)	50 ± 10 (37 ± 7)
Input shaft nut	Nm (lbf ft)	100 ± 10 (74 ± 7.4)
Pinion bearing housing	Nm (lbf ft)	23 - 28 (17 - 21)

Year	Model	Gearbox designation	Tyres	Dynamic rolling radius mento	Primary drive ratio	Intermediate drive	Final drive ratio	Overall ratio										Road speed, km/h, per 1000 rpm				
								1	2	3	4	5	Reverse	1	2	3	4	5				
1989	900i cat.	GM 45612	185/65 R15T	301	31:26 0,84	14:34 2,43	9:35 3,89	14,85	8,64	5,66	4,09	3,26	16,34	7,6	13,1	20,1	27,8	34,8				
	900c, i i16, S16 T8, T16 cat.	GM 45712	175/70 R15T 185/65 R15T	305	35:25 0,78	14:34 2,43	9:35 3,89	13,84	8,05	5,27	3,81	3,04	15,22	8,3	14,3	21,8	30,2	37,8				
	900T8 T16 cat. T16S T16	GM 55704	195/60 R15HVR	299	35:25 0,78	14:34 2,43	9:35 3,89	13,84	8,05	5,27	3,81	3,04	15,22	8,1	14,0	21,4	29,6	37,1				

Drain plugs

The gearcase is provided with a filler tube and dipstick, and a drain plug for the oil in the gearcase, with a 12 mm socket head.

When the gearcase is filled with the specified quantity of oil, the level on the dipstick will be between the MIN and MAX marks.

When filling an empty gearbox (after overhaul), fill the primary chaincase with 0.7 litres of oil and the gearcase with 2.7 litres.

Top up with oil when the level has dropped to the minimum mark or below. Overfilling will cause stiff gear-changing when the gearbox is cold.

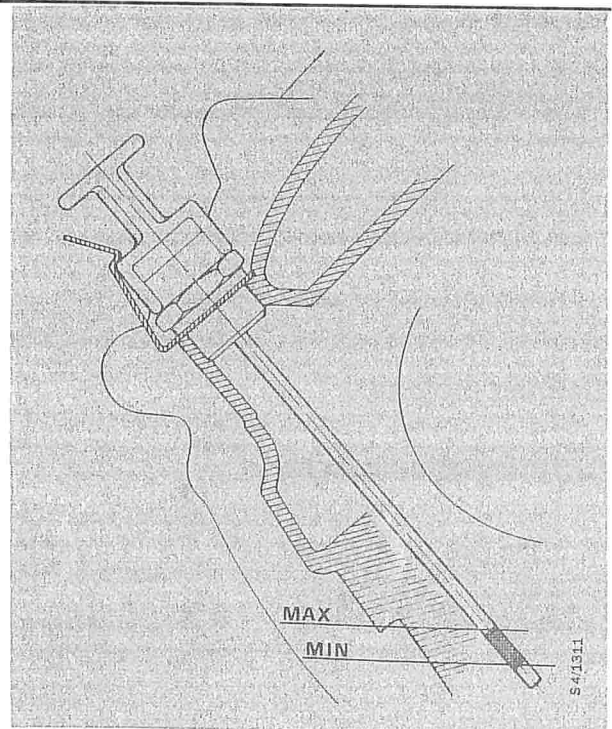

Summary of lubricants

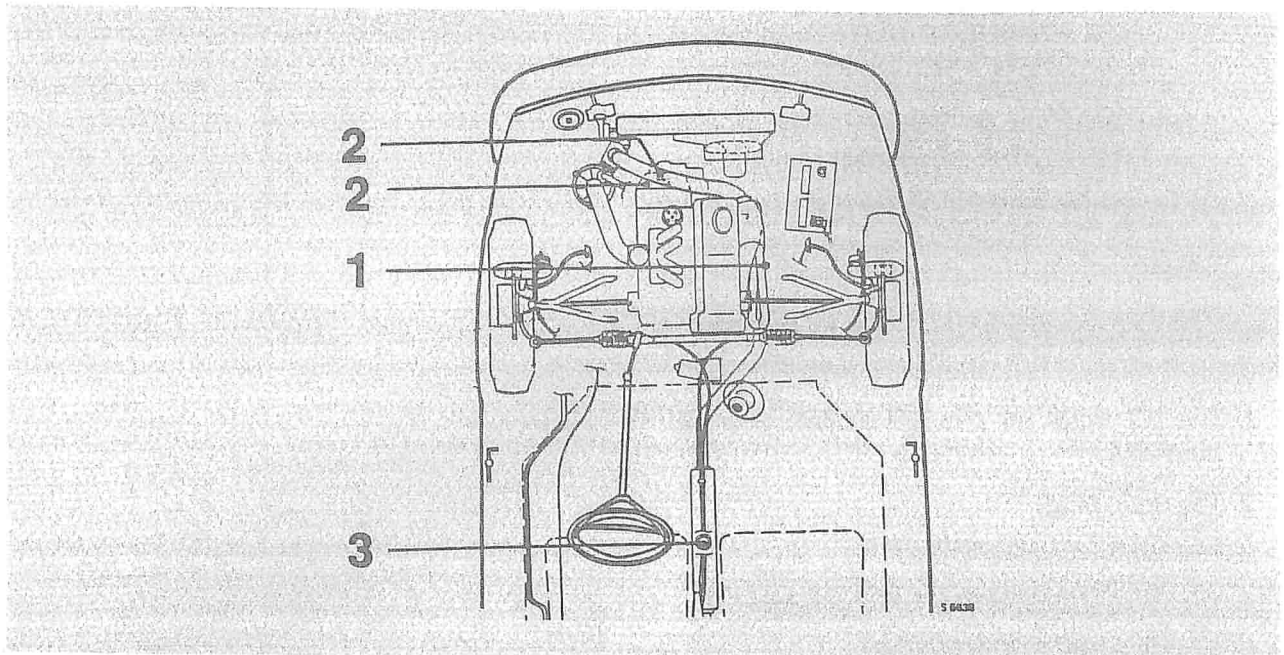

	Lubrication point	Lubricant
1	Gearbox	SAE 10 W 30 or 10 W 40 engine oil or SAE EP 75 API-GL 4 or API-GL 5
2	Clutch release bearing	Permanently lubricated at the factory. Do not wash.
	Clutch shaft splines	Molybdenum disulphide paste when fitting, or Saab Special chassis grease
	Clutch support bearing in flywheel	Permanently lubricated at the factory. Do not wash.
3	Gear lever housing	Soft EPI grease

Summary of lubricants

Esso Nebula EP2 grease (Saab Special chassis grease) should be used for the following lubrication points:

- 1 Space between the lips of the inner universal joint seals and the clutch shaft seal.
- 2 Clutch shaft splines and shaft end at the flywheel before fitting (very sparingly).

Apply Loctite 510 (45) 3020 468 to the face between the primary drive chaincase and the gearcase.

Use thread sealing compound (Loctite, part No. (45) 3009081) at the following points:

- 1 The 12 bolts for the differential bearing housings.
- 2 The drain plug.
- 3 The chain tensioner bolts.
- 4 The three bolts at the bearing support.
- 5 The slave cylinder bolts.
- 6 The three gearcase cover bolts.

N.B. Make sure that the surfaces to which sealing compound is applied are dry.

Apply locking fluid (Loctite 242, part No. (45) 3007200) to the following points:

- 1 Stop screw for the reverse gear shaft.
- 2 Reverse gear selector screw.
- 3 Bolt for the locking plate for reverse gear and layshaft.
- 4 The four bolts in the pinion bearing housing.
- 5 The 12 crown wheel bolts.

Apply locking fluid (Loctite 270, part No. (45) 3007218) to the pinion nut threads.

Oil sparingly the following slave cylinder parts with Castrol UBCF 11 oil:

Inside and outside cylinder diameters, cylinder housing, lip seal and inside diameter, and end face against the lip seal.

Special tools

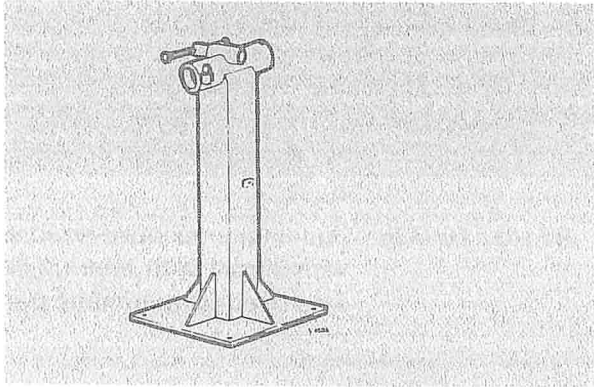

78 60 794 (A1) Floor stand for permanent mounting

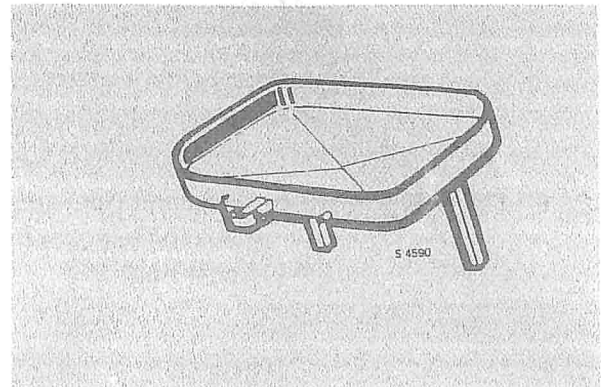

78 60 802 (A2) Oil pan

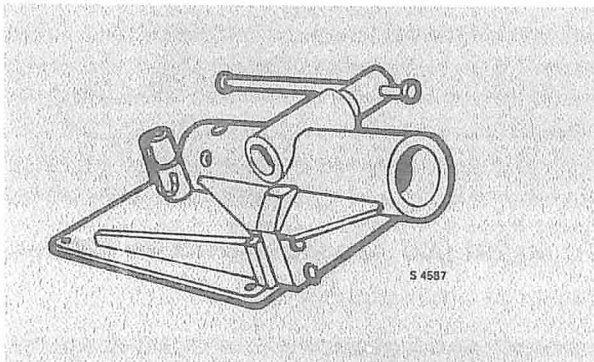

78 60 877 Bench stand, movable (alt. to 78 60 794)

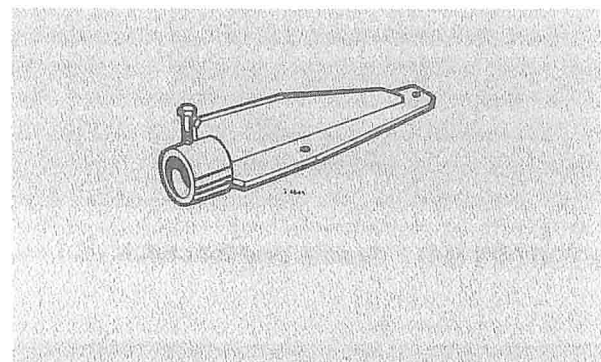

83 90 460 (A2) Gearcase support bracket

78 60 885 Vice stand

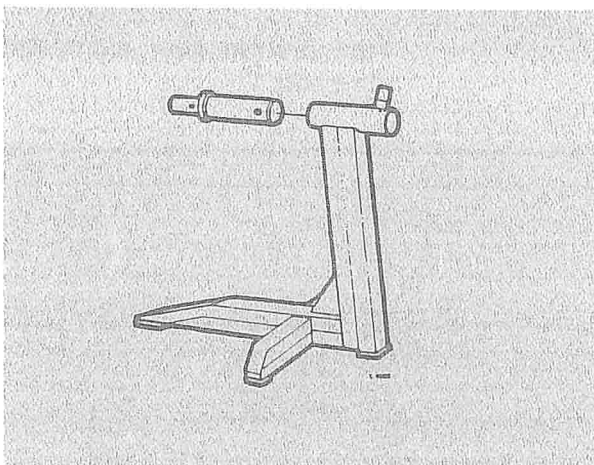

78 61 479 (A2) Stand

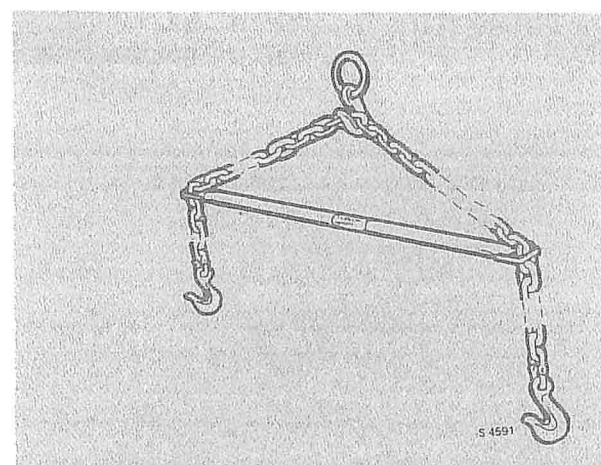

83 92 409 (A1) Lifting yoke

83 90 478 (A2) Spindle for stand

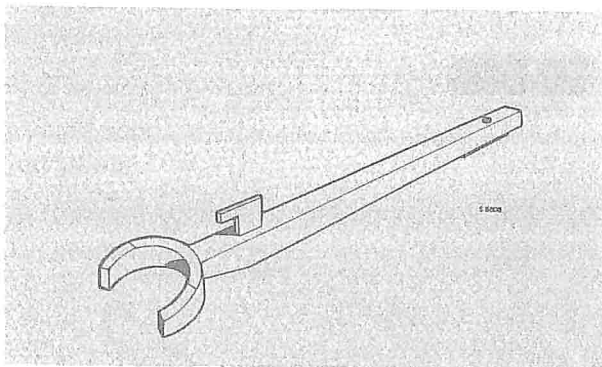

83 93 175 (A1) Lever for removing the clutch shaft (can also be used for fitting the spacer ring)

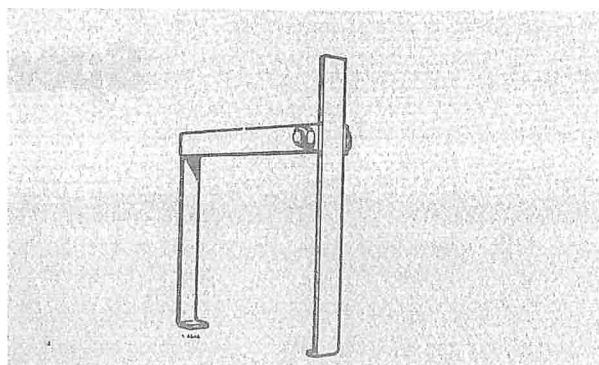

87 90 776 (A1) Puller for inner drive-shaft universal joint with bearing cap. Also used for automatic transmission.

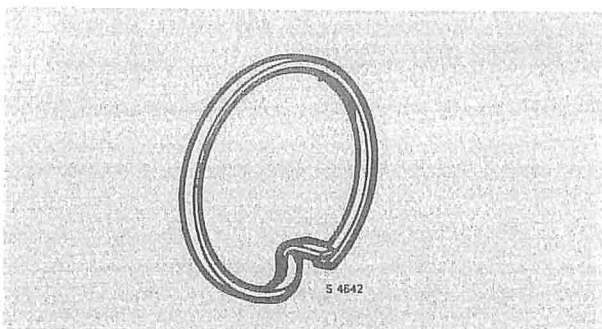

83 90 023 (A1) Spacer ring for clutch

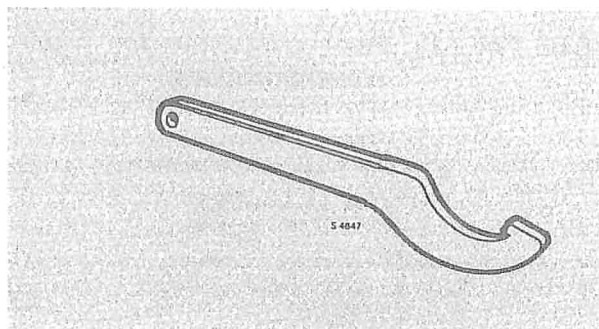

87 90 197 (A2) Hook wrench for layshaft

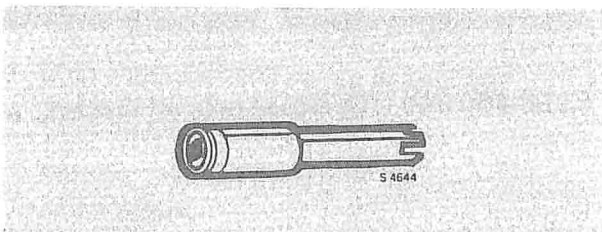

87 90 370 (A1) Spanner for special nut for gear lever housing. Also automatic transmission.

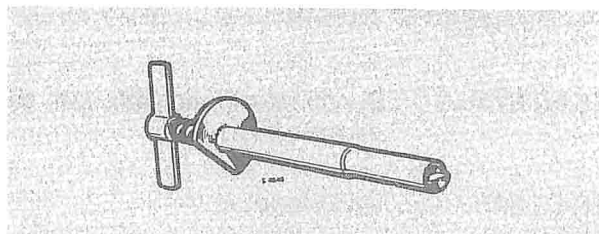

83 90 049 (A2) Puller for fitting and removing the reverse gear shaft and layshaft

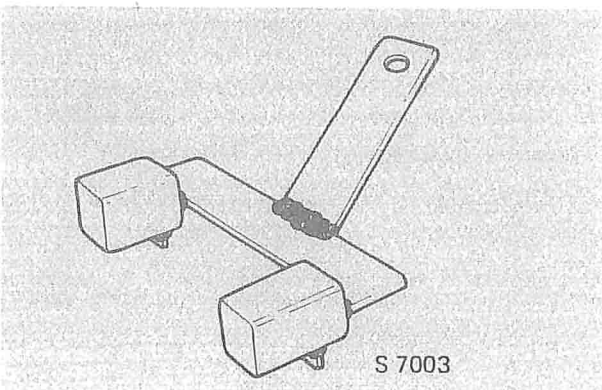

83 93 209 (A1) Spacer tool for relieving the load of the suspension spring assembly when lifting out the power unit (see also Group 2)

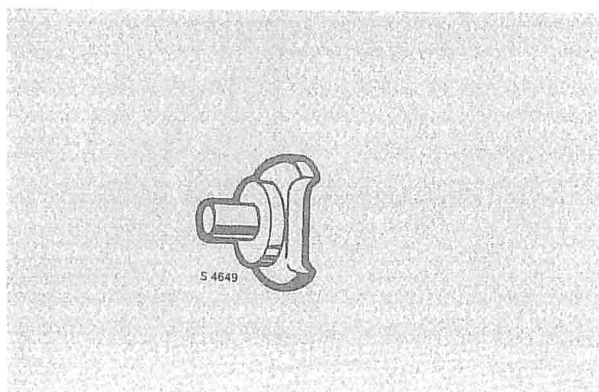

87 90 503 (A2) Locking tool for reverse gear-wheel

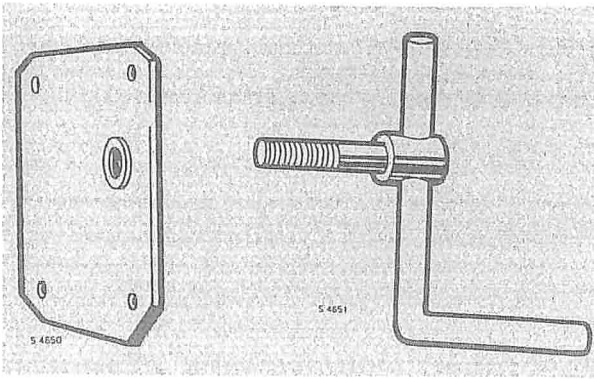

87 90 511 (A2) Puller for output shaft
78 40 853 Screw (for output shaft puller)

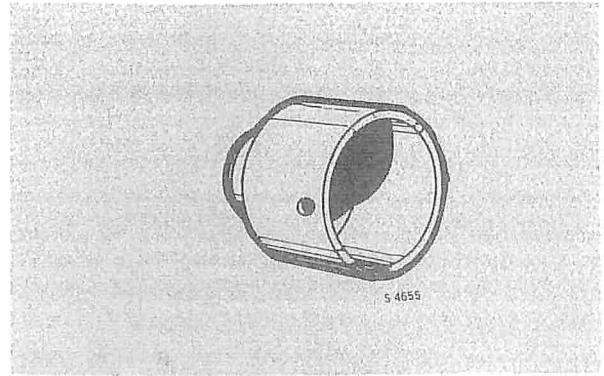

83 90 114 (A2) Sleeve for fitting of 4th gear, bearing housing outer race, pinion and pinion shaft unit.

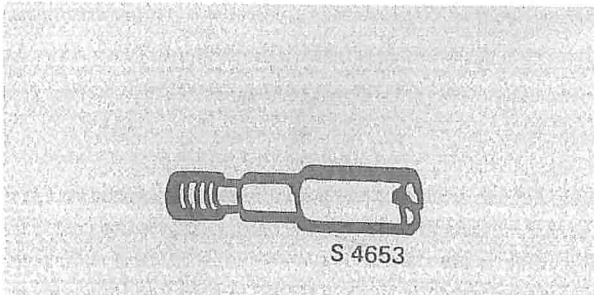

87 90 438 (A2) Guide pin for pinion bearing housing and input shaft bearing housing (two needed). Also for automatic transmission

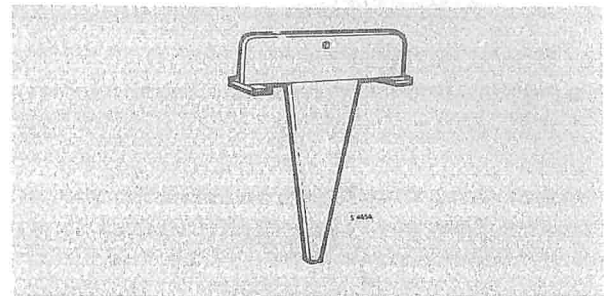

87 90 552 (A2) Gauge for output shaft position in relation to the gear case.

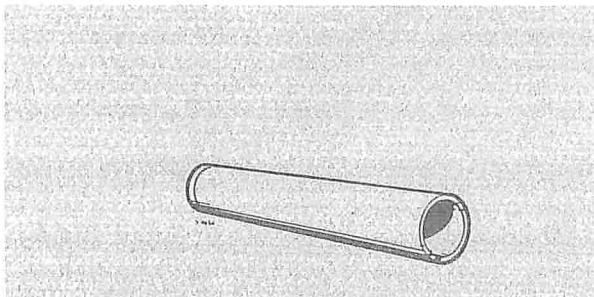

83 90 148 (A2) Sleeve for fitting of output shaft unit, inner roller bearing, pinion, primary chaincase roller bearing inner race and layshaft outer bearing. For removing of primary drive roller bearing, bearing housing outer races, layshaft inner race and clutch shaft seal.

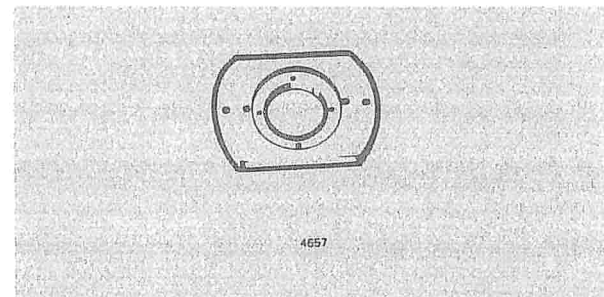

87 90 636 (A2) Fixture for removing and fitting the pinion bearing

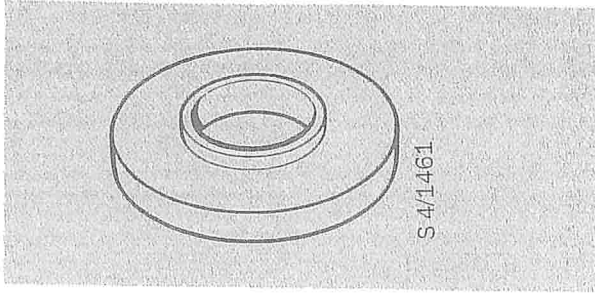

87 91 972 (A2) Fitting ring (used together with tool 87 90 636). For fitting the output shaft (5-speed).

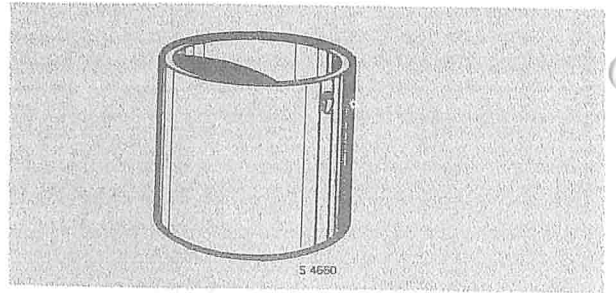

83 90 098 (A2) Dolly for fitting and removing the roller bearing housing outer races and output shaft

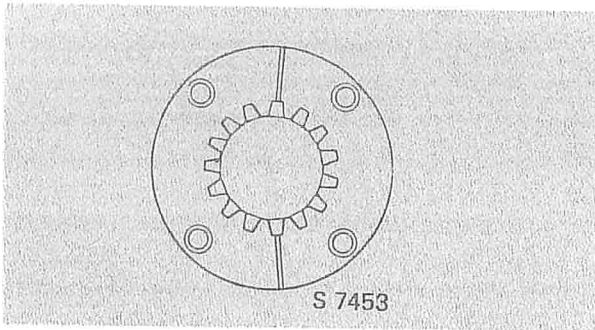

87 90 933 (A2) Puller ring (used with tool 87 90 636). For removing input shaft roller bearing.

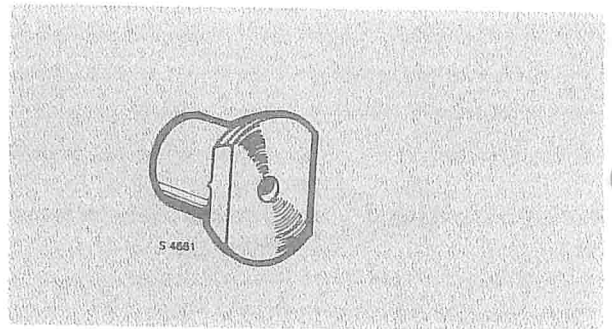

83 90 106 (A2) Drift for removing the pinion roller bearing outer race

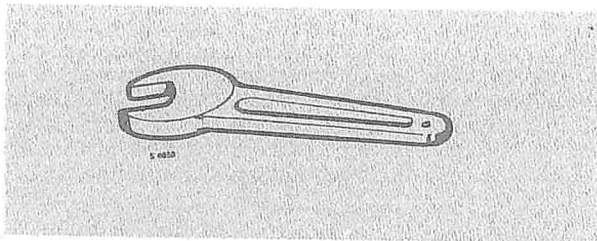

87 90 453 (A2) Spanner for output shaft nut.

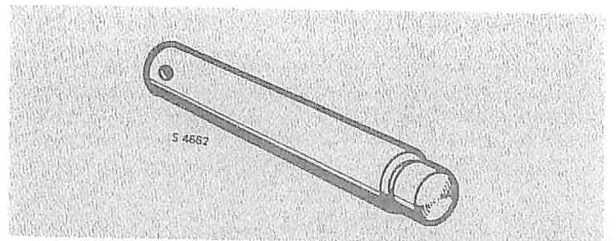

83 90 189 (A2) Drift for fitting input pinion with ball bearing, and removing outer races from bearing seats, outer race and seal from steering knuckle housing. Also for automatic transmission.

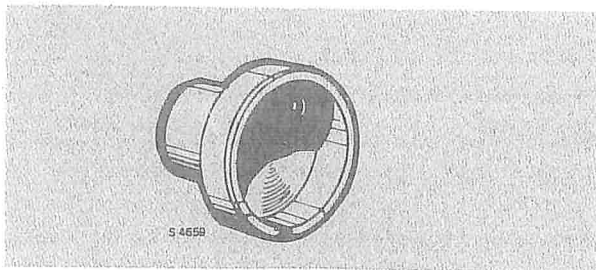

83 90 122 (A2) Drift for fitting the bearing housing outer race (pinion) and ball bearing on 4th gear, and removing primary sprocket with bearing from bearing housing.



87 90 461 (A2) Sleeve for bearing race in pinion bearing housing. Also used for automatic transmission.

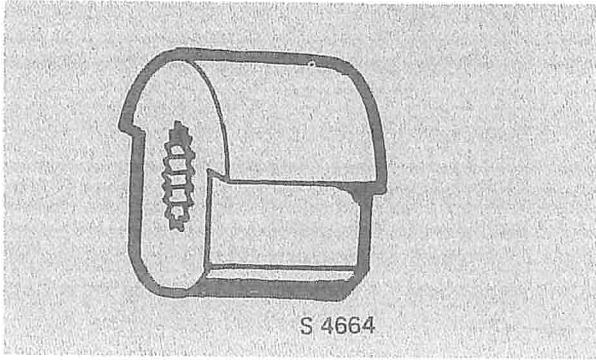

83 90 446 Holder for output shaft

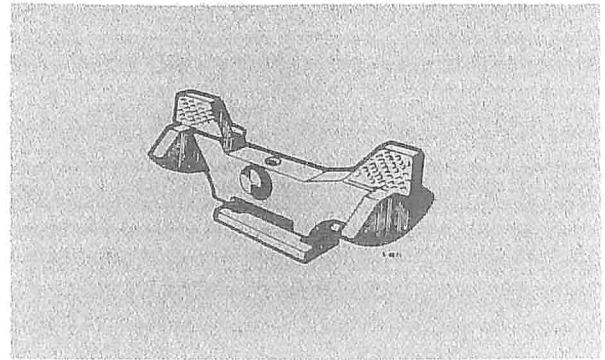

83 90 155 (A2) Measuring jig for pinion position.

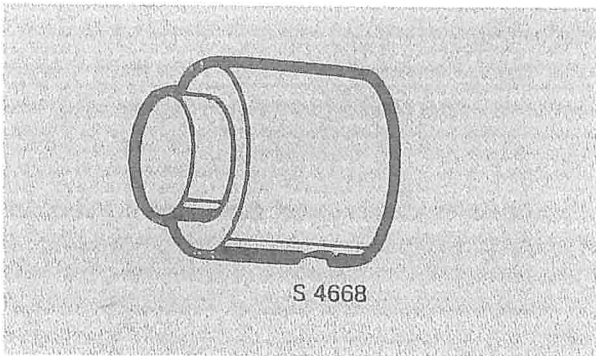

87 90 487 (A2) Sleeve for differential housing bearing. Also for automatic transmission.

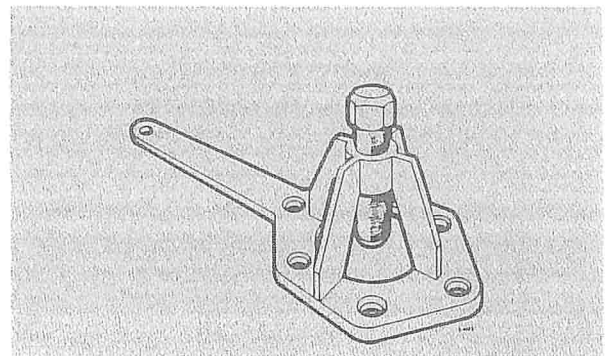

89 96 084 (A1) Puller for removing the front and rear axle hubs, differential housing bearing race, and engine chain sprocket.

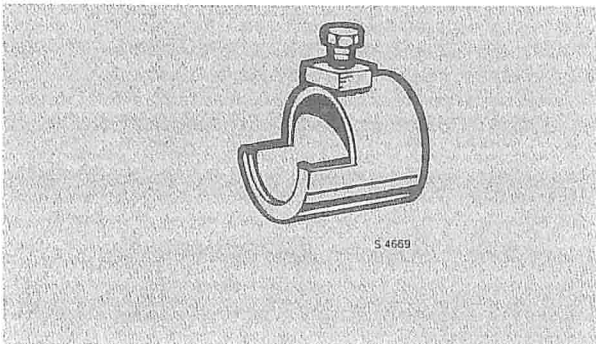

87 90 677 (A2) Tool for removing the selector rod seal.

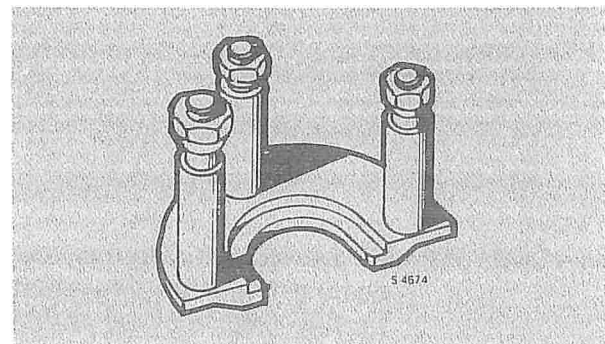

87 90 768 (A2) Puller for removing the bearing races from the differential housing and gearcase

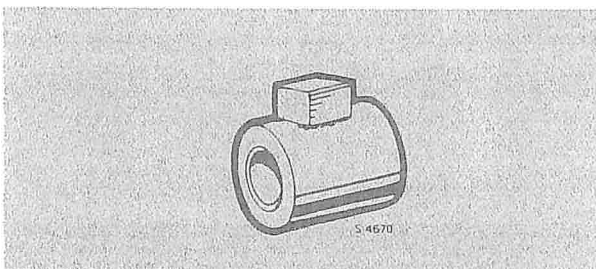

87 90 685 (A1) Tool for fitting the selector rod seal.

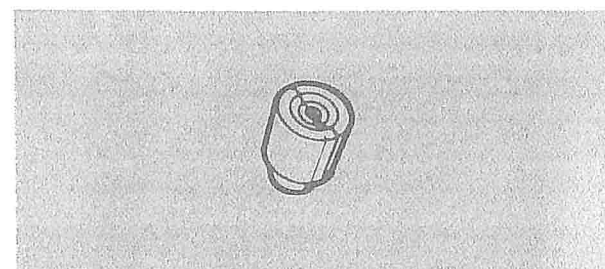

89 95 177 (A2) Dolly for removing the bearing race from the differential housing

104-6 Special tools

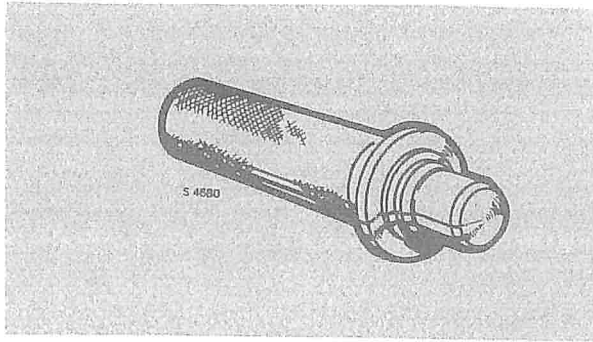

87 90 800 (A2) Drift for pressing the seal into the differential bearing housing

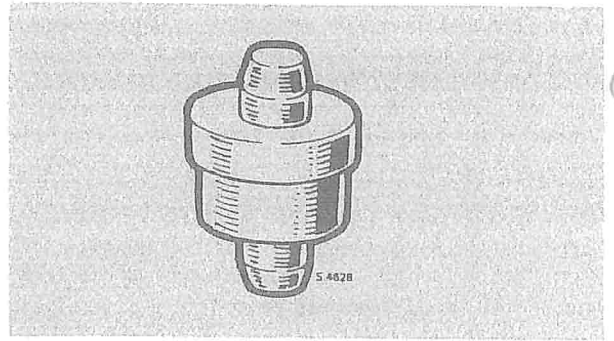

83 91 997 (A2) Drift for clutch shaft seal and needle bearing in primary chaincase.

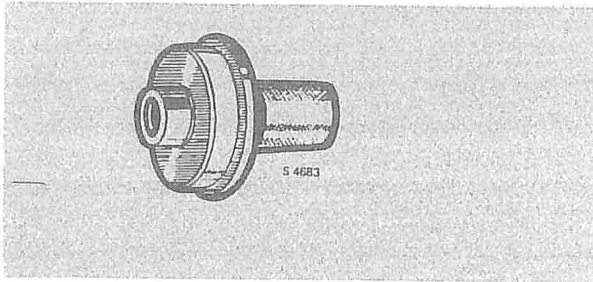

78 41 141 (A2) Sleeve for pressing in the ball bearing into the differential bearing housing.

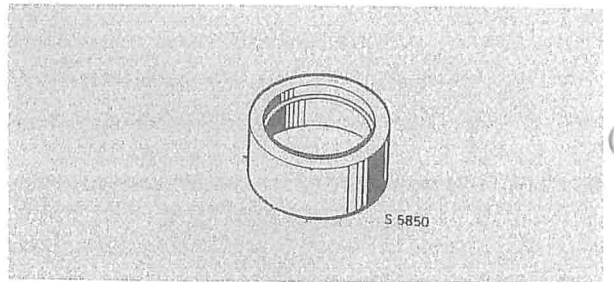

87 90 867 (A2) Ring for fitting the roller bearing onto the gearbox input shaft.

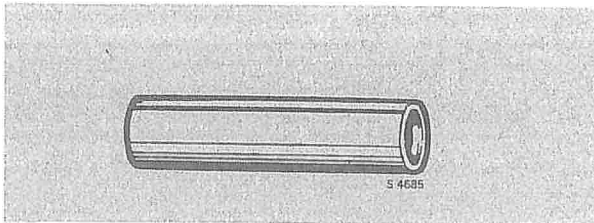

78 41 067 (A2) Sleeve for removing the ball bearing from the differential bearing housing and fitting the ball bearing onto the inner driver.

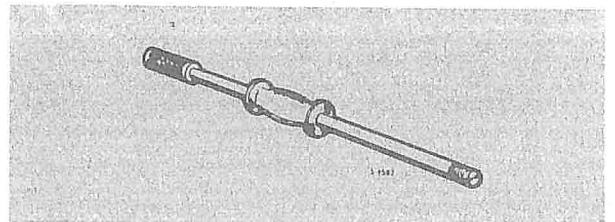

83 90 270 (A2) Sliding hammer.

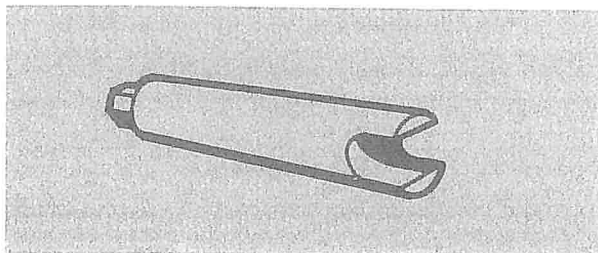

87 90 818 (A2) Driver for measuring the differential bearing rolling resistance.

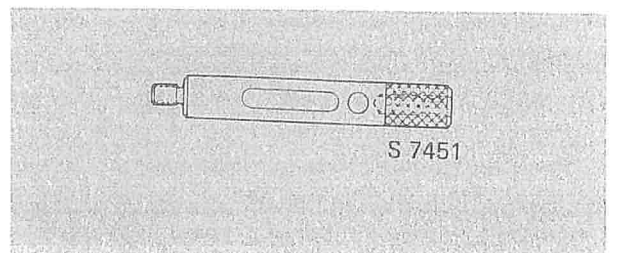

87 90 909 (A2) Spacer bolts (4 for tool 87 90 511). For pressing out the output shaft.

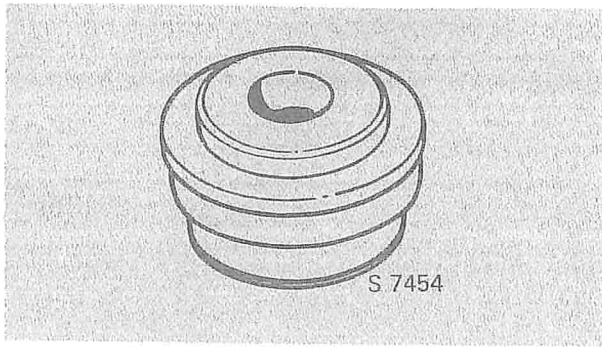

83 90 312 (A2) Drift for pressing the bearing races onto the input shaft.

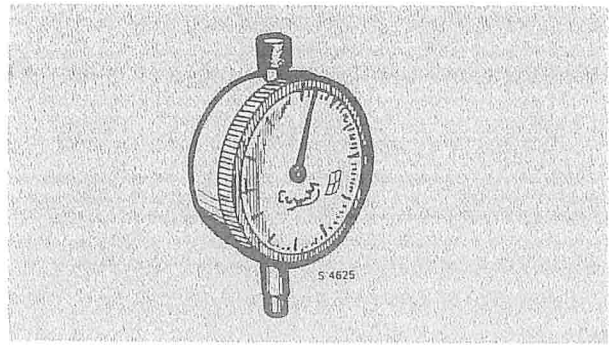

78 40 622 Dial indicator.

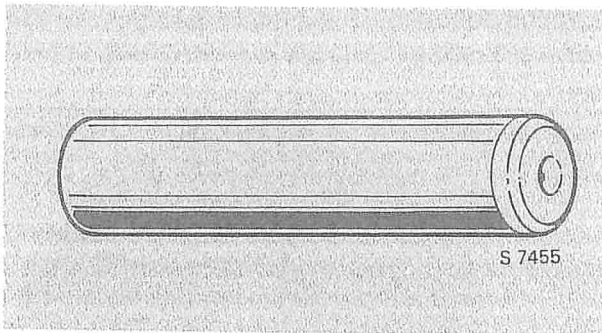

78 41 075 (A2) Sleeve for fitting the input shaft roller bearing.

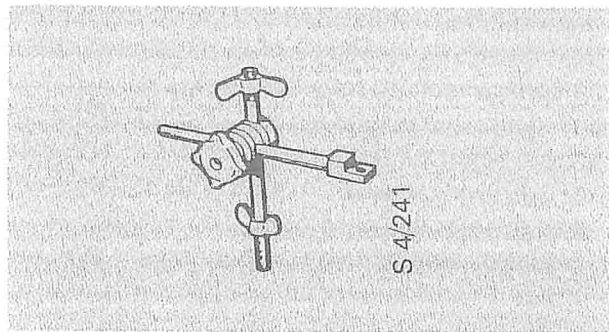

87 90 727 Holder for dial indicator. For measuring the backlash in the final drive.

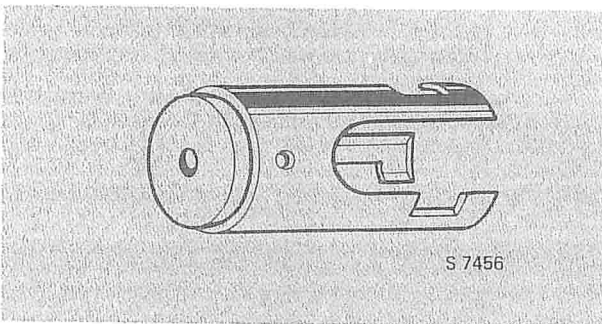

87 90 891 (A2) Puller sleeve for primary drive sprocket. Used together with sliding hammer 83 90 270

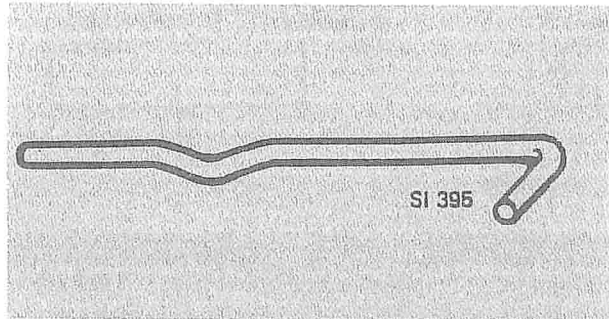

87 91 576 Locating tool for presetting the gear positions.

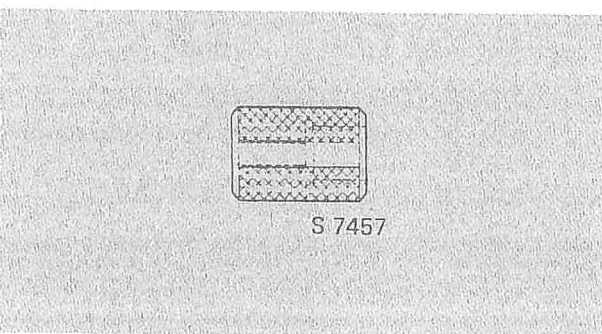

87 90 917 (A2) Adapter (for sliding hammer). For removing/fitting the input shaft.

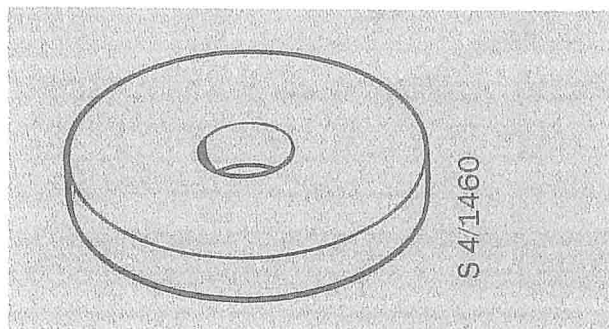

87 91 964 Ring for fitting the rear pinion bearing race.



Clutch

General

The single dry-plate clutch is of diaphragm spring type. The main components of the clutch are the clutch plate, pressure plate unit and release bearing.

The clutch plate consists of a spring-loaded steel plate secured to a hub which slides on splines on the clutch shaft. The hub is equipped with a damper mechanism. One friction lining is riveted to each side of the clutch plate. The pres-

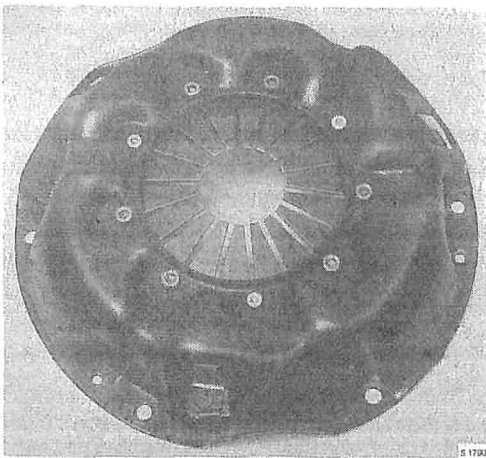

Pressure plate unit

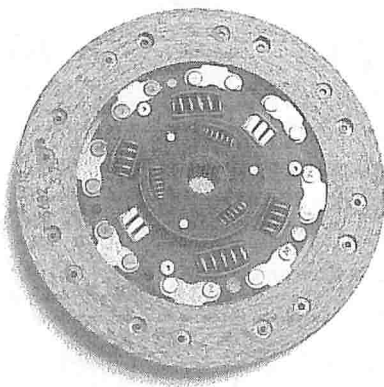

Clutch plate

Clutch operation

- 1 Pressure plate
- 2 Housing
- 3 Diaphragm spring
- 4 Pivot rings
- 5 Release bearing
- 6 Slave cylinder
- 7 Master cylinder
- 8 Clutch pedal
- 9 Clutch fluid reservoir

sure plate unit consists of the pressure plate, diaphragm-type spring and a sheet steel housing. The diaphragm spring serves as a lever and as a spring. The pressure plate unit must not be dismantled.

The release bearing is a ball bearing with a special outer race which presses directly against the diaphragm spring when the clutch pedal is operated. The clutch is hydraulically operated. The clutch pedal acts on a master cylinder connected hydraulically to a slave cylinder at the clutch. The slave cylinder is annular, and is arranged around the clutch shaft, inside the flywheel housing. The slave cylinder acts directly on the release bearing, and adjustment of the clutch is automatic.

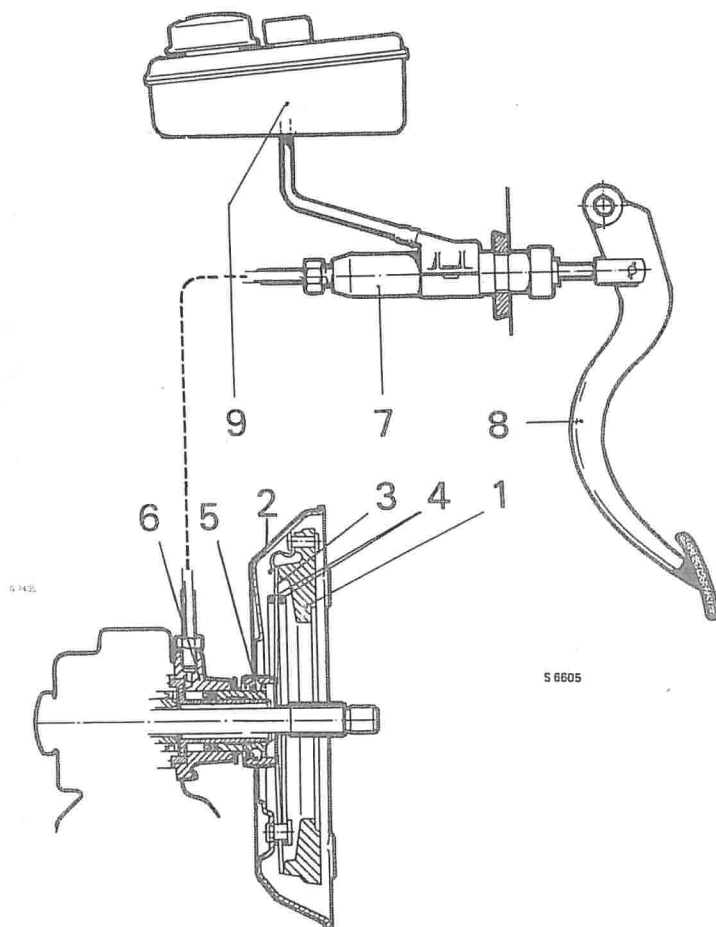

Dismantling for changing the clutch on the 900i 8 with air conditioner

The work should be carried out as described for the 900i 16, except that the left-hand radiator fan must be removed to enable the clutch shaft to be withdrawn.

Dismantling for changing the clutch on the 900i 16

- 1 Remove the bonnet. Get an assistant to help on the other side of the car.
- 2 Remove the rubber bellows from the air cleaner and remove the throttle housing, and place them to one side. The wiring need not be disconnected. Push a piece of cloth into the throttle housing opening to keep out dirt.
- 3 Remove any plastic straps and remove the flywheel housing cover bolts. Remove the bracket for the battery positive cable at the top of the primary chaincase, and tilt out the left-hand side of the flywheel housing cover first.

Lift out the flywheel housing cover.

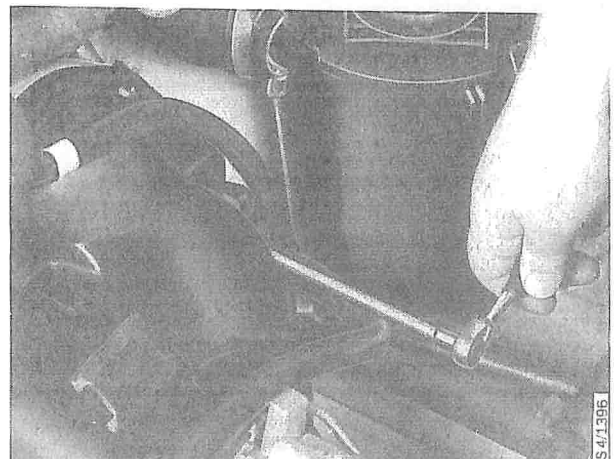
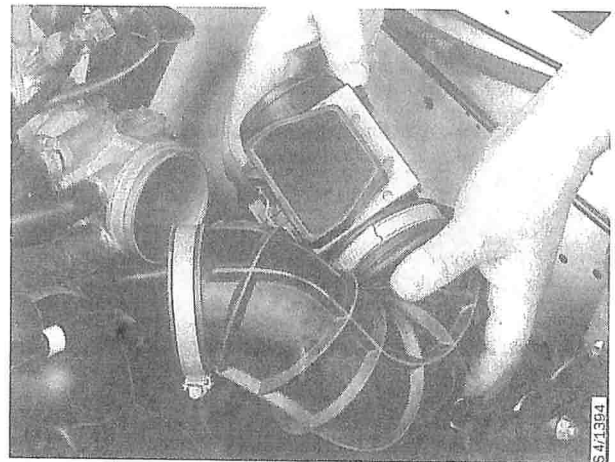

- 4 Get an assistant to press down the clutch pedal. Fit spacer 83 90 023. Use tool 83 94 033 to press in the diaphragm spring.

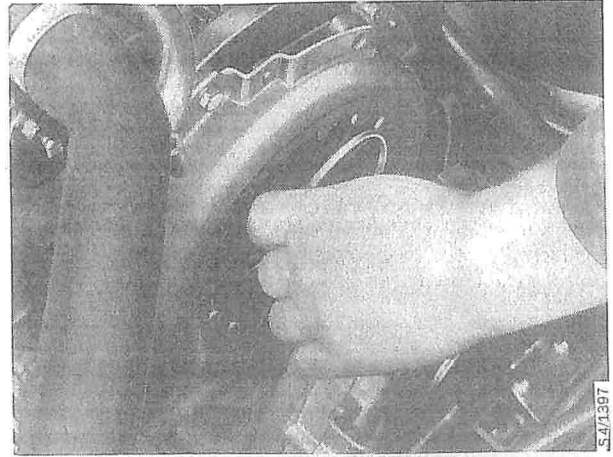

- 5 Remove the clip and cover in front of the clutch shaft.

- 6 Remove the plastic propeller.

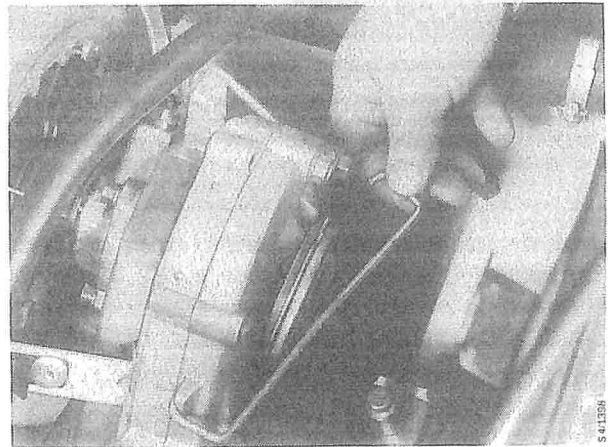

- 7 Screw an 8 mm bolt into the end of the clutch shaft and use tool 83 94 033 to withdraw the shaft. After withdrawing it, leave the shaft where it is.

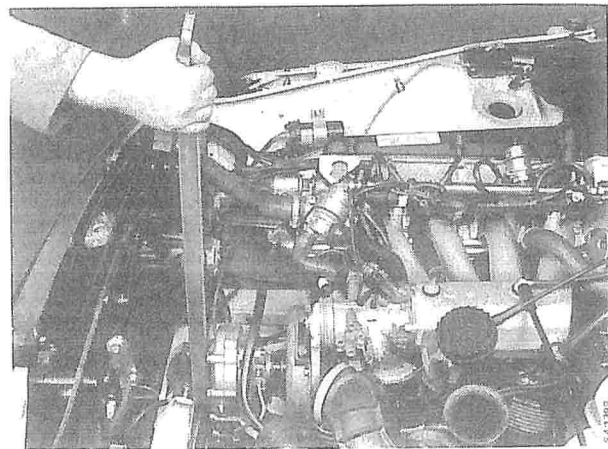

- 8 Remove the three slave cylinder bolts.

Caution

Take care not to damage the slave cylinder sleeve during removal.

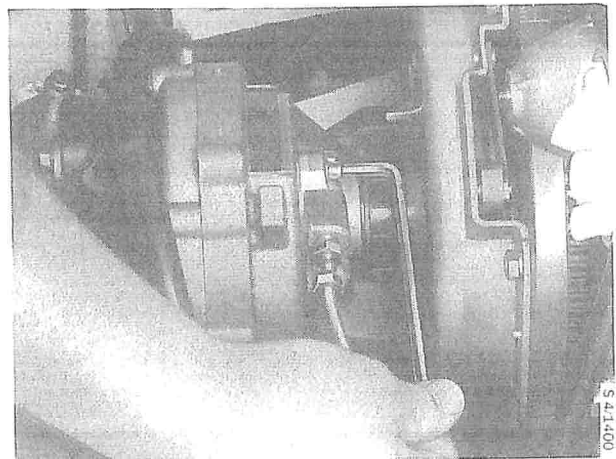

411-4 Clutch

- 9 Remove the pressure plate bolts and move the pressure plate to one side, together with the slave cylinder.

To fit

Before re-assembling the clutch, check the condition of the clutch shaft seal located in the primary drive chaincase, and the condition of the support bearing in the flywheel.

Note

Lubricate the clutch shaft splines sparingly with molybdenum disulphide paste or Saab Special chassis grease.

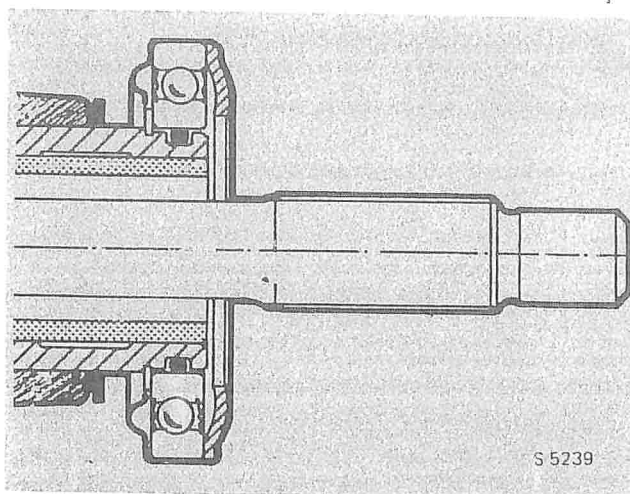
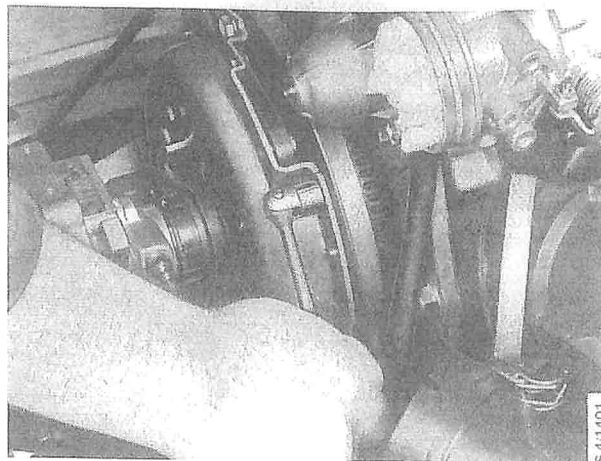

The hardened side of the release bearing must face towards the clutch.

- 1 Fit the pressure plate unit, clutch plate and slave cylinder with release bearing together into the flywheel housing.

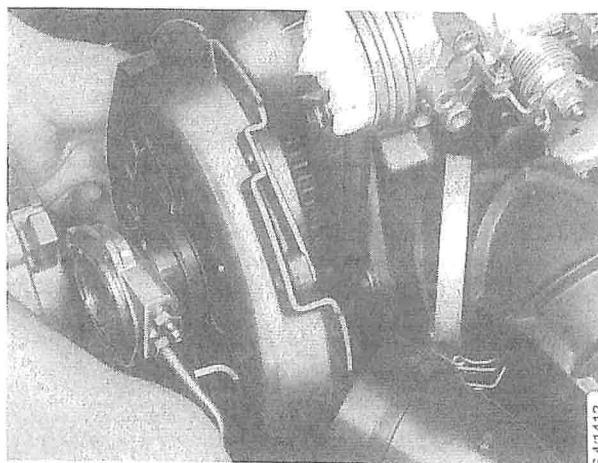

Fit two of the pressure plate bolts but do not tighten them.

Push the clutch shaft into engagement with the clutch plate splines and into the support bearing in the flywheel.

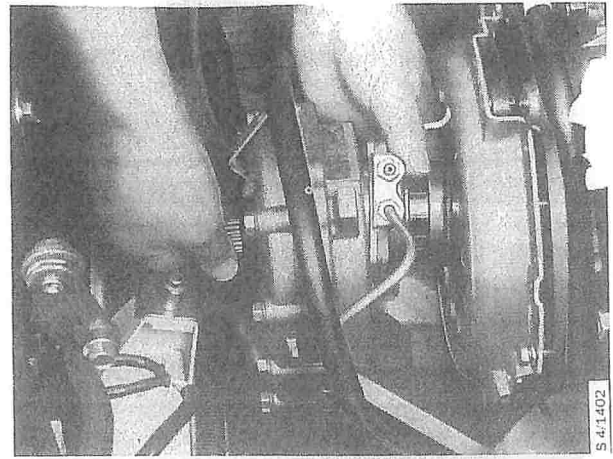

- 2 Finally, tap in the clutch shaft so that it is locked by the snap ring in the primary drive sprocket.

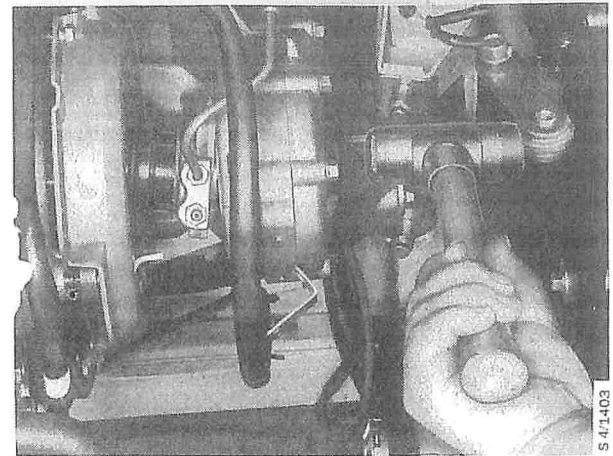

- 3 Apply thread sealing compound to the bolts. Bolt the slave cylinder to the primary chain-case.

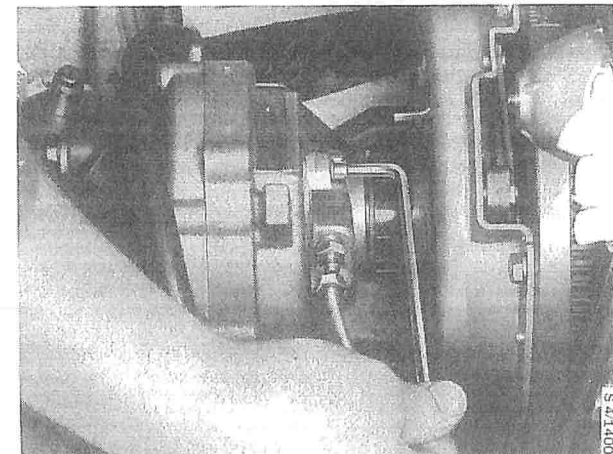

- 4 Fit the plastic propeller to the end of the clutch shaft.
- 5 Fit the seal, cover and clip in front of the clutch shaft.

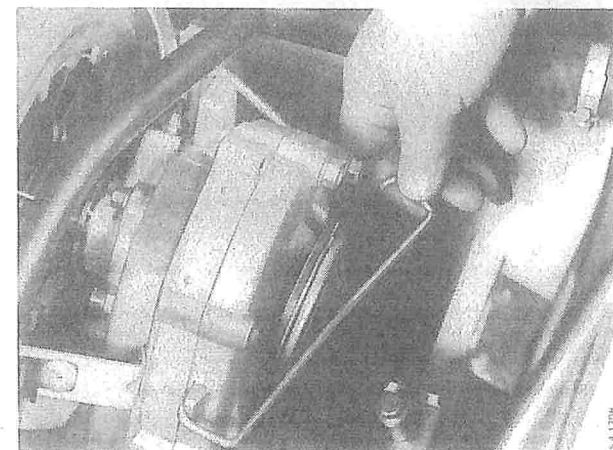

411-6 Clutch

- 6 Bolt the pressure plate unit to the flywheel.

Caution

Don't depress the clutch pedal further than necessary to remove the spacer. The lip seal may otherwise be pressed out too far, and hydraulic fluid will then leak out and the seal will be damaged.

- 7 Get an assistant to press down the clutch pedal and remove spacer ring 83 90 023.
- 8 When the clutch has been fitted, push the plastic sleeve against the release bearing.
- 9 Fit the flywheel housing cover.
- 10 Refit the clips for the battery positive cable.
- 11 Reconnect the bellows to the air cleaner and refit the throttle housing.

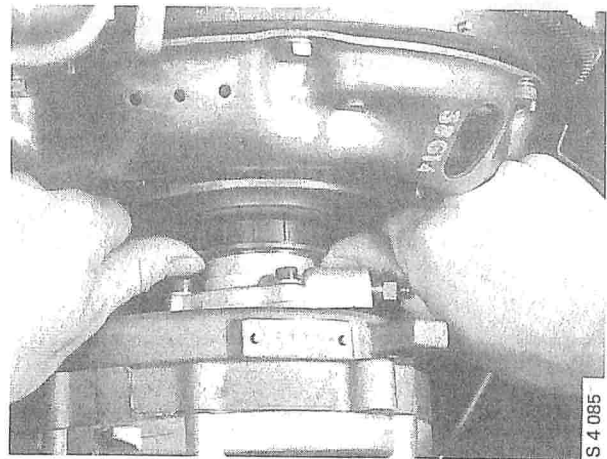
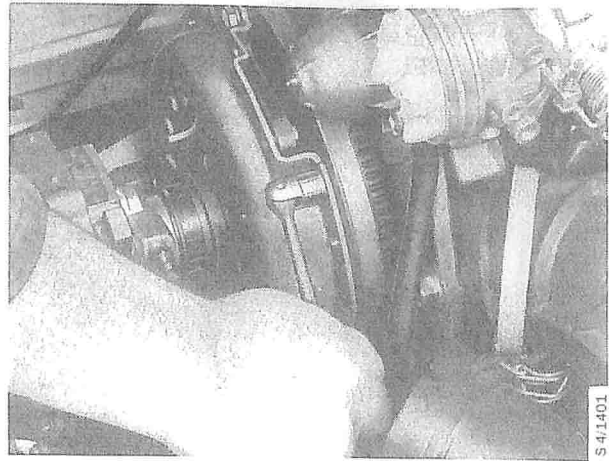

- 12 If the car has an air conditioner, fit the left-hand radiator fan.
- 13 Fit the bonnet and connect the hose to the windscreen washers.

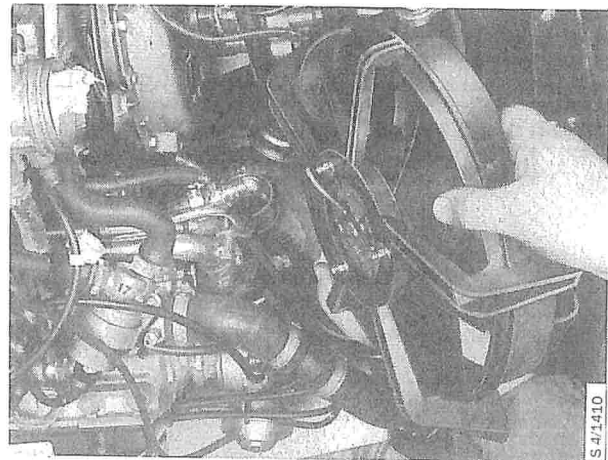

Dismantling for changing the clutch on a 900i 16 Turbo with AC

- 1 Disconnect and remove the turbocharger delivery pipe. Push a piece of cloth into the throttle housing opening to keep out dirt.

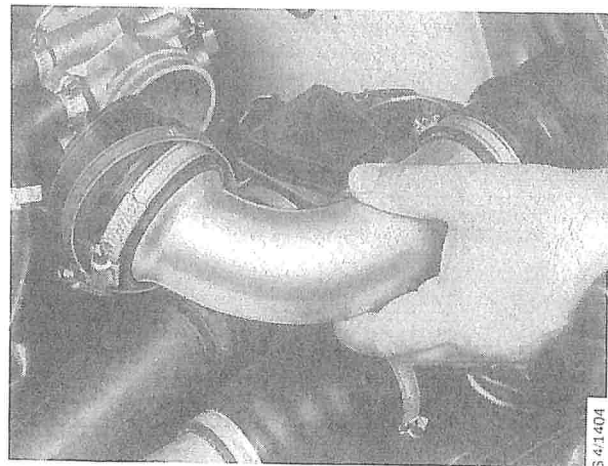

- 2 Remove the pipe between the turbocharger and the intercooler. Blank off the opening in the turbocharger.

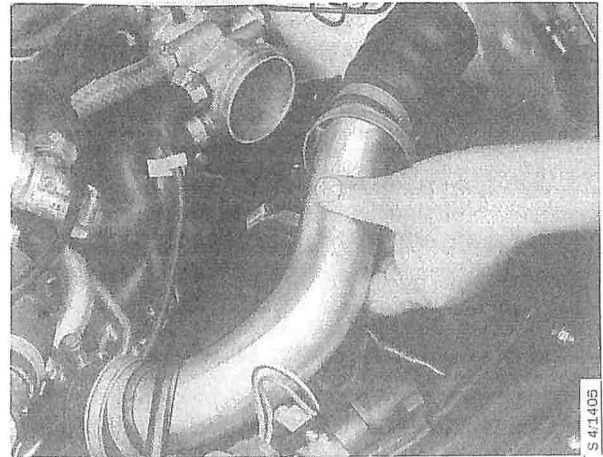

- 3 Disconnect the hose to the solenoid valve from the turbocharger suction pipe and the preheater connection in the suction pipe. Remove the suction pipe.

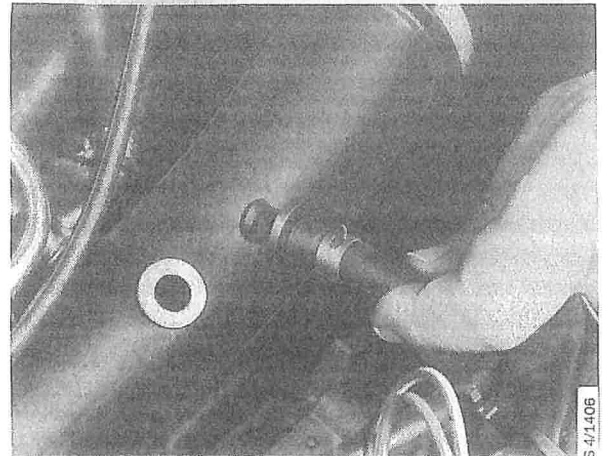

- 4 Remove the by-pass valve and its hose. Blank off the opening on the turbocharger suction side.

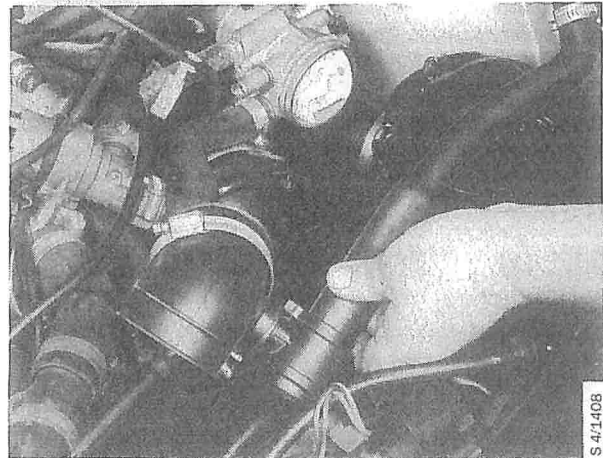

- 5 Cut off the straps retaining the cable harness and push the cable harness towards the rear. Release the battery positive cable from the flywheel housing cover.

- 6 Remove the flywheel housing cover bolts and remove the cover.

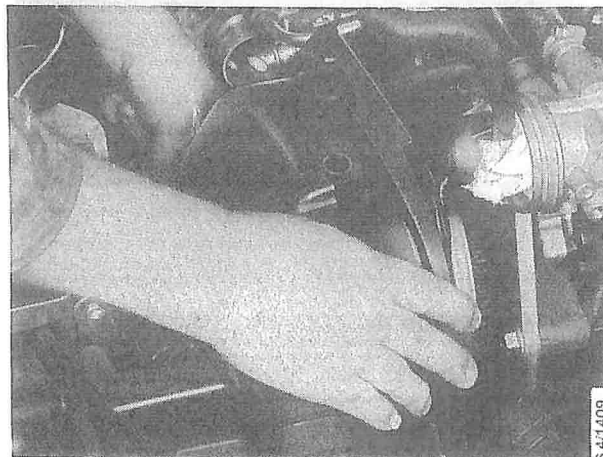

411-8 Clutch

7 Remove the left-hand radiator fan:

First remove the ignition coil and place it on the radiator cross-member. Disconnect the fan connector and remove the upper two fan bolts. The bottom bolt need only be backed off. Remove the fan.

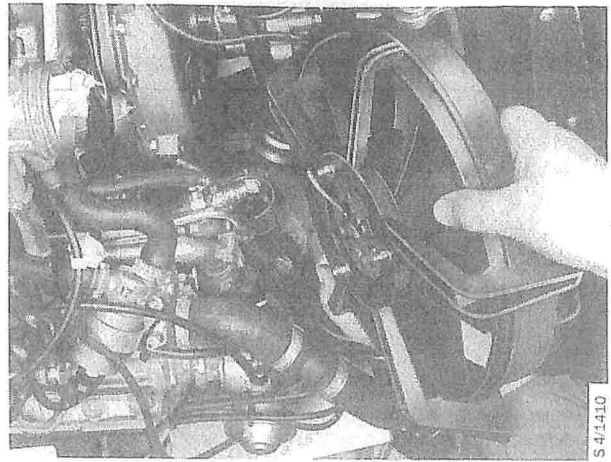

8 Fit spacer ring 83 90 023. Get an assistant to press down the clutch pedal.

9 Remove the clip and cover in front of the clutch shaft.

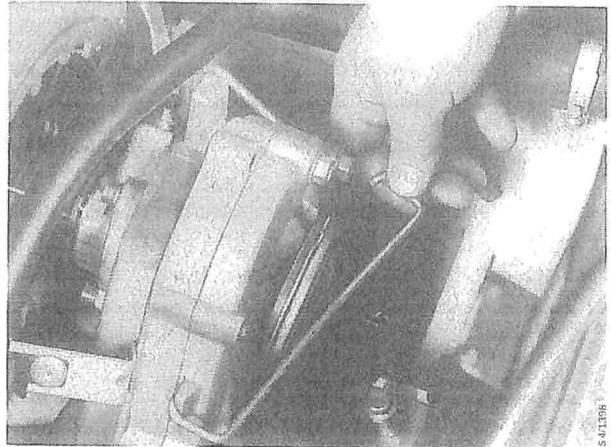

10 Remove the plastic propeller.

11 Screw an 8 mm bolt into the end of the clutch shaft and use tool 83 94 033 to withdraw the shaft. After withdrawing it, leave the shaft where it is.

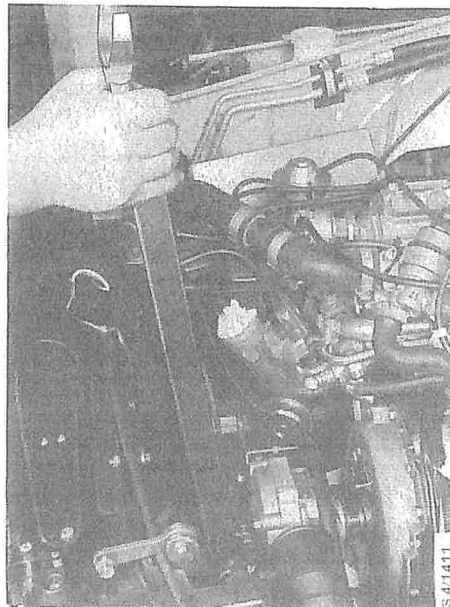

Caution

Take care not to damage the slave cylinder sleeve during removal.

- 12 Remove the three slave cylinder bolts.

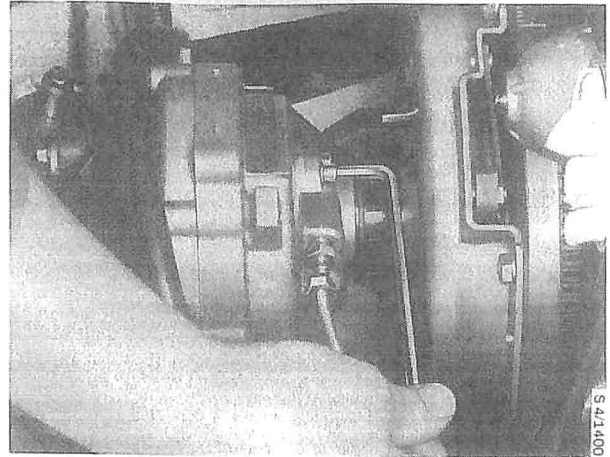

- 13 Remove the pressure plate bolts and move the pressure plate to one side, together with the slave cylinder.

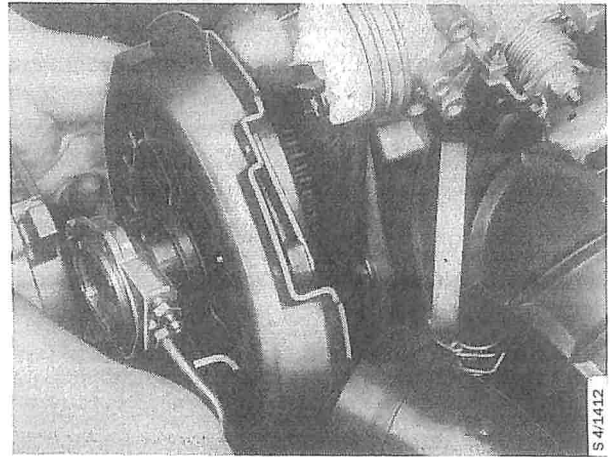
**To fit**

Before re-assembling the clutch, check the condition of the clutch shaft seal located in the primary drive chaincase, and the condition of the support bearing in the flywheel.

Note

Lubricate the clutch shaft splines sparingly with molybdenum disulphide paste or Saab Special chassis grease.

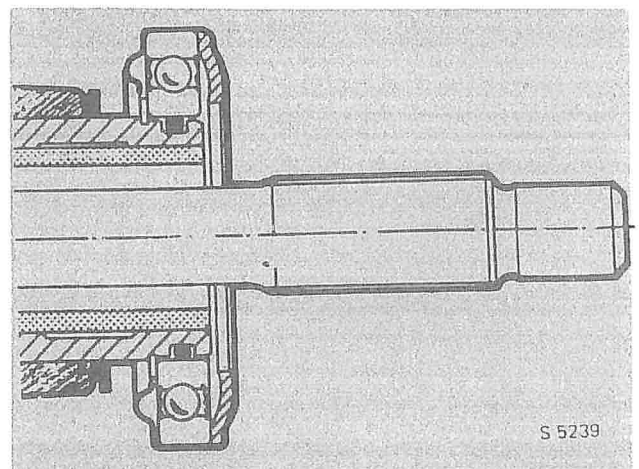

The hardened side of the release bearing must face towards the clutch.

411-10 Clutch

- 1 Fit the pressure plate unit, clutch plate and slave cylinder with release bearing together into the flywheel housing.

Push the clutch shaft into engagement with the clutch plate splines and into the support bearing in the flywheel.

Fit two of the pressure plate bolts but do not tighten them.

- 2 Finally, tap in the clutch shaft so that it is locked by the snap ring in the primary drive sprocket.

- 3 Apply thread sealing compound to the bolts. Bolt the slave cylinder to the primary chain-case.

- 4 Fit the plastic propeller to the end of the clutch shaft.
- 5 Fit the seal, cover and clip in front of the clutch shaft.

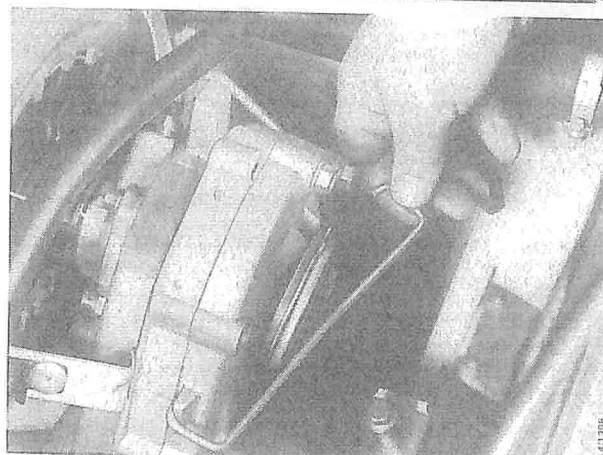
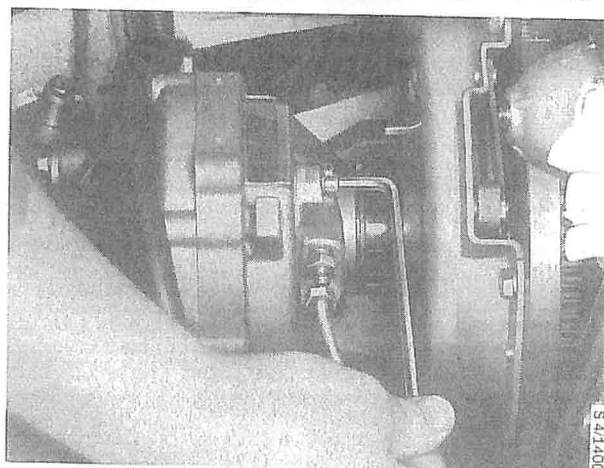
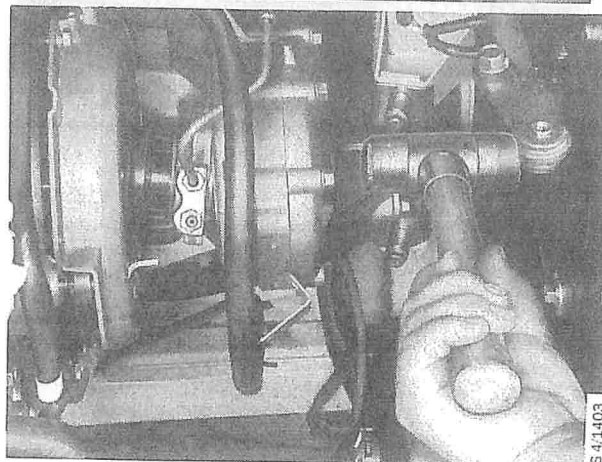
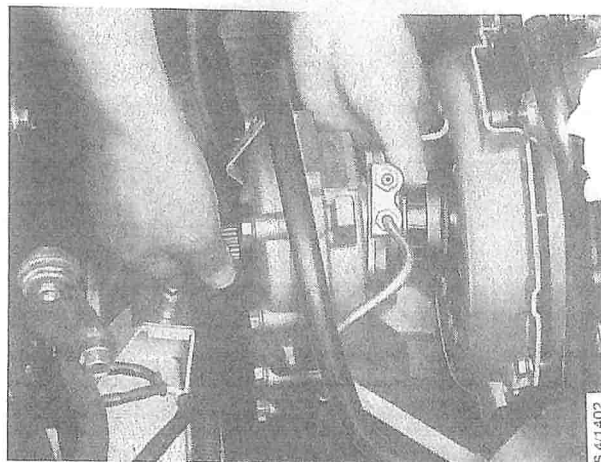

- 6 Bolt the pressure plate unit to the flywheel.

Caution

Don't depress the clutch pedal further than necessary to remove the spacer. The lip seal may otherwise be pressed out too far, and hydraulic fluid will then leak out and the seal will be damaged.

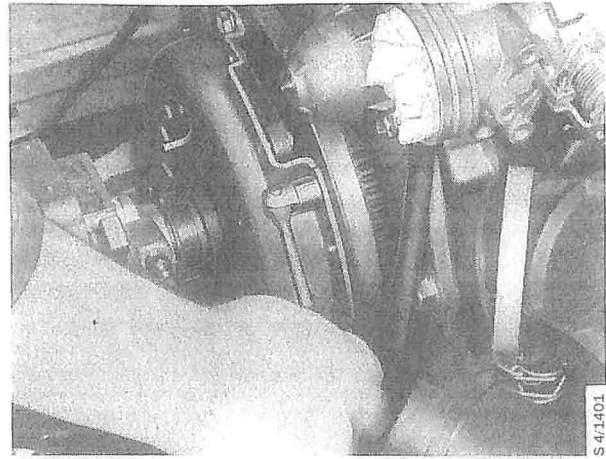

- 7 Get an assistant to press down the clutch pedal and remove spacer ring 83 90 023.

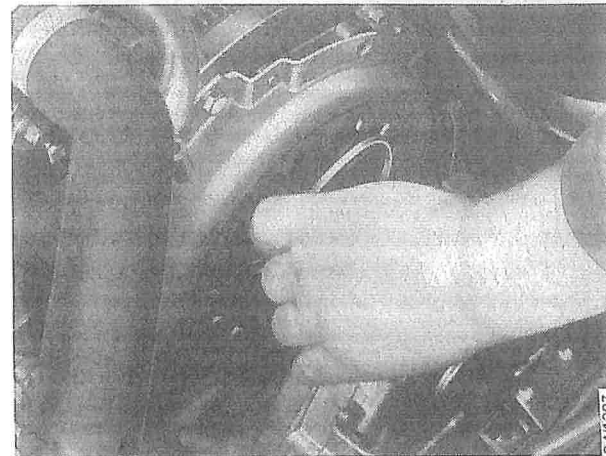

- 8 When the clutch has been fitted, push the plastic sleeve against the release bearing.

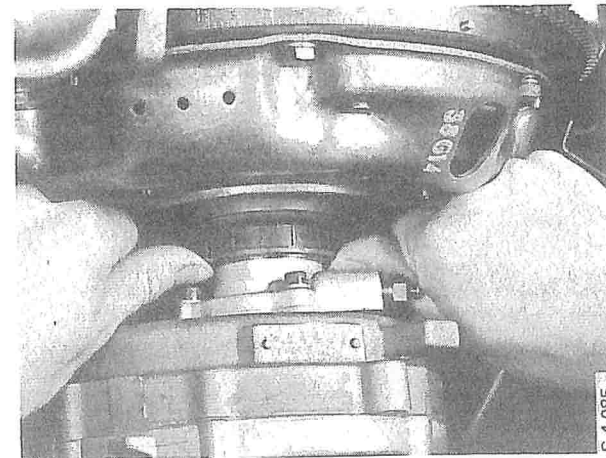

- 9 Fit the flywheel housing cover.
10 Refit the clips for the battery positive cable.

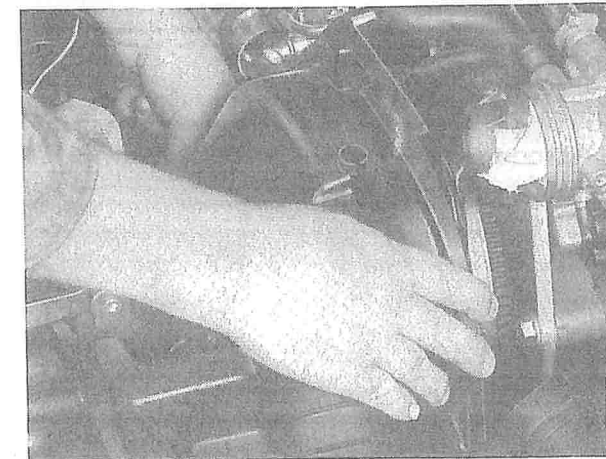

To check the clutch for wear

Remove the inspection cover from the flywheel housing cover, and then check the wear through the inspection opening.

When the distance between the front edge of the plastic sleeve and the front shoulder of the turned surface is less than 2 mm, a new clutch plate should be fitted.

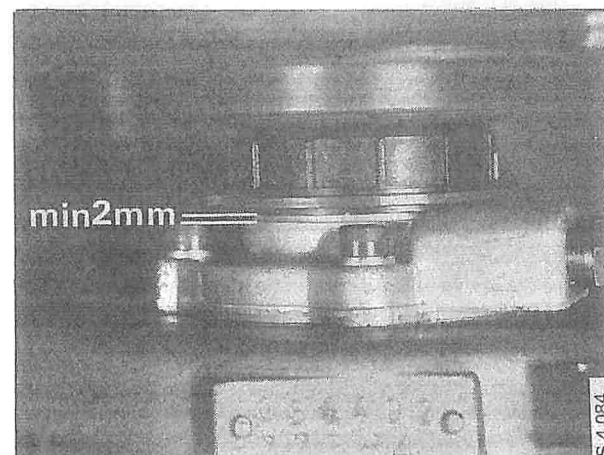
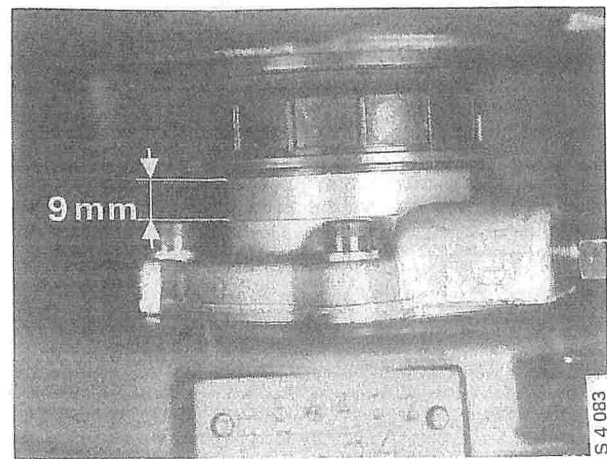

Worn clutch plate

Clutch plate

To check the clutch after dismantling and to change the clutch plate lining

- 1 Check the contact surface of the clutch plate on the flywheel. If the surface is "blued" and has hairline cracks, this is of minor importance. But if the surface is deeply scratched, the flywheel should be turned or a new flywheel should be fitted.
- 2 Check the pressure plate for scratches and misalignment, and check the diaphragm spring for wear at the contact surface with the release bearing. If the pressure plate or diaphragm spring is defective, fit a new pressure plate unit.
- 3 Check the release bearing for noise, wear or other defects.
- 4 Check the clutch plate for wear and fit a new clutch plate, if necessary.

Note

Checks on a new clutch plate:

- When the clutch plate is subjected to a load of 4230 N (948 lb) between two parallel surfaces, its thickness should be 7.11 - 7.62 mm (0.28 - 0.30 in) or 6.86 - 7.37 mm (0.27 - 0.29 in) on a Turbo clutch plate.
- The clutch plate should be completely free when the surfaces have been moved apart by 1.27 mm (0.05 in) from the position they had when the above load was applied.

Note

The flywheel is secured with bolts which have a low head, to provide space for the clutch plate damper. When fitting new bolts, make sure that the right type of bolt is used.

To check the pressure plate unit

Check the pressure plate for cracks and scratches. Use a rule and feeler gauges (see the figure) to check that the pressure plate is flat. A clearance of up to 0.03 mm (0.0012 in) is permissible at the inside diameter of the friction surface, but no clearance is permissible between the straight edge and the friction surface. Check at several points. Check that the diaphragm spring is not cracked or otherwise damaged. Check that the release bearing runs freely when it is turned while a light axial load is applied.

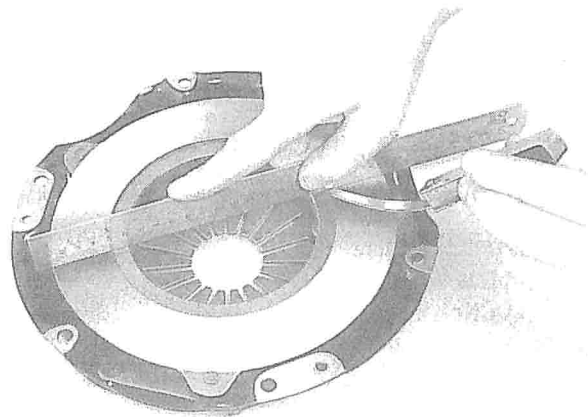

5.1799

Clutch operation

Master cylinder	412-1	Slave cylinder	412- 8
To remove the clutch pedal	412-2	To dismantle	412- 8
To remove the clutch master cylinder	412-3	To assemble	412- 9
To dismantle	412-5	To bleed the master and	
To assemble	412-5	slave cylinders	412- 9
To fit	412-6	To remove the release bearing	412-10

Master cylinder

General

The master cylinder is located below the brake servo. It is actuated by a push-rod connected to the clutch pedal. In addition to the push-rod, the master cylinder also includes a piston, piston seals and a return spring. The clutch fluid reservoir is integrated with the brake fluid reservoir, although the two are entirely separate. A hose runs from the reservoir to the master cylinder.

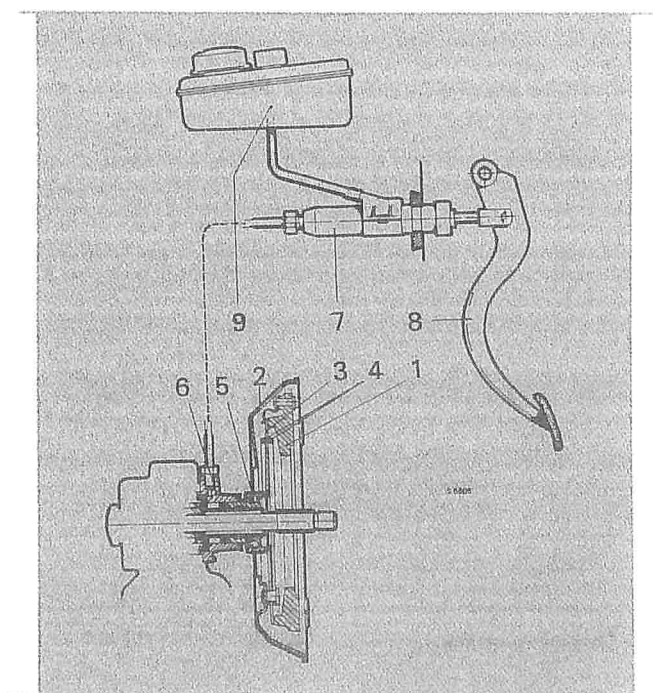

Clutch operation

- 1 Pressure plate
- 2 Housing
- 3 Diaphragm spring
- 4 Pivot rings
- 5 Release bearing
- 6 Slave cylinder
- 7 Master cylinder
- 8 Clutch pedal
- 9 Clutch fluid reservoir

To remove the clutch pedal

- 1 Remove a self-tapping screw from the left-hand outer part of the air duct.
 - 2 Lower the duct carefully so that it will not be damaged.
 - 3 Remove the clip and clevis pin from the clutch pedal.
 - 4 Remove the spring.
 - 5 Remove the pedal pivot shaft.
 - 6 Remove the pedal.
- Assemble in the reverse order.

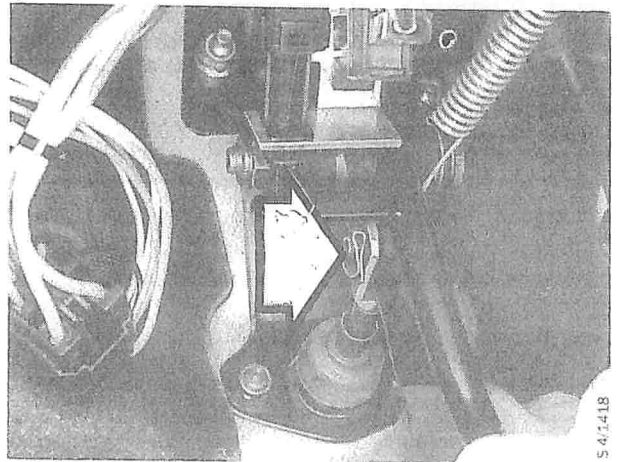
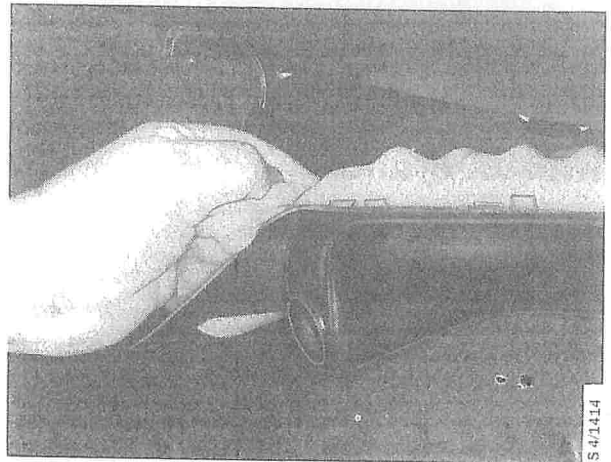
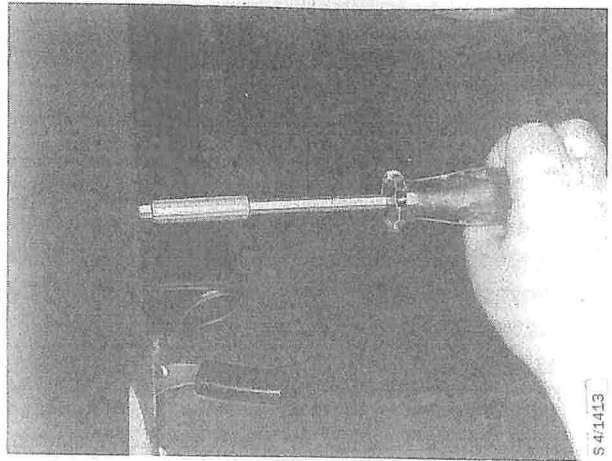

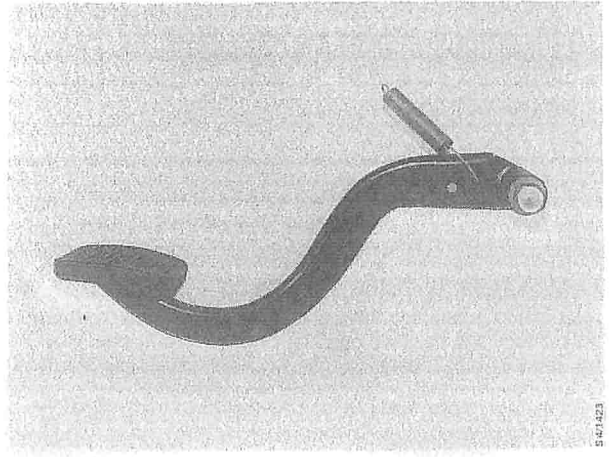

To remove the clutch master cylinder

- 1 Remove a self-tapping screw in the left-hand outer part of the air duct, and carefully fold down the trim panel and duct below the steering column.

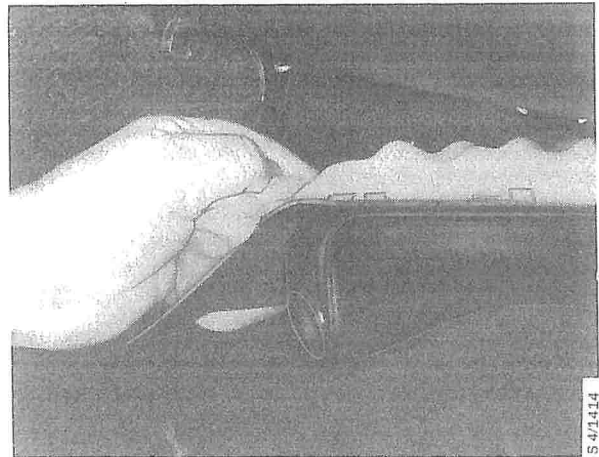
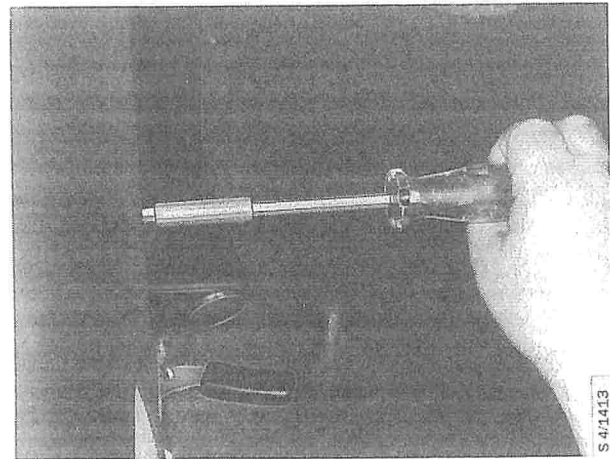

- 2 Remove the clip securing the tube to the wheel housing.

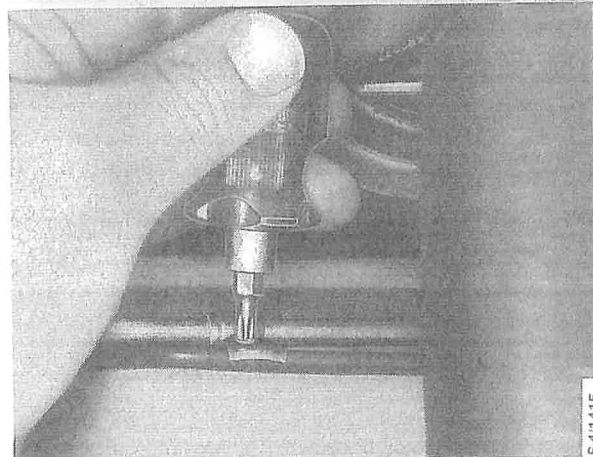

412-4 Clutch operation

- 3 Disconnect the pipe coupling from the master cylinder. Pinch the hose from the fluid reservoir with a pair of hose tongs to prevent loss of fluid.

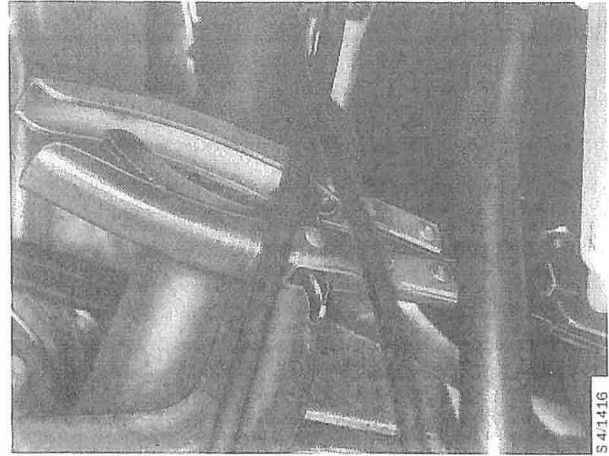
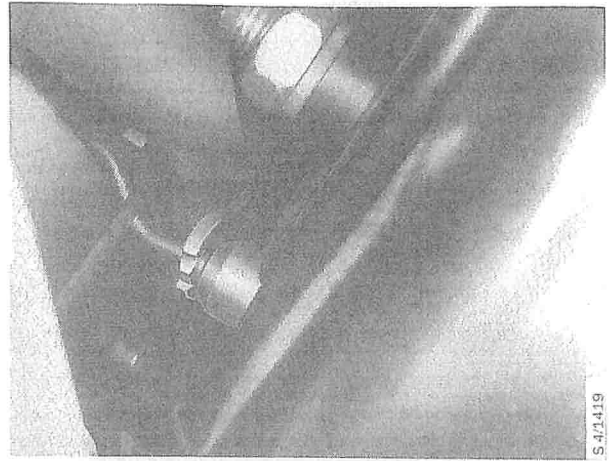

- 4 Remove the clip and clevis pin connecting the push-rod to the clutch pedal.

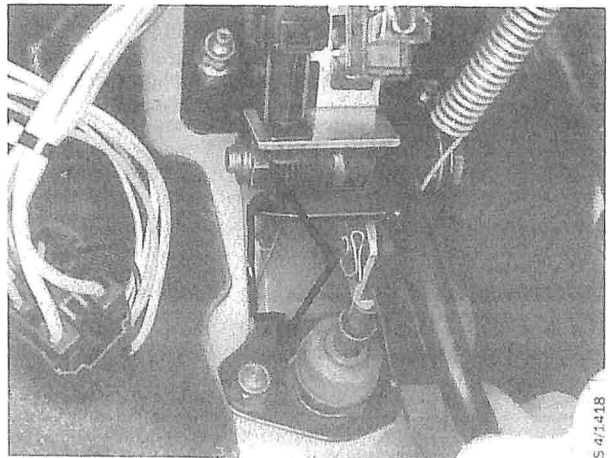

- 5 Remove the two nuts securing the master cylinder to the bulkhead.

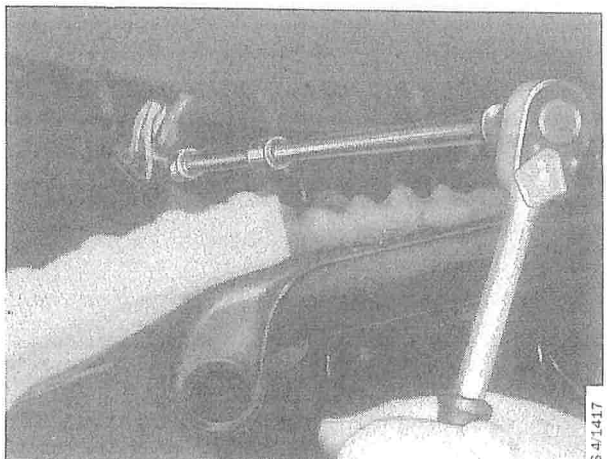

Disconnect the hose and withdraw the master cylinder from the engine compartment side.

On cars with the ABS system, remove the alternator belt tensioner and move the alternator to one side and possibly tie it in this position to enable the master cylinder to be reached.

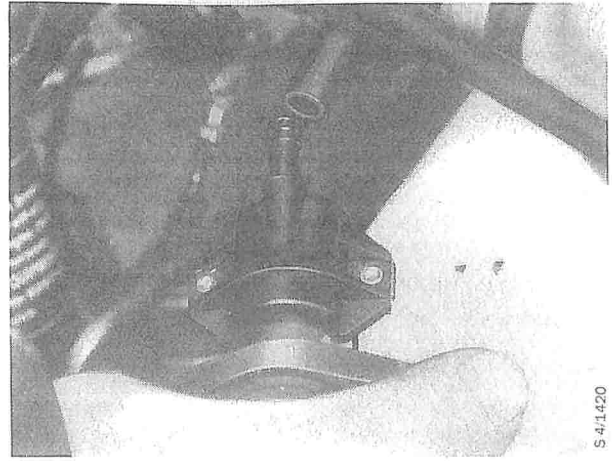

S 41420

To dismantle

Pull the dust cover toward the rear and use a pair of pliers to remove the circlip. Remove the push-rod and washer. The piston and seal will now be visible. Remove the piston, washer, piston seal and spring. Carefully remove the seal from the piston. Examine the cylinder bore. If it is smooth and unscratched, new seals can be fitted. But if the cylinder bore is uneven, fit a new cylinder. If the old seals on the piston are too large and swollen, they have probably been contaminated with mineral oil. This is the most common fault on master cylinders. Natural rubber seals are very sensitive to mineral oil, and even small quantities may cause them to swell with time. If this is suspected, change all of the seals and flush the system with clean hydraulic fluid.

To assemble

Fit the return spring and spring seat. Lubricate the piston and seals thoroughly with Girling Rubber Grease 3, and fit the seal, washer and piston with seals.

Note

Take care to fit the washer with the convex side towards the piston as shown in the figure.

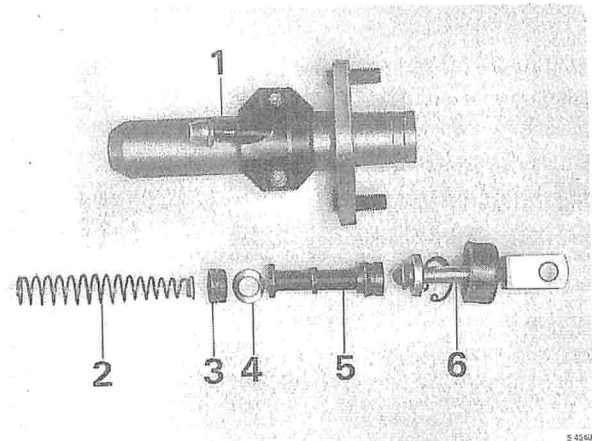

S 4540

Components of the clutch master cylinder

- 1 Housing
- 2 Spring with seat
- 3 Seal
- 4 Washer
- 5 Piston with rear seal
- 6 Push-rod with stop washers, circlip and dust cover.

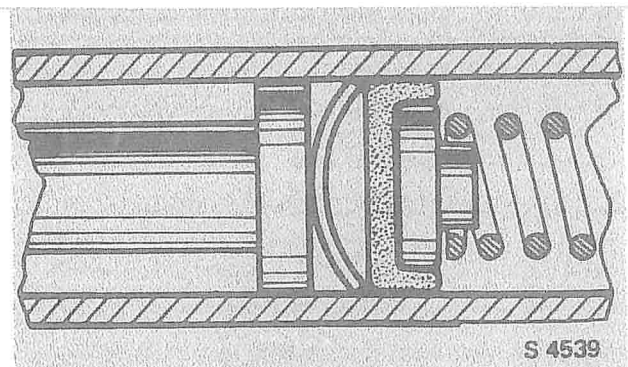

Correct position of the washer

412-6 Clutch operation

Fit the push-rod into the cylinder, and then fit the washer and circlip into the cylinder housing groove. Fit the dust cover or fit a new cover if the old one is damaged.

To fit

- 1 Fit the master cylinder to the bulkhead, fit the nuts and tighten them lightly.

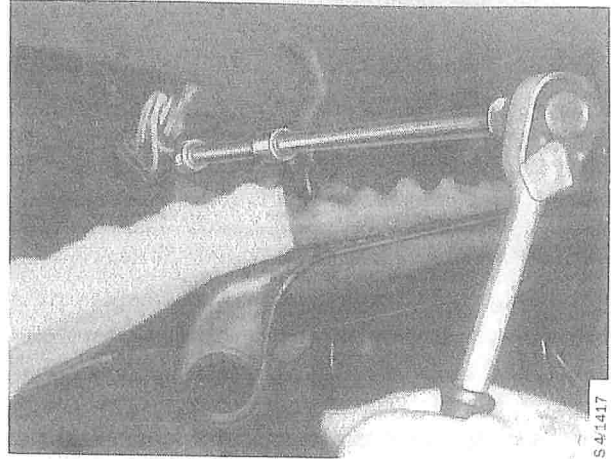

- 2 Refit the pipe coupling and connect the hose. Remove the hose tongs.

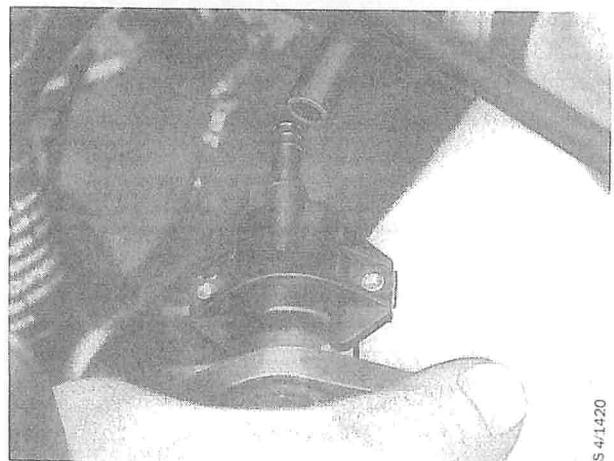
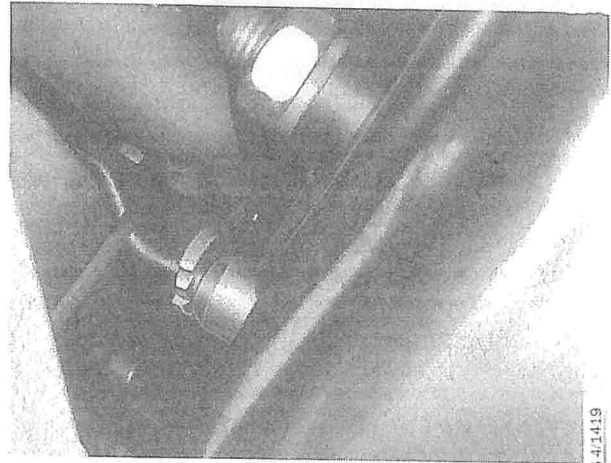

- 3 Fit the clip to the wheel housing.

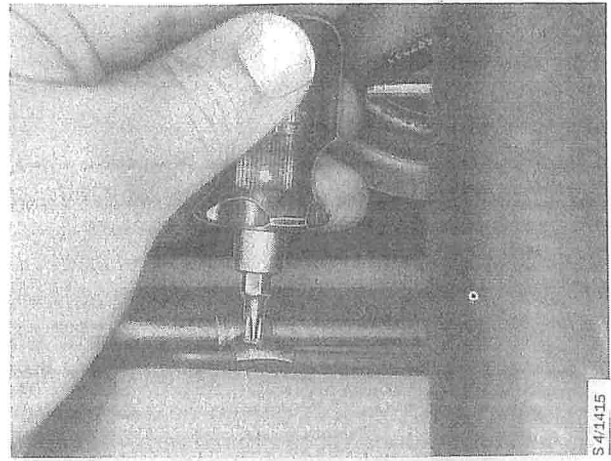

If the car has ABS brakes, refit the alternator and drive.

- 4 Tighten the two master cylinder nuts from the inside of the car. Refit the clevis pin and clip.

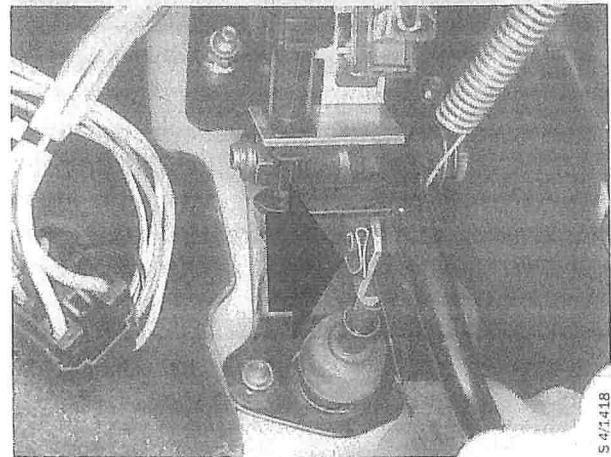

- 5 Fit the air duct and refit the self-tapping screw for the trim panel.

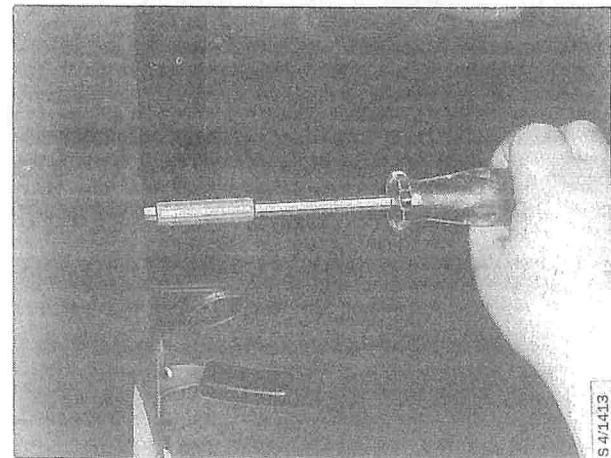

- 6 Bleed the clutch hydraulics. Use a radiator tester or a brake bleeder unit.

Slave cylinder

General

The slave cylinder is an annular hydraulic cylinder which is mounted in the flywheel housing and is designed so that the clutch shaft passes through it. The slave cylinder consists of an outer cylinder housing and an internal sleeve, with an annular piston and a lip seal arranged between them. The release bearing is secured to the piston with a circlip and is sealed with an O-ring. When the clutch pedal is depressed, the slave cylinder piston and release bearing will move against the diaphragm spring. When the pedal is released, the release bearing and piston will be returned by the diaphragm spring. The slave cylinder is equipped with a plastic sleeve (dust cover) secured by a circlip and operating against a turned surface on the piston. Its function is to prevent excessive return travel. The plastic sleeve also serves as a dust cover for the slave cylinder.

When the clutch pedal is released, the release bearing is only just clear of the diaphragm spring. Clutch adjustment is automatic, since the plastic sleeve moves along the cylinder in pace with the wear of the clutch lining.

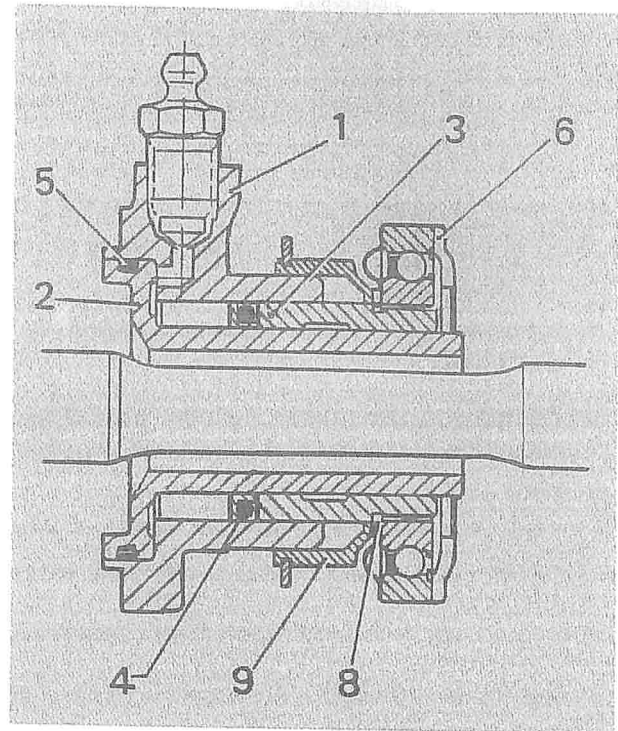

Slave cylinder

- 1 Slave cylinder housing
- 2 Sleeve
- 3 Piston
- 4 Lip seal
- 5 O-ring
- 6 Release bearing
- 7 O-ring
- 8 Circlip
- 9 Plastic sleeve (dust seal) with circlip

To dismantle

- 1 Remove the release bearing from the slave cylinder.
- 2 Press out the slave cylinder sleeve and remove the O-ring from the sleeve flange.
- 3 Remove the piston and lip seal.

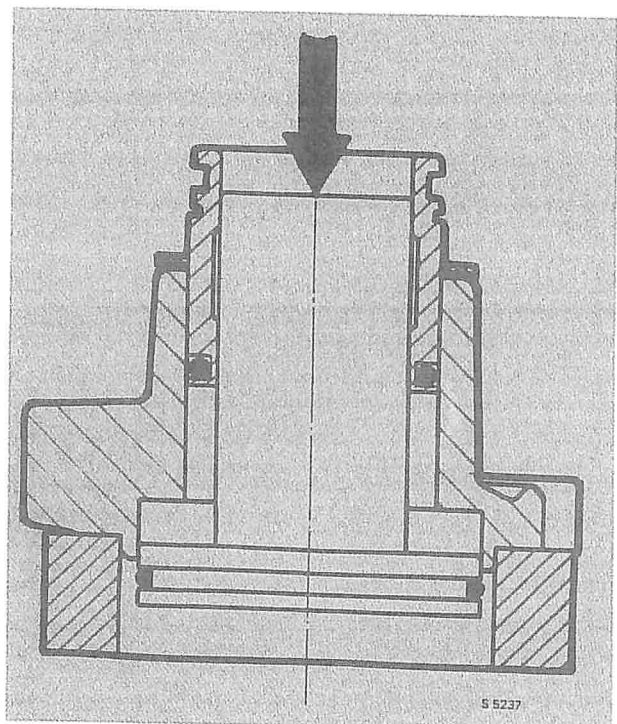

S 5237

To assemble

- Make sure that the slave cylinder is thoroughly clean. Wash the parts with brake fluid or a special cleaning fluid for hydraulic brake components, e.g. a mixture of spirits and acetone.
 - Never allow the lip seal to come into contact with mineral oil.
 - Apply a thin coat of Castrol Rubber Grease to the lip seal (not in the groove) and the piston (but not to the O-ring).
- 1 Fit a new O-ring to the sleeve flange.
 - 2 Slide the lip seal onto the sleeve. Dip the sleeve flange in brake fluid and insert the sleeve into the cylinder. Push the lip seal part of the way into the cylinder.
 - 3 Align the sleeve and cylinder by inserting the piston. Fit the circlip, the O-ring and the plastic sleeve with circlip after the piston has been inserted between the sleeve and cylinder.
 - 4 Place the slave cylinder on a suitable support, such as an old slave cylinder piston, and press the sleeve into the cylinder.
 - 5 Fit the release bearing to the piston. Make sure that the bearing faces the right way.

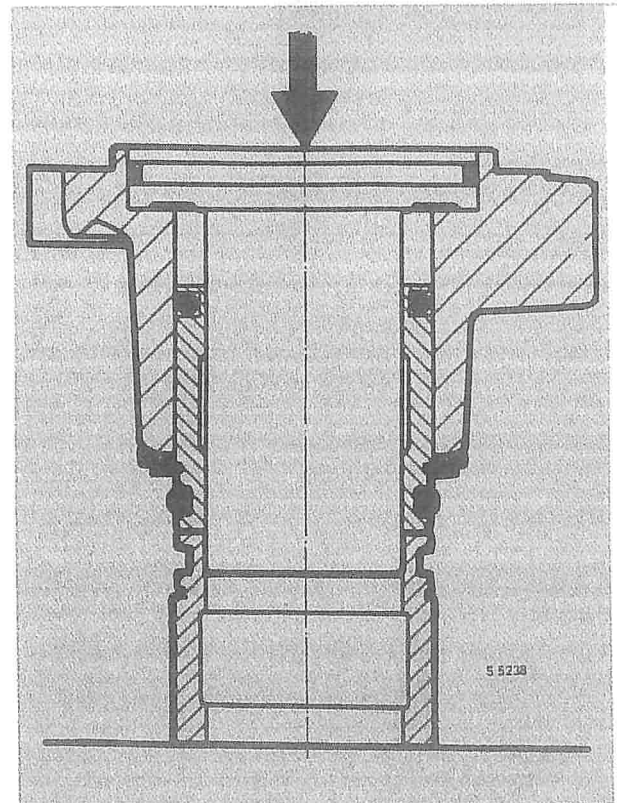
**To bleed the master and slave cylinders**

- 1 Connect a hose (about 6 mm inside diameter) to the slave cylinder bleeder nipple, and place the free end of the hose in a container which is partially filled with brake fluid.
- 2 Fill the master cylinder reservoir with brake fluid.
- 3 Open the slave cylinder bleeder nipple half a turn.

412-10 Clutch operation

- 4 Fit the cooling system tester to the hydraulic fluid filler opening.
- 5 Pump once or twice until all air has been purged from the system.
- 6 Shut off the slave cylinder bleeder nipple.
- 7 Press the clutch pedal and check that no air is left in the system.

To remove the release bearing

To remove the release bearing, proceed in the same way as for dismantling the clutch. The release bearing is removed together with the clutch and slave cylinder.

General

Gearbox

The gearbox is designed specifically for front-wheel drive cars, with all shafts, gearwheels, differential and inner universal joints forming an integral unit.

All forward gears are synchromesh, whereas reverse is engaged by means of a sliding gear. The shafts are journalled in the gearcase in ball bearings and taper roller bearings. The output shaft gearwheels are journalled in bushes (the rear end of the layshaft is mounted on a needle bearing, whereas the input gearwheel runs on loose rollers). All gearwheels except reverse are permanently in mesh and have helical teeth.

The front part of the transmission assembly consists of a primary drive, driven by the engine through the clutch and transmitting the engine output to the gearbox itself. The gearbox is located underneath the engine, and part of the gearcase serves as the engine oil sump.

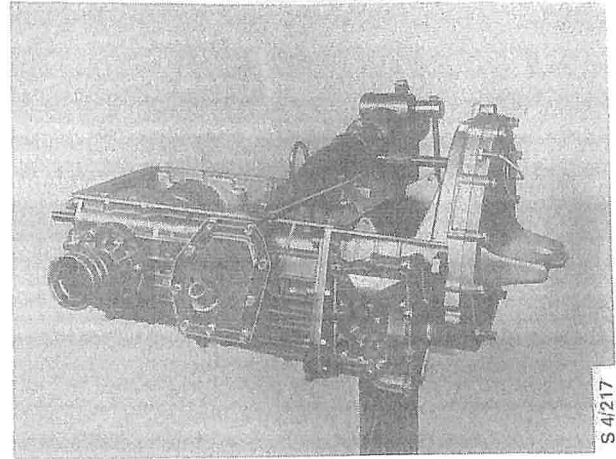

Gearbox in a stand

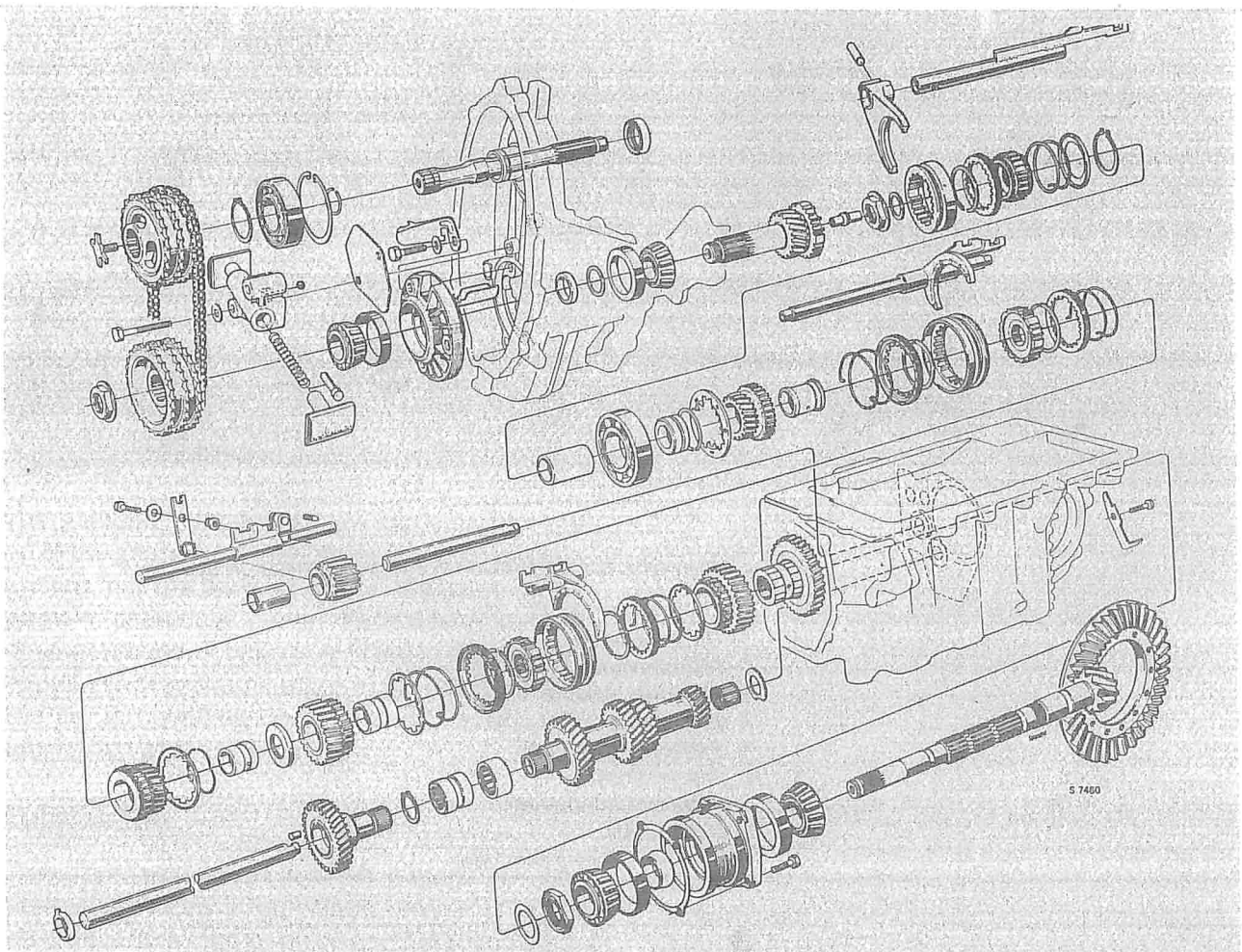

Exploded view of the transmission assembly

The operation of the transmission system is illustrated by the diagram below. Engine power is transmitted through the clutch and primary chain drive to the gearbox input shaft. In 1st gear, power is transmitted through the rear layshaft pinion to the output shaft through the gearwheel for 1st gear which is journalled on the output shaft and is locked to the shaft by a sliding sleeve.

In 2nd, 3rd and 4th gears, power is transmitted to the output shaft in a similar manner, the gearwheels for 2nd, 3rd and 4th gears being locked to the output shaft by corresponding sleeves. In top gear, the input shaft is locked to the output shaft by means of a sleeve, and power is thus not transmitted through the layshaft.

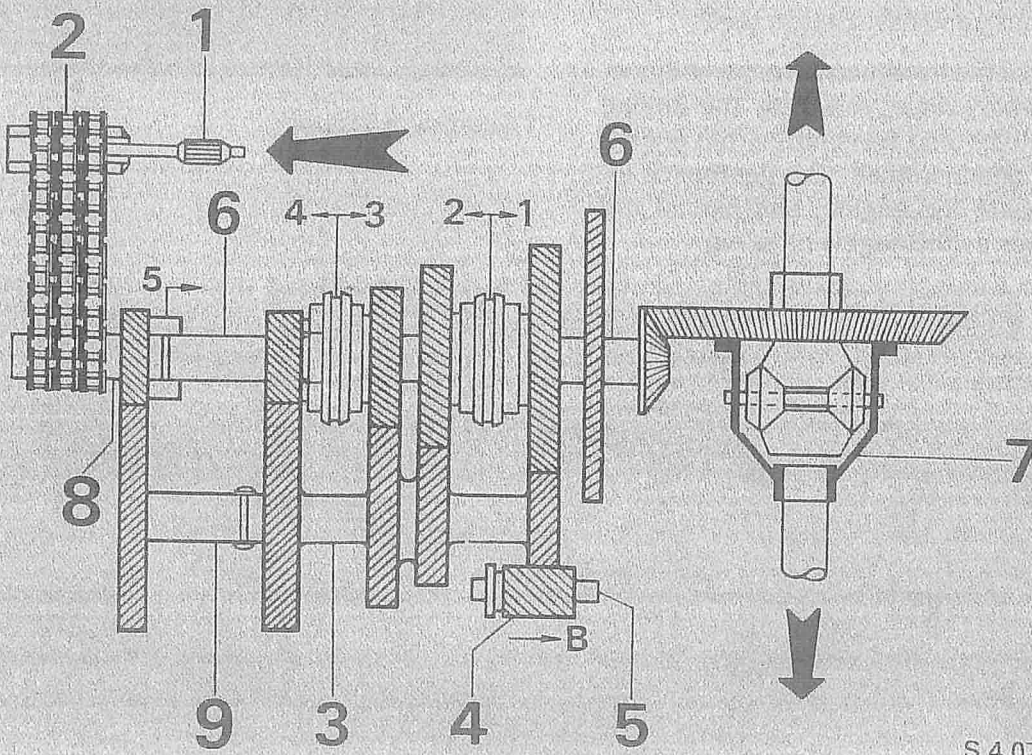

Schematic arrangement of the transmission system

- 1 Clutch shaft
- 2 Primary chain drive
- 3 Layshaft pinions
- 4 Reverse gear
- 5 Reverse gear shaft
- 6 Output shaft
- 7 Differential housing
- 8 Input shaft
- 9 Layshaft drive gearwheel

Reverse gear consists of a shaft and a gear journaled on it and in constant mesh with 1st pinion on the layshaft. The reverse gear can be engaged into mesh with a gearwheel on the output shaft. This gearwheel is located behind 1st gear on the output shaft. When reverse gear is engaged, power is thus transmitted from the layshaft pinion to the reverse gear and then to the gearwheel on the output shaft. This arrangement reverses the direction of rotation of the output shaft.

of the primary chaincase lubricates the chains, sprockets and input shaft bearing. Excess oil is returned to the primary chaincase and the main gearcase by two oil catchers, which lubricate the output shaft gearwheels. The oil flows through drilled oilways in the input and output shafts, through a connecting pipe to four lubrication points on the output shaft for lubricating the gearwheel bearings.

Ventilation

A vent on the chaincase cover compensates for pressure changes in the gearbox.

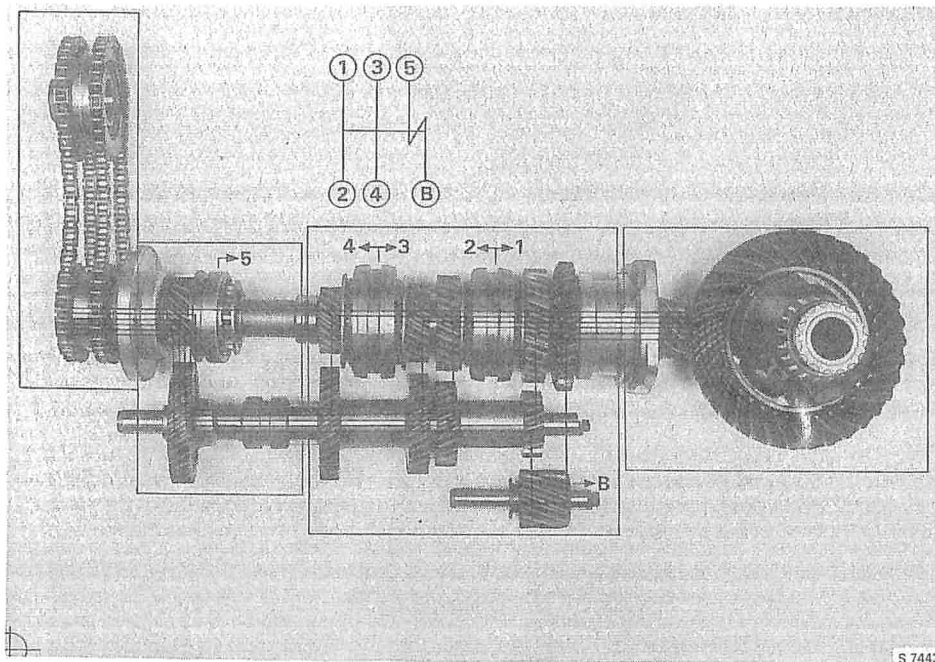

Lubrication system

General

The gearbox components are lubricated by the oil in the gearcase sump. Holes in partition walls ensure that the oil level will be the same in the primary chaincase, main gearcase and final drive gearcase. A ball valve fitted in the primary chaincase prevents changes in the oil level when the car is travelling downhill and thus ensures lubrication of the final drive.

Lubrication

The crown wheel and layshaft pinions are partially submerged in oil. When the car is under way, oil is delivered by an oil catcher to the primary drive chaincase. The oil collected in the sump

Filling with oil after repair or reconditioning of the gearbox

Pour 0.3 litres of oil into the primary chaincase through the cover in front of the clutch shaft end. Pour the remaining 2.7 litres of oil into the gearcase. About 2.6 litres of oil are needed before oil will overflow through the hole into the primary chaincase. The lowest point of the overflow hole is level with the MAX mark on the dipstick.

Oil

Engine oil is used for lubricating the transmission system. The oil should be changed during the 2000 km service, and then only after repair or reconditioning of the gearbox. Use the oil recommended in the specification for topping up. Use the dipstick on the right-hand side of the gearbox for checking the oil level.

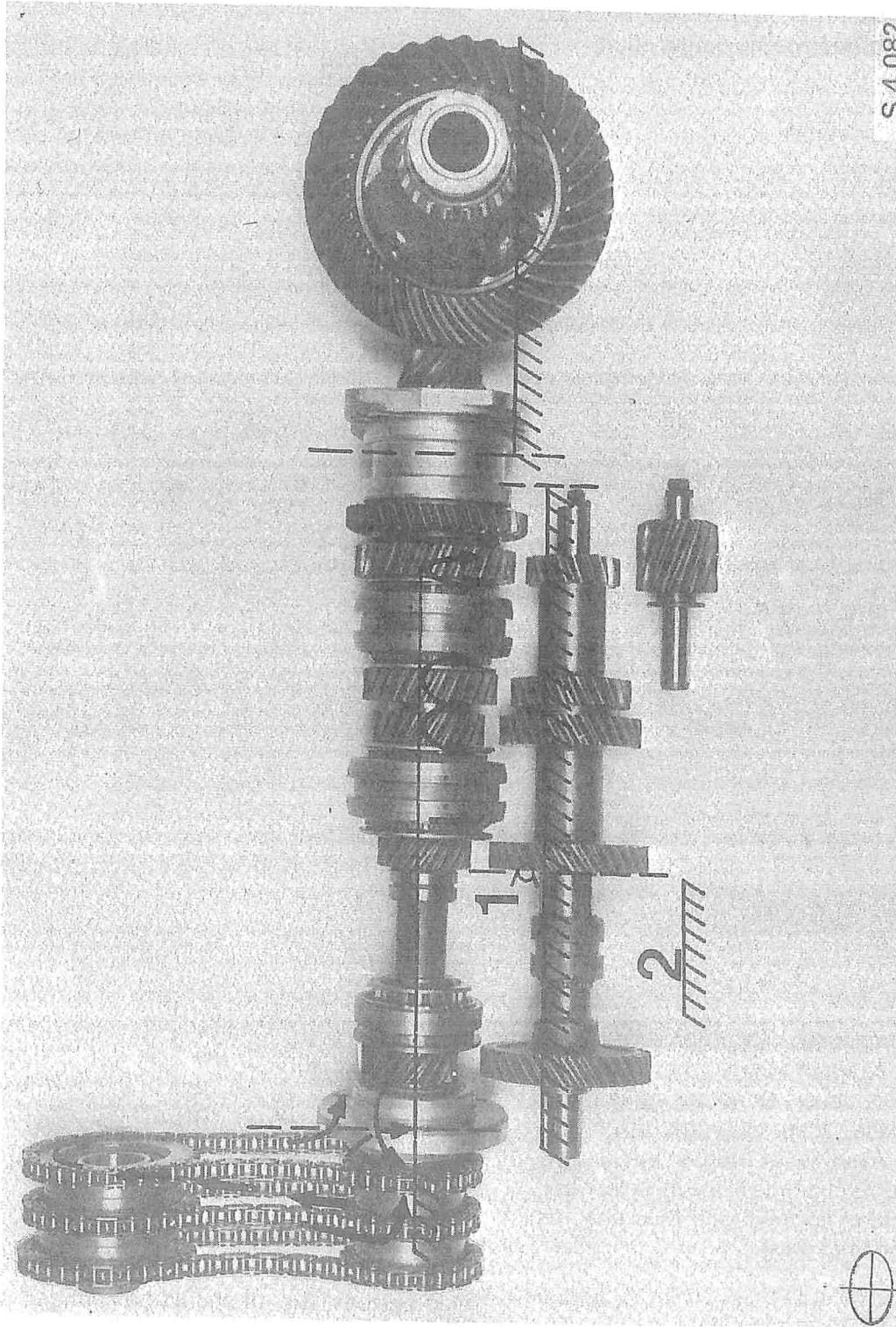

S 4 082

- 1 Ball valve
- 2 Oil level

Primary drive

The primary drive is a triplex chain transmission. A chain tensioner consisting of two spring-loaded, hydraulically damped tensioner pads is located between the two sides of the chain. The oil trap of the chain tensioner housing is continually topped up with oil from the primary chain-case. Non-return valves in the oilways between the oil trap and the tensioner pad cylinders provide the hydraulic damping.

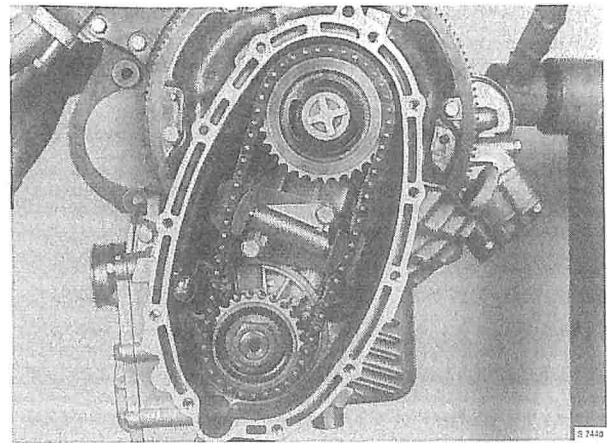

Primary drive

Synchromesh mechanism

The synchromesh mechanism shown in the figure performs as follows:

As the synchromesh sleeve is moved into engagement with the dog teeth of the gearwheel for 2nd gear, for instance, the internal cone of the sleeve will first come into contact with the spring-loaded baulk ring which is in engagement with the dog teeth of the gearwheel. At its outermost position, the baulk ring can turn about half a tooth pitch in relation to the gearwheel. If 2nd gearwheel is running at a different speed from that of the output shaft at the instant when 2nd gear is to be engaged and the sleeve begins to move in the direction towards 2nd gear position, the sleeve will be restrained by the teeth on the baulk ring which will have turned in relation to the dog teeth on the gearwheel. The friction between the conical faces of the sleeve and baulk ring will ensure that the sleeve and gearwheel are running at the same speed. The torque on the baulk ring will then be reduced, so that dog teeth of the baulk ring and sleeve can be slid into engagement with the dog teeth of the gearwheel.

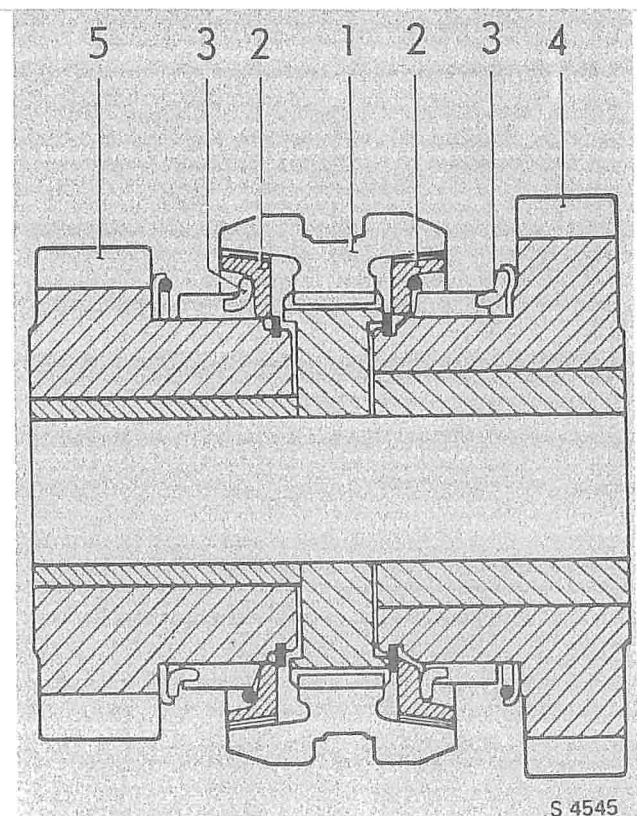

Synchromesh mechanism

- 1 Synchromesh sleeve
- 2 Baulk ring
- 3 Spring
- 4 1st speed gearwheel
- 5 2nd speed gearwheel

The gearbox is equipped with a brake which ensures smoother engagement of reverse gear. The brake consists of a spring mounted on the selector rod. When reverse gear is selected, the spring applies slight pressure to the 1st/2nd selector fork, thus braking the gears by means of the 1st synchromesh mechanism.

Differential, etc.

The differential consists of two differential pinions and two differential wheels, i.e. one for each drive shaft. The differential pinions and differential wheels are bevel gears with spur teeth. The differential wheels are splined onto the universal joint drivers. The crown wheel, which is driven by the gearbox output shaft, is bolted to the differential housing.

The speedometer drive gear is secured to the differential housing by means of a clip. Its rotation is transmitted by a worm gear to the speedometer cable.

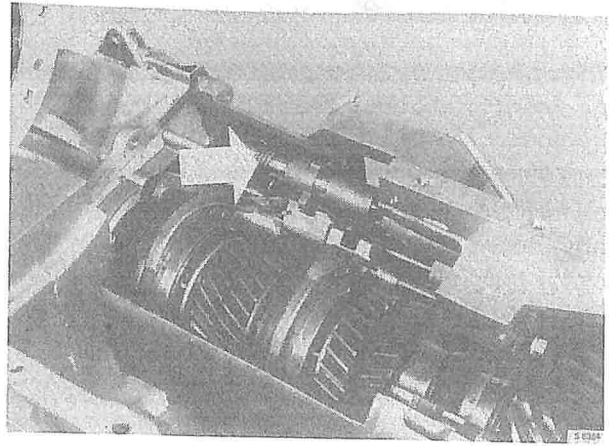

Reverse gear brake

Removing and fitting

To remove and fit
(car with B201 engine) 431- 1

To remove and fit
(car with B202 engine) 431-26

To separate the engine (B201 and
B202) from the gearbox 431-47

To remove and fit (car with B201 engine)

The removing and fitting procedure described here is for a car with the B201 Turbo engine with intercooler, catalytic converter and water-cooled turbocharger.

For other models and engine versions, the description should be adjusted to suit each individual case.

To remove

- 1 Remove the bonnet by releasing the links at each hinge, and disconnect the hose for the washers.

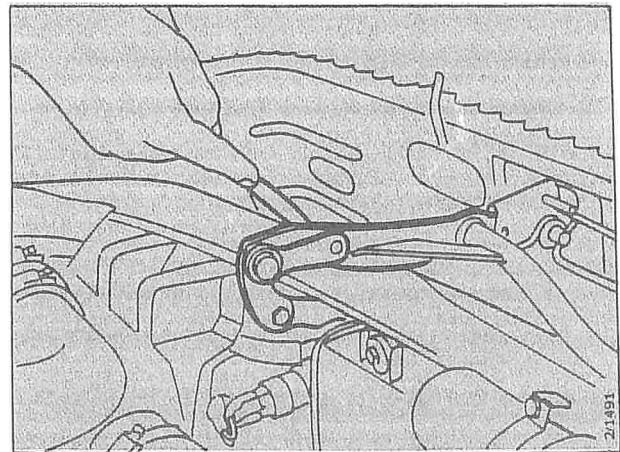

Place the bonnet securely, such as by it leaning against a wall, to prevent it from being damaged.

431-2 Removing and fitting

- 2 Fit tool 83 93 209 between the right-hand upper wishbone and the body. Turn the steering wheel to the right-hand lock and fit the tool from the wheel housing side.

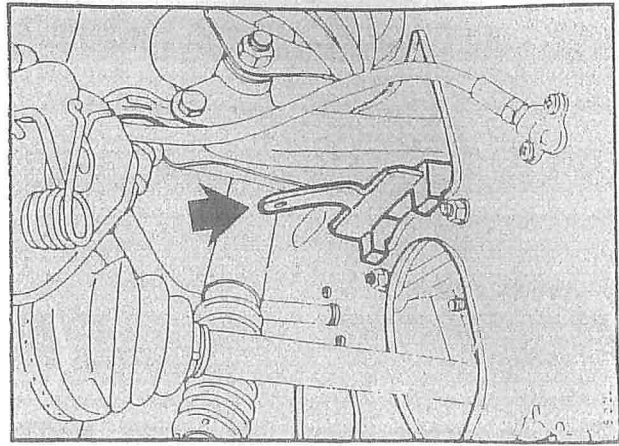

- 3 Disconnect the cables from the battery. Remove the battery (Turbo).
- 4 Remove the exhaust pipe flange bolts.

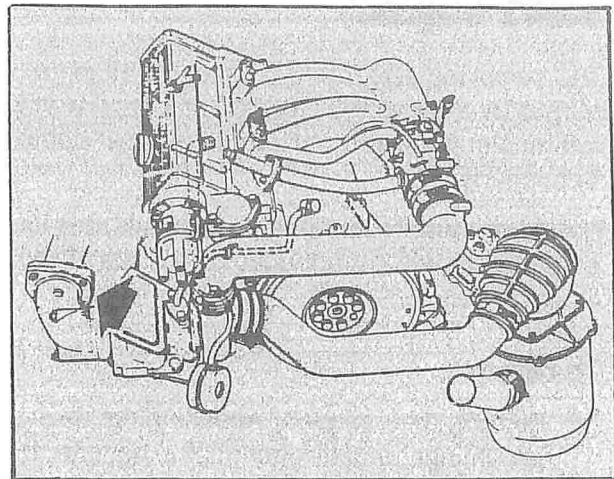

- 5 Back off the right-hand front wheel nuts.
- 6 Drain the oil from the steering servo pump reservoir.
- 7 Lift the car.
- 8 From the underside of the car:
 - a Remove the nut and carefully tap out the taper pin from the selector rod. Separate the selector rod joint.

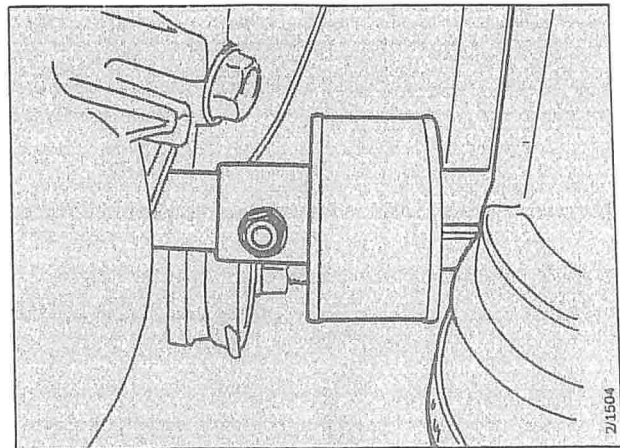

b Disconnect the speedometer cable.

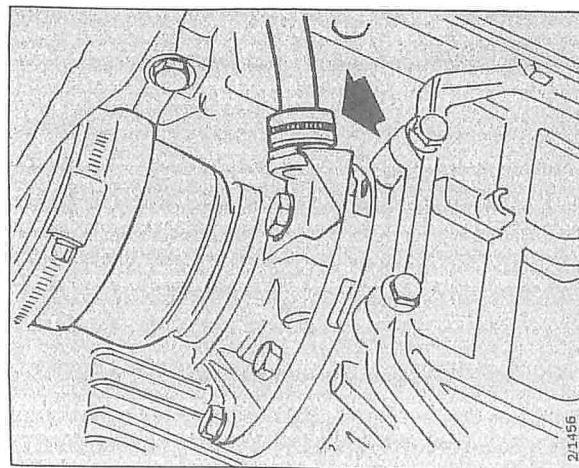

c Remove the bolts for the exhaust pipe support bracket.

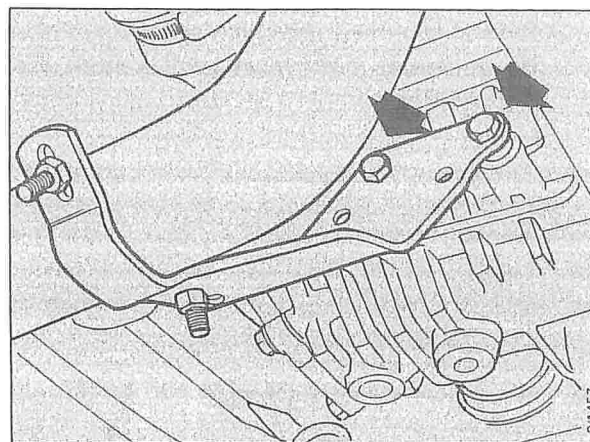

d Release the clips on the inner universal joints and remove the gaiters from the universal joint drivers.

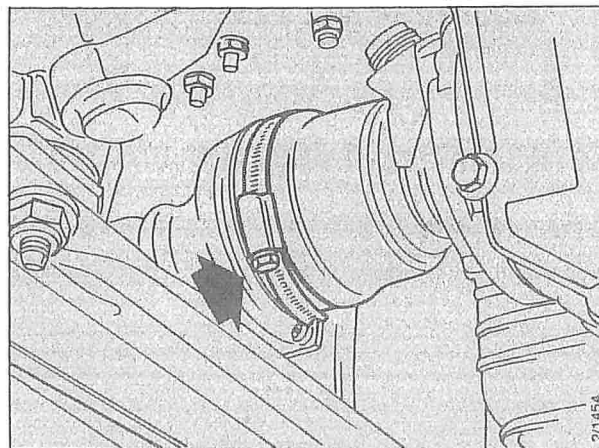

9 Lower the car to a suitable working height.

10 Remove the right-hand front wheel.

431-4 Removing and fitting

- 11 Release the end piece from the lower wishbone.

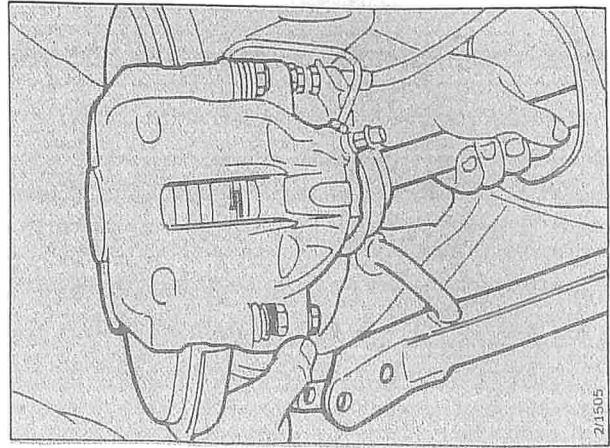

- 12 Separate the universal joint on the right-hand side, move the drive shaft forward of the universal joint driver and support it in this position.

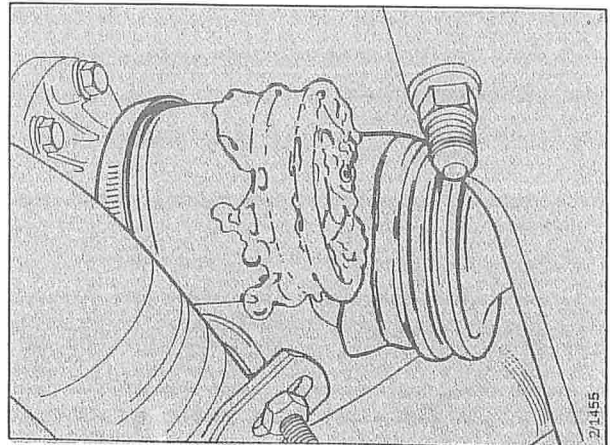

- 13 Release the coupling on the delivery side of the steering servo pump. Plug the pipe and avoid spilling oil on the engine mounting.

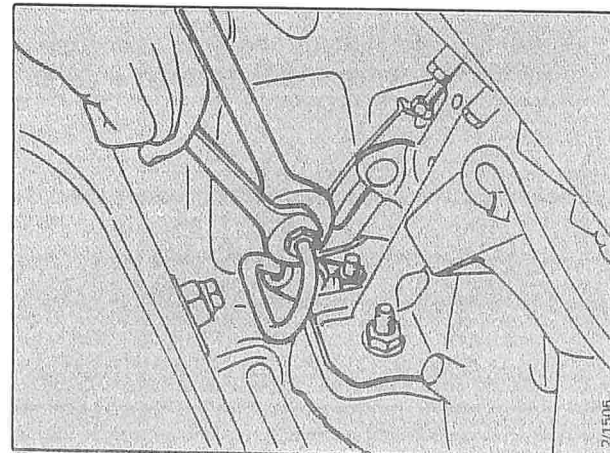

- 14 Cars with AC:

Screw out the tensioner and remove the AC compressor drive belt.

- 15 Remove the drain plugs from the underside of the engine block and radiator, and drain the coolant.

16 Disconnect the coolant hoses at:

- a Heat exchanger valve

Note

Mark the hoses to make sure that they will be re-connected to the right places.

- b Expansion tank
- c Thermostat housing

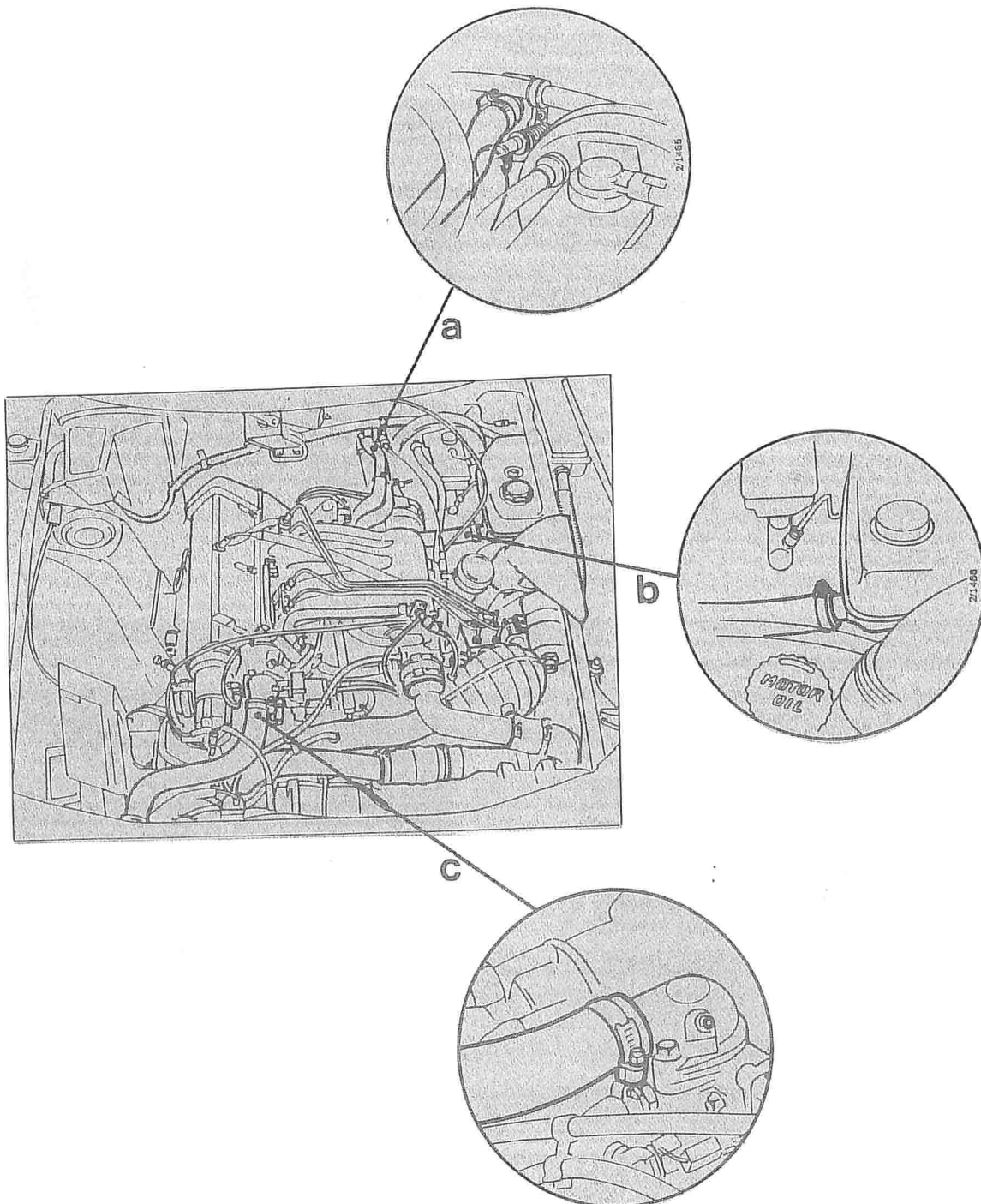

431-6 Removing and fitting

- 17 Disconnect the solenoid valve signal hoses from the valve.

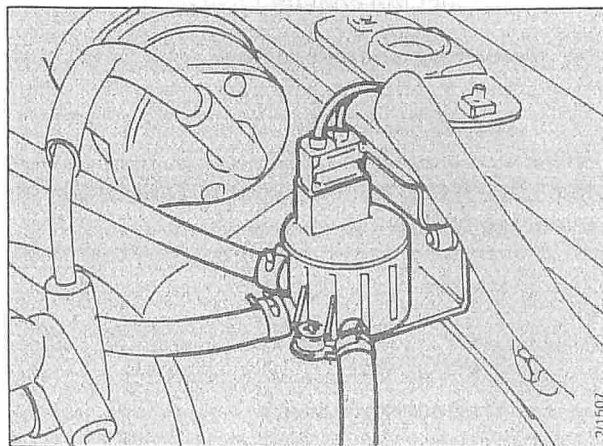

- 18 Remove the turbocharger delivery pipe between the intercooler and the throttle housing.

- 19 Remove the rubber bellows at the fuel distributor.

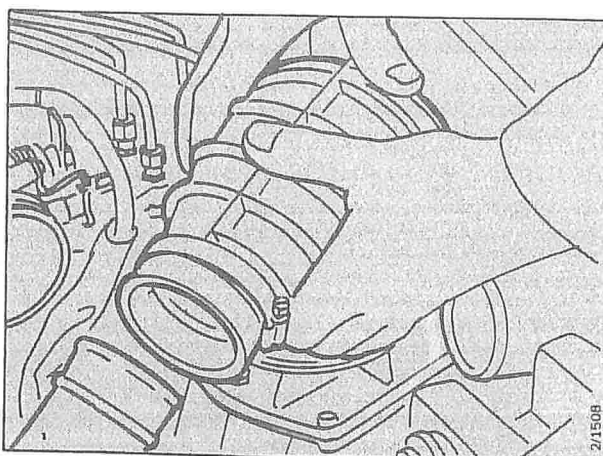

- 20 Remove the cover over the intercooler.
Remove the intercooler, together with the air pipe.

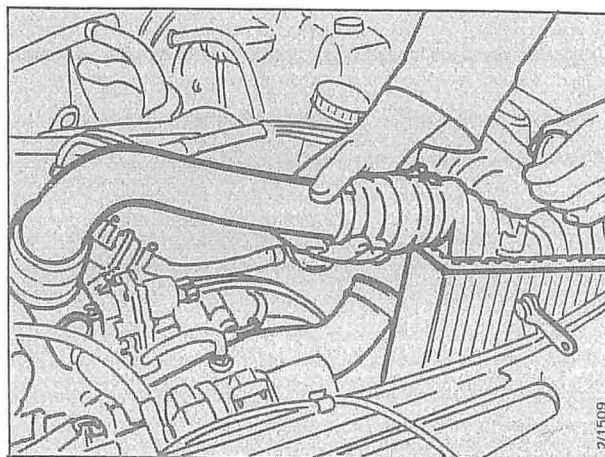

Fit a blanking-off cover to the turbocharger suction pipe.

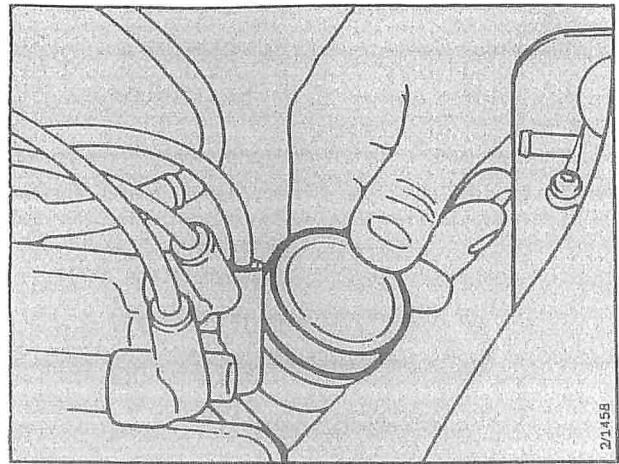

21 Remove the fuel distributor and the air cleaner as follows:

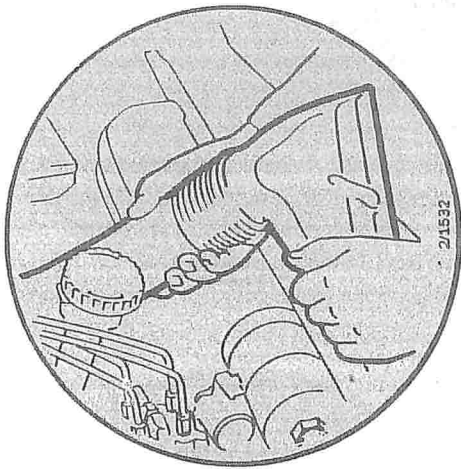

a Remove the air cleaner "snorkel".

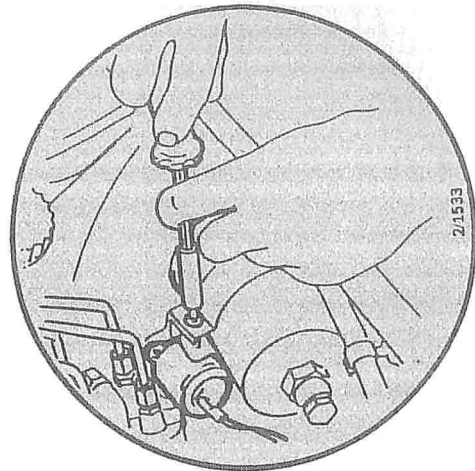

b Disconnect the vacuum hose from the pressure switch, remove the retaining screw and move the switch to one side.



c Disconnect the fuel hoses from the control pressure regulator. Use two spanners.

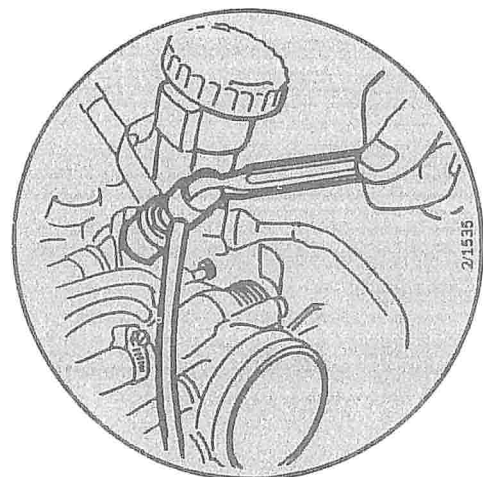

d Disconnect the fuel hose from the cold-starting valve.

Note

Carefully check the run of hoses to the fuel distributor and note the various connections. Mark the hoses, if necessary.

- e Disconnect from the fuel distributor:
- the hose from the fuel filter (1)
 - the hose from the fuel-boosting valve (2)
 - the fuel return hose (3)
 - the hose for the control pressure regulator and fuel-boosting valve (4)

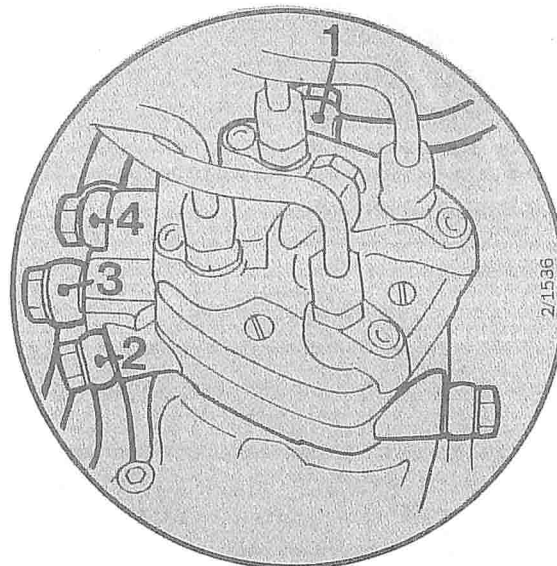

- f Disconnect the fuel pipes from the injection valves. Use two spanners.

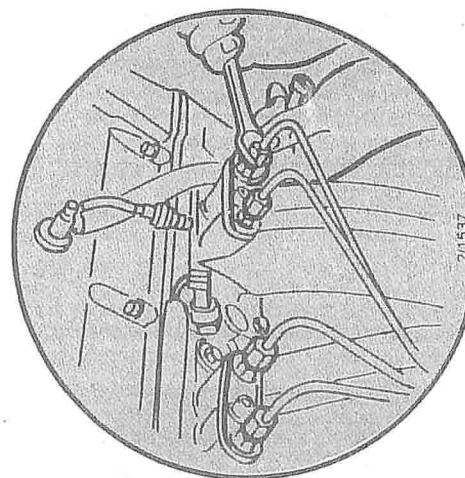

- g Disconnect the earth cable at the fuel distributor.

Release the clips and lift off the fuel distributor with air cleaner and fuel hoses.

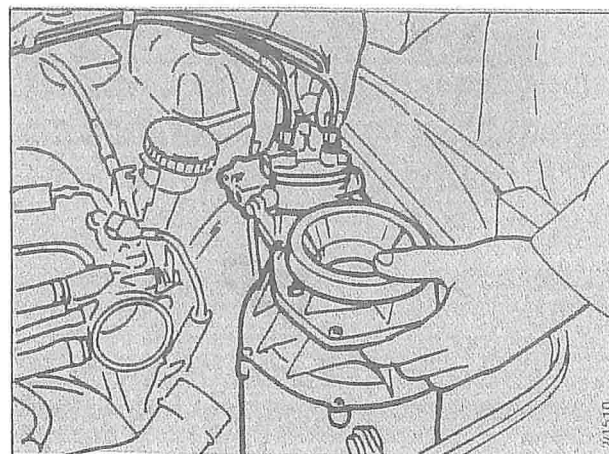

- 22 Disconnect the throttle cable and electric cable.
- 23 Disconnect the vacuum hoses for the brake servo from the intake manifold and the vacuum tank system from the throttle housing.

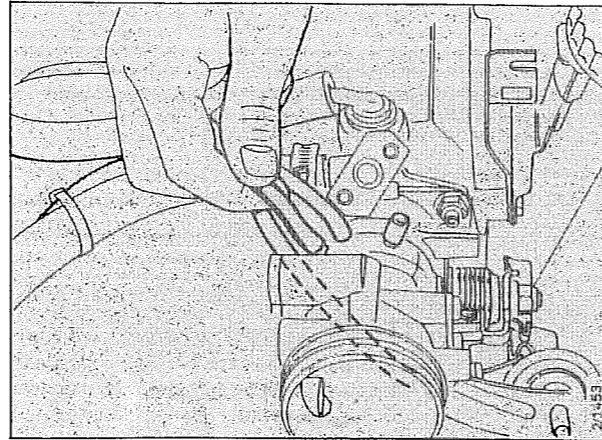
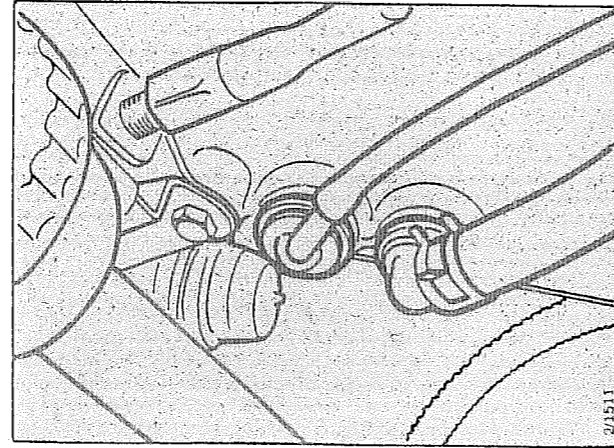

- 24 Release the oil dipstick pipe.

- 25 Cut away the straps and release the cable harness on the left-hand side of the engine.

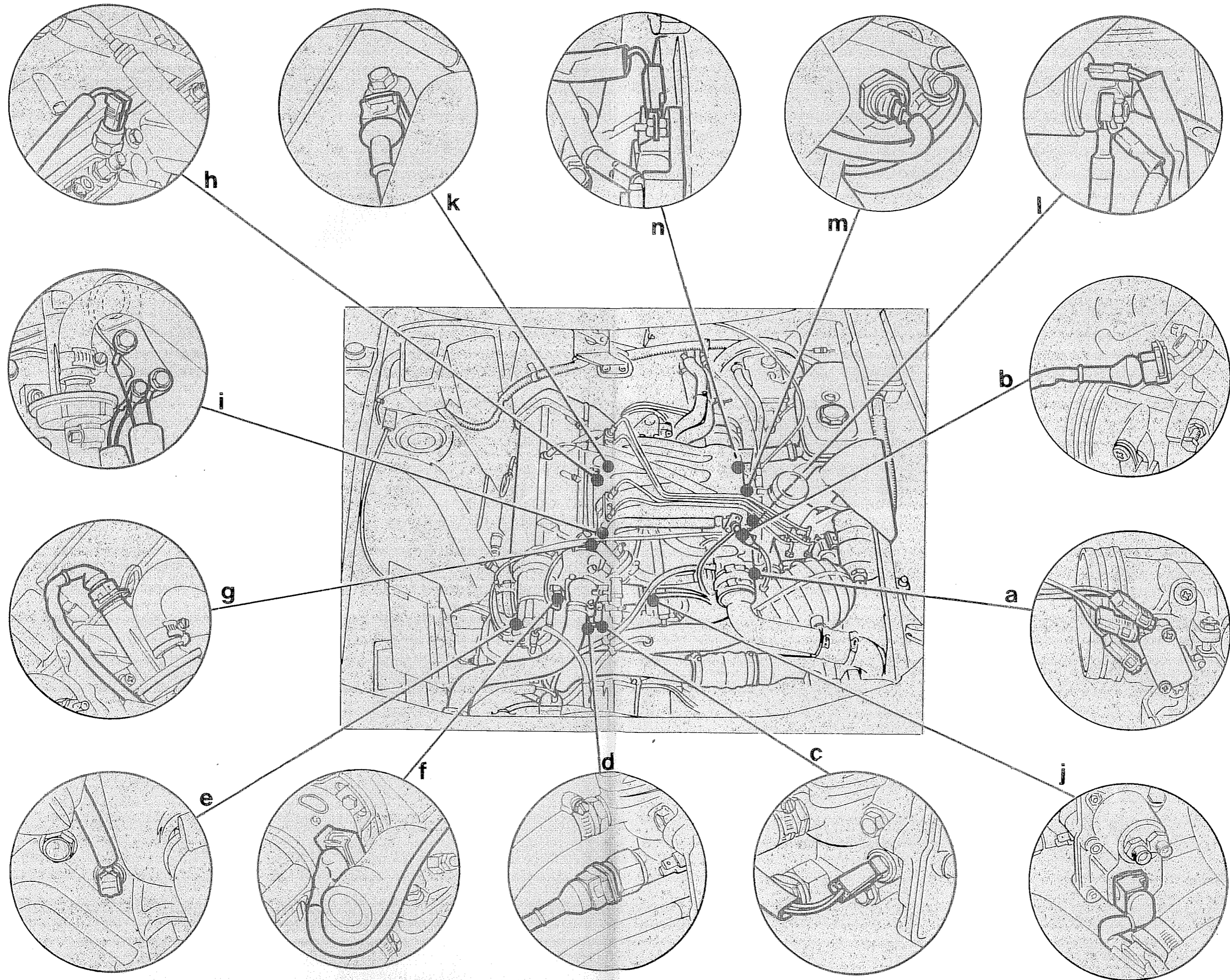

Removing the cable harness from the B201 engine

Then disconnect the wiring at the following points:

- a full-load enrichment switch

Note

Note the locations of the cables and mark them if in doubt.

- b cold-starting valve
- c temperature switch, Lambda
- d temperature time switch
- e temperature sensor
- f Hall sensor
- g auxiliary air valve
- h temperature switch
- i earthing points at the lifting lug

Note

Note the locations of the cables.

- j control pressure regulator
- k knock sensor
- l starter motor (at the same time, disconnect the positive cable)
- m oil pressure sensor
- n alternator

Place the cable harness on the radiator cross-member.

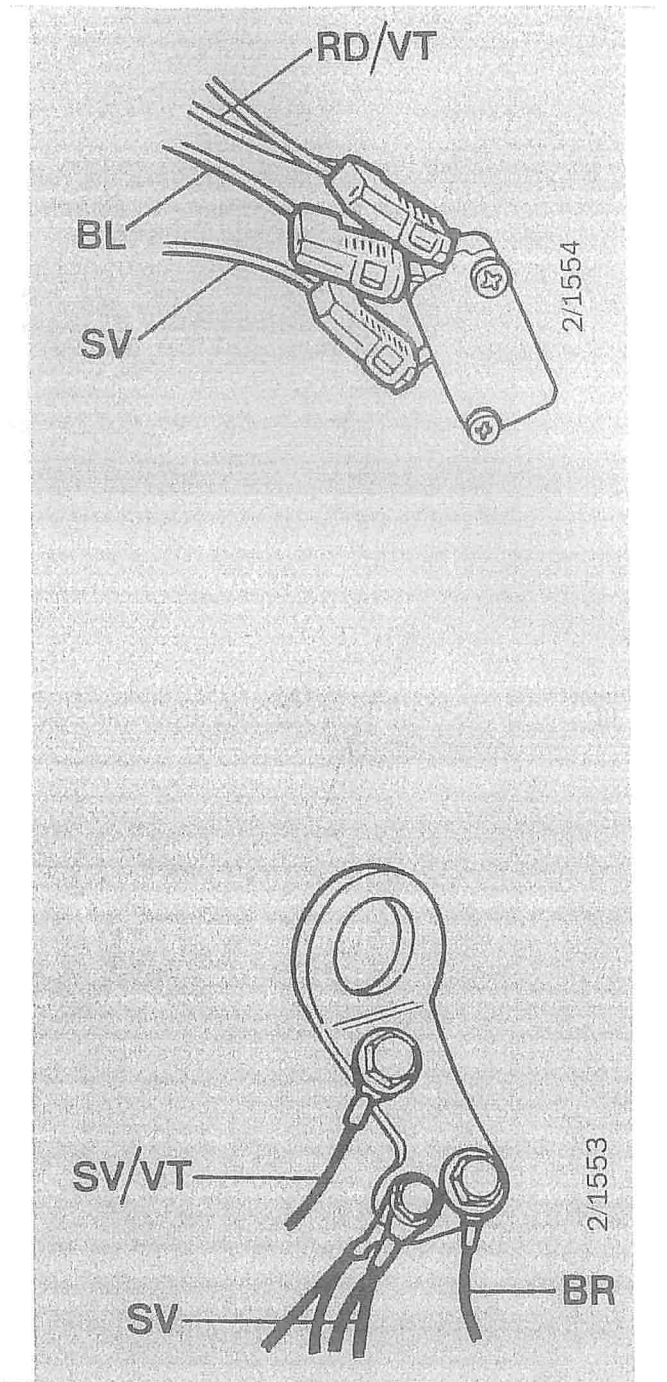

- 26 Disconnect the coolant pipes to the turbocharger from the mounting on the timing gear cover and remove the earth cable.
- 27 Disconnect the hydraulic hose from the slave cylinder. Use tool 83 93 571. Plug the hose.

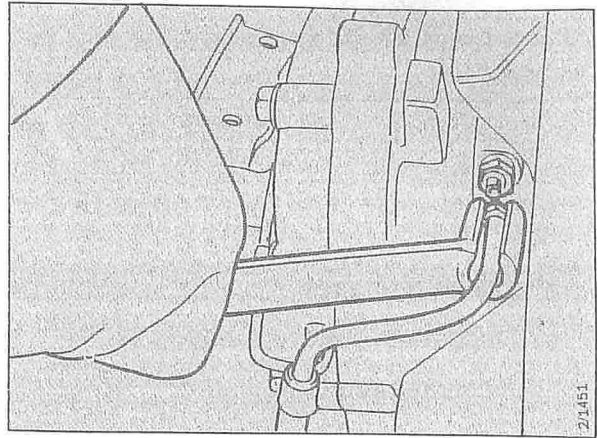

- 28 Disconnect the coolant hose from the bottom of the radiator.

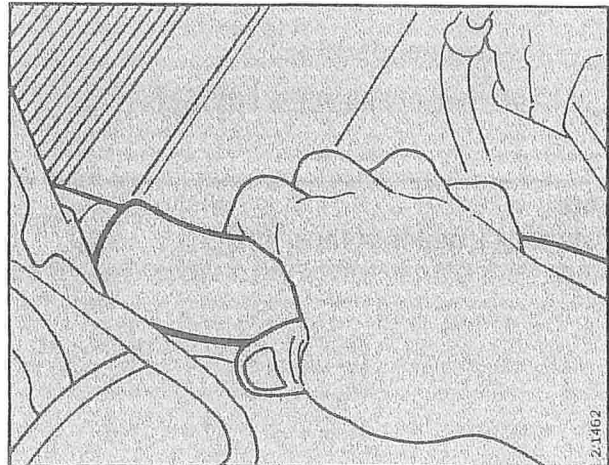

On a car with AC, remove the extra radiator fan.

- 29 Release the positive cable from its clips on the engine and place it on the battery bracket.
- 30 Release the ignition coil and disconnect the lead from the distributor cap. Place the coil on the radiator cross-member.

- 31 Separate the Lamda sensor cable at the connector over the right-hand wheel housing. Release the clip at the wheel housing and lay the cable on the engine.

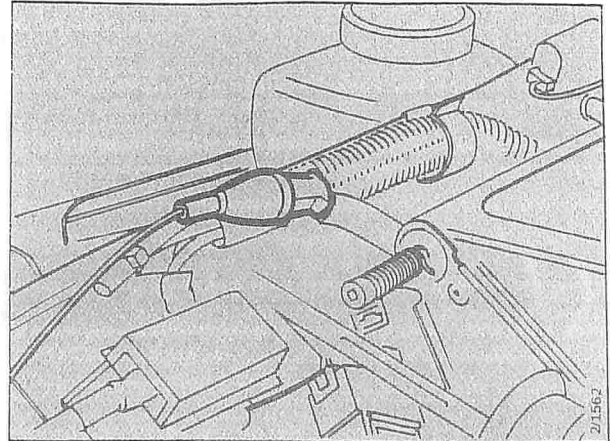

- 32 On a car with AC:

Remove the four AC compressor bolts and place the compressor on the heat exchanger.

- 33 Remove all engine mounting bolts.

In the left-hand engine mounting, the through bolt is fitted with a spacer sleeve.

On cars to US specification, also remove the movement limiters from the front and right-hand engine mountings.

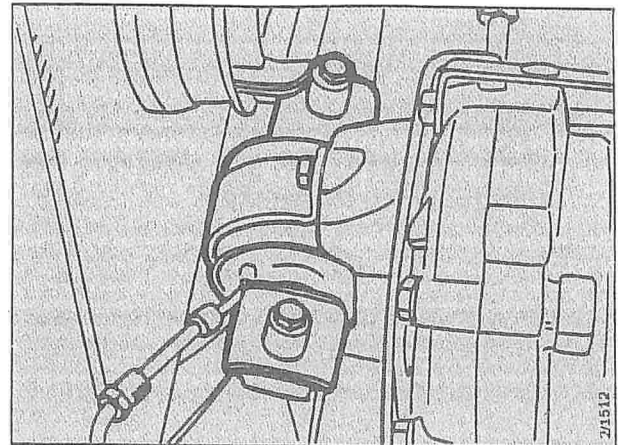

Front engine mounting

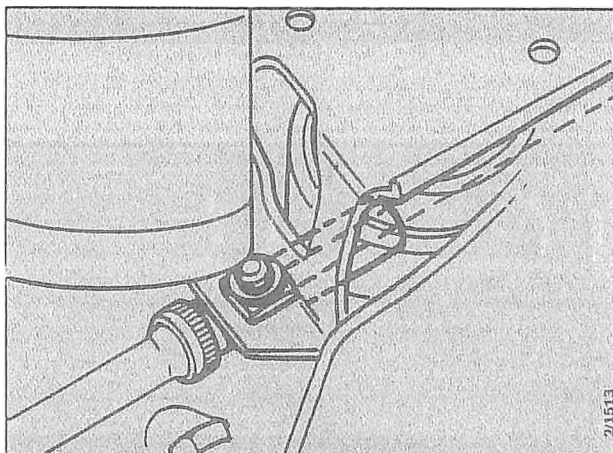

Left-hand engine mounting

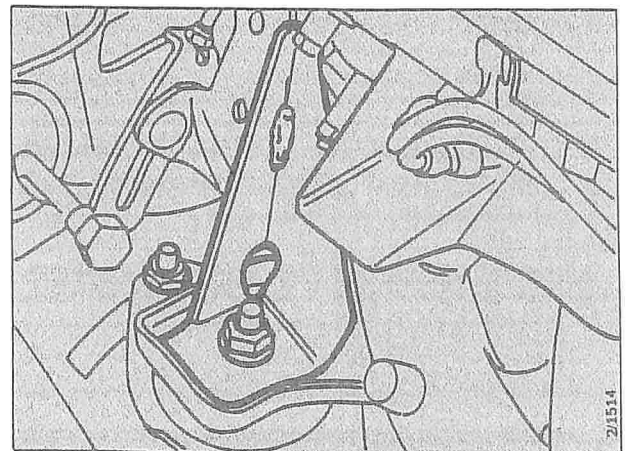

Right-hand engine mounting

Note

Cars with air conditioner have a notch in the AC bracket for a lifting hook. If the bracket has been removed, fit a separate lifting lug 93 13 222 instead to the water pump cover. Use the existing bolts.

- 34 Secure the lifting yoke to the power unit and lift the power unit so that the left-hand inner universal joint can be separated.
- 35 Disconnect the steering servo pump return line.

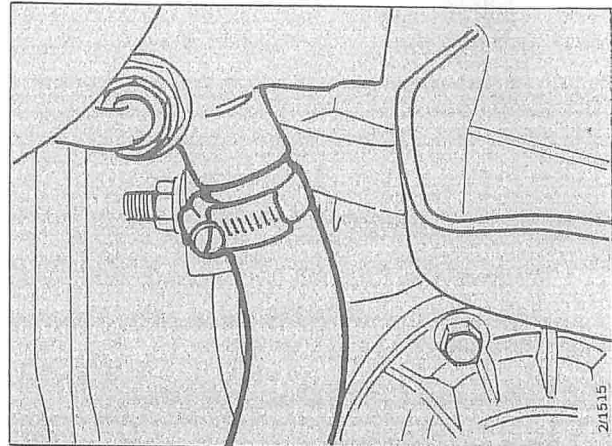

- 36 Remove the oil pressure sensor and disconnect the hoses for the air-cooled oil cooler from the oil filter housing.

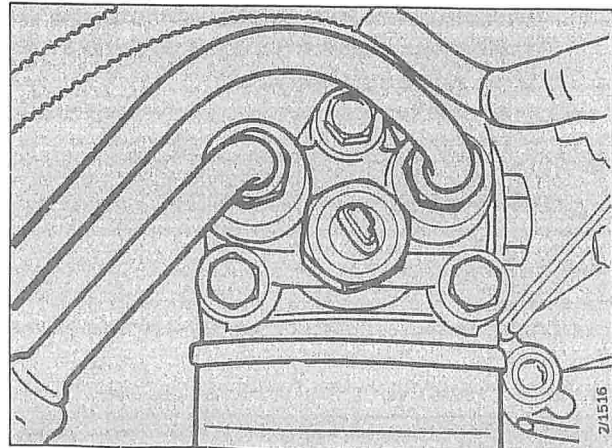

- 37 Lift the power unit out of the car. Take great care to avoid damage, above all to the radiator and solenoid valve.

Fit protective caps to the universal joint drivers.

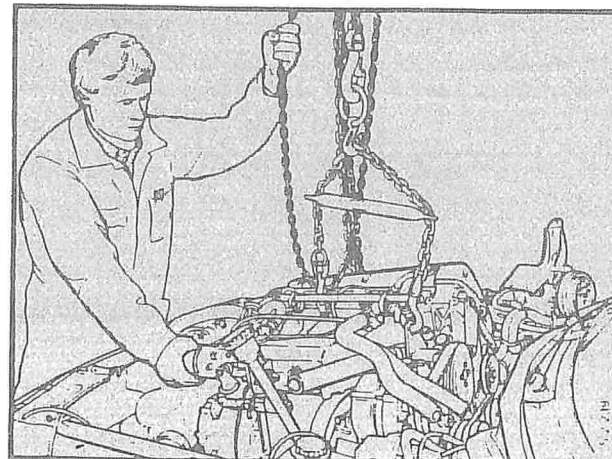

To fit the power unit

- 1 Check that the universal joints are packed with grease.
Fit the drain plugs for the cooling system.
- 2 Suspend the power unit from the lifting yoke so that the front engine mounting is somewhat lower than the rear mountings.

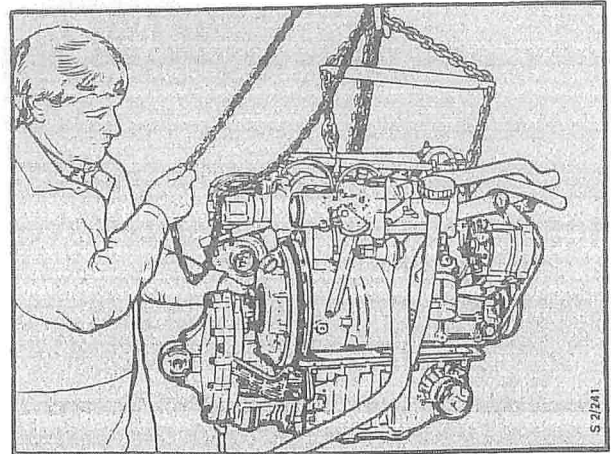

- 3 Lower the power unit into the engine compartment down to a height at which the oil cooler hoses, the oil pressure sensor and the steering servo pump return hose can be connected.
- 4 Align the power unit in the following order:
 - front engine mounting
 - left-hand inner universal joint
 - right-hand inner universal joint

Then lower the power unit onto the rear engine mountings and fit the bolts. Don't forget the spacer sleeve for the left-hand mounting.

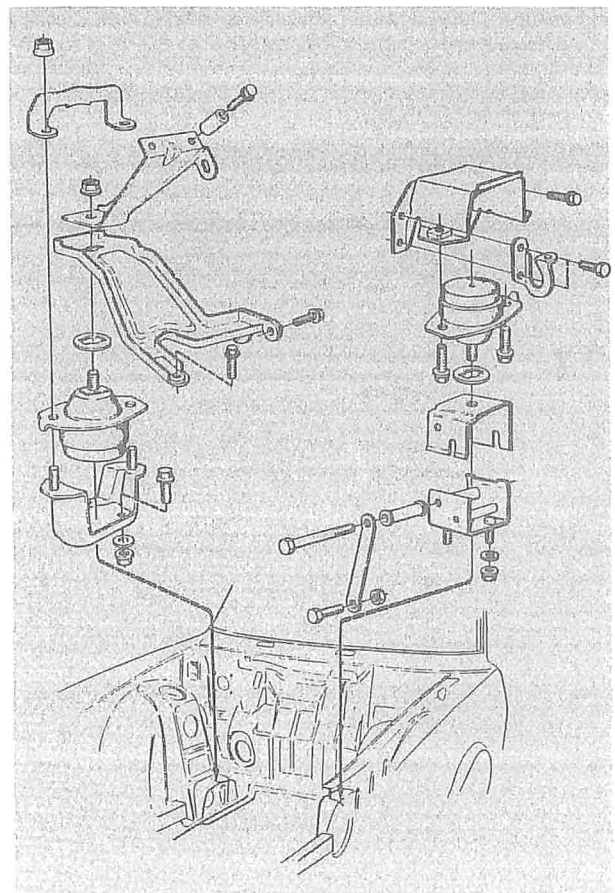

- 5 Unhook the lifting yoke hooks and, if applicable, remove the lifting lug from the water pump (car with AC).
- 6 If the car is equipped with an AC:
 - Fit the AC compressor.
 - Fit the drive belt and tension it.

431-16 Removing and fitting

- 7 Connect the coupling on the delivery side of the steering servo pump.

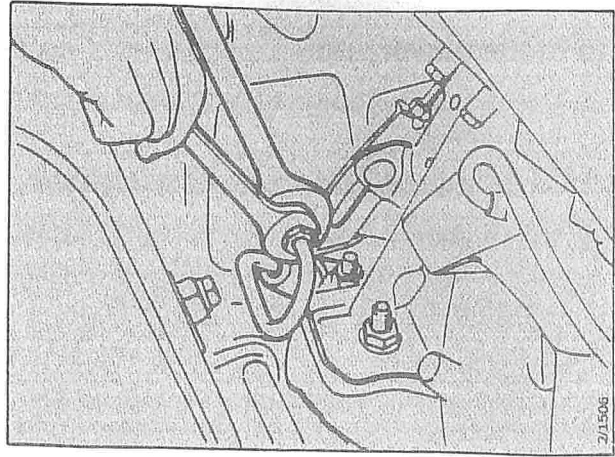

- 8 Secure the exhaust pipe loosely to the exhaust manifold.
- 9 Lift the car to a suitable height and fit the ball joint to the bottom wishbone and anti-roll bar.

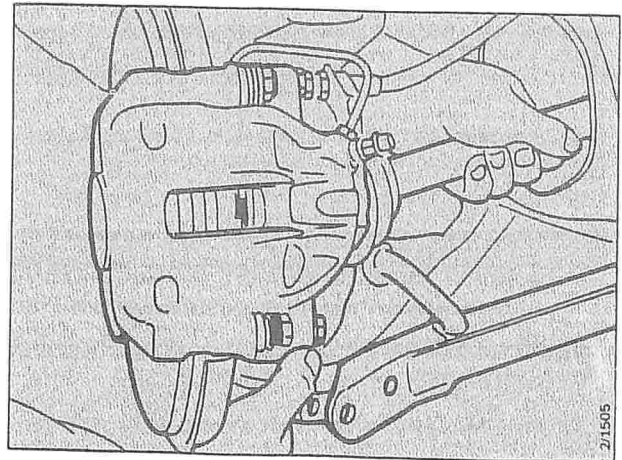

Refit the wheel.

- 10 Lift the car and fit the following:
 - a The rubber gaiters and clips to the universal joints.

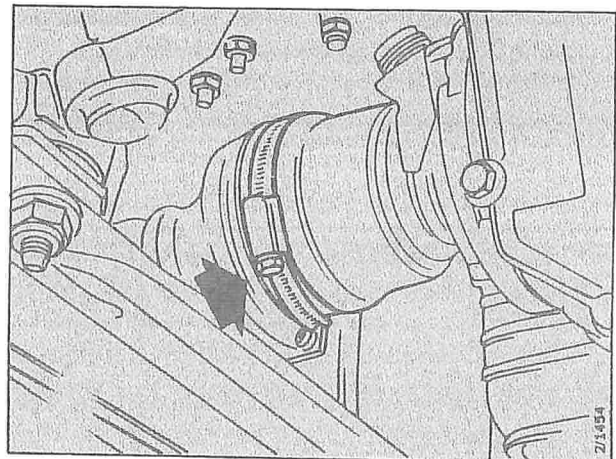

- b The bolts for the exhaust pipe bracket to the gearcase.

The exhaust pipe clamp may have to be slackened slightly to enable the bracket to be bolted to the gearcase.

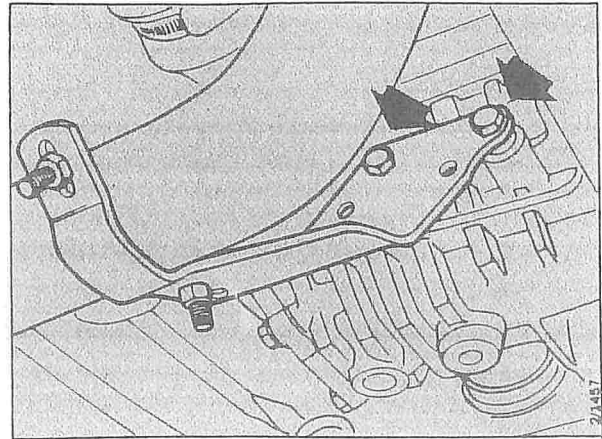

- c Speedometer cable.

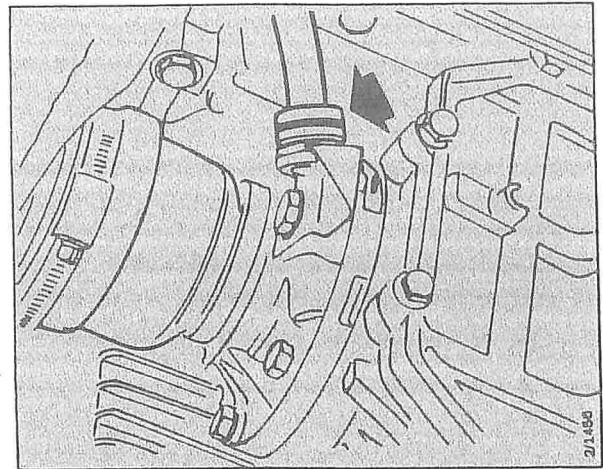

- d Selector rod taper pin.

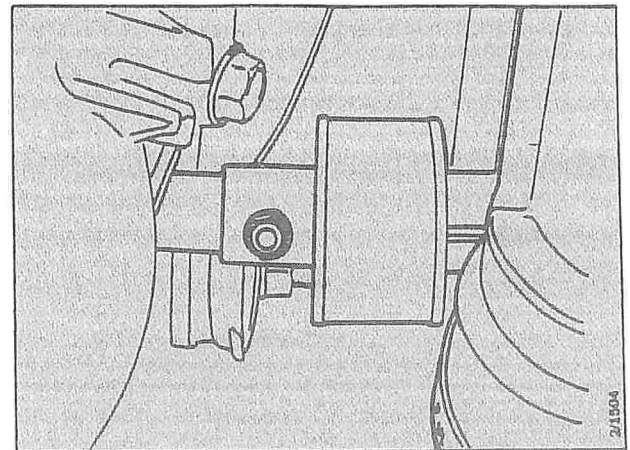

431-18 Removing and fitting

- 11 Lower the car to a suitable working height and:
 - Connect the earth cable to the timing gear cover.
 - On cars with water-cooled turbocharger, connect the coolant pipe to the turbocharger.
 - Run the positive cable into place and fit the clips.
- 12 Remove tool 83 93 209 under the right-hand upper wishbone and tighten the wheel nuts.

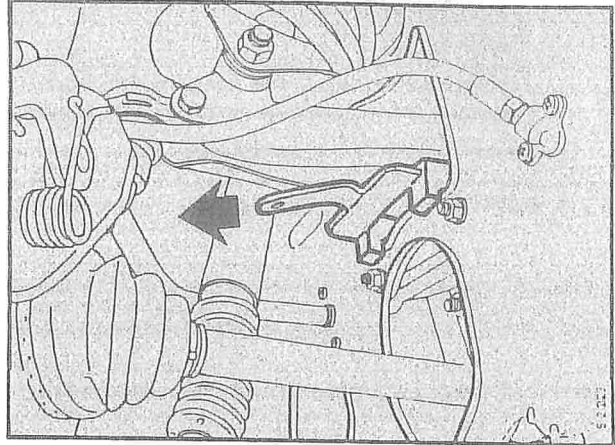

**Tightening torque for the wheel nuts:
105 - 125 Nm (77 - 92 lbf ft)**

- 13 Tighten the exhaust pipe flange bolts.

- 14 Connect the Lambda sensor connector. Fit the clip to the wheel housing and secure the cable.

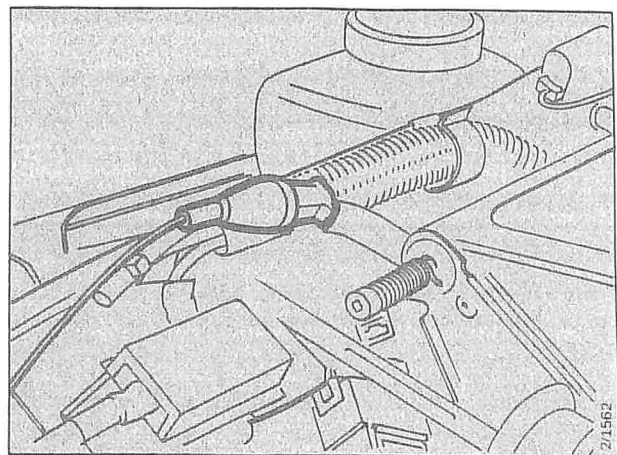

- 15 Connect the radiator hose to the bottom of the radiator and connect the hydraulic line to the clutch slave cylinder.

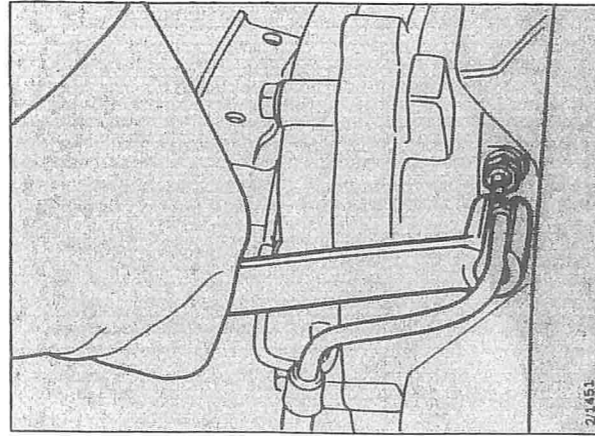

Bleed the clutch (see section 411).

- 16 Run the cable harness into place and make the connections to the following terminals in the order listed:

a full-load enrichment switch

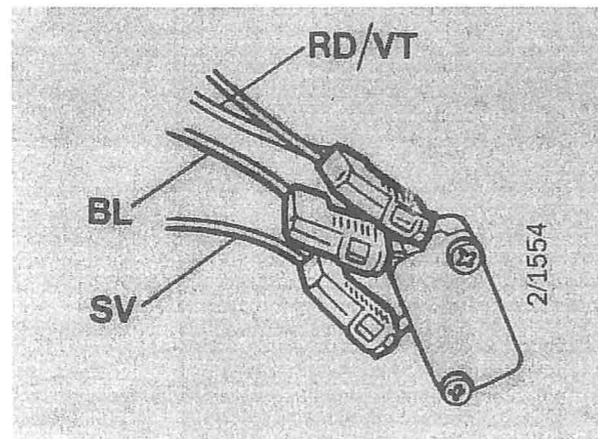

Note

Make sure that the cables are connected to the correct terminals on the full-load enrichment switch and to the earthing points on the lifting lug.

b cold-starting valve

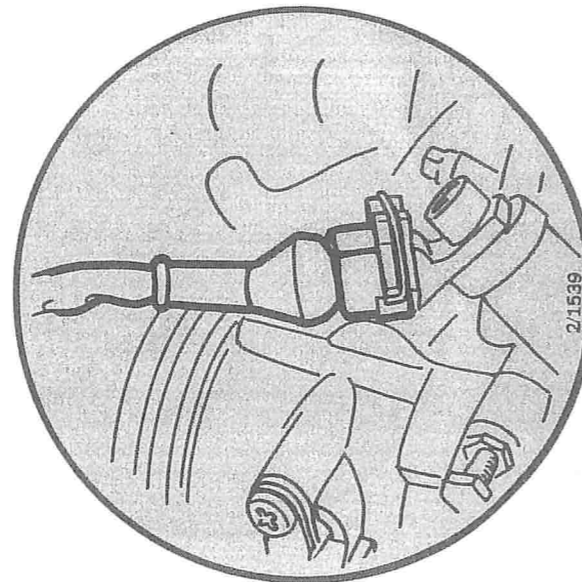

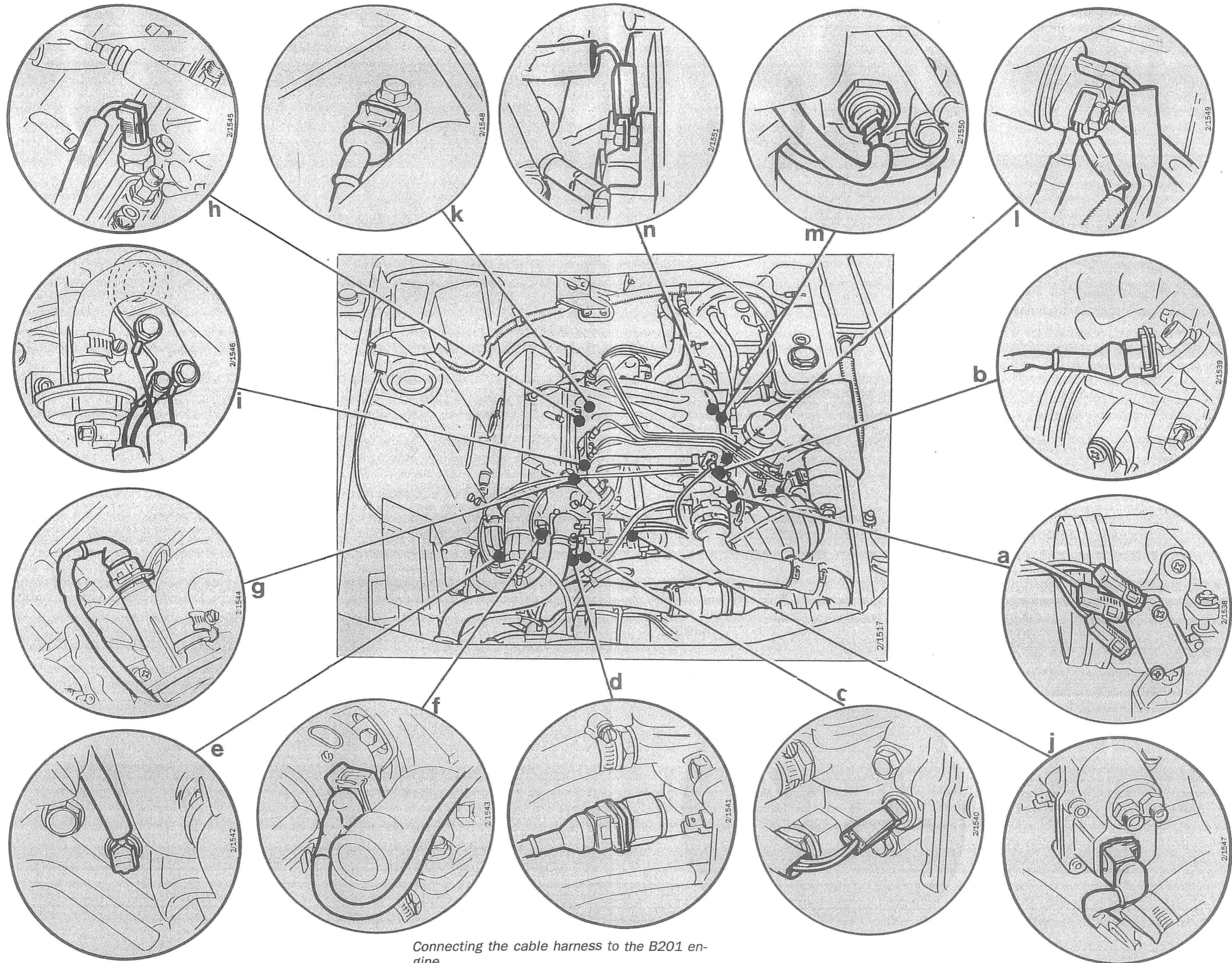

Connecting the cable harness to the B201 engine

- c temperature switch, Lambda
- d temperature time switch
- e temperature sensor
- f Hall sensor
- g auxiliary air valve
- h temperature switch
- i earthing points on the lifting lug

Note the locations of the cables.

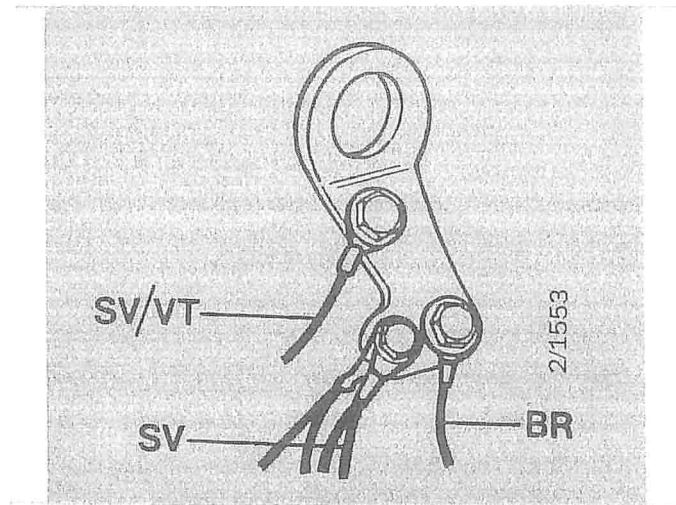

- j control pressure regulator
- k knock sensor
- l starter motor

At the same time, connect the positive cable.

- m oil pressure sensor
- n alternator

Secure the cable harness with straps to the positive cable and to the mounting points on the flywheel housing.

- 17 Connect the vacuum hoses for the brake servo to the intake manifold and the vacuum tank system to the throttle housing.

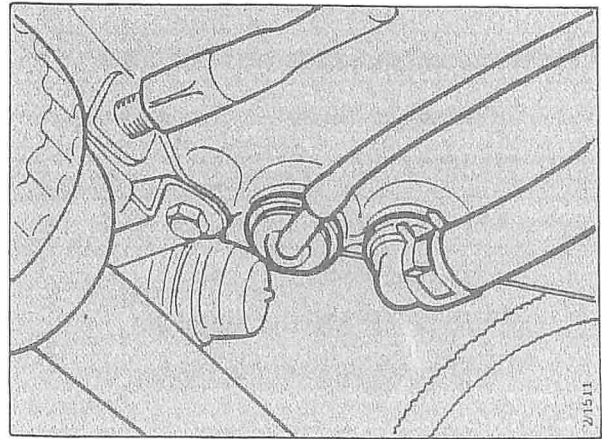

- 18 Connect the throttle cable and the electric cable.

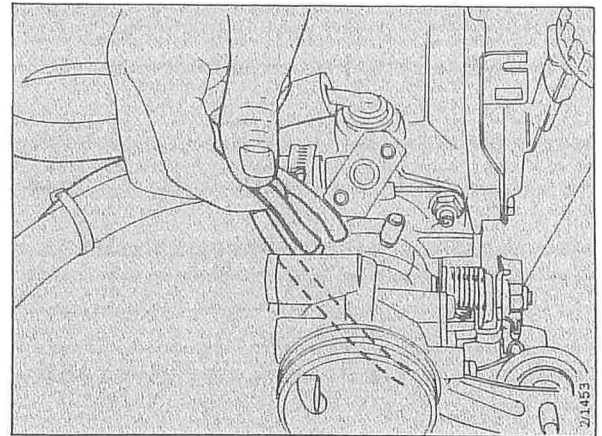

- 19 Place the fuel distributor with air cleaner in position and clip them into place.

Make the connections to the fuel distributor in the order listed below:

- a Connect the earth cable to the fuel distributor.

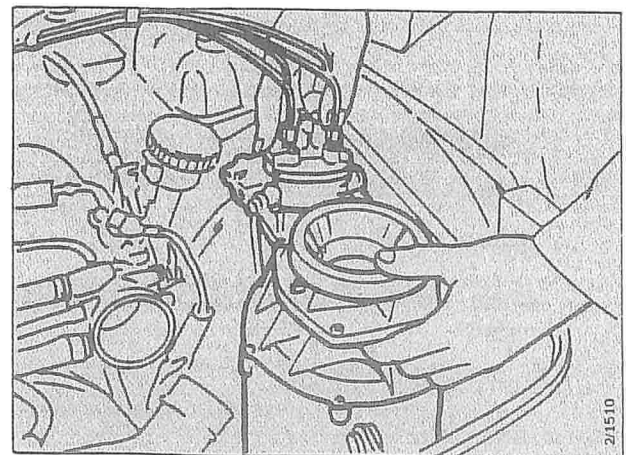

- b Connect the following to the fuel distributor:

- hose from the fuel filter (1)
- hose from the fuel-boosting valve (2)
- fuel return hose (3)
- hose from the control pressure regulator to the fuel-boosting valve (4)

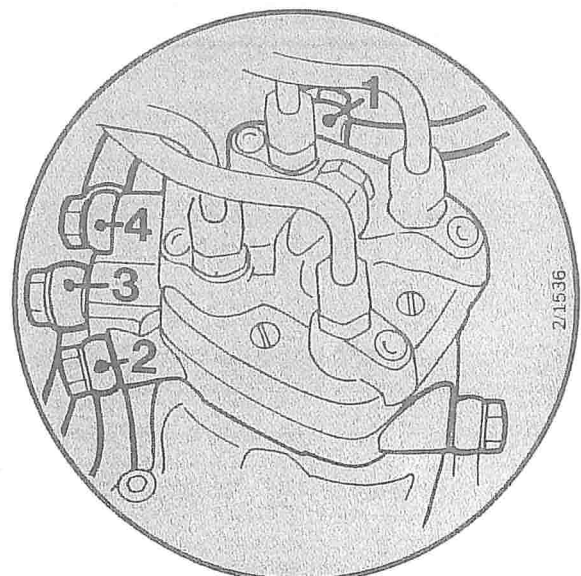



c Connect the fuel lines to the control pressure regulator.

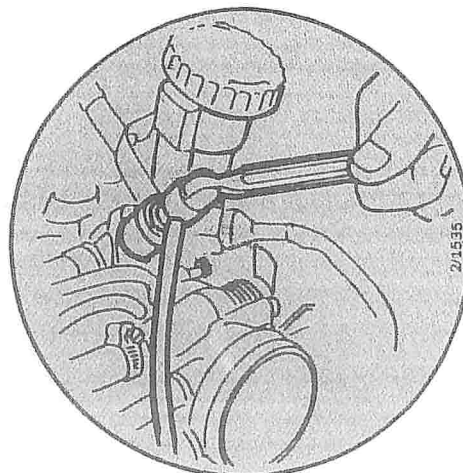

d Connect the fuel hose to the cold-starting valve.

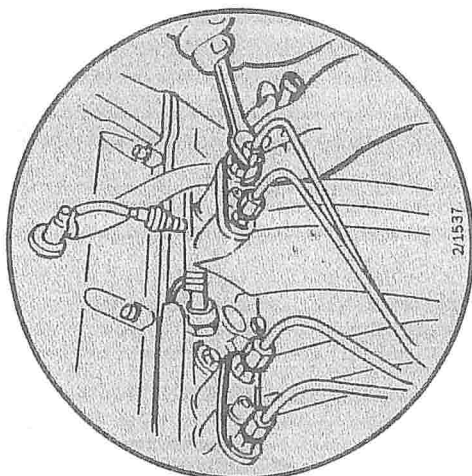

e Connect the fuel lines to all injection valves.

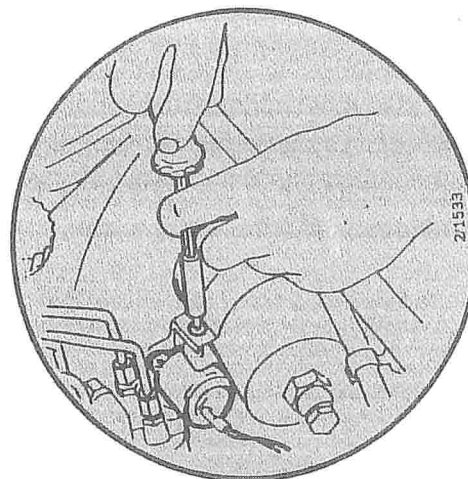

f Fit the pressure switch and connect the vacuum hose.

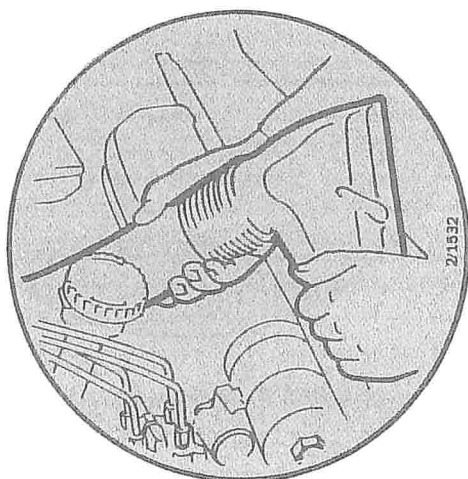

g Fit the air cleaner "snorkel".

- 20 Fit the pipe for the oil dipstick.
- 21 Remove the protective cap from the turbocharger inlet pipe and fit the intercooler together with the air pipe.

Fit the cover over the intercooler.

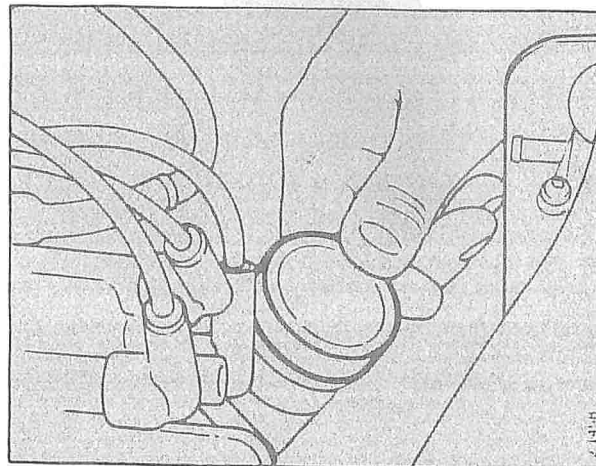

- 22 Fit the rubber bellows to the fuel distributor.
- 23 Fit the turbocharger delivery pipe between the intercooler and the throttle housing.
- 24 Connect the coolant hoses to:

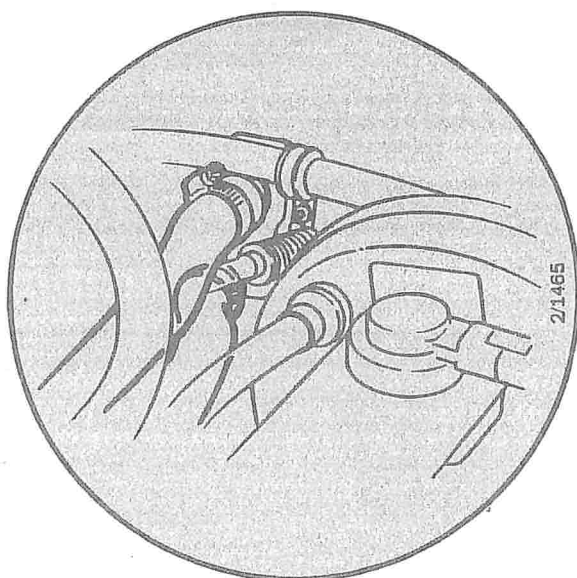

a heat exchanger valve

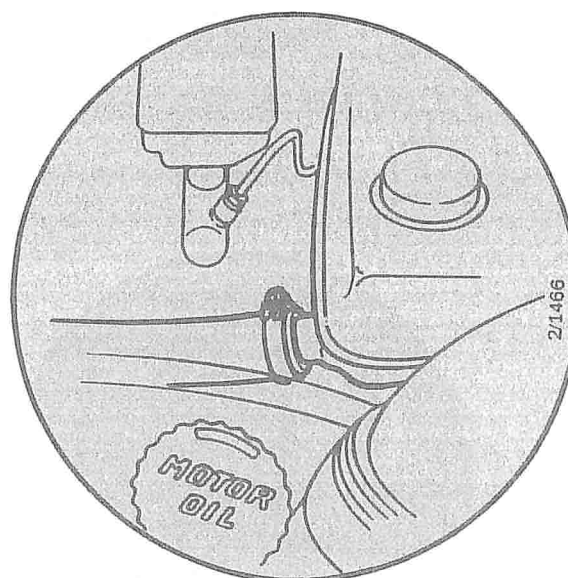

b expansion tank

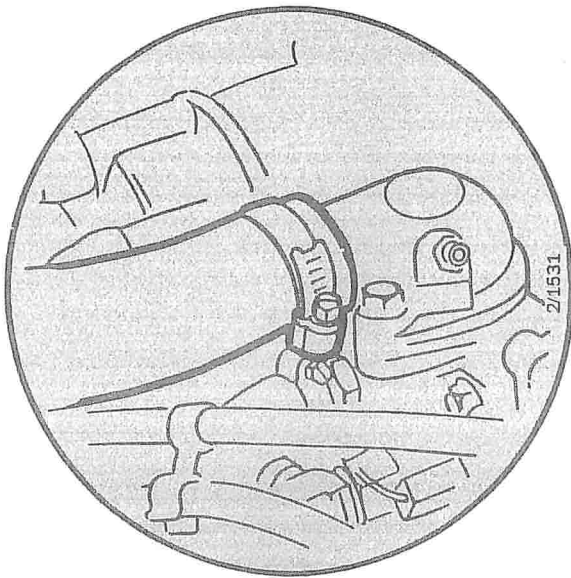

c thermostat housing

- 25 Connect the signal hoses to the solenoid valve.

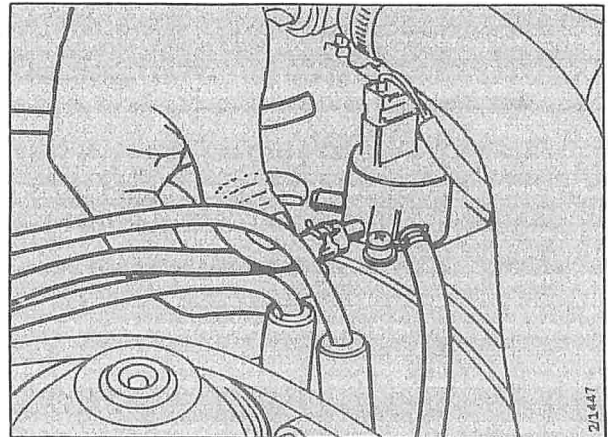

- 26 Fit the ignition coil and connect the lead to the distributor cap.
- 27 Fill the steering servo reservoir with Texaco Power Steering Fluid 4634 or equivalent.
- 28 Fill the cooling system with coolant and pressure test it.
- 29 Fit the battery and connect the cables.
- 30 Fit the bonnet and connect the hose for the windscreen washers.
- 31 Start the engine, check the various functions and check that none of the hoses are leaking.

To remove and fit (car with B202 engine)

The procedure described below applies to a car with the Turbo engine with intercooler, AC, catalytic converter and water-cooled turbocharger (1988 model).

For earlier models and other engine versions, the method described here must be adjusted in each individual case.

To remove

- 1 Remove the bonnet by releasing the links at each hinge, and disconnect the hose for the washers.

Place the bonnet securely, such as by leaning it against a wall, to prevent it from being damaged.

- 2 Fit tool 83 93 209 between the right-hand upper wishbone and the body. Turn the steering wheel to the right-hand lock and fit the tool from the wheel housing side.

- 3 Disconnect the cables from the battery and remove the battery.

- 4 Remove the exhaust pipe flange bolts.

- 5 Back off the right-hand front wheel nuts.

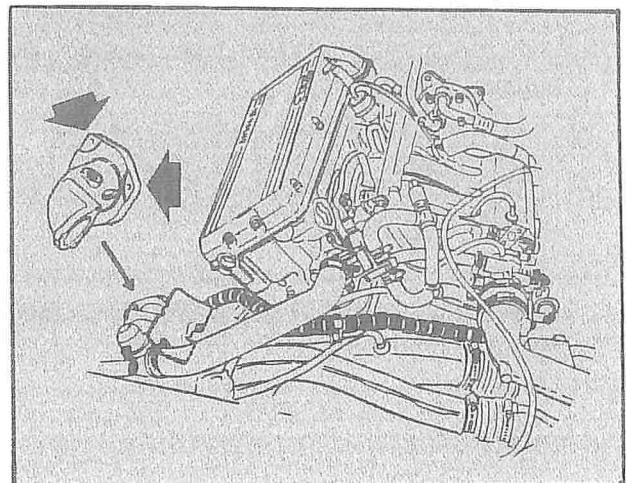
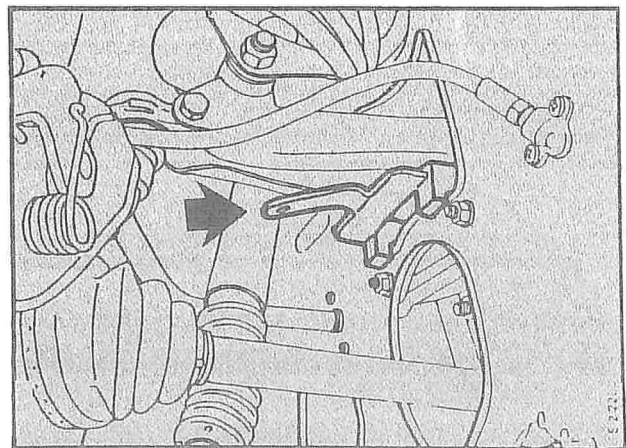
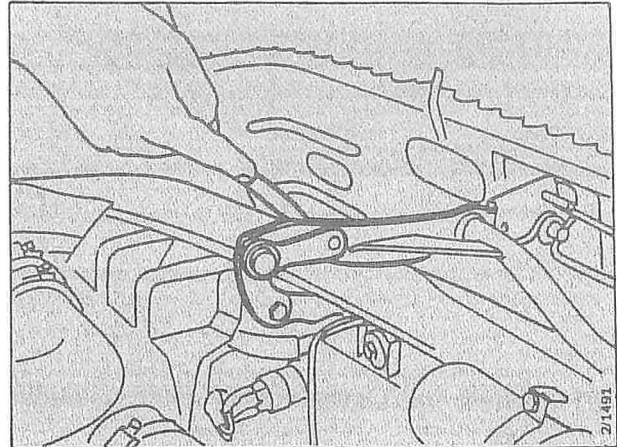

- 6 Drain the oil from the steering servo pump reservoir.
- 7 Lift the car.
- 8 From the underside of the car:
 - a Remove the nut and carefully tap out the taper pin from the selector rod. Use tool 87 91 394 if necessary.

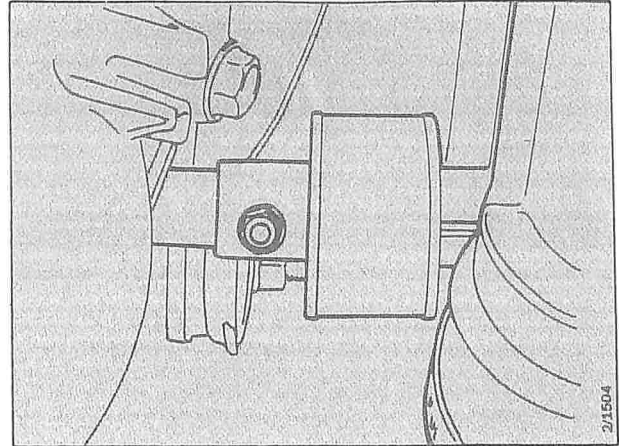

- b Disconnect the speedometer cable.

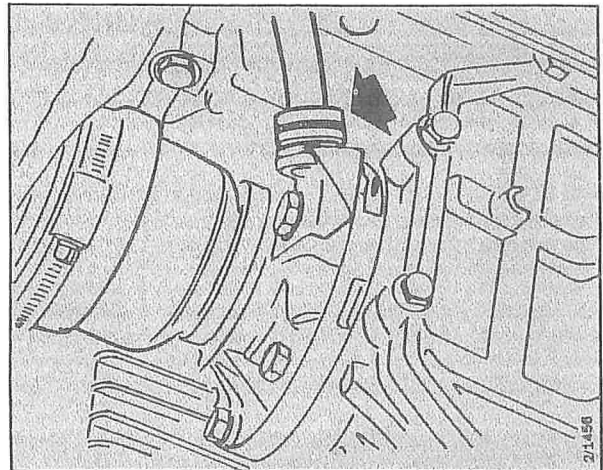

- c Remove the bolts for the exhaust pipe support bracket.

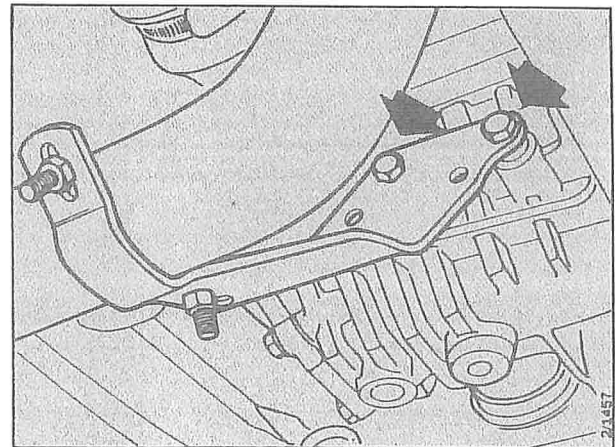

- d Release the clips on the inner universal joints and remove the gaiters from the universal joint drivers.

431-28 Removing and fitting

- 9 Lower the car to a suitable working height.
- 10 Remove the right-hand front wheel.
- 11 Release the ball joint from the lower wishbone and the anti-roll bar.

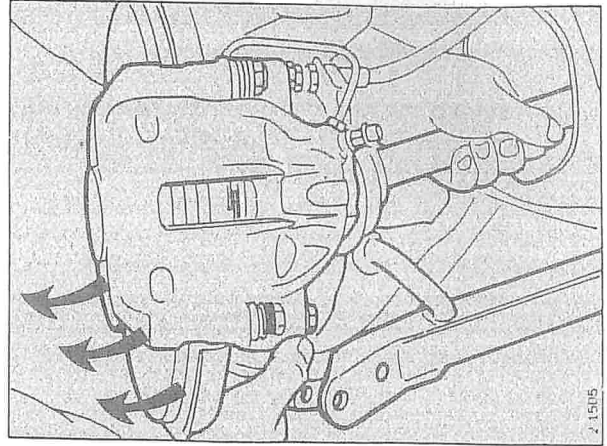

- 12 Separate the universal joint on the right-hand side, move the drive shaft forward of the universal joint driver and support it in this position.

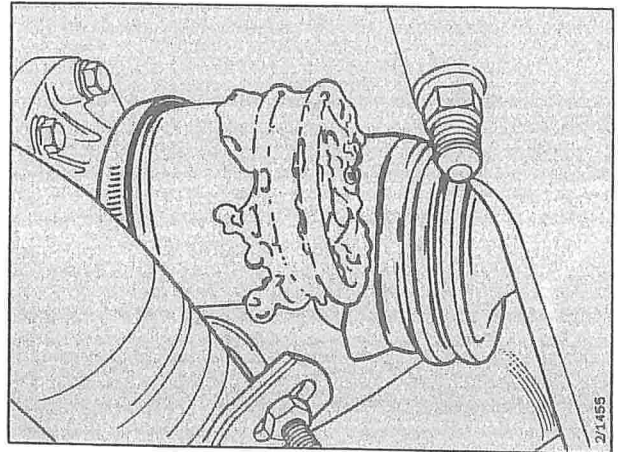

- 13 Release the coupling on the delivery side of the steering servo pump. Plug the pipe and avoid spilling oil on the engine mounting.

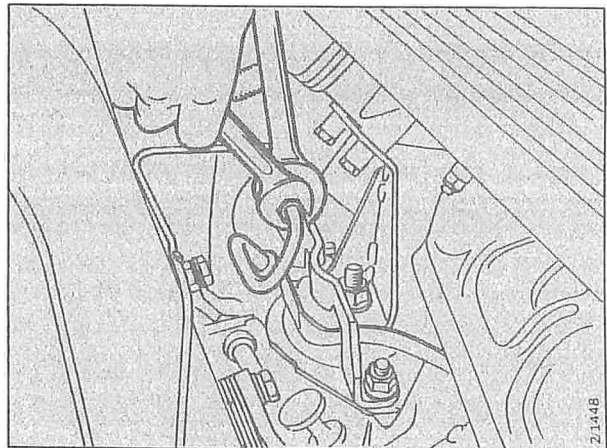

- 14 Screw out the tensioner and remove the AC compressor drive belt.
- 15 Remove the drain plugs from the underside of the engine block and radiator, and drain the coolant. Remove the oil filler pipe.

16 Disconnect the coolant hoses at:

- a Heat exchanger valve. Note the way they are connected.
- b Expansion tank
- c Thermostat housing

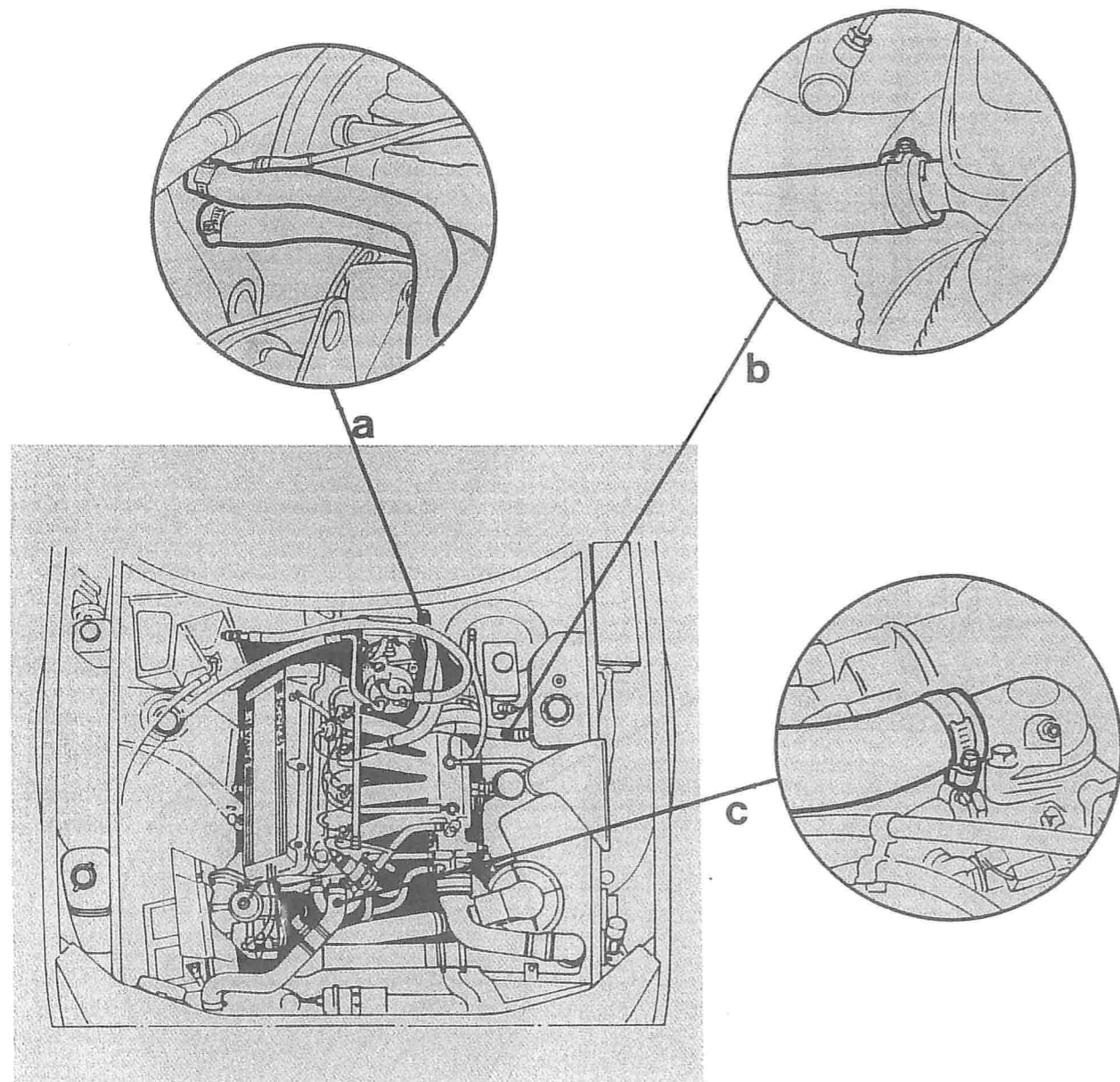

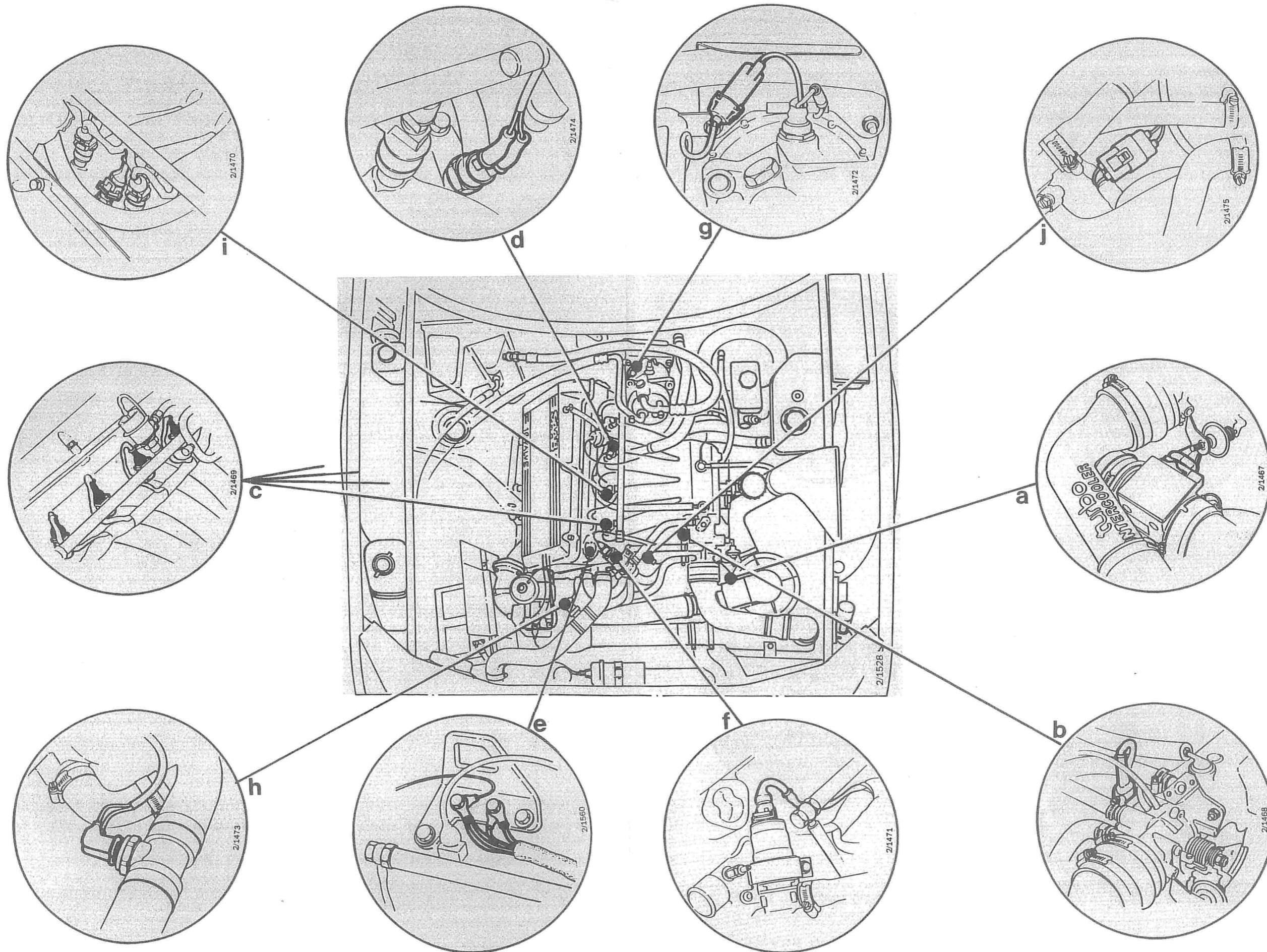

Removing the cable harness with the wiring of the LH system from the B202 engine

- 17 Disconnect the cable harness of the LH system at:
- a Air mass meter
 - b Throttle switch
 - c Injection valves
 - d Temperature sensor
 - e Earthing points at the lifting lug
 - f AIC valve

Note

If necessary, use a small screwdriver to release the locking clips on the connectors when disconnecting them.

- 18 Disconnect the other connections of the cable harness at:
- g Temperature switch of the AC compressor
 - h Temperature switch for the AC fan
 - i AC temperature sensor

- 19 Withdraw the disconnected cables of the cable harness, withdraw the harness from the engine compartment and place it on the AC system heat exchanger.
- 20 Remove the turbocharger delivery pipe.
- 21 Remove the air mass meter together with the bellows.
- 22 Remove the air cleaner together with the "snorkel".

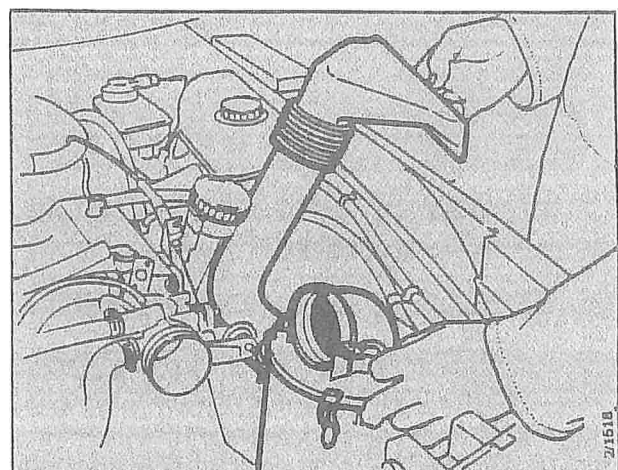

431-32 Removing and fitting

- 23 Remove the intercooler together with the air pipe.

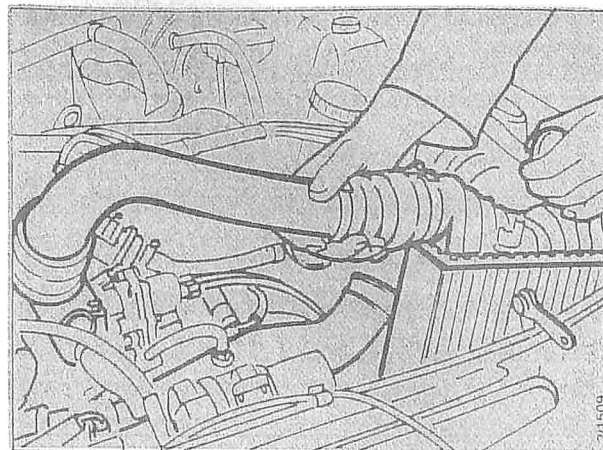

- Fit a blanking-off cap to the turbocharger suction pipe.

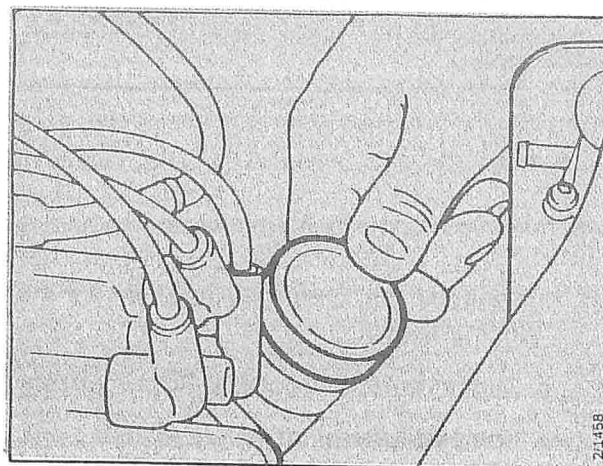

- 24 Remove the intercooler side plate.

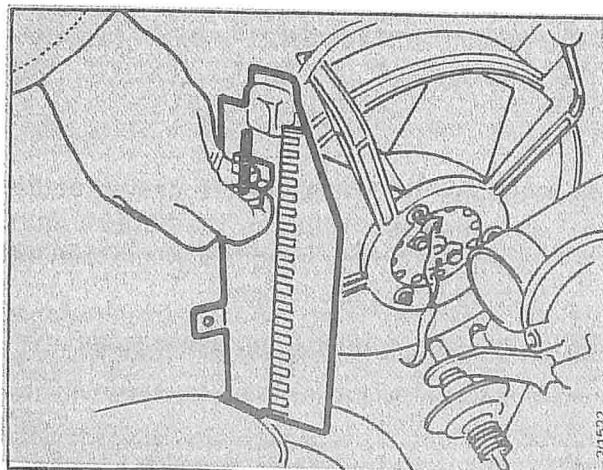

- 25 Remove the ignition coil.
26 Remove the radiator fan for the AC system.

27 Disconnect the coolant hose from the bottom of the radiator.

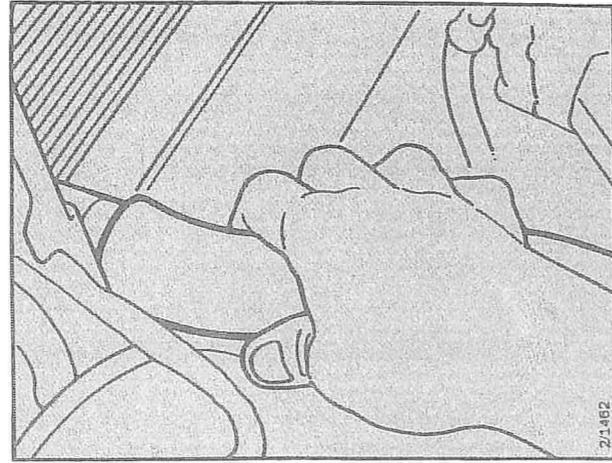

28 Disconnect the signal hoses from the solenoid valve.

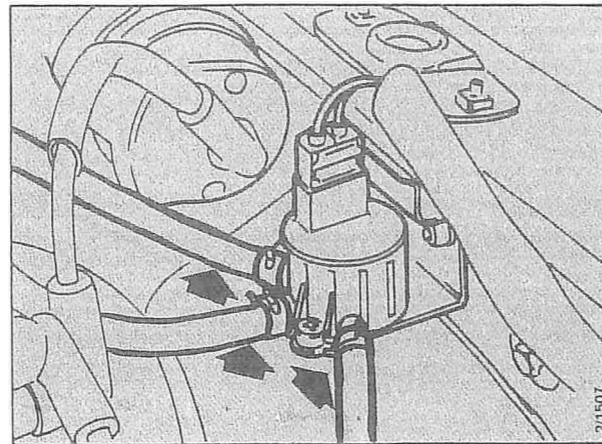

29 Disconnect the throttle cable and electric cable.

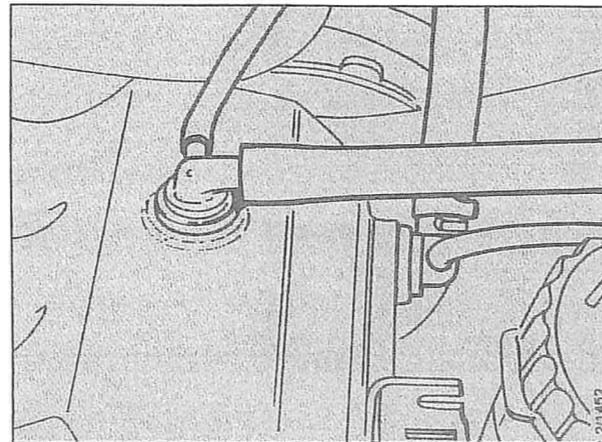

30 Disconnect the vacuum hoses for the brake servo from the intake manifold and the vacuum tank system from the throttle housing.

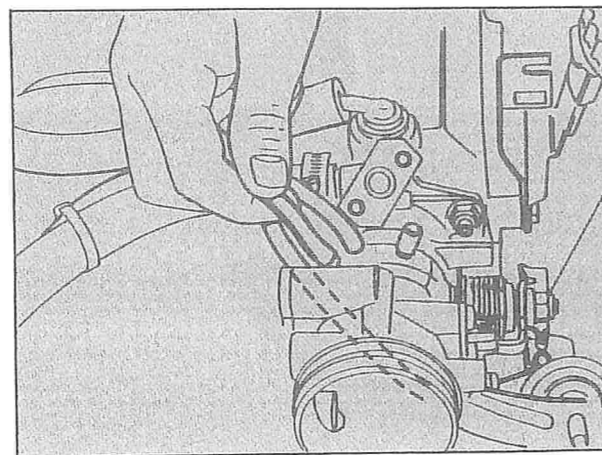

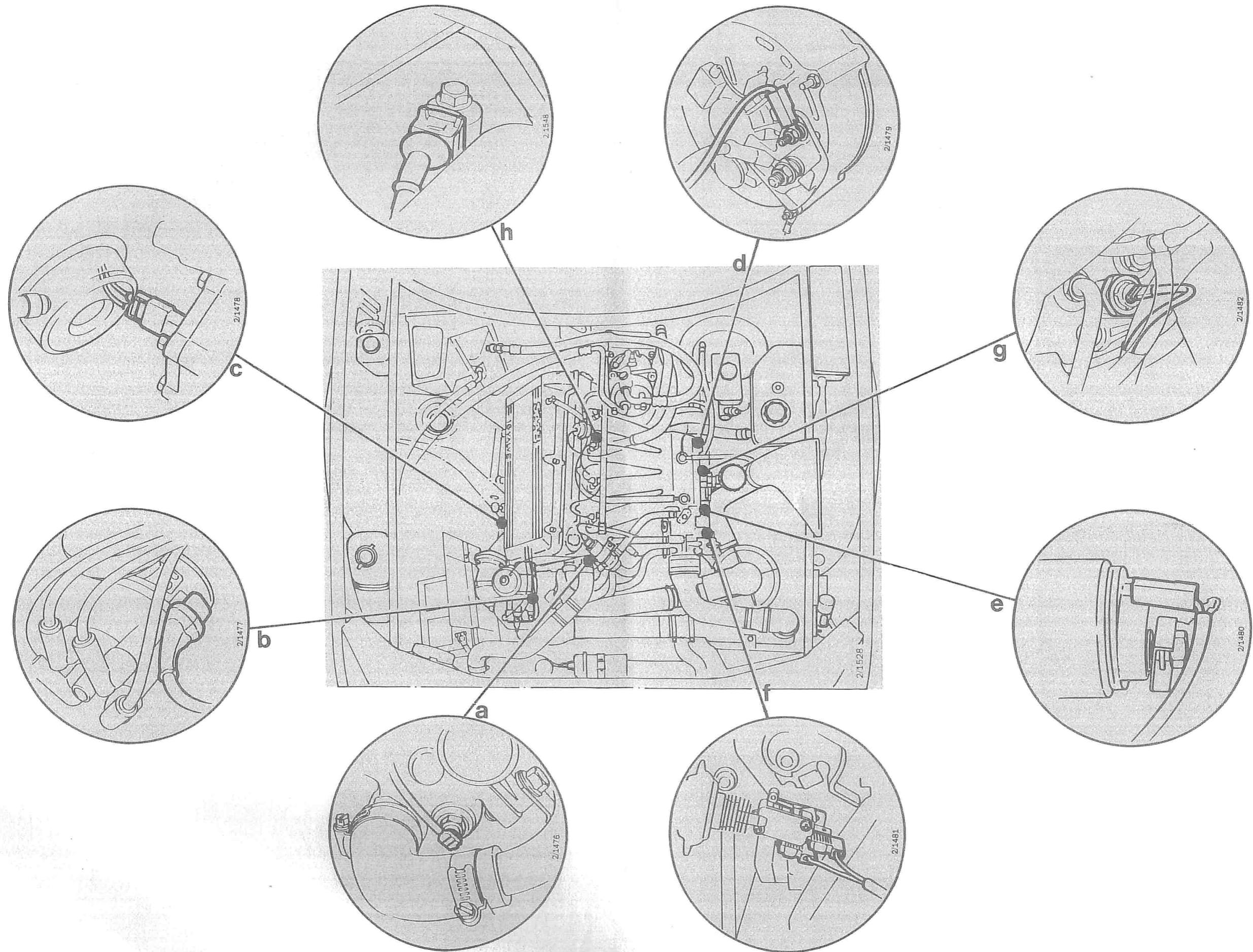

Removing the left-hand cable harness from the B202 engine.

- 31 Cut off the straps and release the cable harness for the starter motor, alternator, temperature sensor, etc. on the left-hand side of the engine.
- 32 Disconnect the cable harness connections at the following points:
 - a engine temperature sensor
 - b Hall sensor
 - c gear shift contact
 - d alternator
 - e starter motor
 - f throttle switch (AC)
 - g oil pressure sensor
 - h knock sensor

Place the cable harness on the radiator cross-member.

- 33 Release the clips securing the positive cable to the engine. Disconnect the cable from the starter motor and place the cable on the battery bracket.
- 34 Release the earth cable from the mounting on the timing gear cover.
- 35 Separate the Lambda sensor cables at the connectors over the right-hand wheel housing. Lay the cables on the engine.

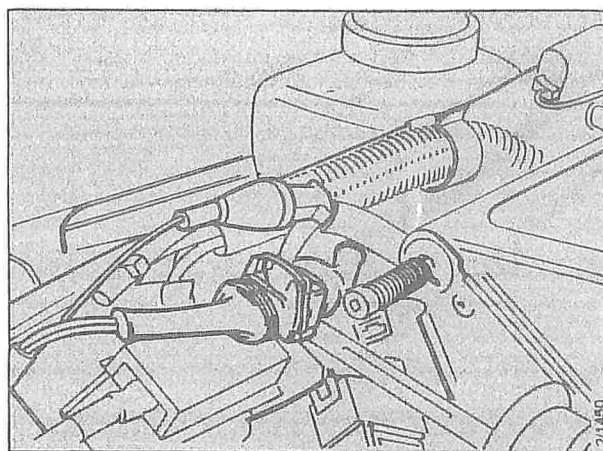

431-36 Removing and fitting

- 36 Disconnect the hydraulic hose from the slave cylinder. Use tool 83 93 571. Plug the hose.

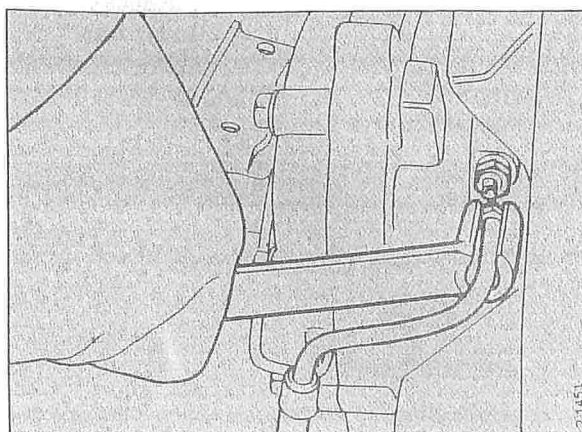

- 37 Disconnect the fuel hoses at the connections to the fuel pipe or to the fuel pressure regulator.

- 38 Remove the four AC compressor bolts and place the compressor on the heat exchanger.

- 39 Remove all engine mounting bolts.

The through bolt in the left-hand engine mounting is fitted with a spacer sleeve. On cars to US specification, also remove the movement limiters from the front and right-hand engine mountings.

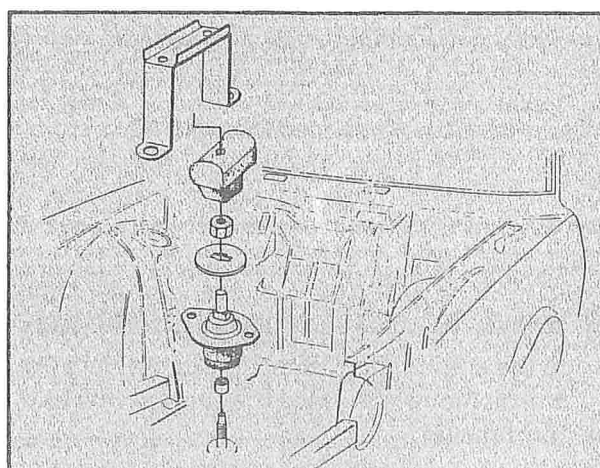

Front engine mounting

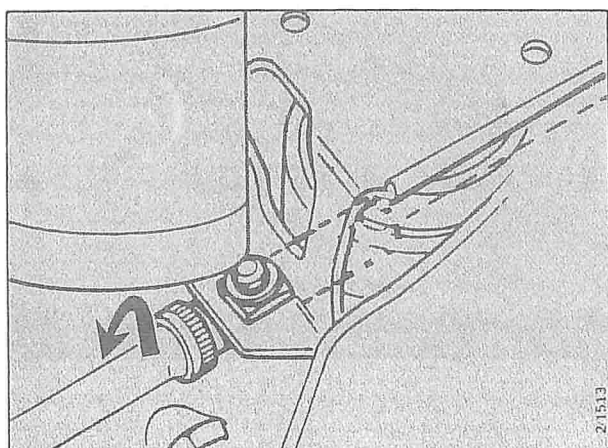

Left-hand engine mounting

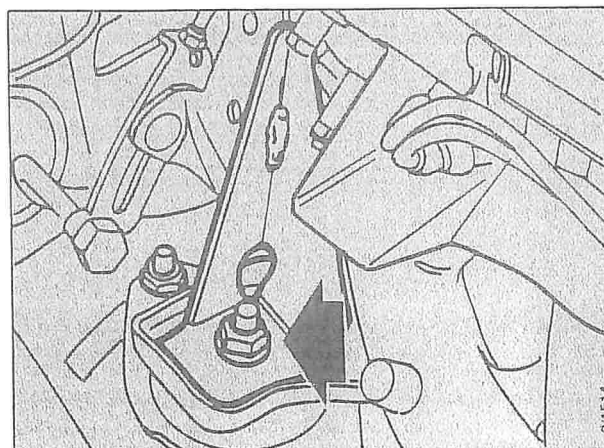

Right-hand engine mounting

Cars with air conditioner have a notch in the AC bracket for a lifting hook.

If the bracket has been removed, fit a separate lifting lug 93 13 222 instead to the water pump cover.

Use the existing bolts.

- 40 Secure the lifting yoke to the power unit and lift the power unit so that the left-hand inner universal joint can be separated.

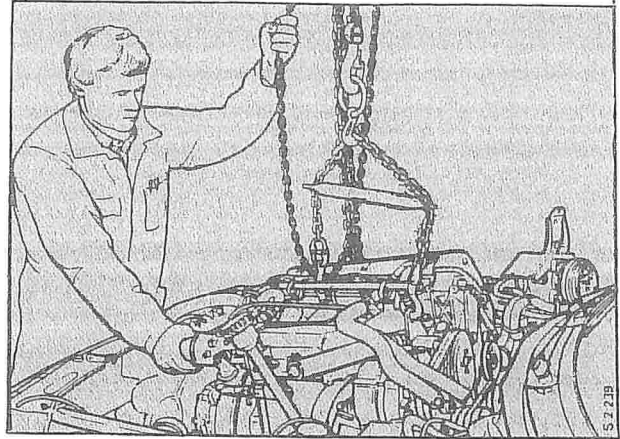

- 41 Disconnect the steering servo pump return line.

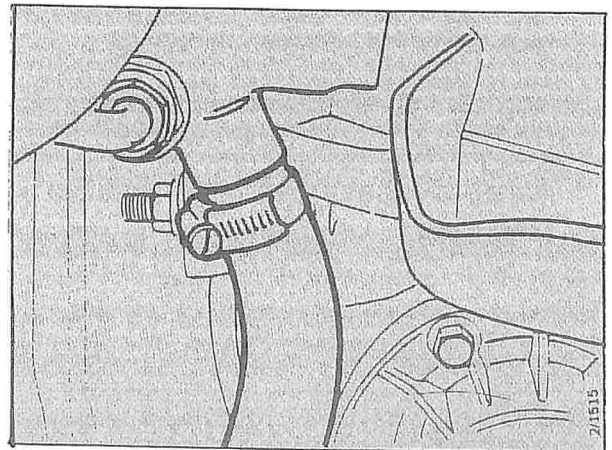

- 42 Remove the oil pressure sensor and disconnect the hoses for the air-cooled oil cooler from the oil filter housing.

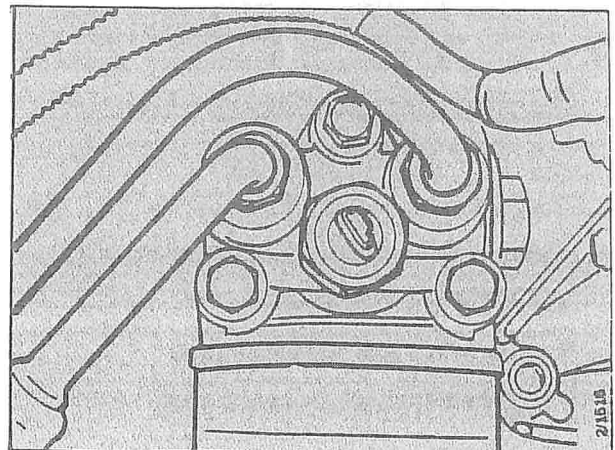

43 Lift out the power unit.

Keep the power unit close to the bulkhead to avoid damage to the radiator and solenoid valve.

Fit protective caps to the universal joint drivers.

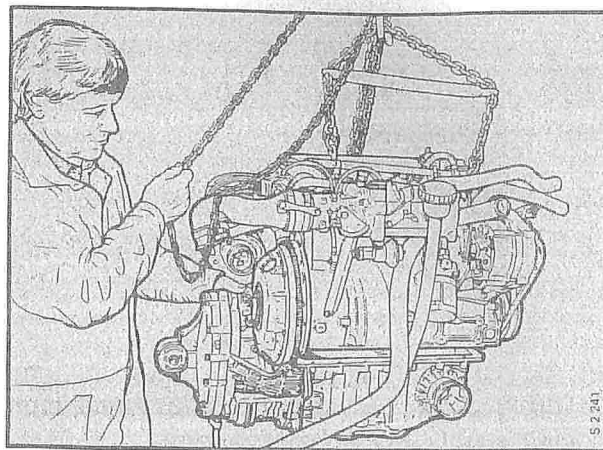

To fit the power unit

- 1 Check that the universal joints are packed with grease.

Fit the drain plugs for the cooling system

- 2 Suspend the power unit from the lifting yoke so that the front engine mounting is somewhat lower than the rear mountings.

- 3 Lower the power unit into the engine compartment down to a height at which the oil cooler hoses, the oil pressure sensor and the steering servo pump return hose can be connected.

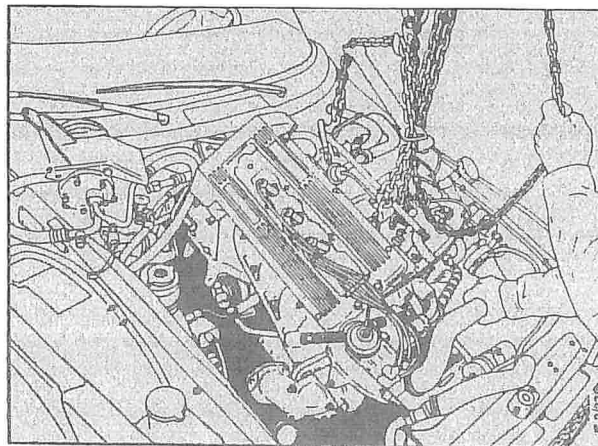

- 4 Align the power unit in the following order:

- front engine mounting
- left-hand inner universal joint
- right-hand inner universal joint

Then lower the power unit onto the rear engine mountings and fit the bolts. Don't forget the spacer sleeve for the left-hand mounting.

- 5 Unhook the lifting yoke hooks and, if applicable, remove the lifting lug from the water pump (car with AC).
- 6 If the car is equipped with an AC:
 - Fit the AC compressor.
 - Fit the drive belt and tension it.
- 7 Connect the coupling on the delivery side of the steering servo pump.

- 8 Secure the exhaust pipe loosely to the exhaust manifold.
- 9 Lift the car to a suitable height and fit the end piece to the bottom wishbone and the anti-roll bar.

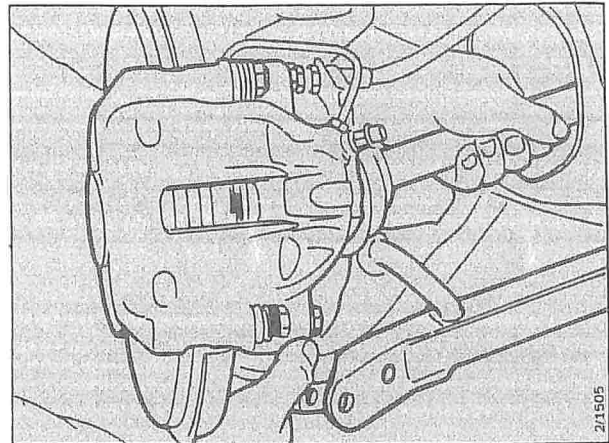

Refit the wheel.

- 10 Lift the car and fit the following:
 - a The rubber gaiters and clips to the universal joints.

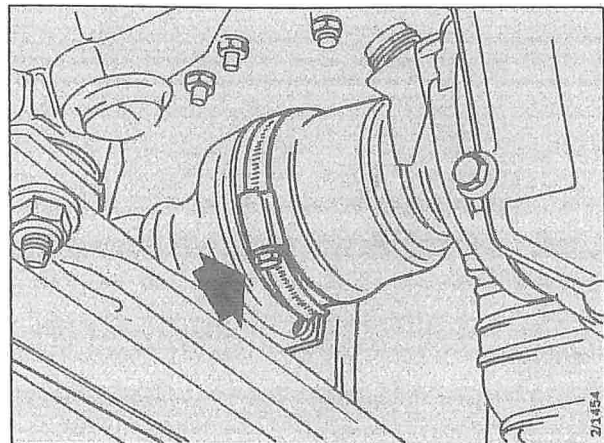

431-40 Removing and fitting

- b The bolts for the exhaust pipe bracket to the gearcase.

The exhaust pipe clamp may have to be slackened slightly to enable the bracket to be bolted to the gearcase.

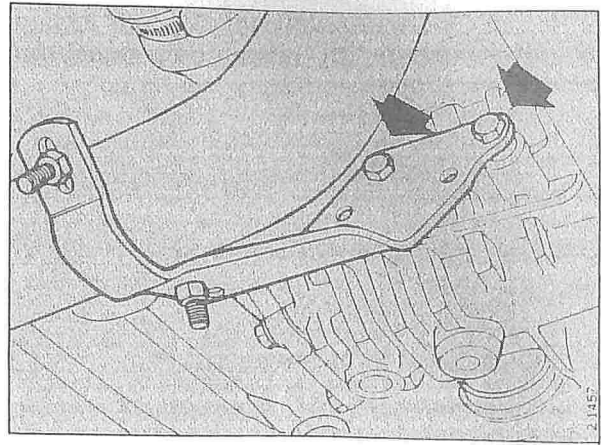

- c Speedometer cable.

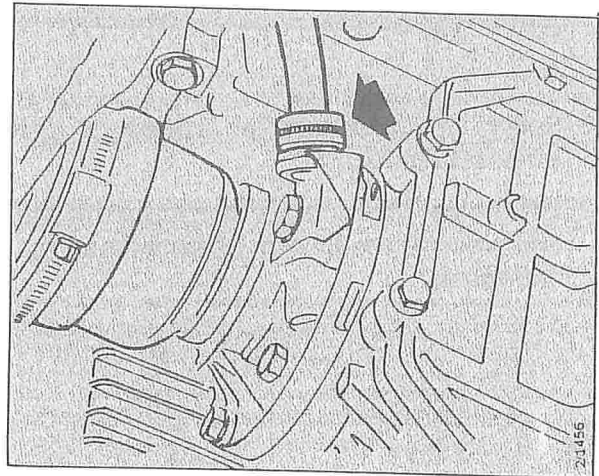

- d Selector rod taper pin.

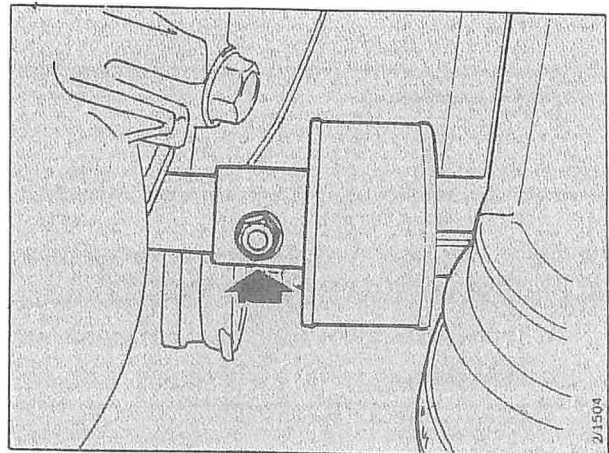

- 11 Lower the car to a suitable working height and connect the earth cable to the timing gear cover.

Run the positive cable into place and fit the clips.

- 12 Remove tool 83 93 209 under the right-hand upper wishbone and tighten the wheel nuts.

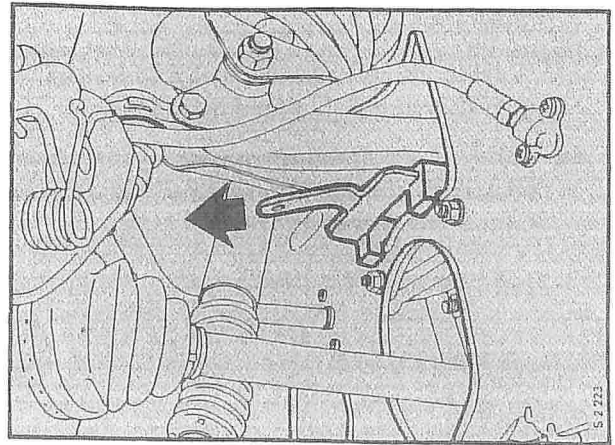

**Tightening torque for the wheel nuts:
105 - 125 Nm (77 - 92 lbf ft)**

- 13 Tighten the exhaust pipe flange bolts.
- 14 Connect the Lambda sensor connector and secure the cable with straps to the AC hose.

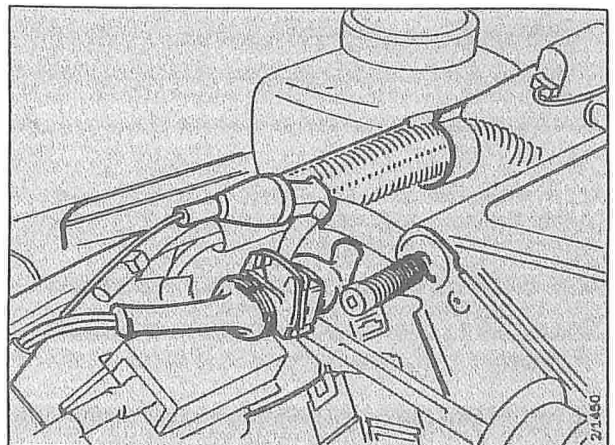

- 15 Connect the radiator hose to the bottom of the radiator and connect the hydraulic line to the clutch slave cylinder.

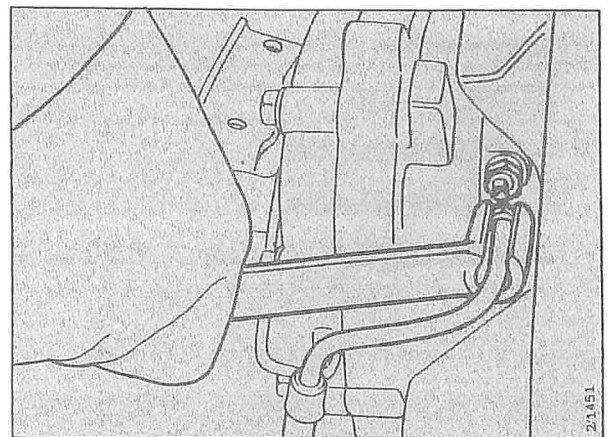

Bleed the clutch (see section 411).

431-42 Removing and fitting

- 16 Connect the battery positive cable to the starter motor.
- 17 Connect the fuel lines to the fuel distribution pipe and to the fuel pressure sensor.
- 18 Connect the vacuum hoses for the brake servo to the intake manifold and the vacuum tank system to the throttle housing.

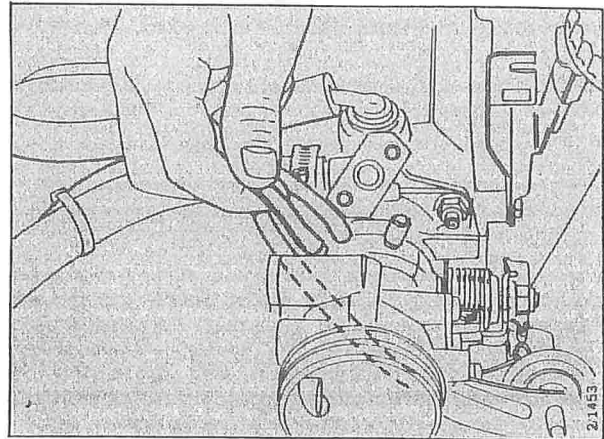
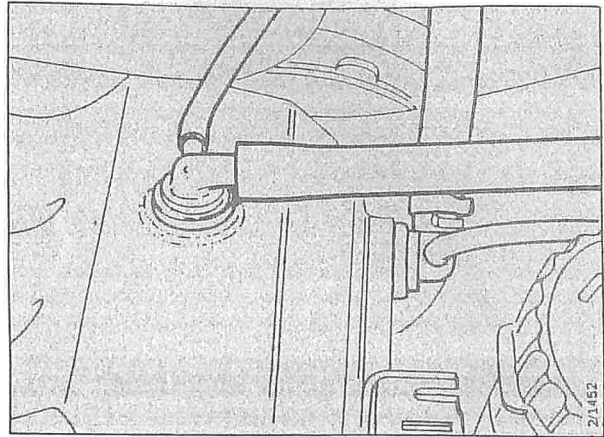

- 19 Connect the throttle cable and electric cable.
- 20 Refit the cable harness to the left-hand side of the engine and connect the cables to:
 - a temperature sensor
 - b Hall sensor
 - c alternator
 - d starter motor
 - e AC throttle switch
 - f oil pressure sensor
 - g knock sensor
- 21 Secure the cable harness with straps to the positive cable (also between the starter motor and alternator) and to the hoses for the air-cooled oil cooler.

431-44 Removing and fitting

- 22 Connect the radiator hoses to the expansion tank and the heat exchanger valve.
- 23 Fit the extra radiator fan for the AC system.
- 24 Fit the intercooler side plate.
- 25 Remove the cap from the inlet pipe of the turbocharger and fit the intercooler together with the air hose. Fit the cover over the radiator.
- 26 Connect the solenoid valve signal hoses.

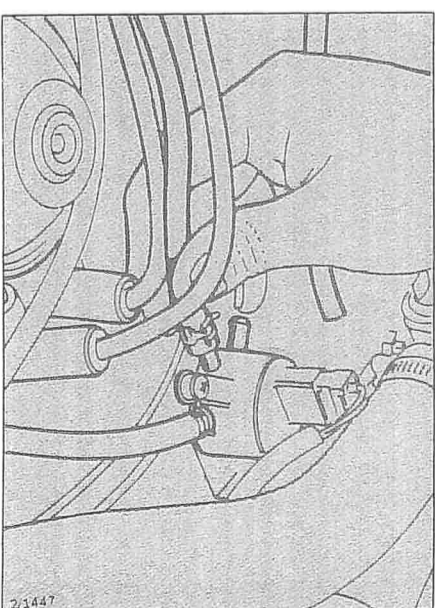

- 27 Connect the radiator hose to the thermostat housing.
- 28 Fit the ignition coil and connect the lead to the distributor cap.
- 29 Fit the cable harness and the wiring for the LH system and connect the cables to:
 - a AC compressor temperature switch (Fig. g)
 - b AC temperature sensor (Fig. i)
 - c throttle switch (Fig. b)
 - d temperature switch for the AC fan (Fig. h)
 - e temperature sensor (Fig. d)
 - f earthing points at the lifting lug (Fig. e)Don't forget the earth connection from the left-hand cable harness
- 30 Fit the oil filler pipe.
- 31 Fit the air cleaner together with the "snorkel".
- 32 Fit the air mass meter together with the bellows.
 - a Connect the connector (Fig. a)

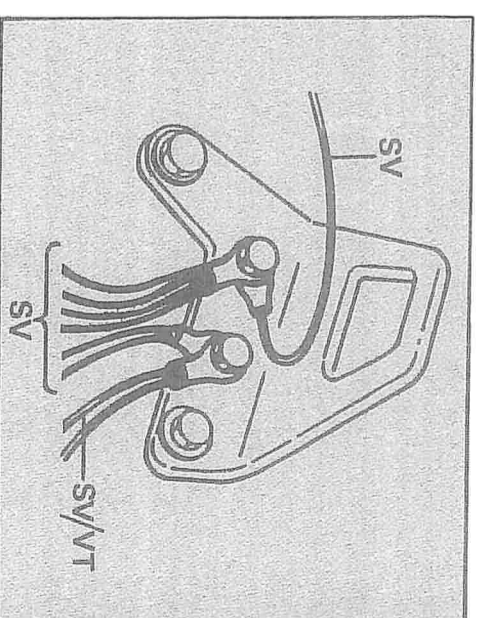

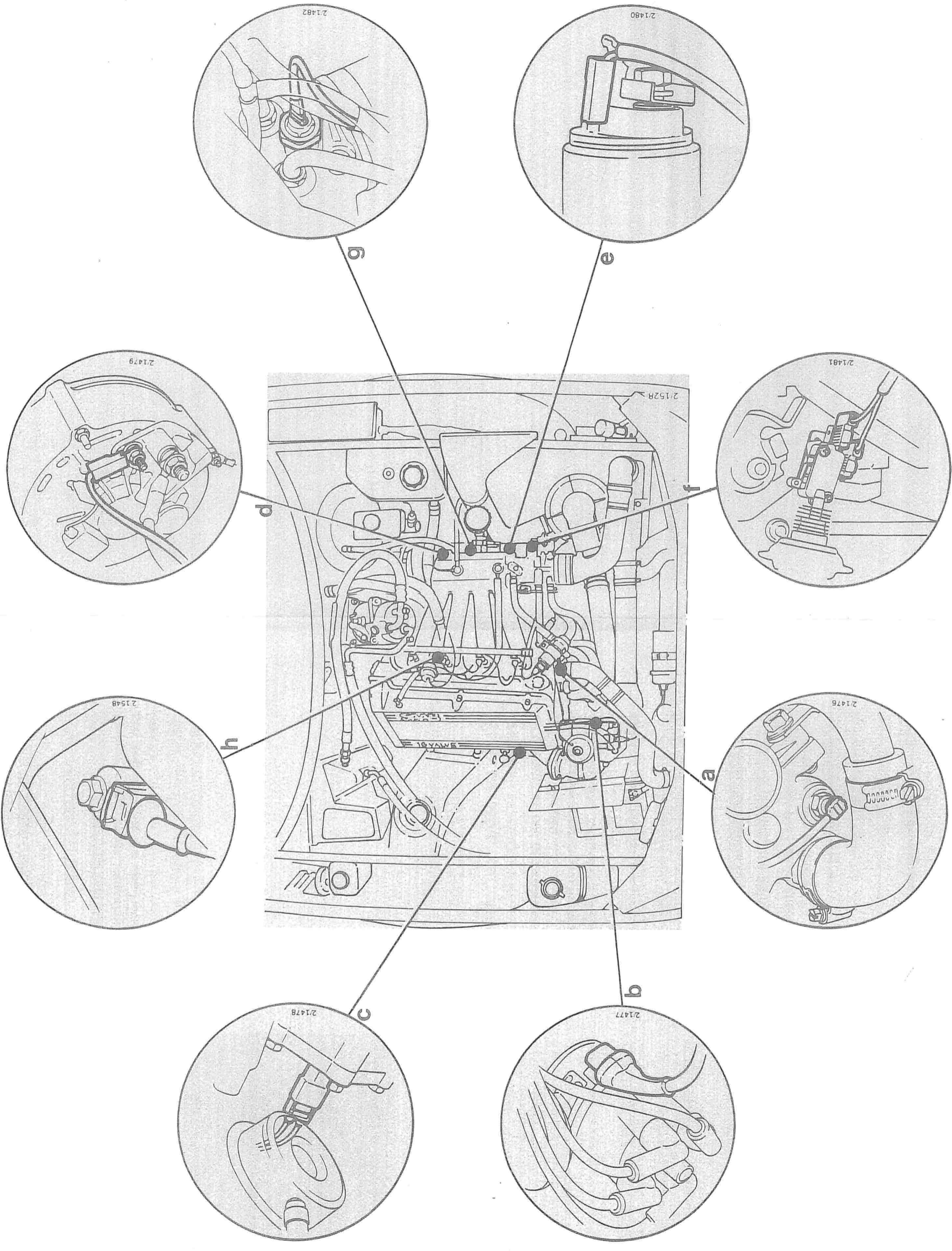

Connecting the left-hand cable harness to the B202 engine

431-46 Removing and fitting

- 33 Fit the turbocharger delivery pipe between the intercooler and the throttle housing.
- 34 Fill the steering servo reservoir with Texaco Power Steering Fluid 4634 or equivalent.
- 35 Fill the cooling system with coolant and pressure test it.
- 36 Fit the battery and connect the cables.
- 37 Fit the bonnet and connect the hose for the windscreen washers.
- 38 Start the engine, check the various functions and check that none of the hoses are leaking.

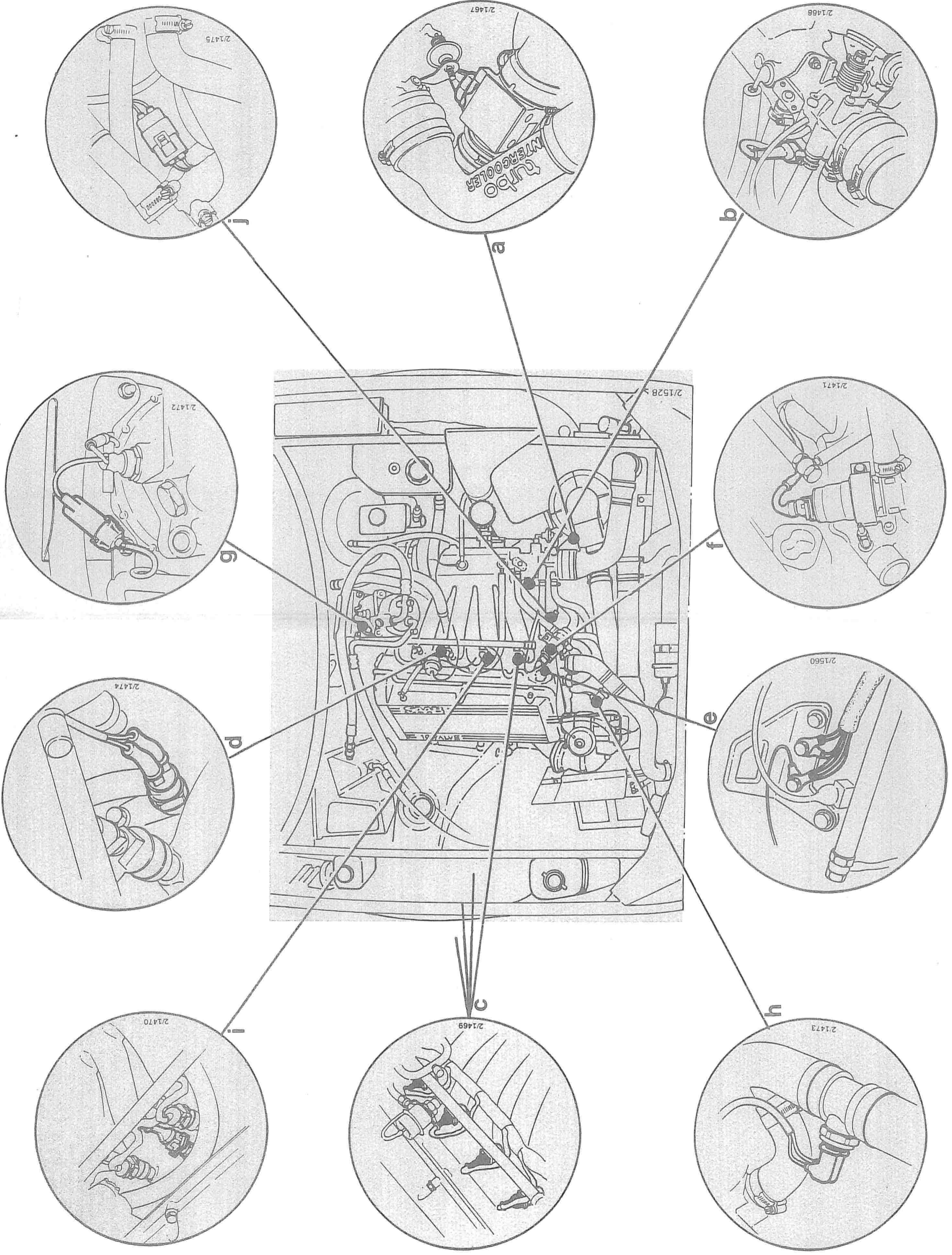

Connecting the cable harness with the LH system wiring to the B202 engine

To separate the engine (B201 and B202) from the gearbox

- 1 Clean the outside of the engine and gearbox.
- 2 Drain the engine oil. Remove the EGR pipe.
- 3 Remove the flywheel housing cover. Remove the oil dipstick pipe. Remove the oil return pipe from the turbocharger.
- 4 Remove the starter motor. Remove the stay plate for the starter motor.
- 5 Withdraw the clutch shaft using sliding hammer 83 90 270 and adapter 87 90 529.

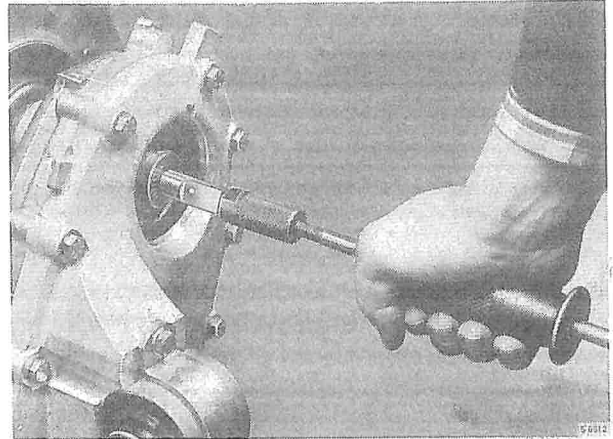

- 6 Remove the three slave cylinder mounting bolts.

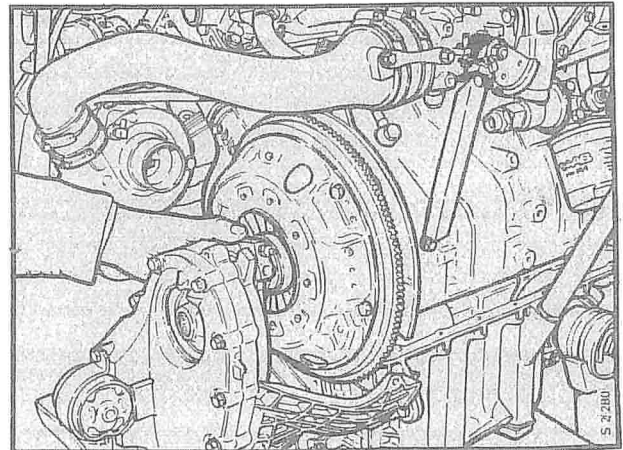
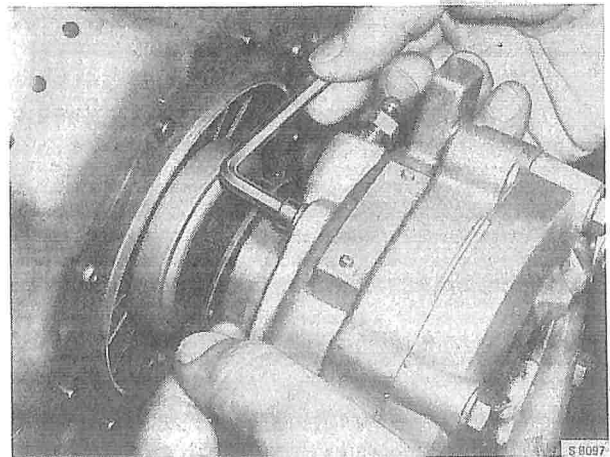

431-48 Removing and fitting

- 7 Remove all joint bolts between the engine and gearbox. Release the oil filler pipe bracket at the throttle control in the intake manifold.
- 8 Carefully lift the engine off the gearbox (see figure), at the same time removing the release bearing guide sleeve.
- 9 Remove the oil pump suction pipe with O-ring.

Caution

If the engine does not separate easily from the gearbox, do not try to prise it away until you have checked that all bolts have been removed.

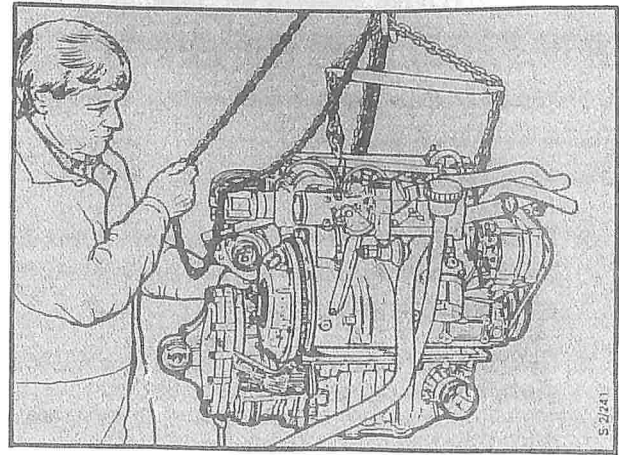

S 2/241

Before mounting the engine on the gearbox

- Make sure that the joint faces of the engine and gearbox are thoroughly clean.
- Make sure that the two locating sleeves are fitted to the gearbox.
- Fit a new gasket to the gearcase joint face. Apply sealing compound to both grooves in the gasket as shown in the upper figure.
- Apply thread sealing compound to the six bolts marked in the figure.

Assemble in the reverse order.

Note

The guide sleeve for the release bearing must be held in position against the clutch as the engine is being lowered onto the gearbox.

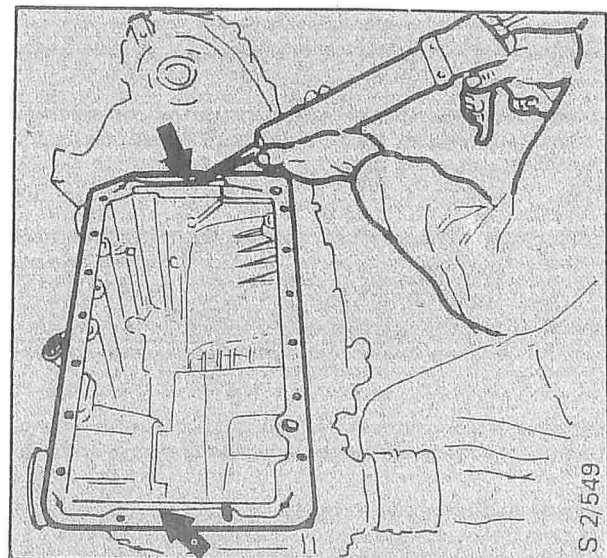

S 2/549

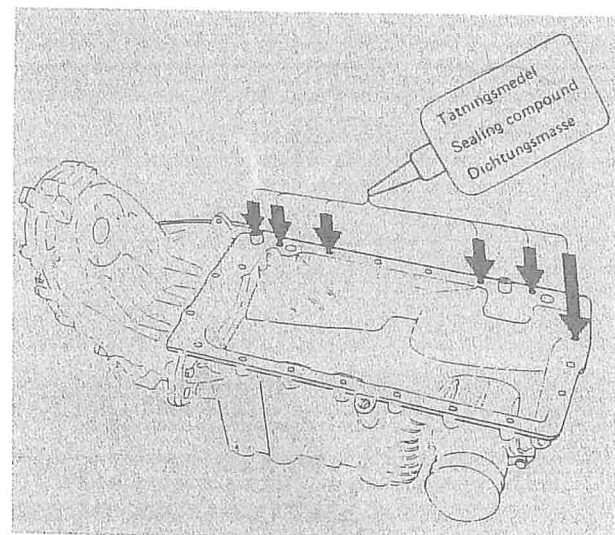

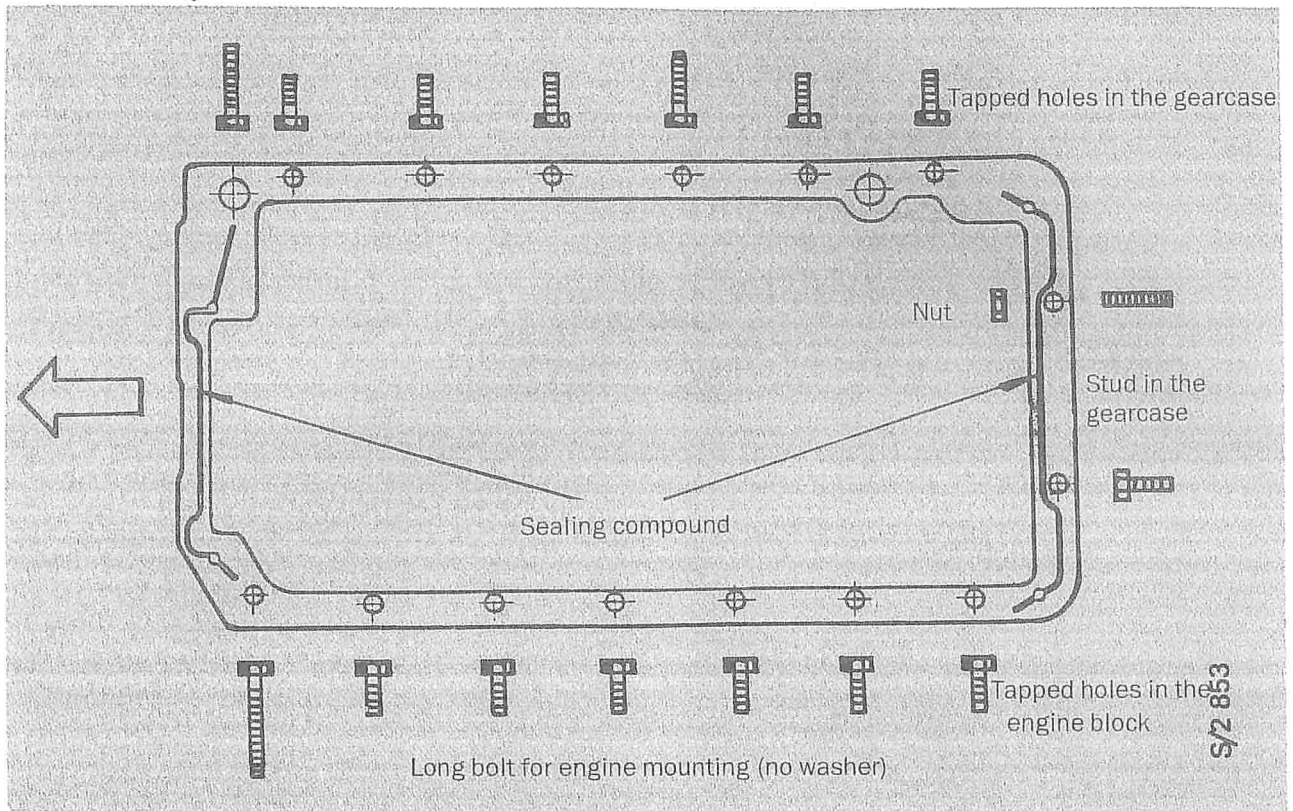

Tightening torque for the engine/gearbox joint bolts
25 Nm ± 3 Nm (18.5 ± 2.2 lbf ft)

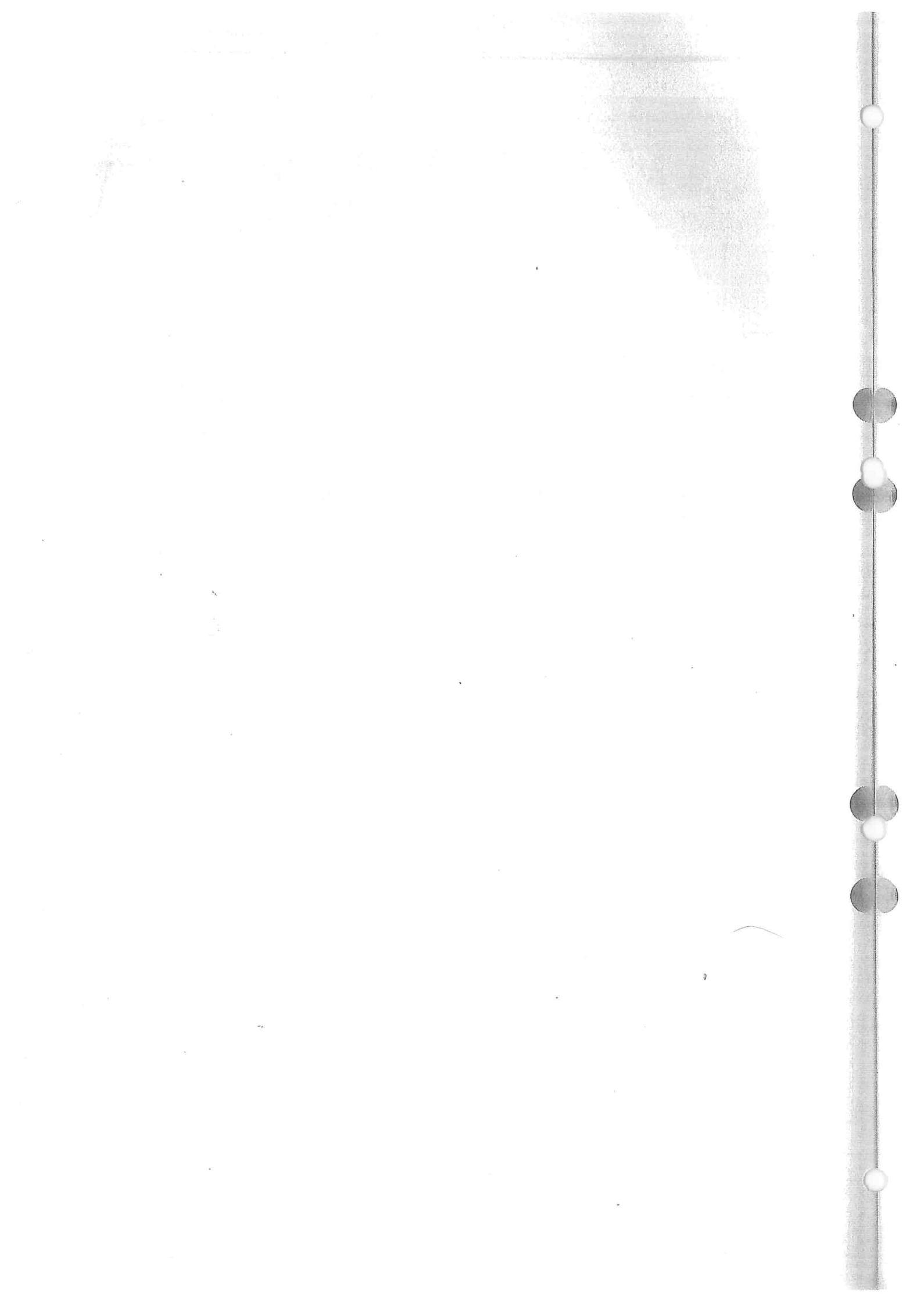

Gearbox control

Gear lever lock	432-1	Lock barrel	432- 6
To remove the gear lever housing complete with ignition switch	432-2	Centre console, rear section	432- 7
To fit the ignition switch and gear lever housing	432-4	To remove the front section of the centre console	432- 9
To change the selector rod	432-5	To preset and adjust the gear positions	432-10
		Gear lever	432-12

General

A floor-mounted lever located between the front seats is used for gear changing.

The gear lever is fitted with a reverse gear latch which can be released by lifting the sleeve below the gear lever knob.

The gearbox control system also includes a gear lever housing secured to the floor between the front seats and a selector rod which transmits the gear lever movements to the gearbox.

The gear lever is spring-loaded to the 3rd/4th gates. A slight spring force must therefore be overcome when selecting 1st, 2nd, 5th or reverse gear.

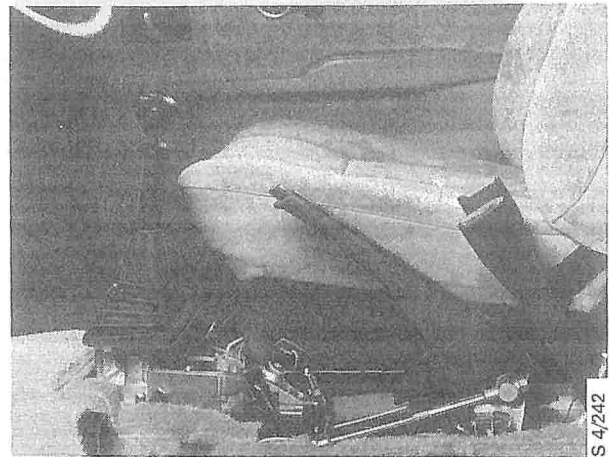

Gear lever lock

General

The car is equipped with a combined ignition switch and gear lever lock. When reverse gear is engaged and the ignition key is removed, the gear lever will be locked in the reverse position. The ignition switch has the following positions:

- L Locked. Before the key can be turned to this position, reverse gear must be engaged, and the key can only be withdrawn when the gear lever is in the reverse position. The parking lights and hazard warning lights can be switched on when the ignition key is in this position.
- G Garage. All lights can be switched on.
- K Drive. The entire electrical system, including the ignition circuit, is live.
- S Start. In this position, the key is spring-loaded to return to K.

The gear lever lock consists of a locking plate (3) and gearwheel (4) actuated by a toothed segment (5) fitted under the lock barrel (6). The segment turns with the lock barrel.

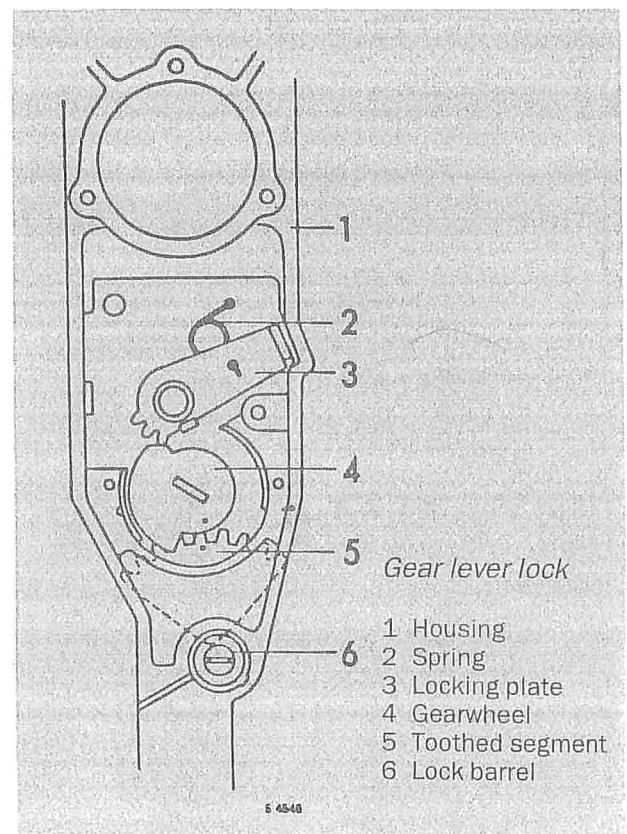

To remove the gear lever housing complete with ignition switch

- 1 Disconnect the negative cable from the battery.
- 2 Remove the left-hand front seat.
- 3 Remove the kick-plate and strip at the A pillar.
- 4 Remove the front section of the centre console (see page 432-9).
- 5 Fold back the carpet and remove the ventilation air duct.
- 6 Disconnect the cables from the ignition switch and reversing light switch. Mark the cables.

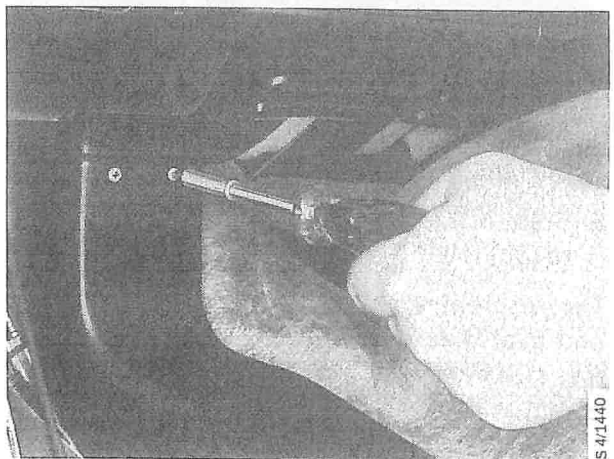
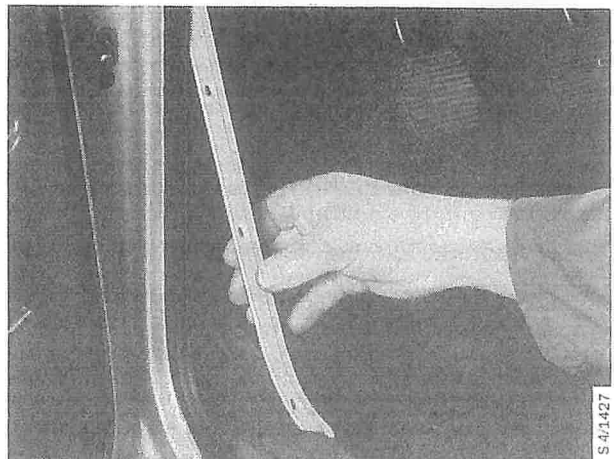
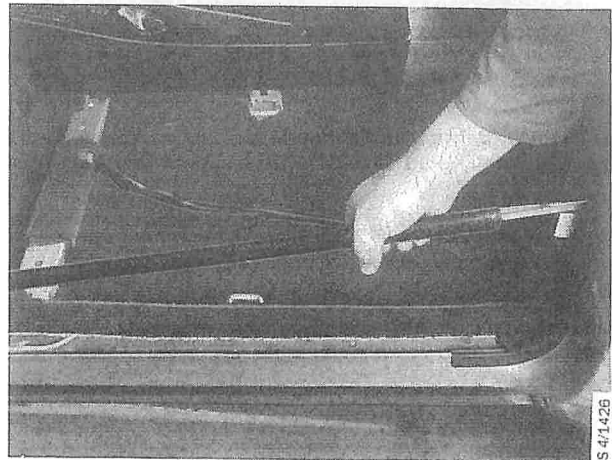
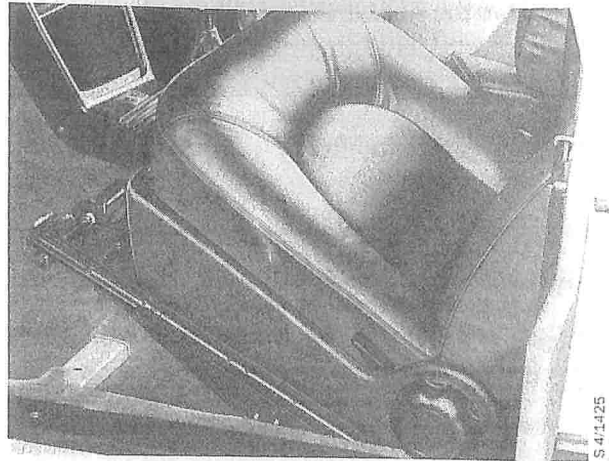

- 7 Remove the two screws for the support bracket.

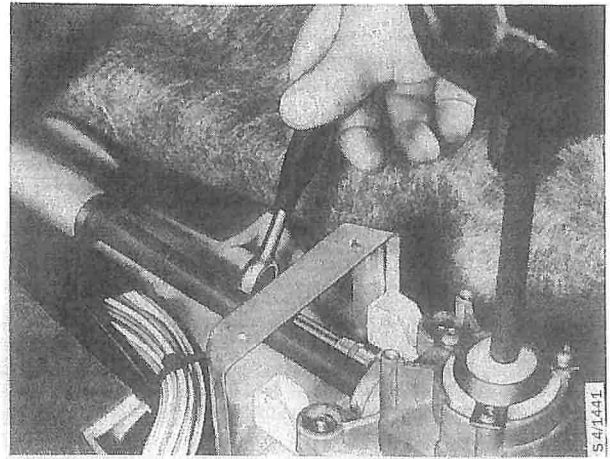

Use special socket 87 90 370 to remove the gear lever housing bolts.

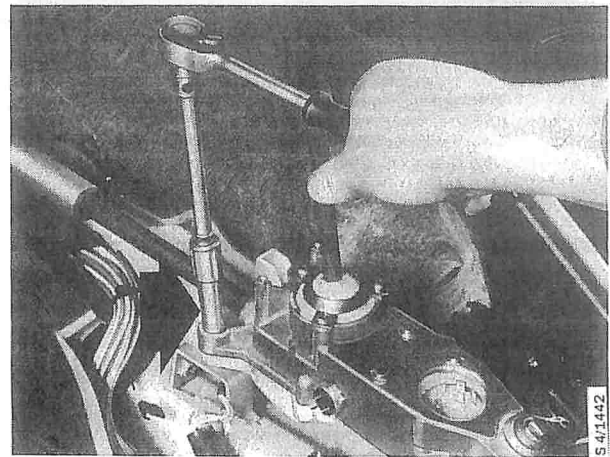

Hylsa 87 90 370

- 8 Raise the gear lever housing and turn it so that the cover plate bolts can be removed from the underside of the gear lever housing, and remove the cover plate.



(To remove the entire gear lever housing, remove the two screws securing the plastic bottom section, and then remove the gear lever housing.)

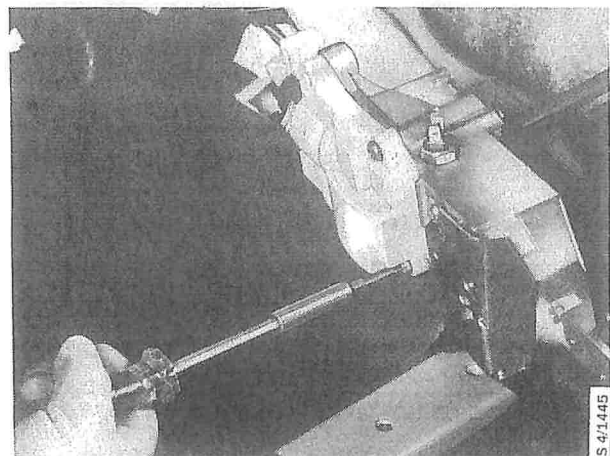

- 9 Remove the two ignition switch screws and remove the switch.

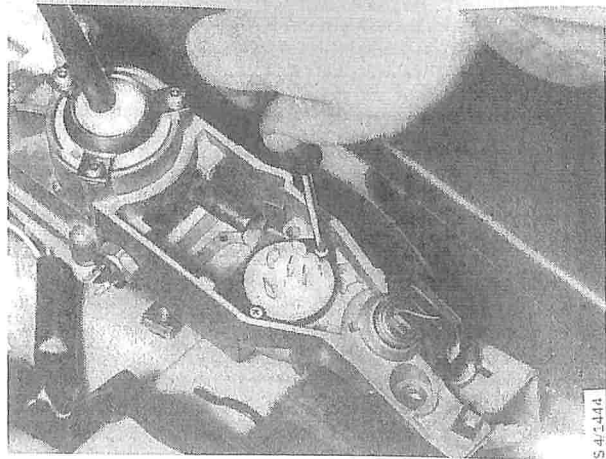

To fit the ignition switch and gear lever housing

- 1 Insert a screwdriver into the slot (4) and turn the switch so that the mark (2) is in line with the arrow (3).
- 2 Turn the ignition key to position L (locked).
- 3 Fit the switch with the locating pad (1) in the corresponding slot in the gear lever housing.

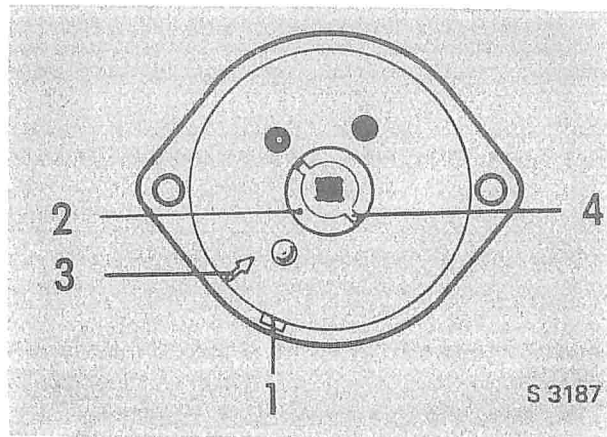

Ignition switch (viewed from the underside)

- 1 Locating pad
- 2 Setting mark
- 3 Arrow
- 4 Drive slot

- 4 Turn the ignition switch back and forth to check that the gear lever locking mechanism does not bind or jam.

- 5 Fit the cover plate.

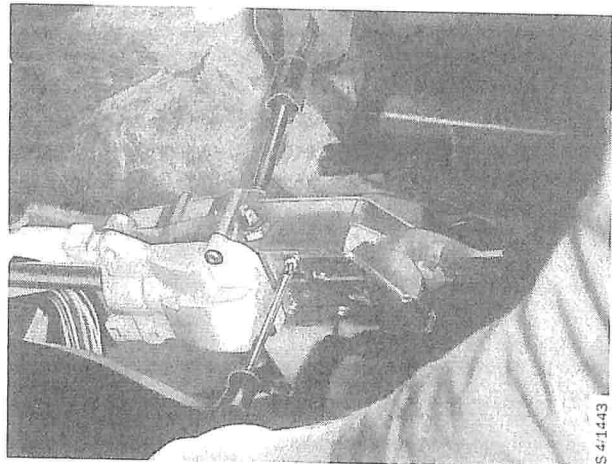

6 Fit the gear lever housing. Bolt the bracket in position.

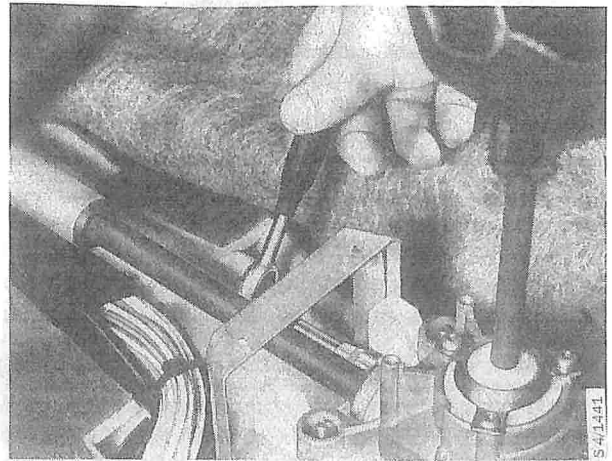

7 Connect the cables to the ignition switch and the reversing light switch.

8 Fit the ventilation air duct and fold back the carpet. Fit the kick-plate and strip.

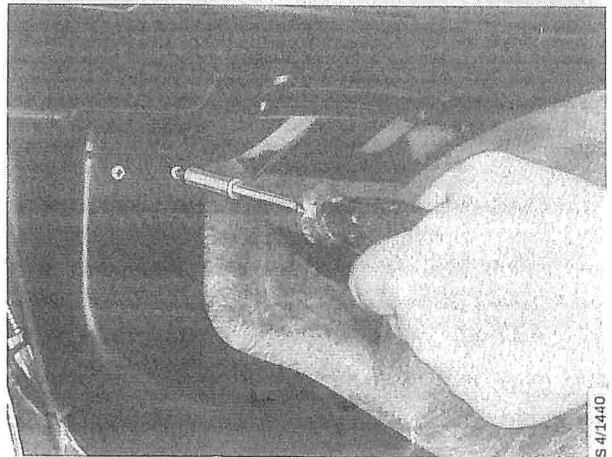

9 Fit the centre console.

10 Fit the front seat.

11 Connect the battery cable.

To change the selector rod

1 Follow the description for removing the gear lever housing up to the point at which the housing can be removed.

2 Lift the car and release the clamp on the selector rod.

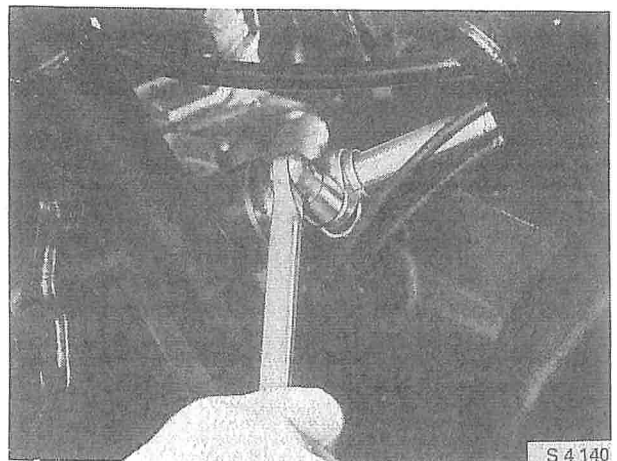

- 3 Lower the car and withdraw the selector rod into the car. Check and, if necessary, change the rubber gaiter.
- 4 Fit a new selector rod and adjust the gear positions (see under "To preset and adjust the gear positions" on page 432-10).

If the universal joint needs changing, follow the description for changing the selector rod up to the point where the selector rod is withdrawn into the car.

The universal joint can then be changed. The gear positions must be adjusted as described under "To preset and adjust the gear positions" on page 432-10.

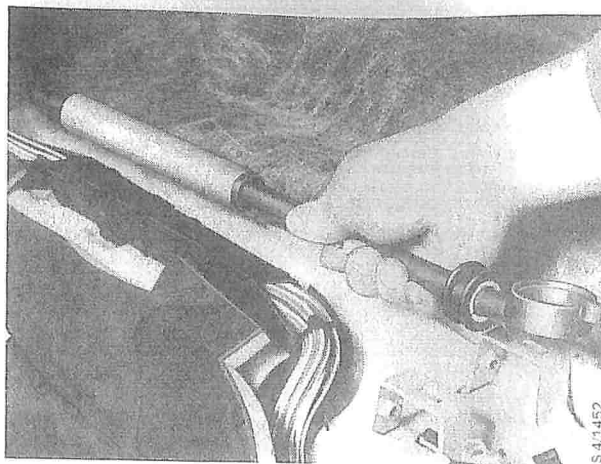

Lock barrel

To remove

- 1 Remove the gear lever housing (see "To remove the gear lever housing" on page 432-2).
- 2 Turn the ignition key to a position roughly mid-way between the locked and garage positions.
- 3 When the key is in this position, the lock barrel pin can be pressed in with a suitable rod inserted through a hole under the gear lever housing (see figure).
- 4 Remove the lock barrel.

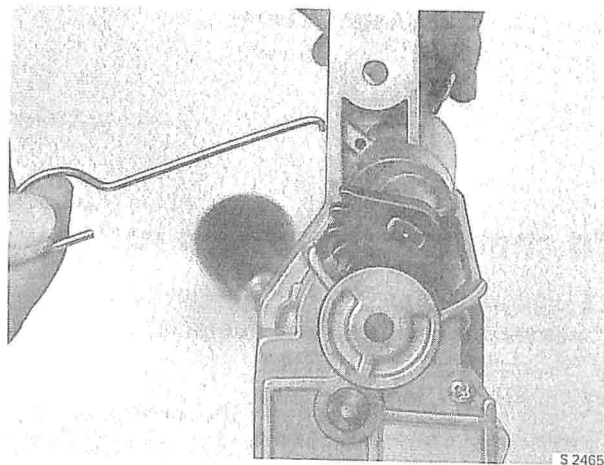
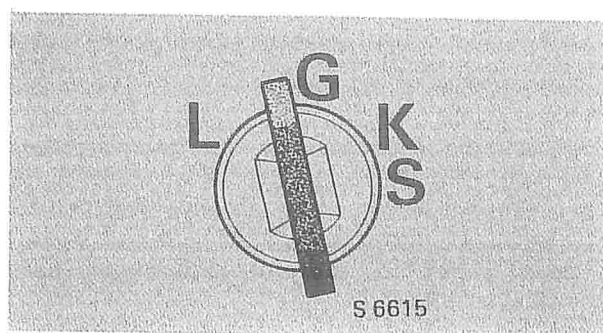

To fit

- 1 Turn the key in the lock barrel to a position roughly mid-way between the locked and garage positions.
- 2 Press in the lock barrel pin. Check that the toothed segment driver pins are in the correct position in relation to the lock barrel slot. Push in the lock barrel and check that it is in engagement with the toothed segment.
- 3 Fit the gear lever housing (see under "To fit the ignition switch and gear lever housing" on page 432-4).

To remove the lock barrel when the key is missing

To remove the lock barrel from the gear lever housing when the key is missing, proceed as follows (thereby destroying the lock barrel):

- 1 Remove the left-hand front seat.
- 2 Remove the centre console (see below).
- 3 Drill the plug out of the hole for the lock barrel pin in the gear lever housing.
- 4 Drive in the pin and remove the lock barrel.

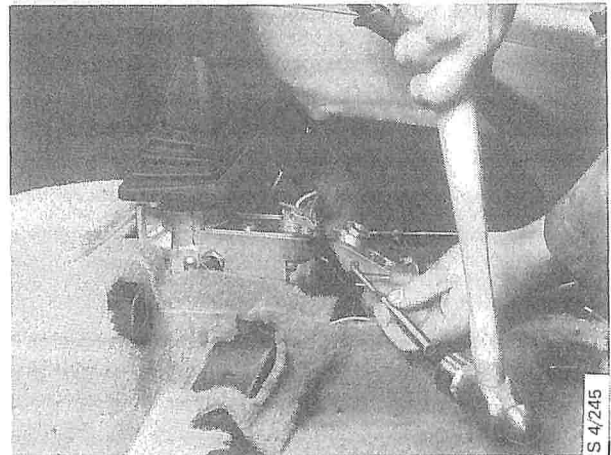

Centre console, rear section

To remove

- 1 Move the front seats to the rear limit of their fore-and-aft adjustment and apply the hand-brake. Remove the bellows piece between the front and rear centre consoles.

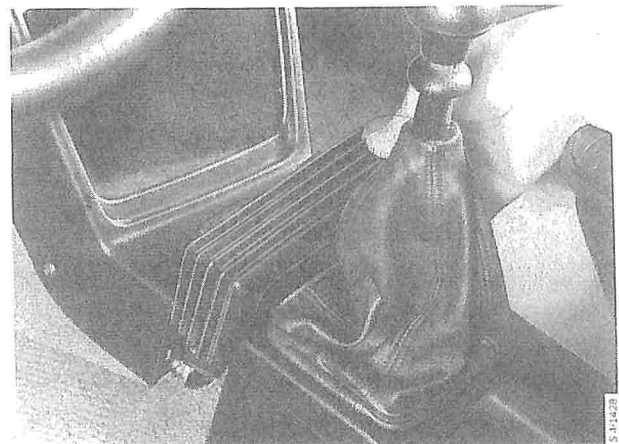

432-8 Gearbox control

- 2 Engage reverse gear and remove the ignition key.
- 3 Remove the gear lever gaiter.
- 4 Remove the two screws for the cover (top part of the console) and raise the cover so that the cables can be disconnected from the switch for the interior lighting. Insert the ignition key under the console, disengage reverse gear, and the cover can then be released from the gear lever.

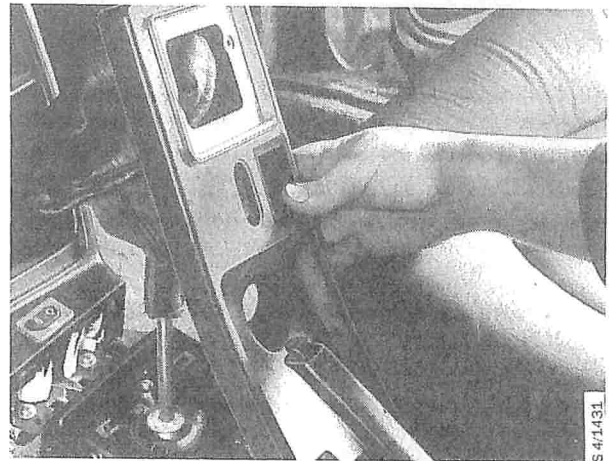
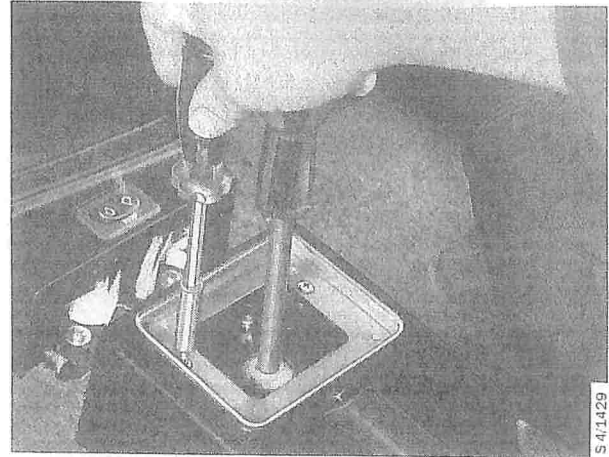

- 5 Remove the ashtray at the rear of the console. Remove the four screws. Raise the bottom console and remove the lamp for the ignition switch lighting. The console can then be released. If the car is equipped with electric windows, disconnect the connector.

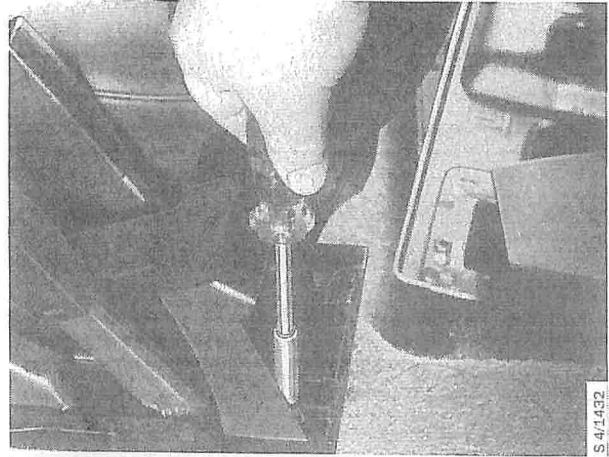

Assemble in the reverse order.

To remove the front section of the centre console

- 1 Remove the two screws at the bottom edge. If the car is equipped with an electric sunroof, disconnect the connector.

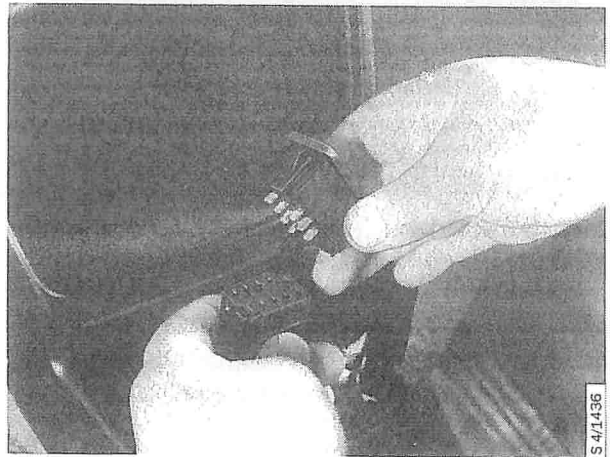
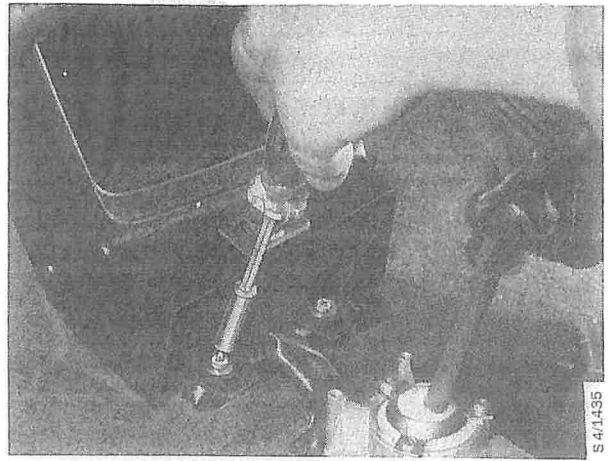

- 2 Remove the ashtray.
- 3 Remove the top screw for the console (behind the ashtray).

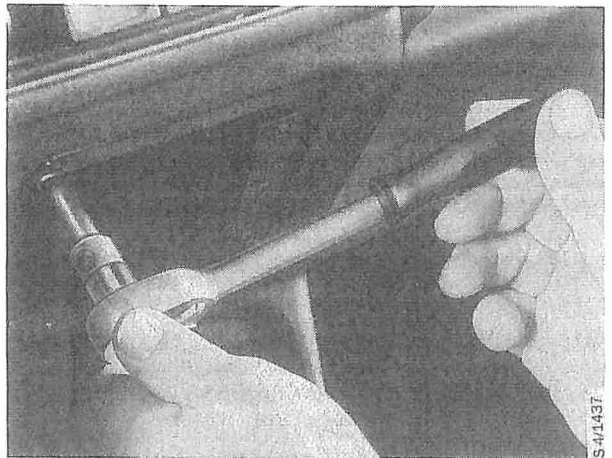

- 4 Withdraw the console, remove the ashtray lamp and remove the console.

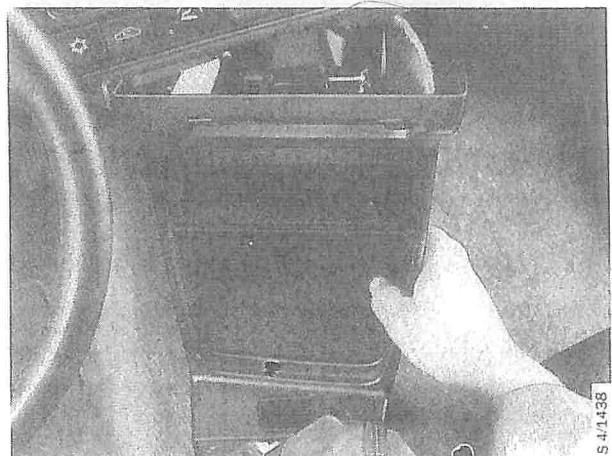

External gear-change mechanism

The external gear-change mechanism consists of the gear lever housing, gear lever, selector rod and selector rod universal joint. The clamp is used for adjustments.

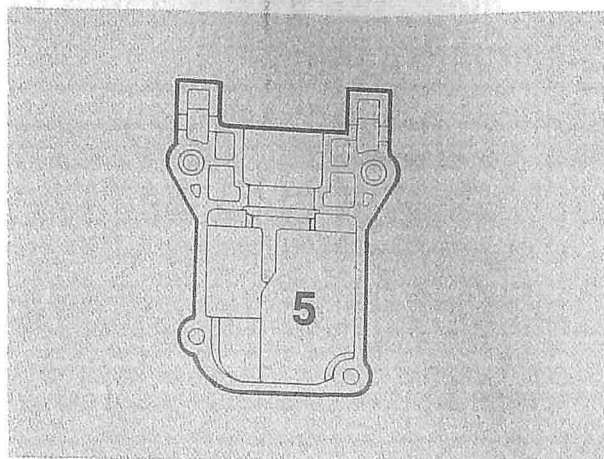

Bottom part of the gear lever housing

To preset and adjust the gear positions

- 1 Move the front seats to the rear limit of their fore-and-aft adjustment and apply the hand-brake. Remove the bellows piece between the front and rear centre consoles.
- 2 Engage reverse gear and remove the ignition key.
- 3 Remove the rubber gaiter and the two screws for the cover (top part of the console). Raise the cover so that the cables can be disconnected from the switch for the interior lighting. Insert the ignition key under the cover and disengage reverse gear. The cover can now be removed.

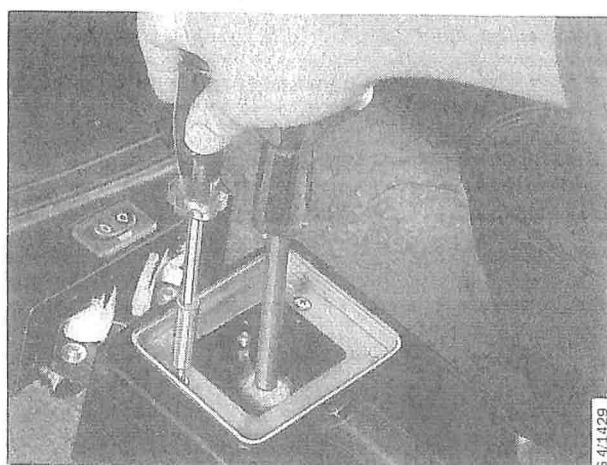
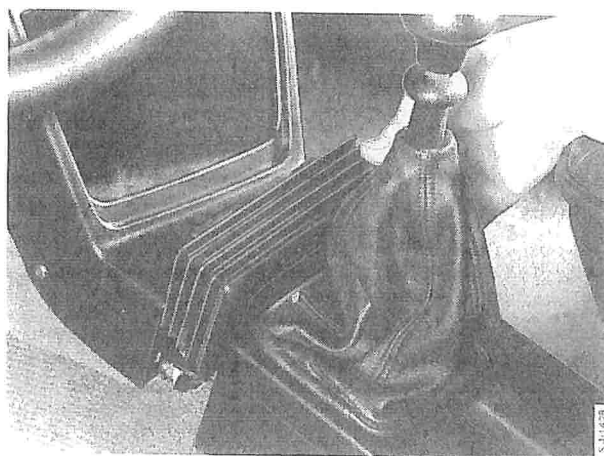

- 4 Remove the ashtray, remove the four screws and push the console towards the rear.

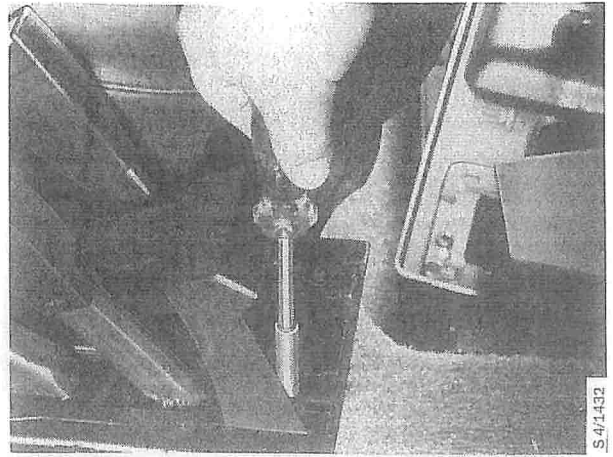

- 5 Engage 3rd gear, lift the car and insert tool 87 91 576 into the hole in the gearcase (see figure).

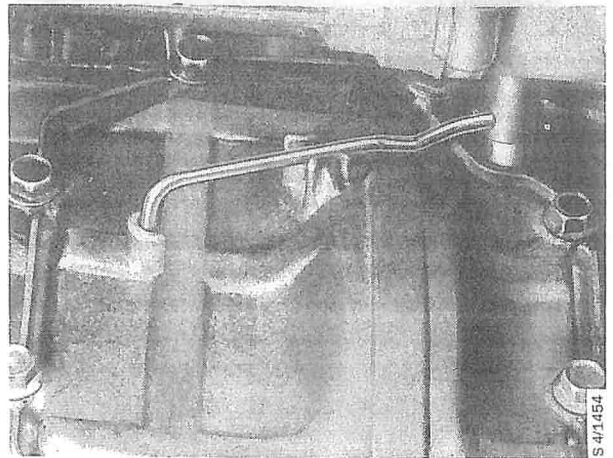

- 6 Release the clamp on the selector rod and lower the car.

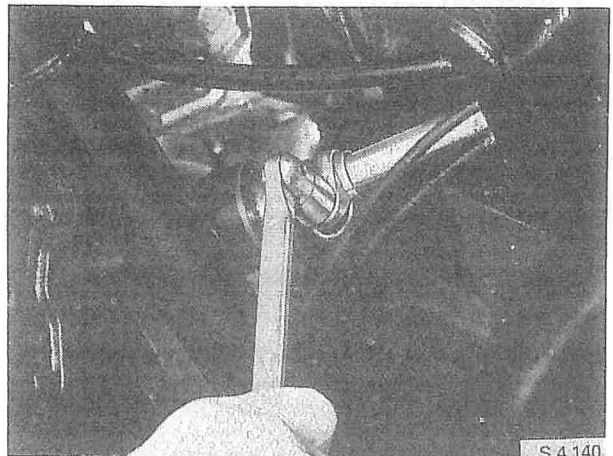

- 7 Insert a 6 mm dia. drift or a screwdriver into the locating hole in the gear lever housing (see figure).
- 8 Lift the car again and tighten the pinch bolt in the clamp. Remove the locking tool and lower the car.
- 9 Remove the drift or screwdriver from the locating hole, place the bottom part of the console in position and bolt it down.
- 10 Fit the top part of the console, with the gear lever in 3rd gear.
- 11 Bolt the console in position and fit the gear lever gaiter.
- 12 Fit the bellows piece between the front and rear consoles.

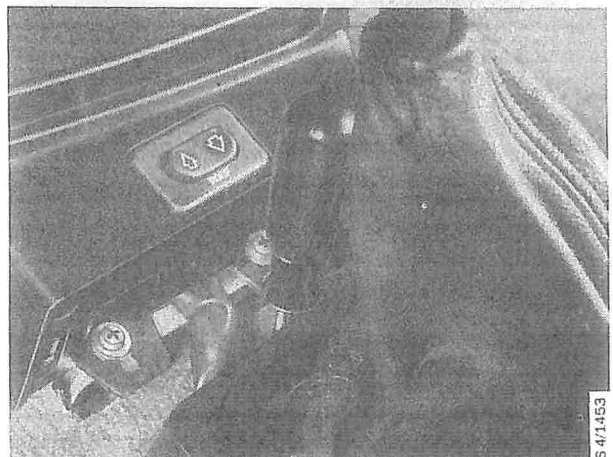

Gear lever

To remove

With the gear lever housing removed

The gear lever can also be removed by folding up the gaiter and removing the three screws retaining the gear lever.

- 1 Remove the gear lever from the gear lever housing.
- 2 Remove the tubular dowel and remove the sleeve, spring and bearing components.
- 3 Unscrew the latch stud from the latch rod.

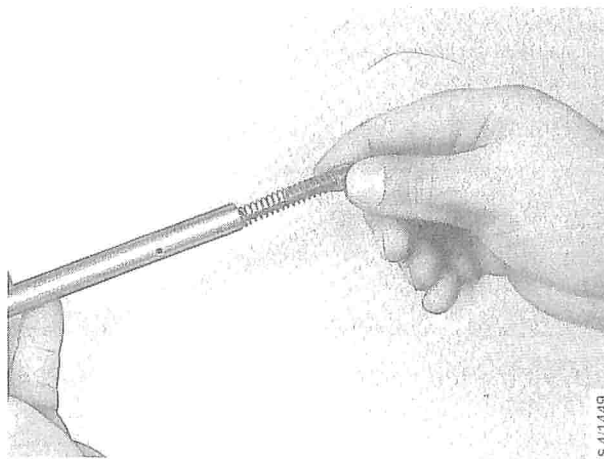
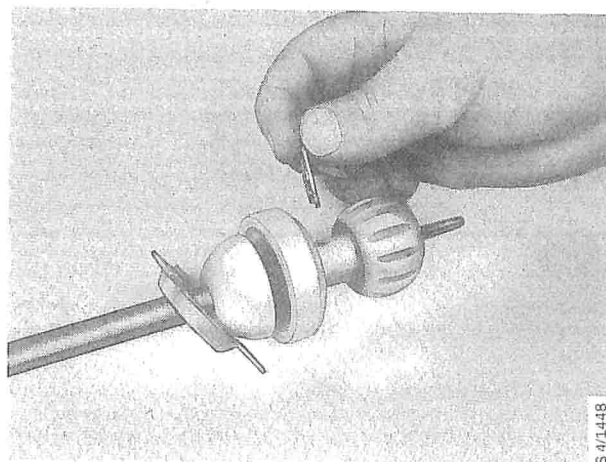
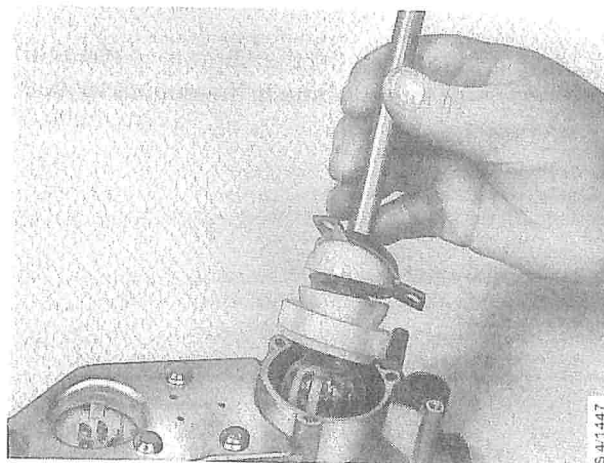

- 4 Remove the gaiter from the sleeve.
- 5 Remove the knob from the lever.

6 Remove the sleeve and the latch rod.

Assemble in the reverse order.

Ensure that the ground side of the rod is in such a position that the hole is open when the wire clip is fitted.



S 4/1450

Note

Before fitting the wire clip dowel, adjust the projecting length of the latch stud to $22 + 0.5/-0$ mm ($0.89 + 0.02/-0$ in)

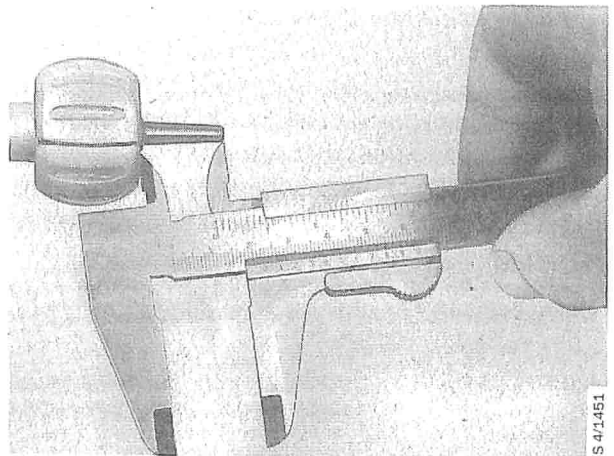

S 4/1451

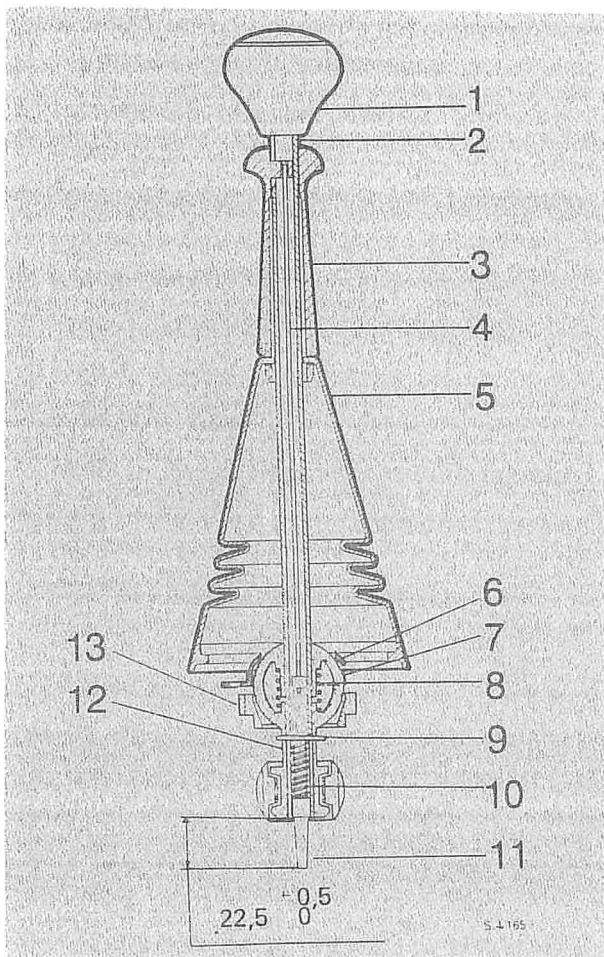

S 4/1455

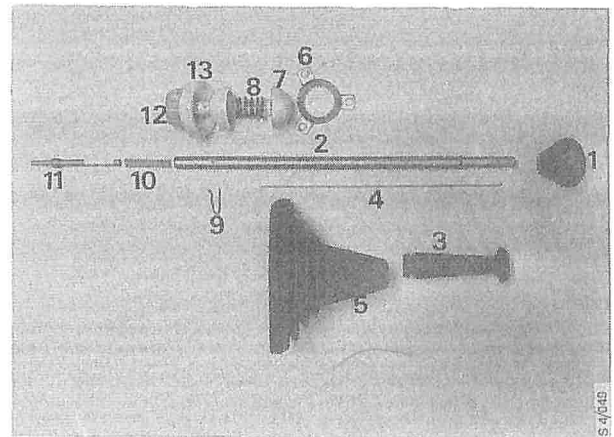

S 4/1449

Gear lever assembly

- | | |
|-----------------|---------------|
| 1 Knob | 8 Spring |
| 2 Gear lever | 9 Wire clip |
| 3 Sleeve | 10 Spring |
| 4 Latch rod | 11 Latch stud |
| 5 Rubber gaiter | 12 Carrier |
| 6 Cover | 13 Bearing |
| 7 Bearing | |

Faint, illegible text at the top left of the page.



Faint, illegible text at the bottom left of the page.

Dismantling and assembly

To dismantle	471- 1	Input shaft bearing housing	471-29
To assemble	471- 9	Selector mechanism	471-33
To adjust the differential support bearings	471-10	Selector shaft	471-34
Output shaft, to dismantle	471-21	Selector mechanism	471-35
Primary chain drive	471-28	Synchromesh mechanism	471-36
		Ventilation	471-39

Dismantling and assembly of the gearbox for repair can be carried out without separating the engine from the gearbox. But the engine flywheel and starter motor must first be removed. However, we recommend that the engine and gearbox should be separated.

To dismantle

(Proceed in the following order as far as necessary to remove the component that needs attention)

- 1 Wash the gearcase and drain the oil:
 - a with the gearbox horizontal
 - b with the gearbox vertical. Let the oil drain out of the primary chaincase.
- 2 Remove the following covers:

Front cover on the primary chaincase (the cover has a support bearing on Turbo cars).

Side cover on the primary chaincase (there will be some oil in the primary chaincase).

Side cover on the gearcase. Take care not to lose the spring.

Final drive cover.

Measure the backlash in the differential:
- 3 Fit a dial indicator into one of the holes for the cover bolts (final drive cover). Measure the backlash and note the value.

Important note

Always measure the positions of the pinion and crown wheel before dismantling the gearbox. This is to check whether their locations are correct. If the pinion and crown wheel assembly has been in service for a relatively short distance (less than 10 000 km) re-adjustment may be carried out. But if it has been in service for a longer distance and the gears have become worn-in, their settings during re-assembly should be the same as those measured before dismantling.

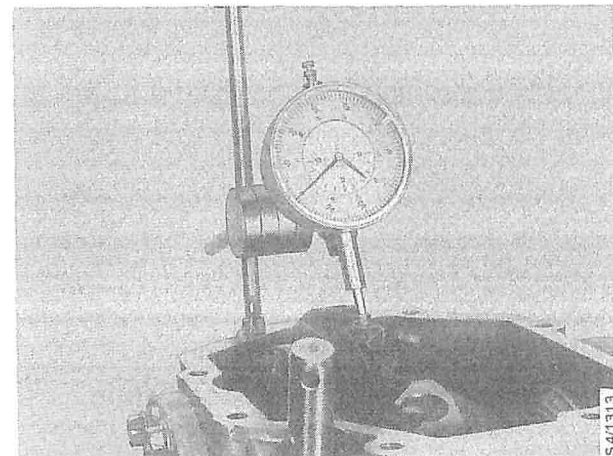
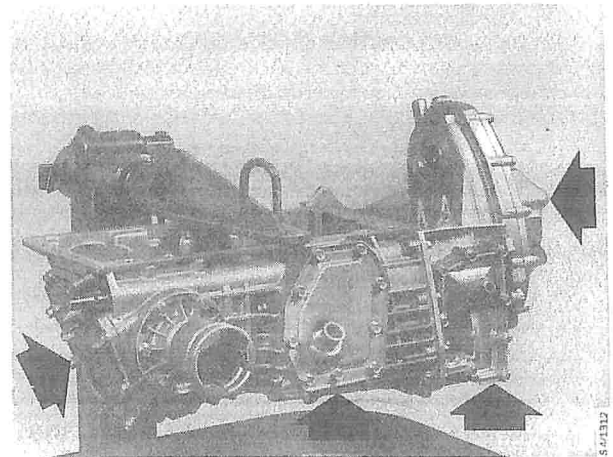

471-2 Dismantling and assembly

- 4 Remove the speedometer drive from the left-hand bearing housing. Remove the bearing housings on both sides.

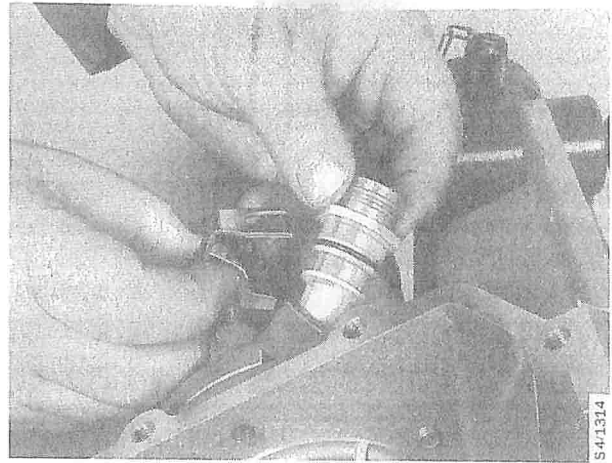

Use sliding hammer 83 90 270 and tool 83 90 776.

Save the spring and plunger at the shaft end of each universal joint driver, and save the shims which can be re-fitted if the differential backlash has not been altered by the replacement of some parts.

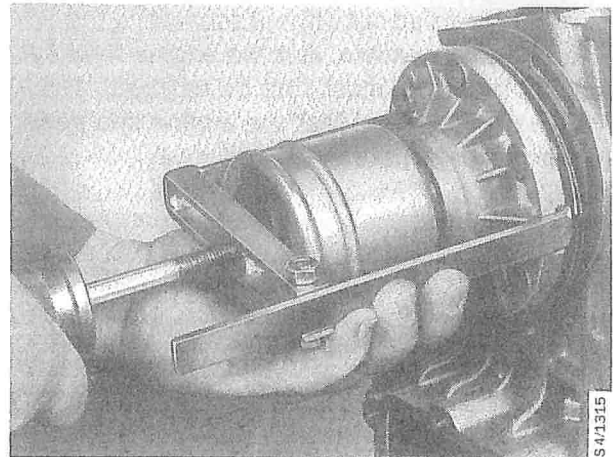

- 5 Remove the differential assembly. For dismantling instructions for the differential assembly, see section 473.

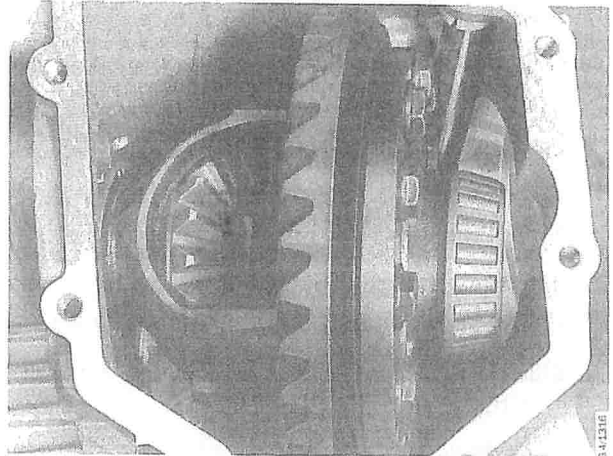

- 6 Measure the pinion distance and note the reading.

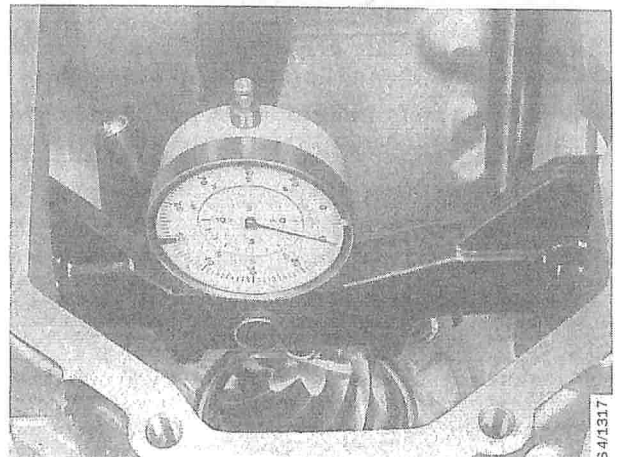

- 7 Remove the plunger from the 5th gear selector fork.
- 8 Move the reverse gear into the reverse position and engage 5th gear.

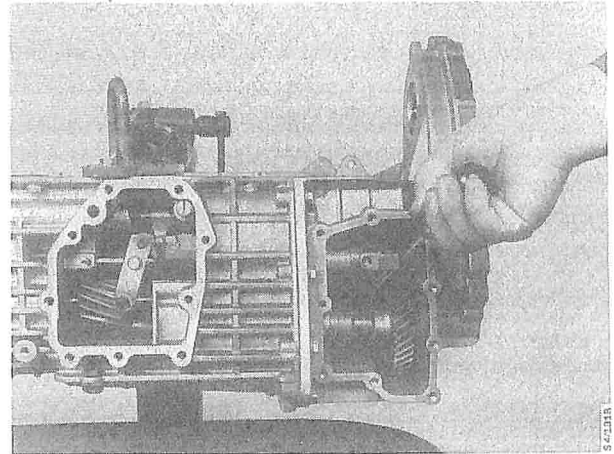

- 9 Use a drift to remove the peened-over material from the flange of the input shaft nut and remove the nut (bottom sprocket).

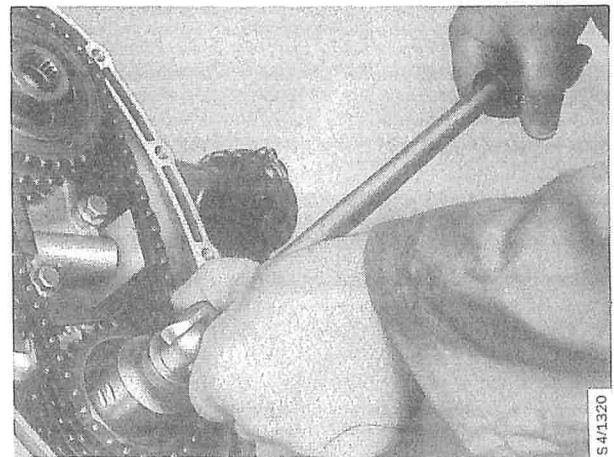
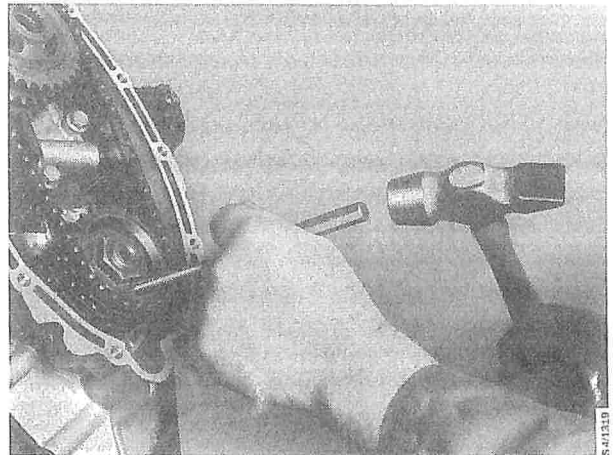

- 10 Remove the chain tensioner. Use a rubber band to keep the pads in.

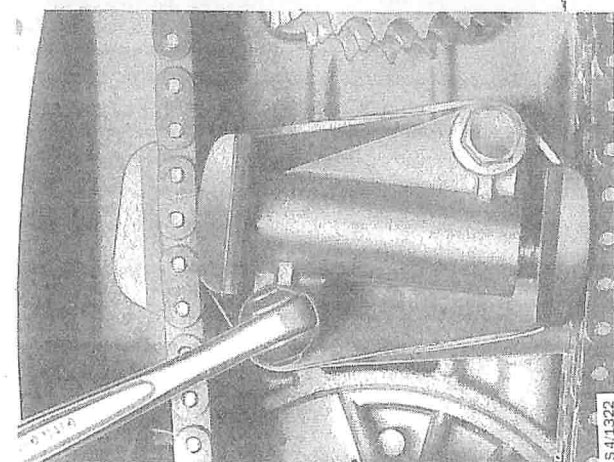

471-4 Dismantling and assembly

- 11 Remove the circlip in front of the upper chain sprocket bearing.

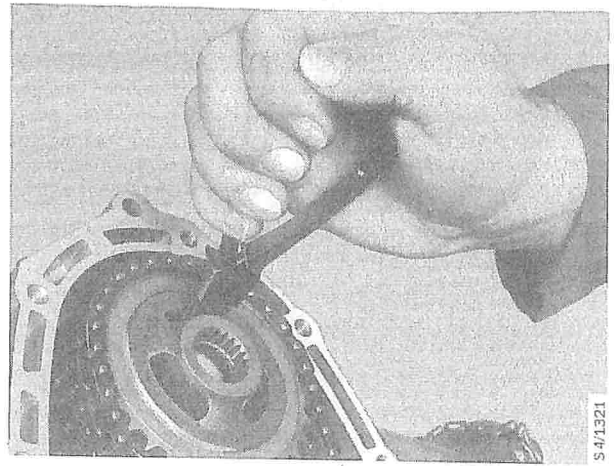

- 12 Remove both sprockets and chains simultaneously. Sliding hammer 83 90 270 and sleeve 87 90 891 may be needed to remove the sprockets.

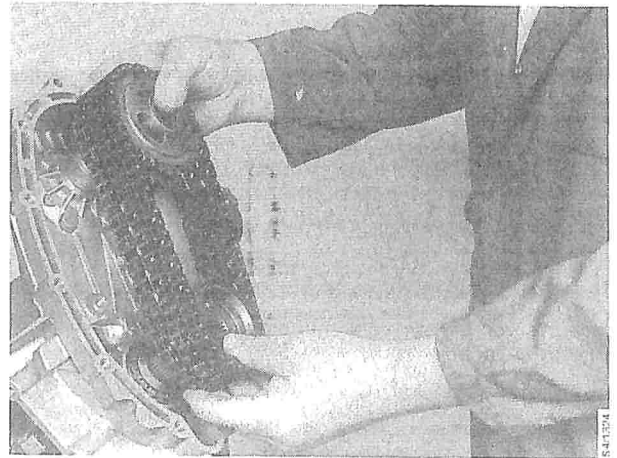
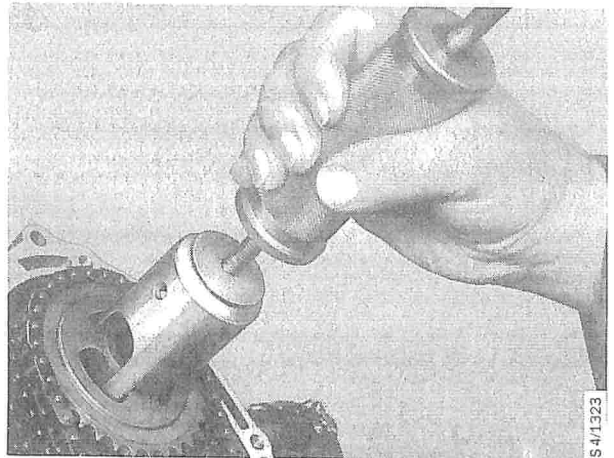

- 13 Move the layshaft drive gearwheel out of mesh by first removing the circlip and then moving the sleeve towards the gearwheel.

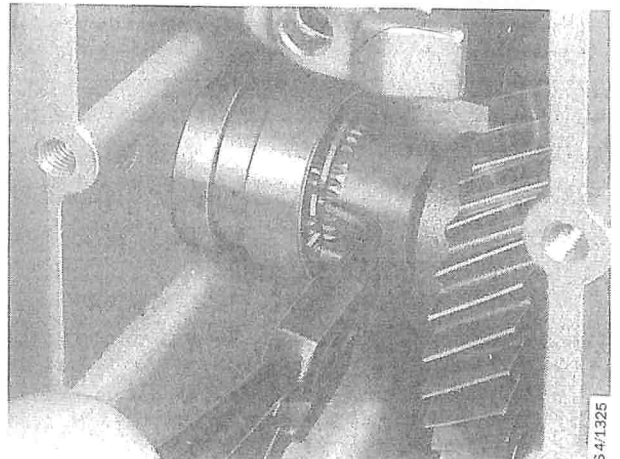

- 14 Remove the locking plate. Use a drift from the primary chaincase side to tap out the layshaft so that the layshaft drive gearwheel can be removed to the side, together with the sleeve and circlip.

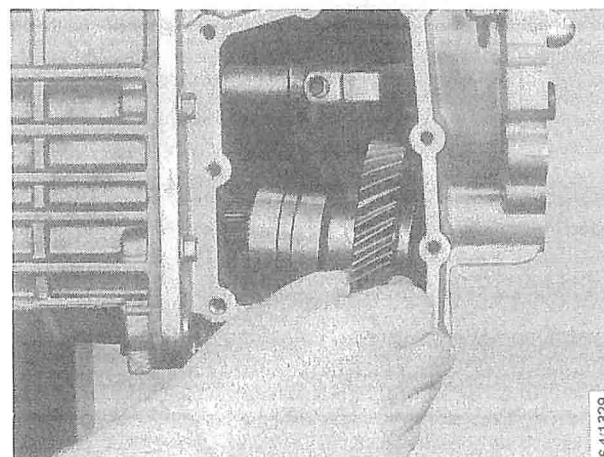
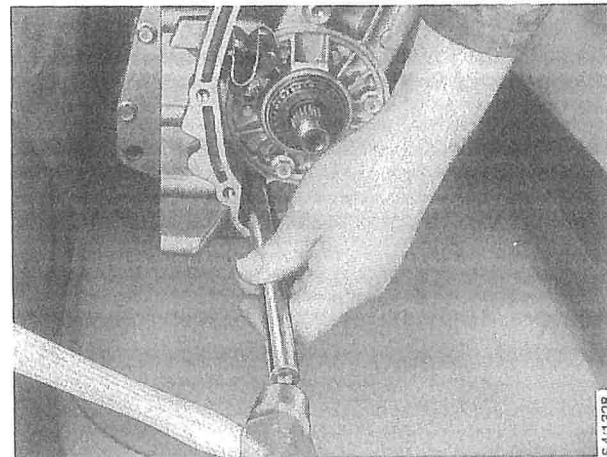
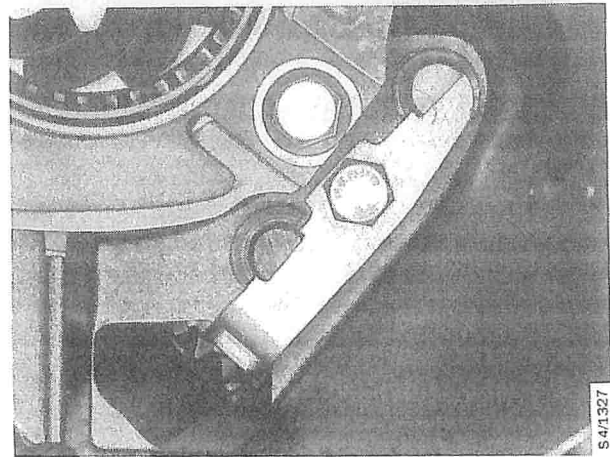
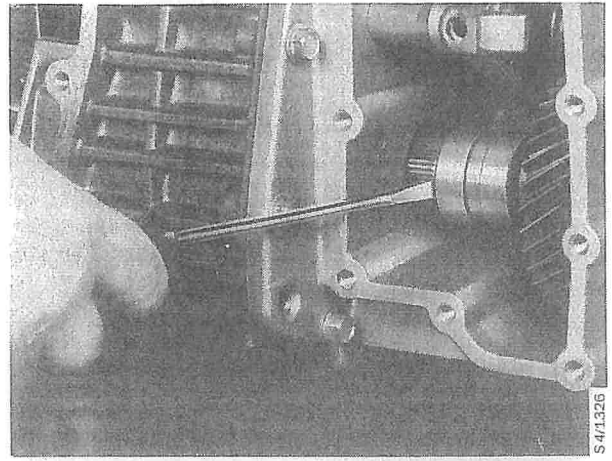

471-6 Dismantling and assembly

- 15 Remove the bolts for the input shaft bearing housing, thus releasing the front oil catcher. Then use sliding hammer 83 90 270 and adapter 87 90 917 to remove the bearing housing.

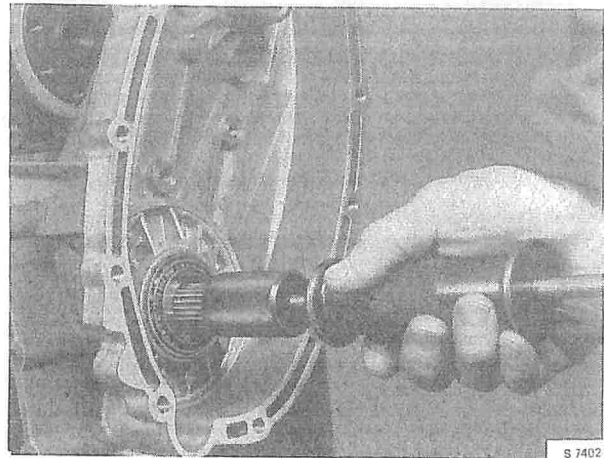
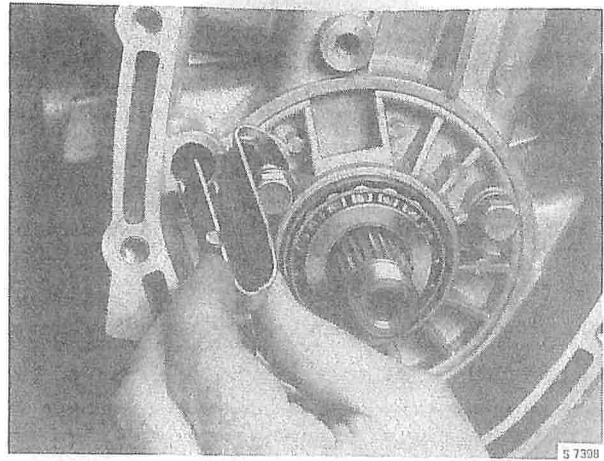

- 16 Swng out the 5th selector fork and remove the synchromesh sleeve.

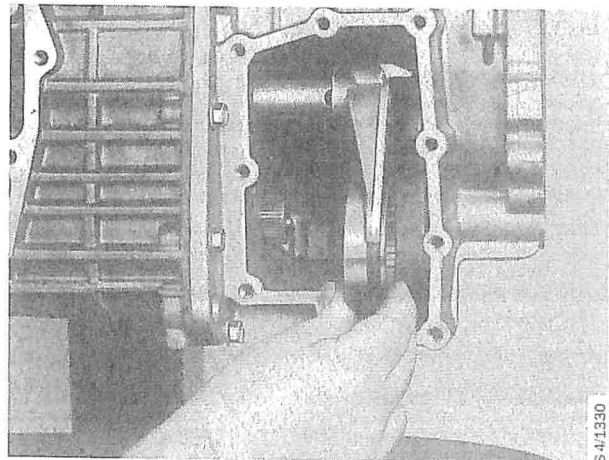

- 17 Use tool 83 90 049 to remove the reverse gear shaft.

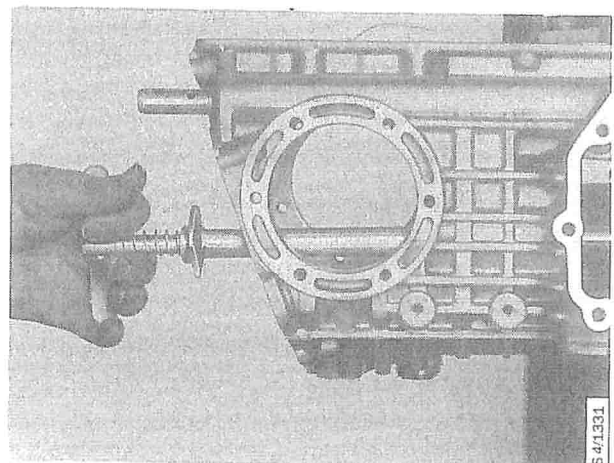

Remove the reverse gear by tilting out the left-hand end first.

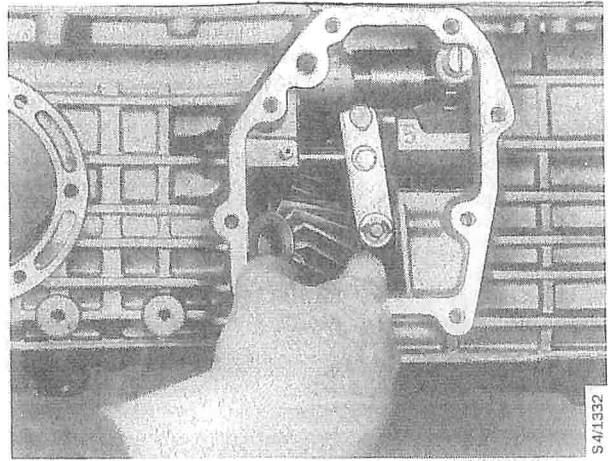

- 18 Fit locking tool 87 90 503 and release the nut for the 5th gear synchromesh hub. Remove the hub and sleeve.

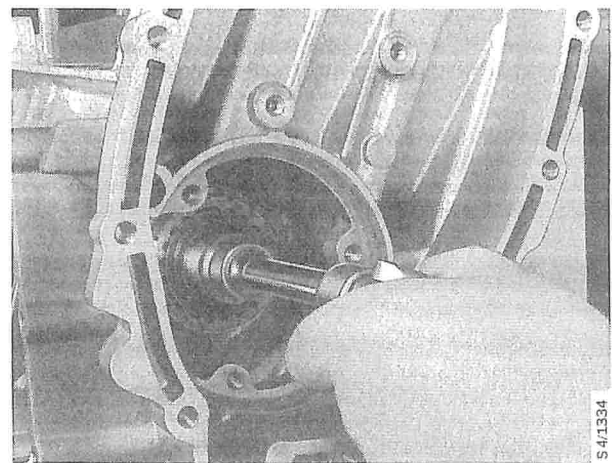
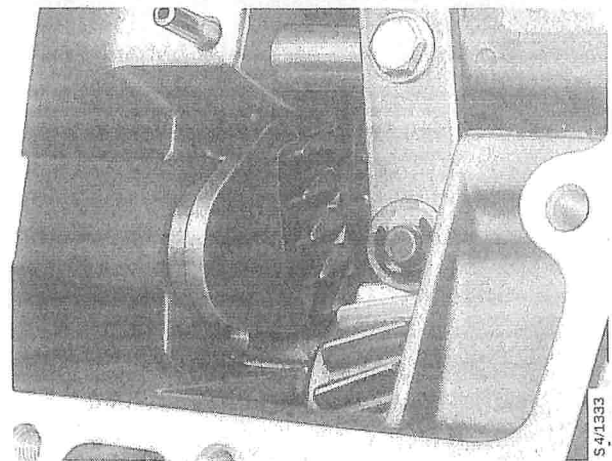

- 19 Remove tool 87 90 503.

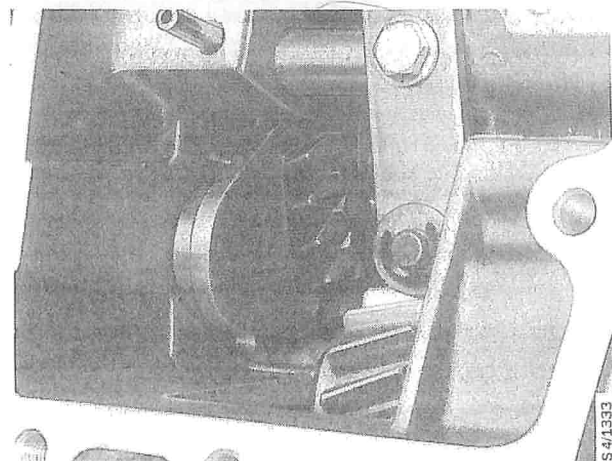

471-8 Dismantling and assembly

- 20 Remove all primary chaincase bolts and tap in the tubular dowels so that the chaincase can be separated from the gearcase. Remove any burrs around the hole in the shaft for 5th speed selector fork so that the hole in the gearcase will not be damaged. The 5th gear selector fork will remain in the chaincase and can be removed when the chaincase is removed.

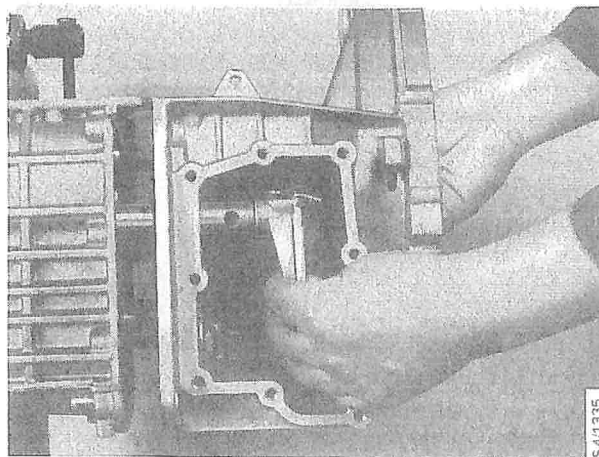

- 21 Remove the layshaft and the layshaft pinion set. Make sure that the bearing in the layshaft gearwheel remains in place.

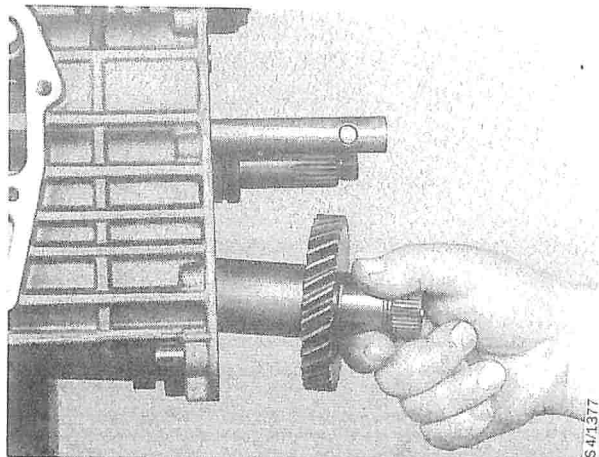

- 22 Remove the 5th gear actuator. Remove the shaft for the selectors and actuators.

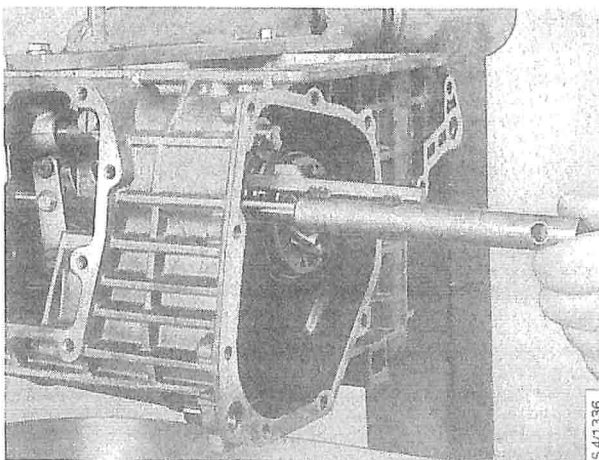

The actuator for reverse gear together with the shaft for 5th and reverse gear may be left in the gearcase.

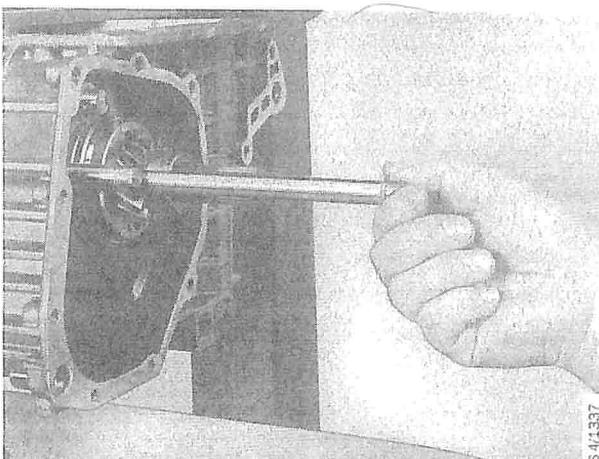

- 23 Remove the four bolts for the output shaft bearing housing. Fit tool 87 90 511 and press out the output shaft. Save the pinion, sleeves, washers and shims.

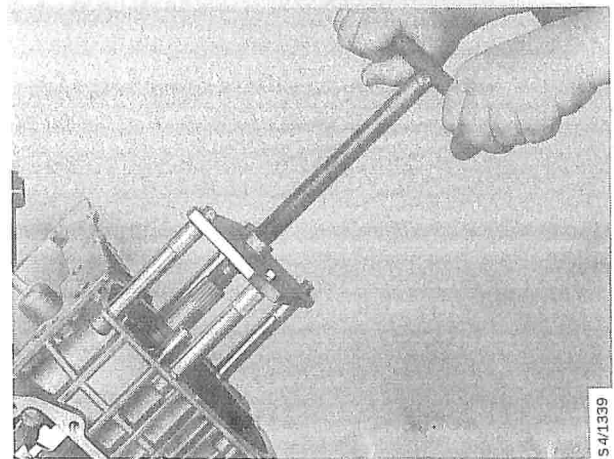
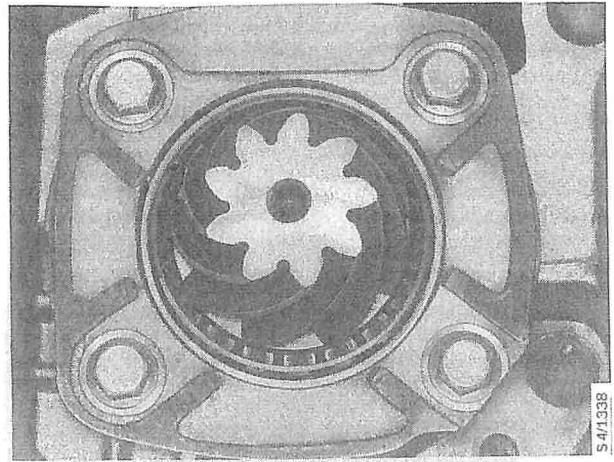

To assemble

After removing the part that needs attention, remove any gasket remnants and sealing compound from the covers and joint faces. Inspect the gearcase and all dismantled parts and wash them in paraffin (kerosine) or the like. Then grease and oil the parts with the lubricants listed in the specification.

To adjust the differential support bearings.

- 1 a Unless the support bearings have been changed, fit the differential together with the existing shims.
- b Fit the right-hand bearing housing without the universal joint driver.
- c Use drift 87 90 818 and a torque spanner to measure the rolling resistance (see figure). With new, lightly oiled bearings, the torque should be 1.8 - 2.8 Nm (1.3 - 2.1 lbf ft), and with bearings that have run more than 2000 km, it should be 0.8 - 1.3 Nm (0.59 - 0.95 lbf ft).
- d If the actual torque is outside the above ranges, the combination of shims must be altered. The table below gives particulars of the shims available.

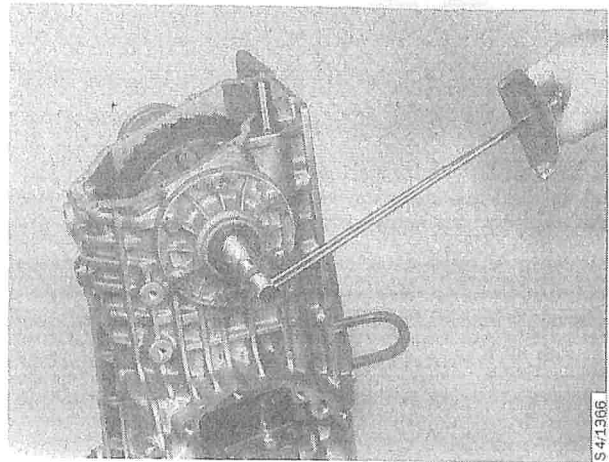

Location	Shims	
	Thickness, mm (in)	Part No.
Between differential bearing housing and gearcase	0,10 (0.003)	83 41 604
	0,15 (0.005)	83 41 612
	0,30 (0.012)	83 41 620
	0,50 (0.020)	83 41 638

- e Remove the bearing housings and differential. Fit the universal joint driver.

- 2 Fit the two guide pins (tool No. 87 90 438) into the gearcase. Then fit the shims, noting their locations, and fit the output shaft with

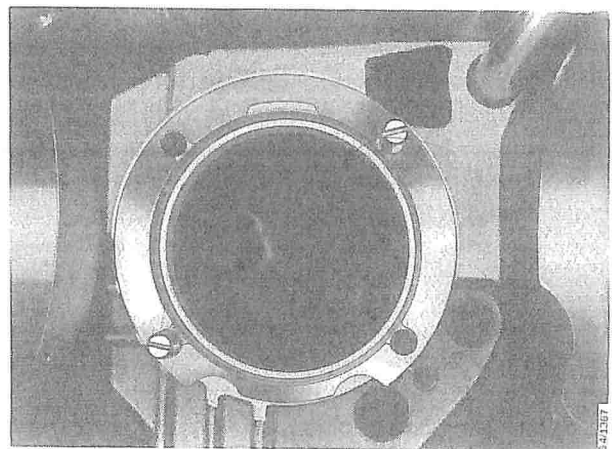

bearing housing. Fit two bolts and tighten them lightly. Then remove the guide pins and fit the remaining two bolts. Apply Loctite 242 to the bolt threads. Then tighten the four bolts to a torque of 23 - 28 Nm (17 - 21 lbf ft). Fit tool 83 90 155 to the differential bearing seats and check the pinion position (see figure). The value is stamped on the pinion.

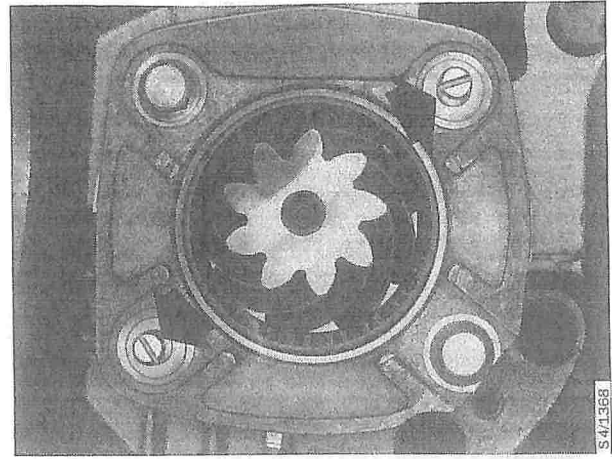

- 3 a Before fitting the reverse gearwheel to the output shaft, check the distance from the primary chaincase joint face down to the output shaft nut. The distance should be 195.0 - 195.1 mm (7.67 - 7.88 in). If the dimension is not within this range, use the shims on top of the nut and the reverse gearwheel to adjust the distance to the above value. The shim thicknesses available are 0.30, 0.40 and 0.50 mm (0.012, 0.016 and 0.019 in). If the position of the output shaft has not changed, the earlier shims can be refitted.

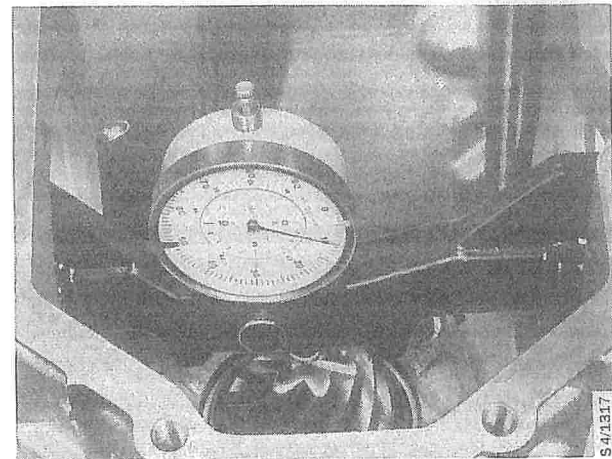

- 3 b The shimming procedure is as follows:

Fit tool 87 90 552 into the gearcase as shown in the figure, and use feeler gauges to measure the distance between the tool and nut. Fit shims corresponding to the thickness of the feeler gauges.

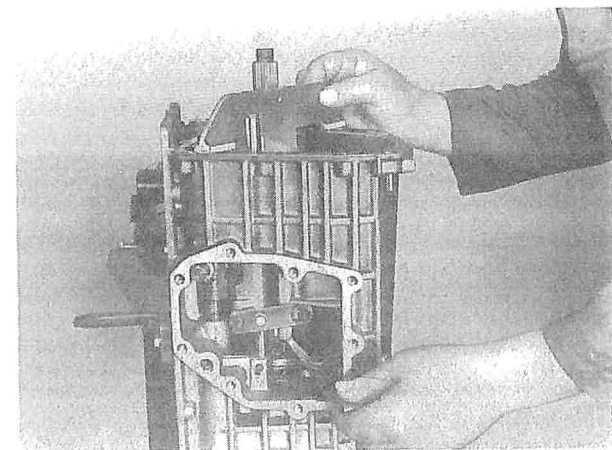

- 4 Use sleeve 83 90 148 to fit the reverse gearwheel.
- 5 Fit 1st gearwheel onto the reverse gear bearing sleeve.

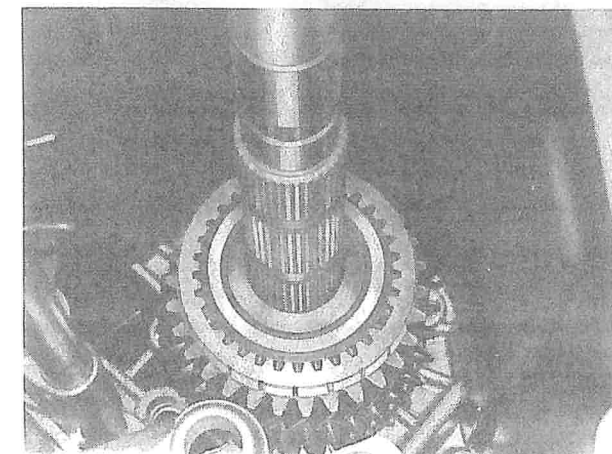

471-12 Dismantling and assembly

- 6 Fit 1st/2nd gear synchromesh hub. Fit 1st/2nd selector fork to 1st/2nd synchromesh sleeve and fit the assembly onto the synchromesh hub.

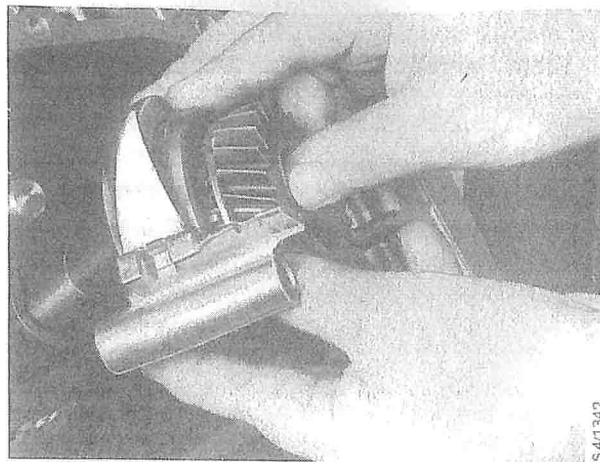

- 7 Use tool 83 90 148 to fit the sleeve for 2nd gearwheel and fit 2nd gearwheel onto the sleeve.

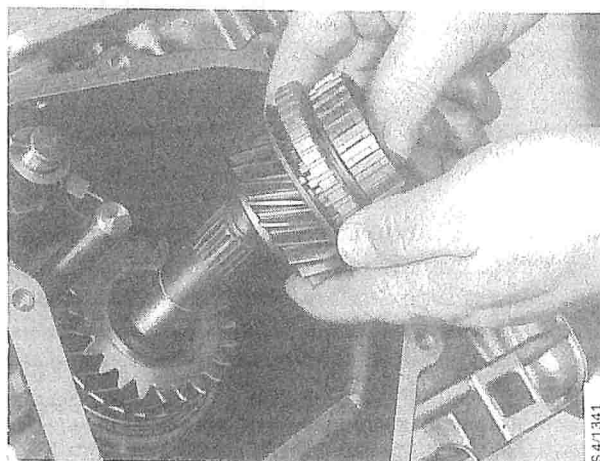

- 8 Use tool 83 90 148 to fit the sleeve for 3rd gearwheel and fit 3rd gearwheel onto its sleeve.

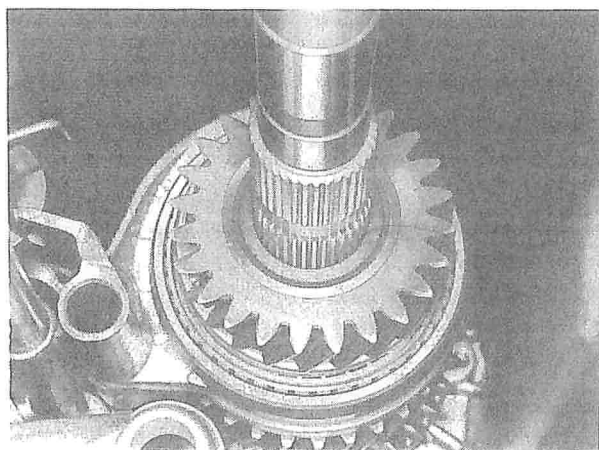

Note

A number of 3rd gearwheels of gearboxes between the following serial numbers

GM 108 967 - 109 854 and

GM 111 501 - 112 832

are fitted with two circlips as a result of a dimensional error. The error does not affect the performance or strength. The two circlips are fitted so that the 3rd guide ring will not come into contact with the layshaft pinion.

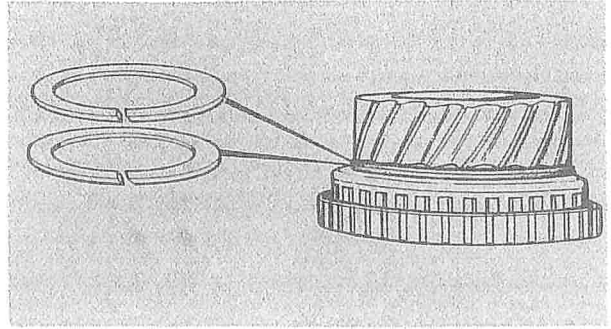

- 9 Fit the 3rd/4th gear synchromesh hub. Fit the 3rd/4th selector fork to the 3rd/4th synchromesh sleeve and fit these onto the synchromesh hub. Fit the sleeve for 4th gearwheel. Fit the gearwheel onto the sleeve. Fit the sleeve for the ball bearing.

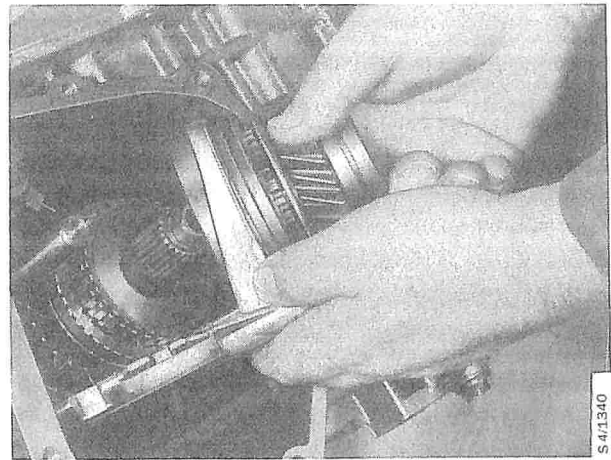

- 10 If the selector rod has been removed, refit it together with the guide pin of the selector interlock device.

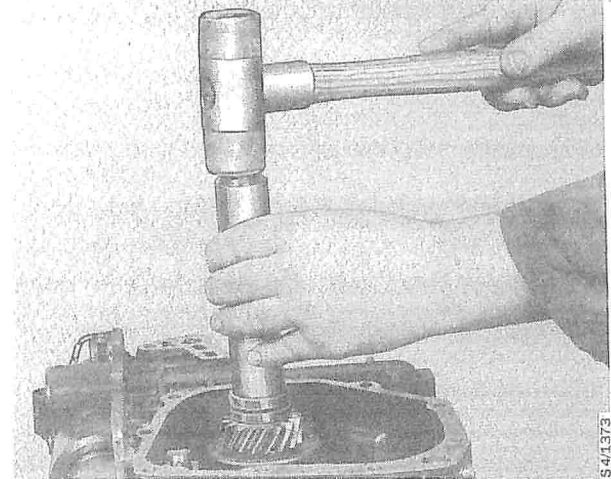

- 11 Move the synchromesh sleeves on the output shaft to the neutral position and fit the selector shafts for 1st/2nd and 3rd/4th selector forks.

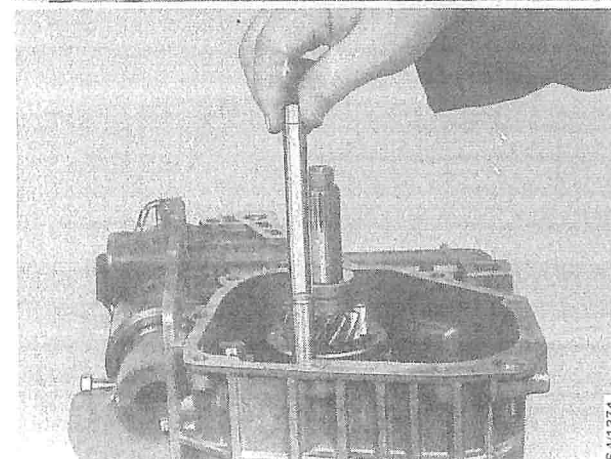

471-14 Dismantling and assembly

- 12 Fit the actuator for 5th gear to the reverse gear selector shaft.

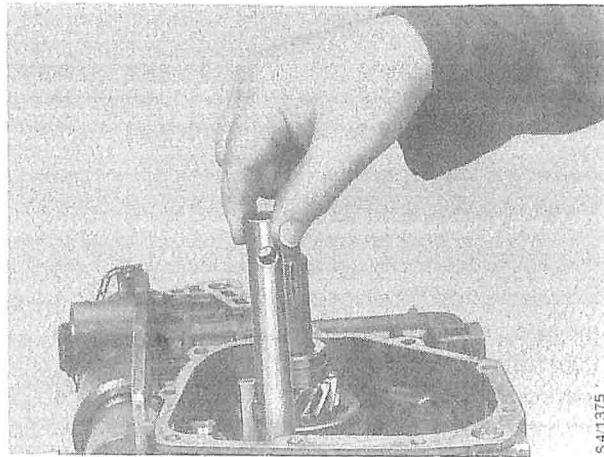

- 13 Fit the needle bearing into the rear layshaft pinion set and fit it into the gearcase.

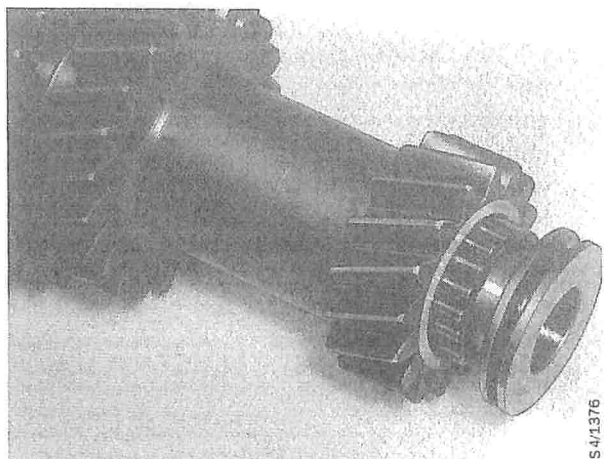

- 14 Fit the layshaft pinion set and the shaft and raise the pinion set to line it up with the shaft. Insert the shaft to hold the pinion set in position.

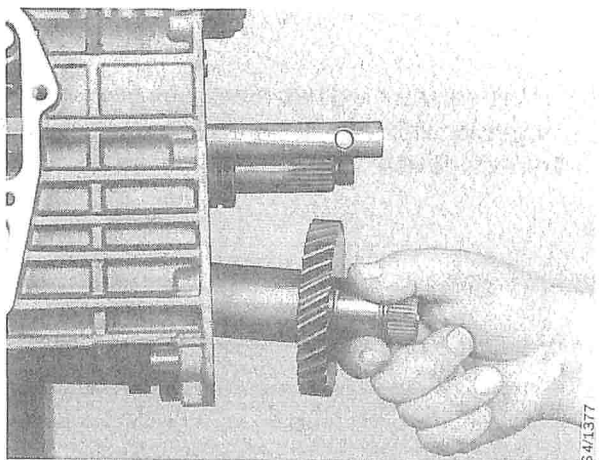

- 15 Apply Loctite 510 to the primary chaincase joint face and fit the chaincase to the gearcase. Tap in the tubular dowels before fitting the bolts.

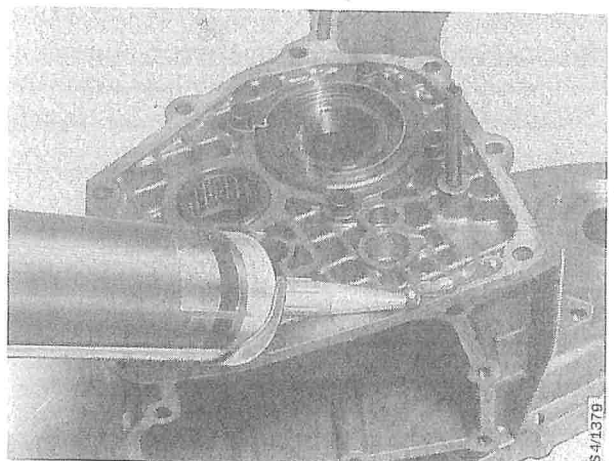

Make sure that the tubular dowel on the inner side of the chaincase fits between the spring ends of the selector rod. Remember that the 5th gear selector fork must be fitted now.

Tightening torque:

23 - 28 Nm (17 - 21 lbf ft)

Fit the spacer sleeve to the output shaft. Fit the 5th gear synchroneshub.

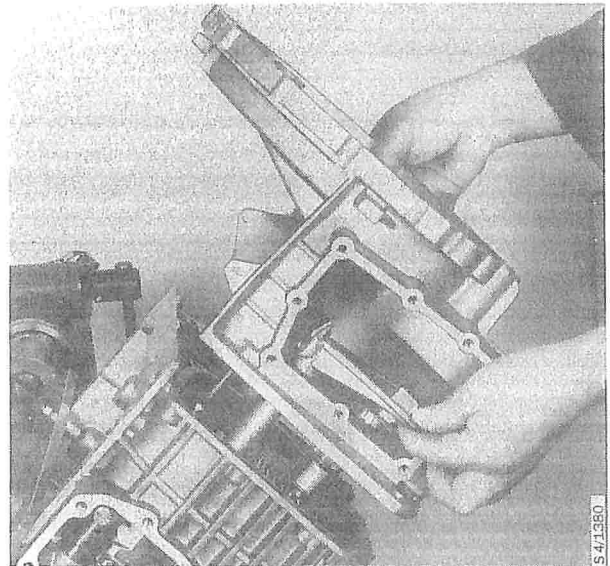

- 16 Fit locking tool 87 90 503 to the reverse gearwheel.

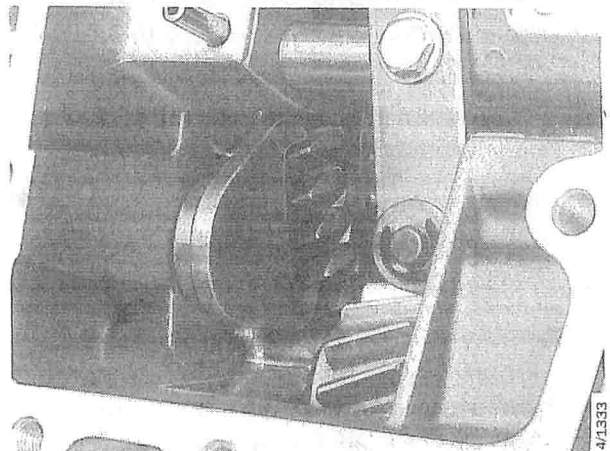

Tighten the input shaft nut to a torque of 50 ± 10 Nm (37 ± 7 lbf ft).

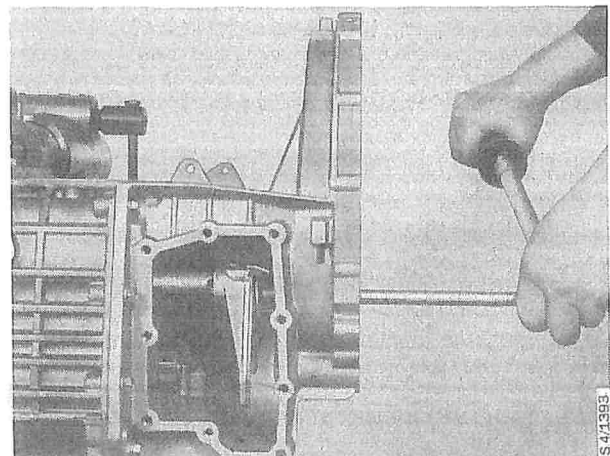

Lock the nut by peening over its flange into the holes in the hub. Use a drift with a rounded nose. Remove locking tool 87 90 503.

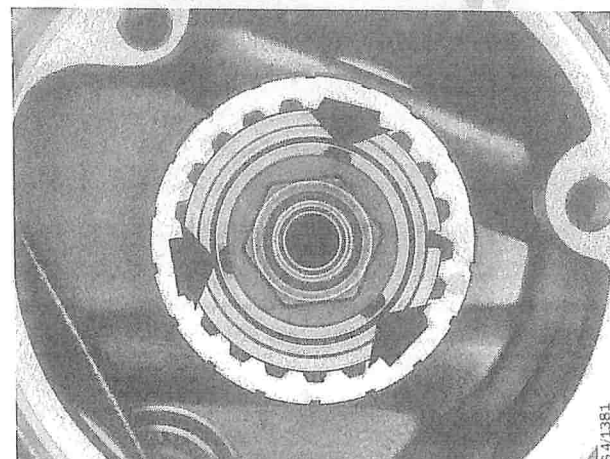

- 17 Fit 5th gear synchromesh sleeve into the selector fork.

Note

Before fitting, check the bearing preload (see page 471-31).

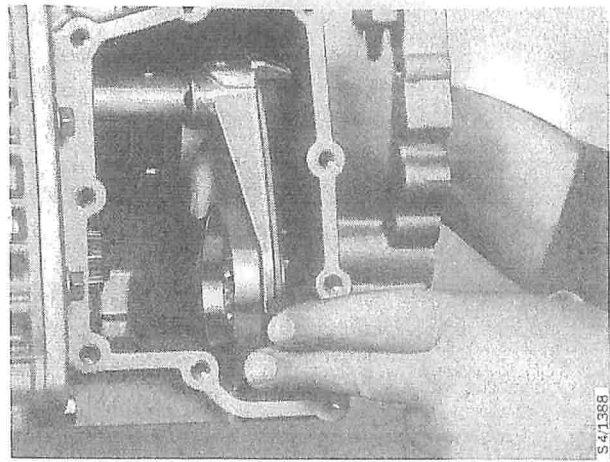

- 18 Fit the input shaft together with the bearing housing, oil catcher and connecting pipe. Use two guide pins 87 90 438 for alignment. Push in the bearing housing so that the shaft comes into engagement with the sleeve. Use the bolts to press in the bearing housing.

Fit the bolts and tighten to a torque of 23 - 28 Nm (17 - 21 lbf ft).

- 19 Fit the rollers and the inner bearing race into the 5th gearwheel.

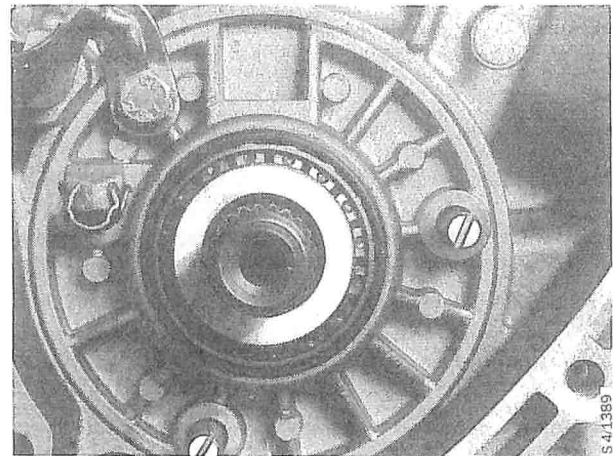

- 20 Fit the layshaft drive gearwheel complete with sleeve, circlip and bearing rollers. Insert the shaft for the layshaft all the way in.

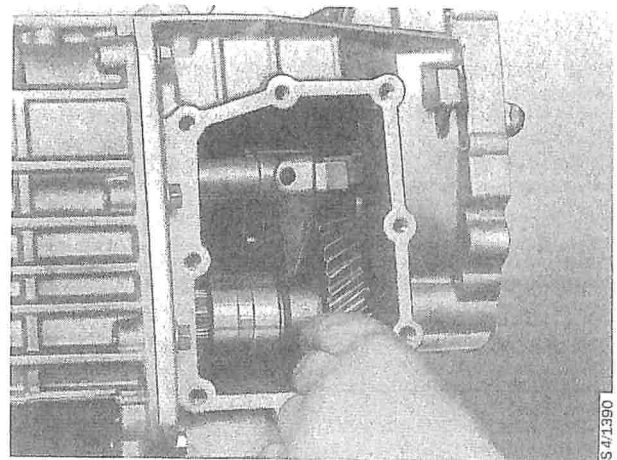

- 21 Slide the sleeve over and fit the circlip into the groove.

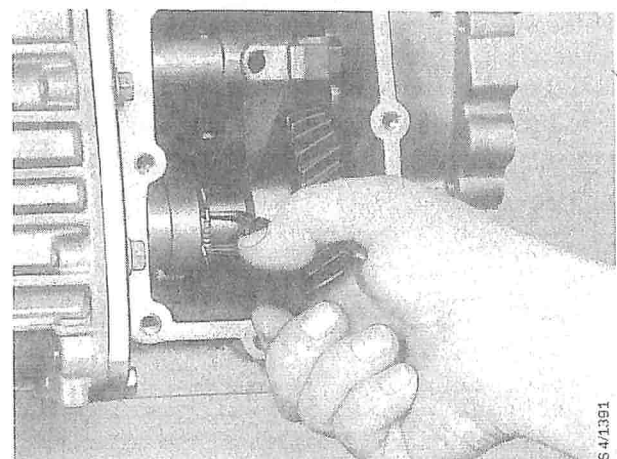

- 22 Then use a drift to push the shaft of the layshaft pinion set into the locking position. If necessary, use tool 83 90 049 to turn the shaft.
- 23 Fit the reverse gear and shaft. Make sure that the pivoted segment of the reverse gear lever engages into the groove in the reverse gear. Use tool 83 90 049 to adjust the shaft to the proper locking position.

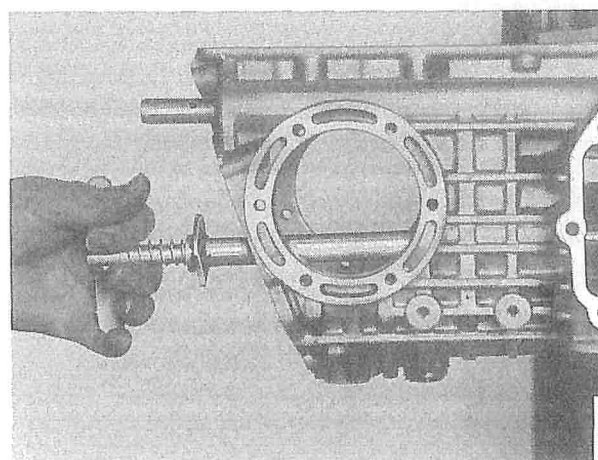
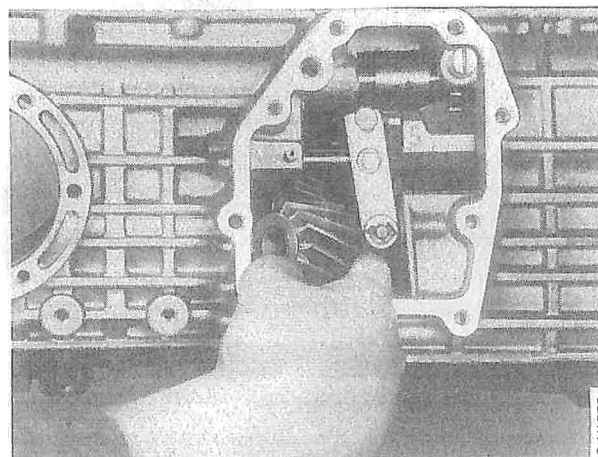

- 24 Apply Loctite 242 to the locking plate bolt.

Tightening torque:
23 - 28 Nm (17 - 21 lbf ft).

Fit the locking plate to secure the shafts.

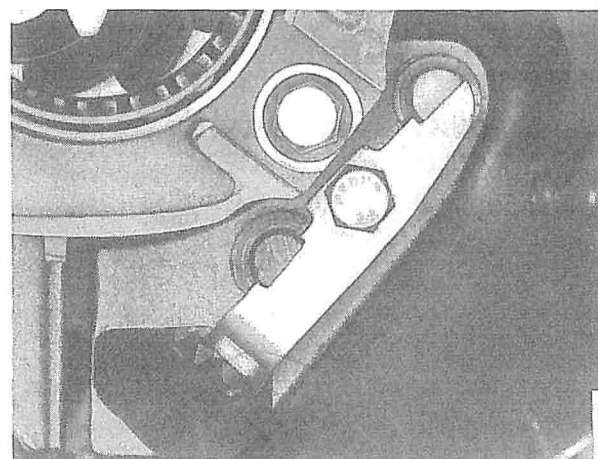

471-18 Dismantling and assembly

- 25 Fit the primary drive chains and sprockets. Check that the locking holes of the bottom sprocket face out towards the nut side.

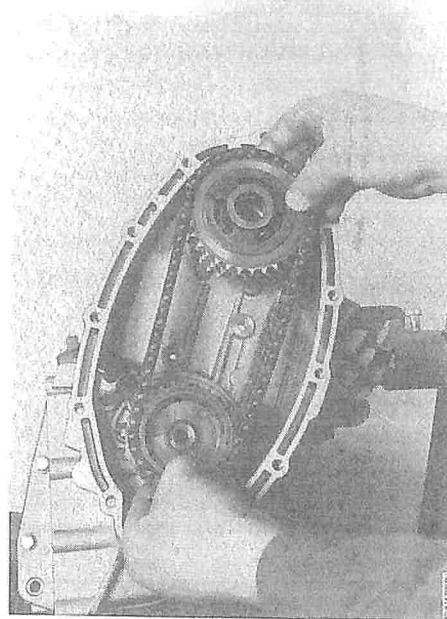

- 26 Fit the chain tensioner. Apply Loctite 45 to the mounting bolts and tighten them to a torque of 23 - 28 Nm (17 - 21 lbf ft).

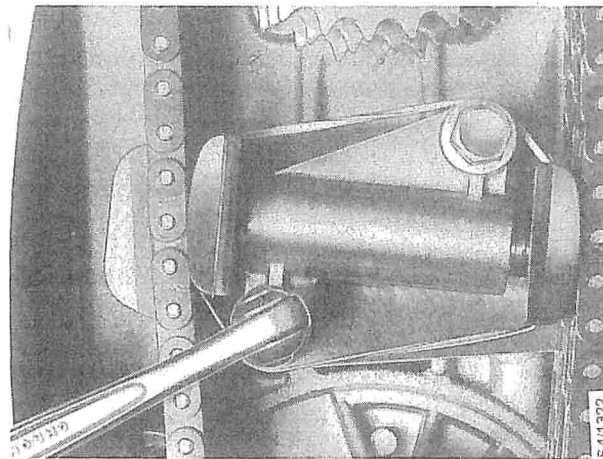

- 27 Fit the nut to the input shaft. Before tightening, engage reverse gear and 5th gear simultaneously to lock the input shaft.

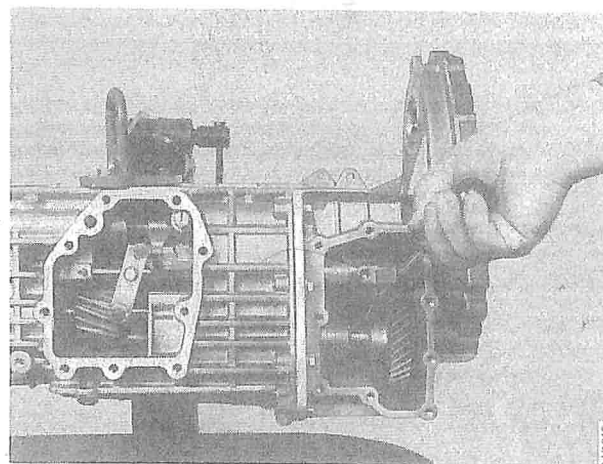

Then tighten the nut to the specified torque of 100 ± 10 Nm (74 ± 7.4 lbf ft). Peen the nut flange into the holes. Use a drift with a rounded nose.

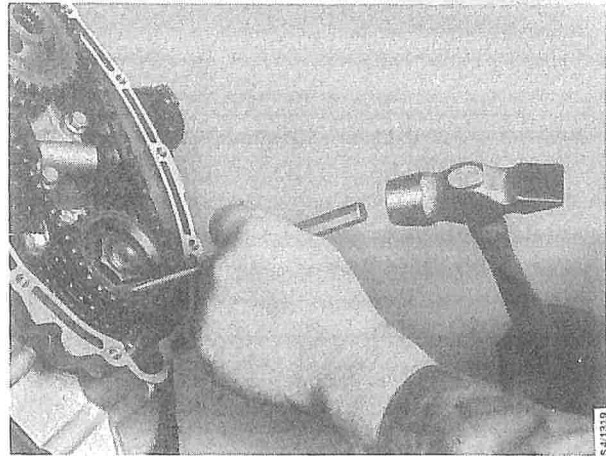
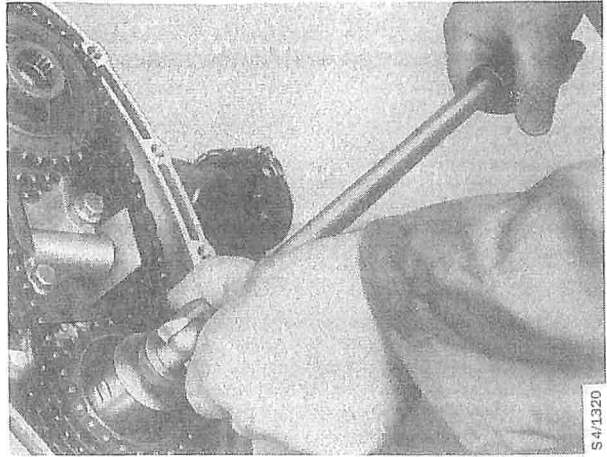

28 Fit the locking pin into the actuator of 5th selector fork. Test the gear positions.

29 Fit the differential unit (see section 473).

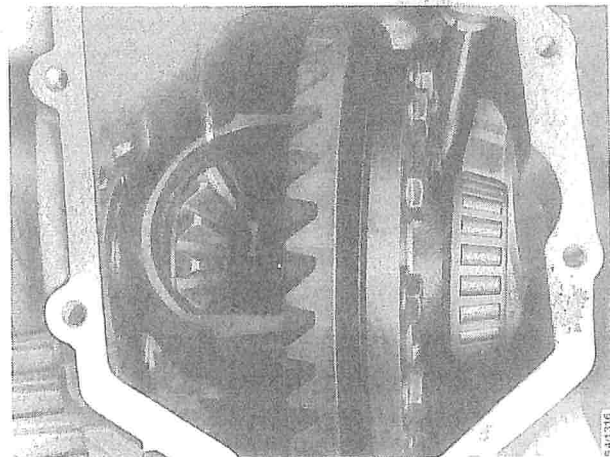

- 30 Check the shaft seals in the differential bearing housings, and fit new seals if necessary.

Tightening torque:

23 - 28 Nm (17 - 21 lbf ft).

Apply thread sealing compound to the threads.

Adjust the crown wheel backlash so that, if the bearings have been in service less than 10 000 km, it will be 0.17 ± 0.05 mm (0.007 ± 0.002 in). Measure at four points.

Adjust as described in section 473.

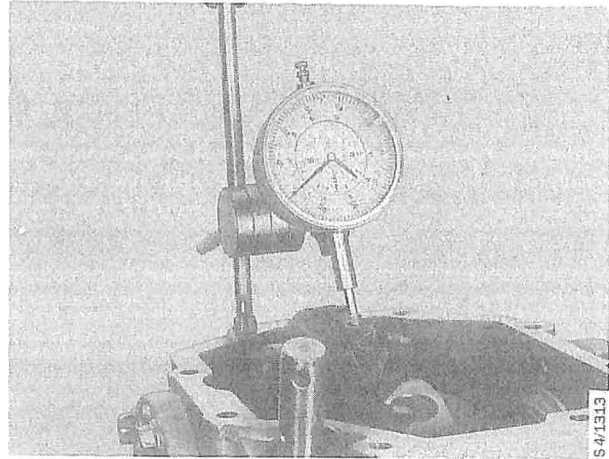

- 31 Fit the covers and gaskets for the final drive unit, primary chaincase and gearcase side cover. Fit the speedometer drive.
- 32 Pour 0.3 litres of oil into the primary chaincase and 2.7 litres into the gearcase.

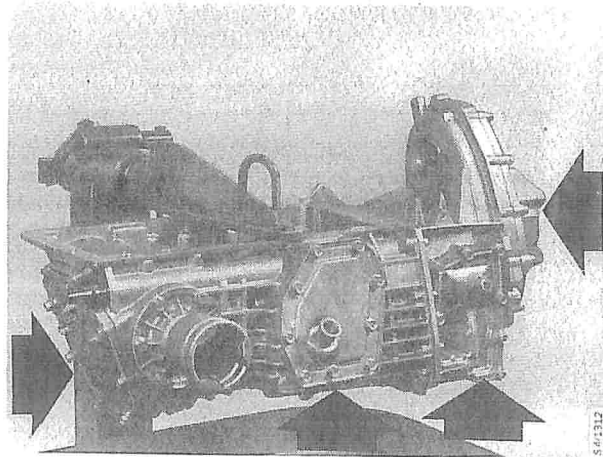

Output shaft of 5-speed gear-box

To remove and dismantle

For removing the output shaft, follow the description for dismantling the gearbox up to the point where the output shaft has been removed. Then continue dismantling as follows:

- 1 Secure fixture 87 90 446 in a vice and place the output shaft in the fixture. Use spanner 87 90 453 to release the nut.

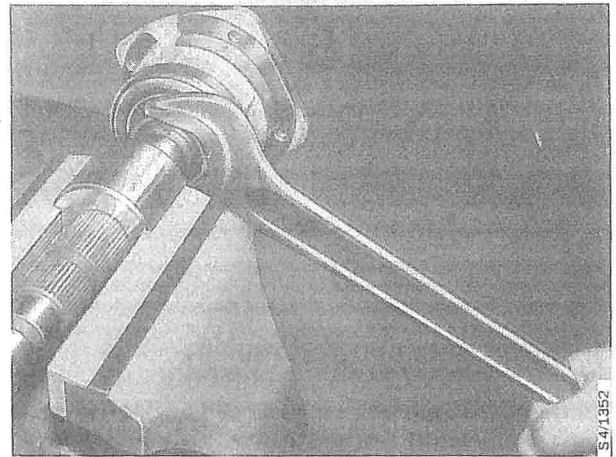

- 2 Set up the bearing housing in a press and press the shaft out of the bearing housing. Remove the spacer sleeve.

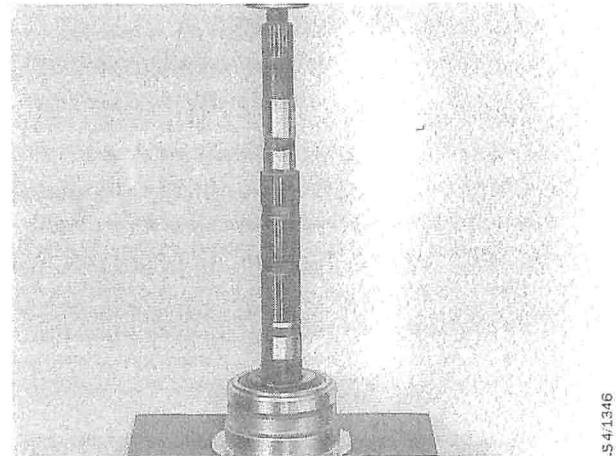

- 3 Then use tools 87 90 636 and 87 90 651 to press off the rear roller bearing. Turn the shaft from time to time and check that the tops of the teeth are clear of the tool.

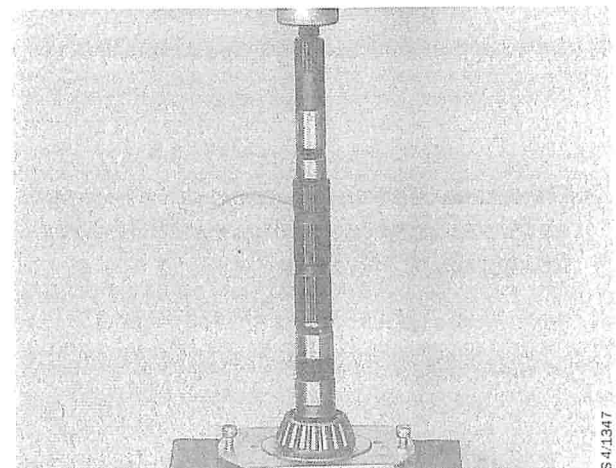

- 4 Use tools 83 90 098, 83 90 106 and 83 90 148 to press the outer races of the taper roller bearings out of the bearing housing (see figure).

To assemble and refit

After the relevant part has been removed, inspect all dismantled parts and wash them with paraffin (kerosine) or the like. Then proceed as follows to re-assemble:

Note

Oil the bearings before assembly.

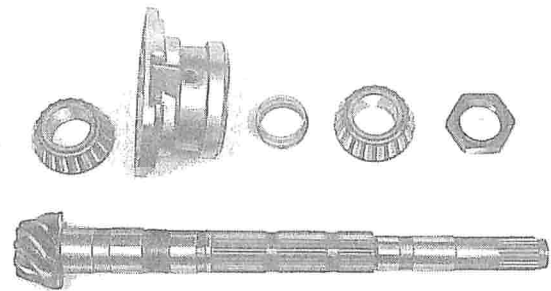
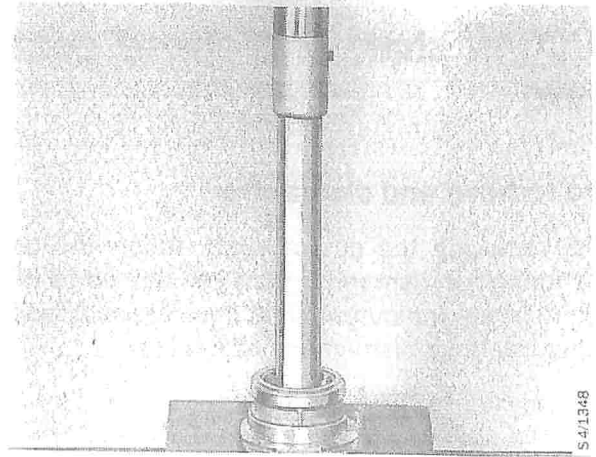

Output shaft with bearing, bearing housing and spacer sleeve.

- 1 Use tool 87 91 964 and drift 83 90 189 to press the outer race of the taper roller bearing into the bearing housing nearest to the pinion. Use sleeve 87 90 461 and drift 83 90 189 for the outer race of the other bearing.

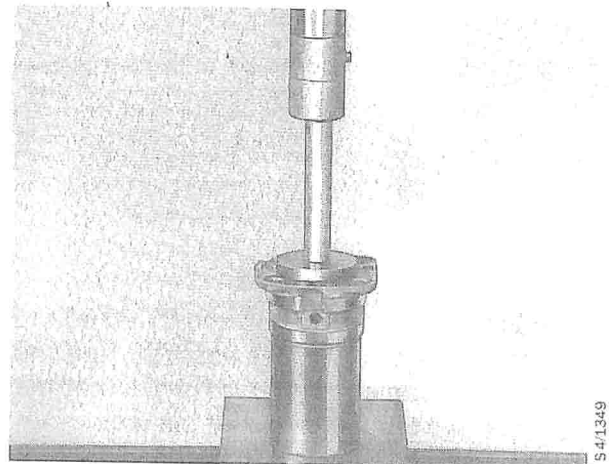

- 2 Press the roller bearing nearest to the pinion as far as it will go. Use fixture 87 90 636 and fitting ring 87 91 972.

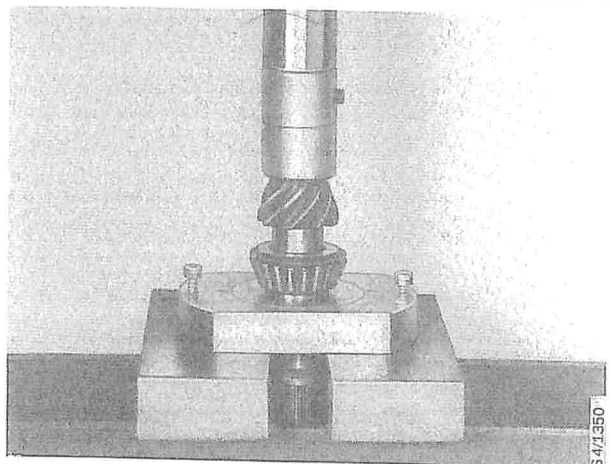

- 3 Fit a new spacer to the shaft.
- 4 Fit the bearing housing.
- 5 Fit the front roller bearing.
- 6 Set up the shaft in the press (see figure). Use fixture 87 90 636 and fitting ring 87 91 972 and press slowly, at the same time turning the bearing housing. Continue pressing until resistance is felt.

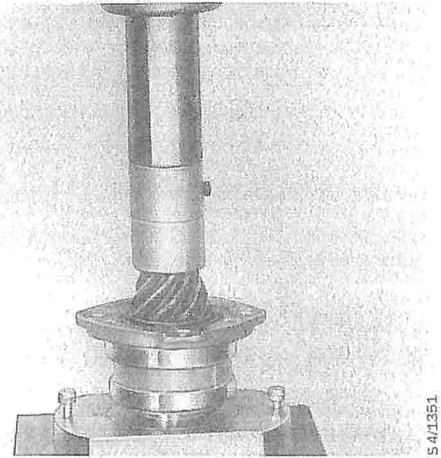

- 7 Apply Loctite 270 to the threads and fit a new nut. Set up the shaft in a vice in tool 87 90 446. Use spanner 87 90 453 to tighten the nut until the correct rolling torque is obtained.

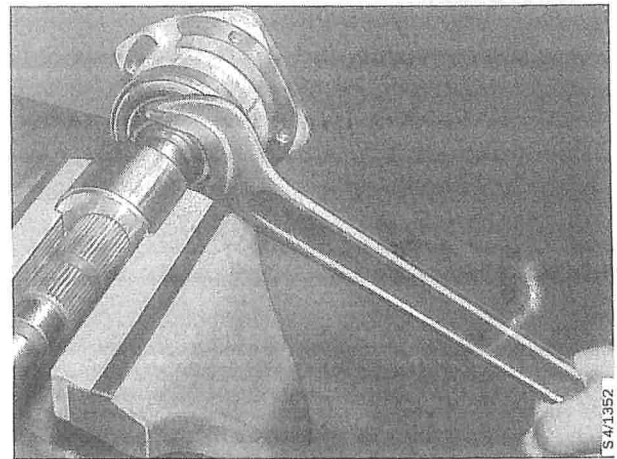

Use a torque spanner to measure the rolling torque. Oil the bearing lightly and preload as follows: New bearings to a torque of 2.5 ± 0.5 Nm (1.8 ± 0.4 lbf ft), and bearings that have been in service for more than 2000 km to 1.3 ± 0.5 Nm (1.0 ± 0.4 lbf ft).

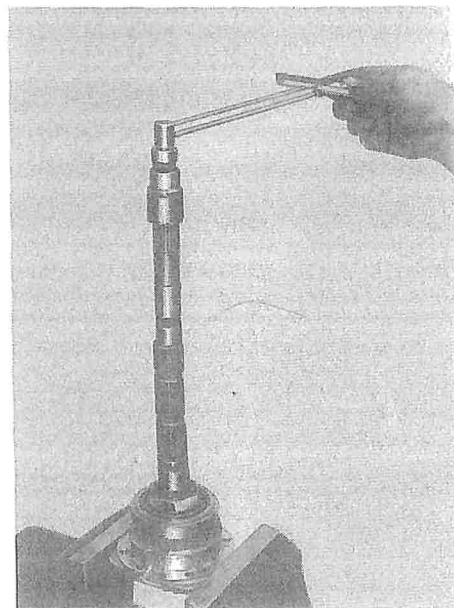

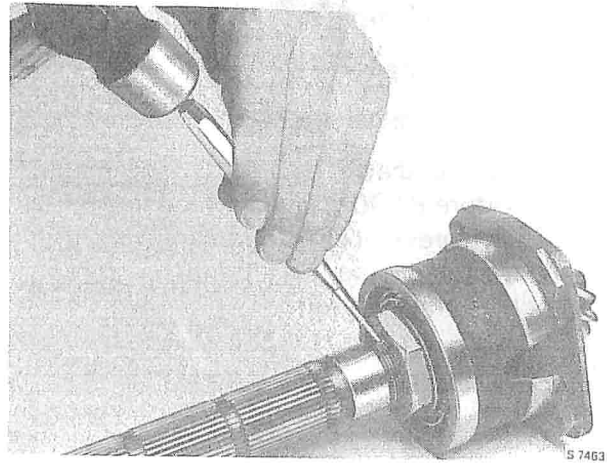

Use a drift to peen over the nut.

- 8 Fit two guide pins 87 90 438 into the gearcase. Then fit the shims, fit the output shaft with the bearing housing, and fit two bolts. Tighten the two bolts lightly, remove the guide pins and fit the other two bolts. Then tighten the four bolts to a torque of 23 - 28 Nm (17 - 21 lbf ft). Apply Loctite locking compound to the bolts.

Primary chaincase

The primary chaincase is removed in conjunction with the removal of the gearbox. When removed from the gearbox, the primary chaincase contains the following parts: A. Ball bearing, B. Needle bearing, C. Clutch shaft seal, D. Level control ball valve and tubular dowel. Remove these parts as follows:

Ball bearing

To remove

- 1 Remove the four Torx screws and remove the ball bearing retainer.

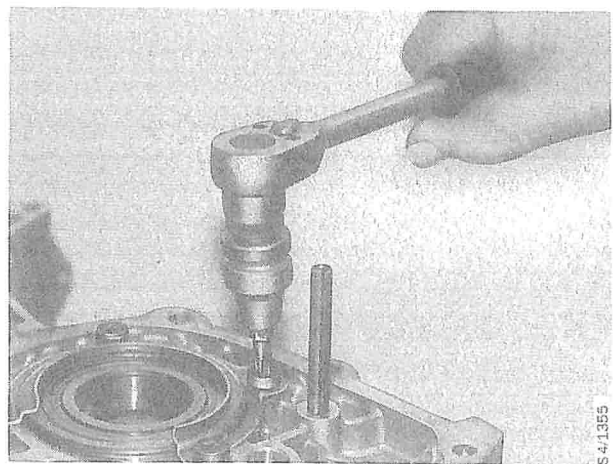

- 2 Use drift 83 90 106 and sleeve 83 90 148 to press out the ball bearing.

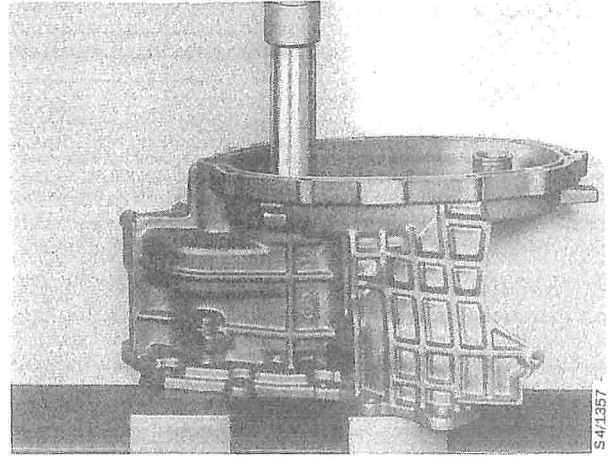

To fit

- 1 Use tool 83 90 114 to press the bearing into the primary chaincase.

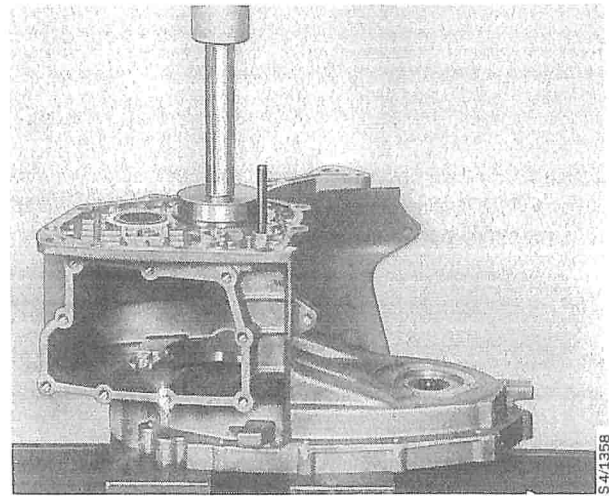

Fit the bearing retainer. Apply Loctite to the bolts and tighten them to a torque of 9.5 - 14 Nm (6.3 - 10.0 lbf ft).

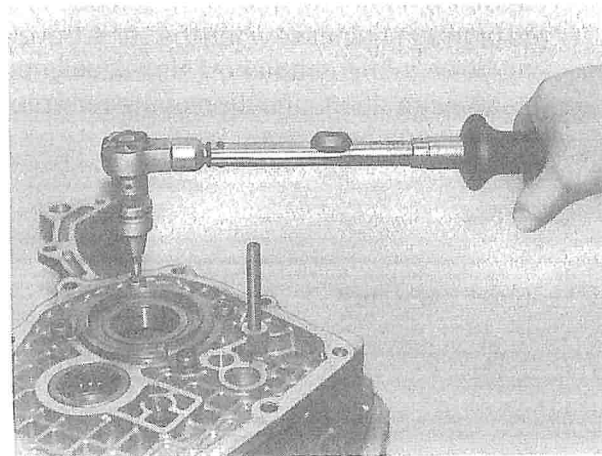

Needle bearing

To remove and refit

- 1 Use tool 83 91 997 and a drift to remove the bearing.

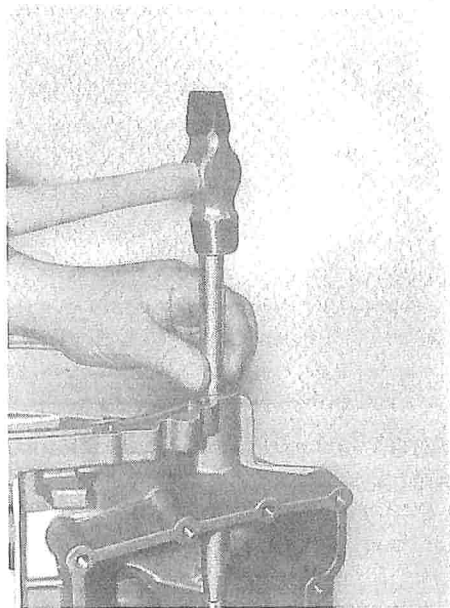

- 2 Use tool 83 91 997 and drift 78 41 067 in a press to press in the bearing.

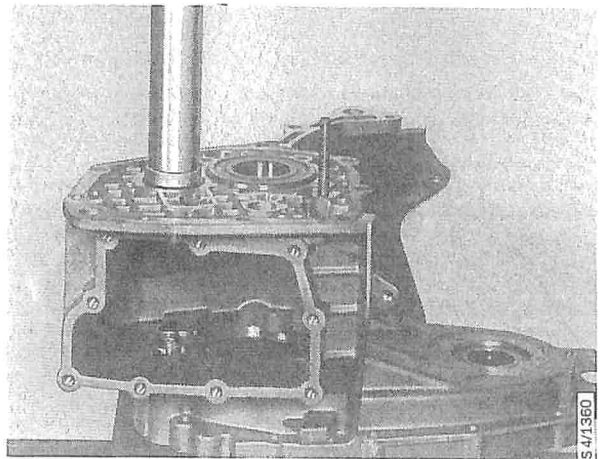

Ball valve

- 1 The level control ball valve should not be removed. Only check that the ball moves freely and seals against the seat.

The function of the ball valve is to prevent the oil from running from the gearcase into the primary chaincase when the car is travelling down a long gradient. This is designed to safeguard the lubrication of the differential unit and final drive.

Clutch shaft seal

To remove and refit

- 1 Use a screwdriver to remove the clutch shaft seal.

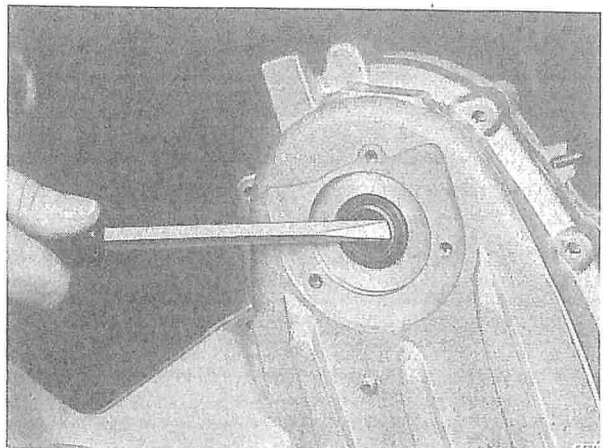

- 2 Use drift 83 91 997 to fit the clutch shaft seal. Grease the seal lip after fitting. For particulars of the grease, see the specification.

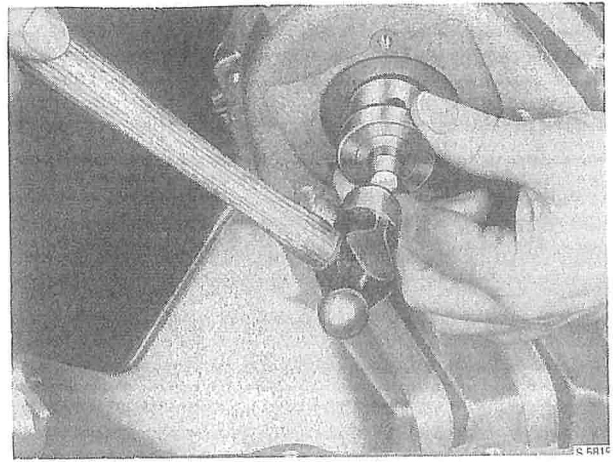

Tubular dowel

To remove the tubular dowel from the primary chaincase, grip it in a vice and turn the chaincase back and forth. Fit the dowel by hammering it in.

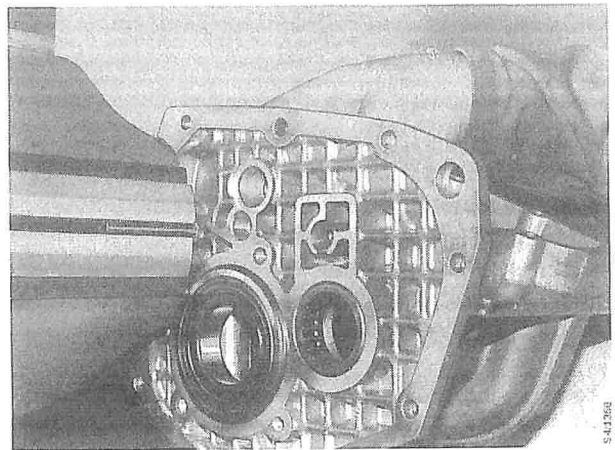

Primary chain drive

To dismantle

- 1 To dismantle the primary drive separately, remove the front cover from the primary chaincase. Then follow the instructions under "To dismantle the gearbox".
- 2 Remove the circlip for the bearing in the upper sprocket.



- 3 Use sleeve 87 90 891 to press the bearing out of the upper chain sprocket.

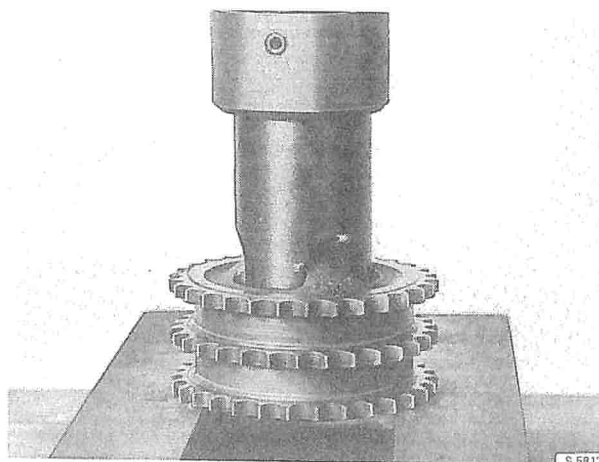

To assemble

Note

Fit the circlip for the outer race of the bearing with the chamfer facing outwards.

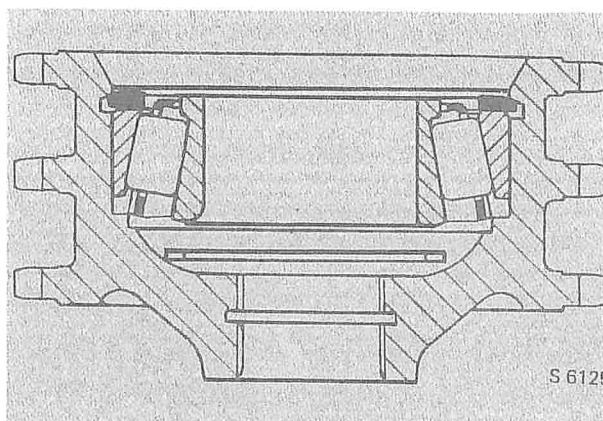

- 1 Fit the circlip into the upper sprocket and press the bearing into the sprocket (see figure). Use sleeve 87 90 859 and drift 88 90 312.
- 2 Fit the chains, sprockets and chain tensioner as described under "To assemble the gearbox".
- 3 Fill with oil.

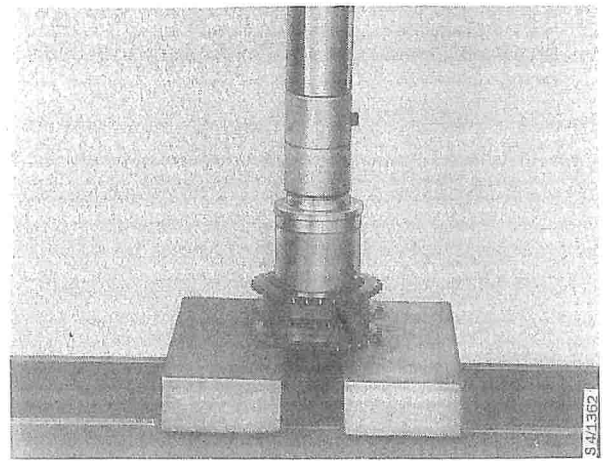

Input shaft bearing housing

To remove

- 1 Remove the oil catcher from the bearing housing and press out the input shaft. Save the front bearing, spacer and shims. Use dolly 83 90 098.

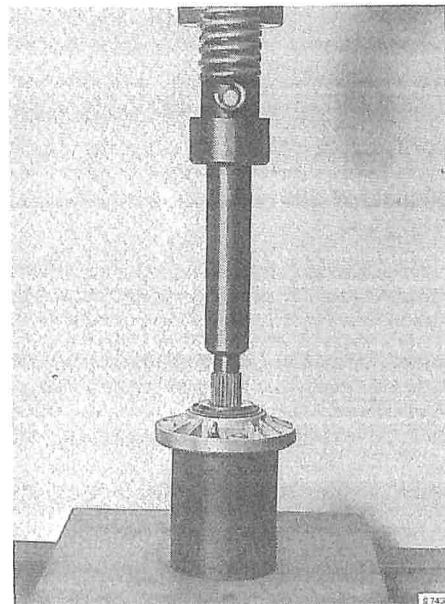

- 2 Take care not to damage the connecting pipe while pressing.

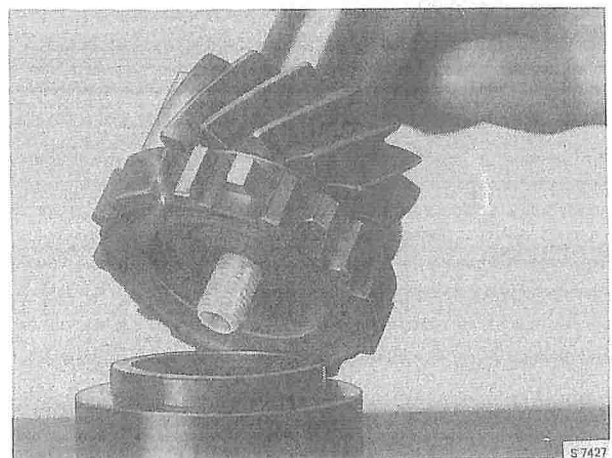

3 Press the rear roller bearing off the input shaft. Use fixture 87 90 636 and ring 87 90 933.

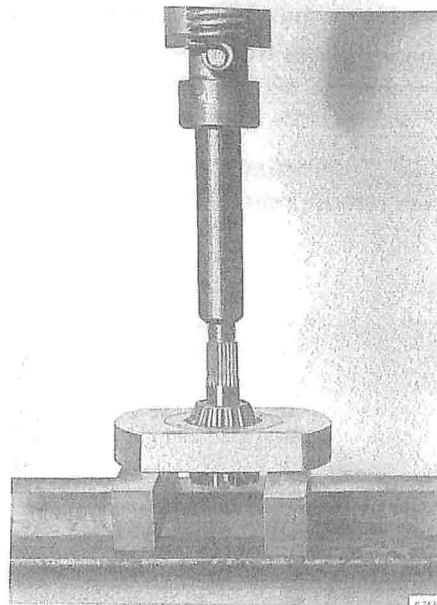

4 Use a drift to remove the bearing races from the housing. Use a suitable ring-shaped support.

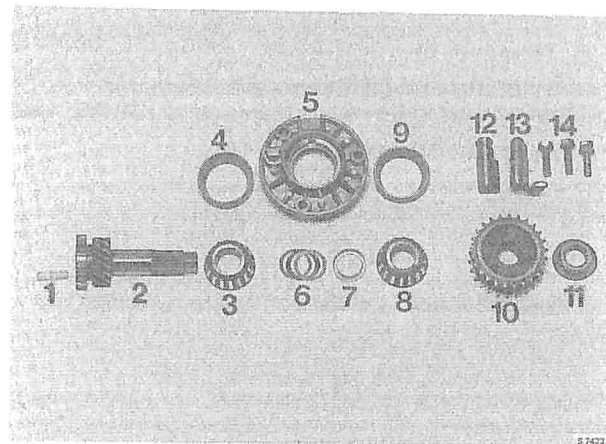

Input shaft bearing housing

- | | |
|-----------------------------------|----------------------|
| 1 Connecting pipe for lubrication | 8 Roller bearing |
| 2 Input shaft | 9 Bearing race |
| 3 Roller bearing | 10 Chain sprocket |
| 4 Bearing race | 11 Nut |
| 5 Bearing housing | 12 Rear oil catcher |
| 6 Shims | 13 Front oil catcher |
| 7 Spacer | 14 Bolts |

To assemble

1 Use drift 78 41 075 and a ring-shaped support to press the rear bearing onto the shaft. Remove the shims during pressing.

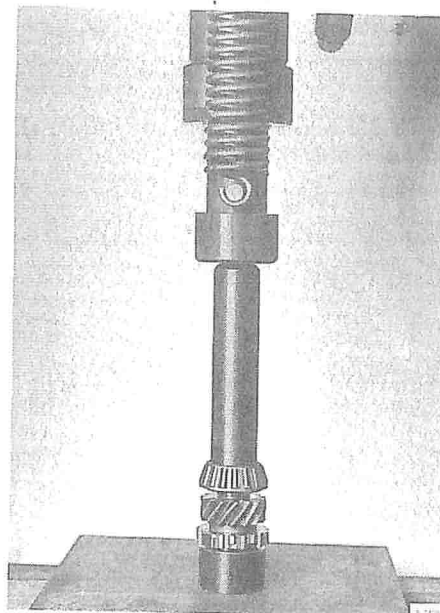

- 2 Press the bearing races into the bearing housing. Use tools 83 90 312, 83 90 189 and a ring-shaped support. When pressing in the inner bearing race, turn the tool so that the smaller radius is used. The bearing race will otherwise not bottom.
- 3 Fit the input shaft, shims, spacer and bearing into the bearing housing. Select shims and spacer of known size so that axial play will deliberately be obtained. Place the shims between the rear bearing and the spacer.
- 4 Oil the bearings and press them together with a force of 3 tons until they meet the spacer. Rotate the bearing housing while pressing against both the upper and lower bearings, 40 times in each direction, so that the rollers will be firmly in contact. Use drift 78 41 075 and a ring-shaped support to avoid damage to the connecting pipe.

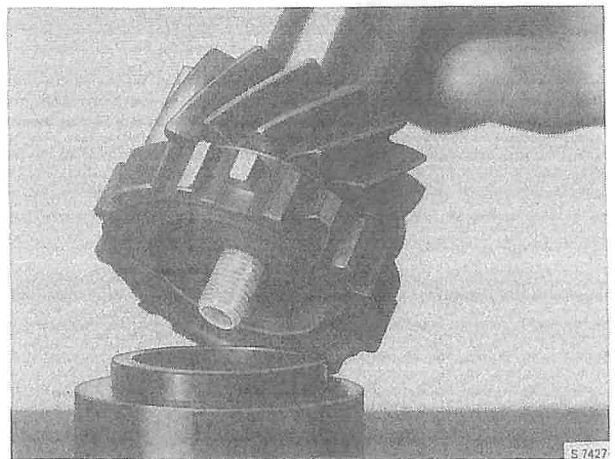
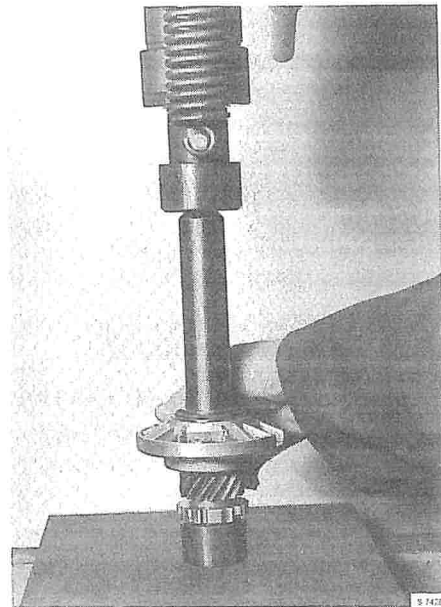
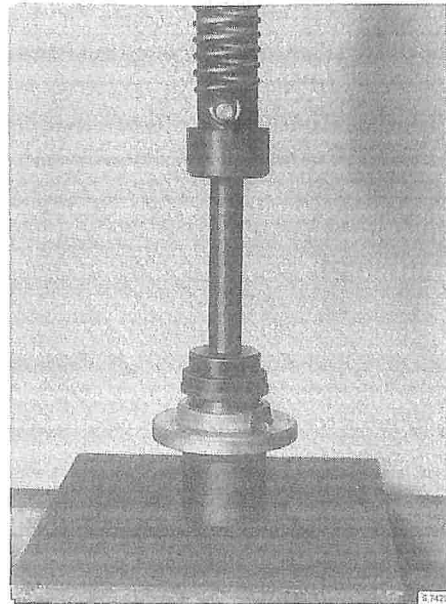

- 5 Maintain the press force of 3 tons. Fit the dial indicator to a bearing housing bolt hole. First apply load to the bearing housing towards the upper bearing and then towards the lower bearing, and read the axial play.

Compensate for the axial play by fitting shims which are available in thicknesses of 0.10, 0.15, 0.25 and 0.50 mm (0.004, 0.006, 0.009 and 0.019 in).

If correctly shimmed, the bearings should have no rolling resistance and no play. If zero play cannot be obtained with the available shim thicknesses, change the spacer. Spacers are available in thicknesses of 8.08, 8.09, 8.10 and 8.11 mm (0.3181, 0.3185, 0.3188 and 0.3192 in).

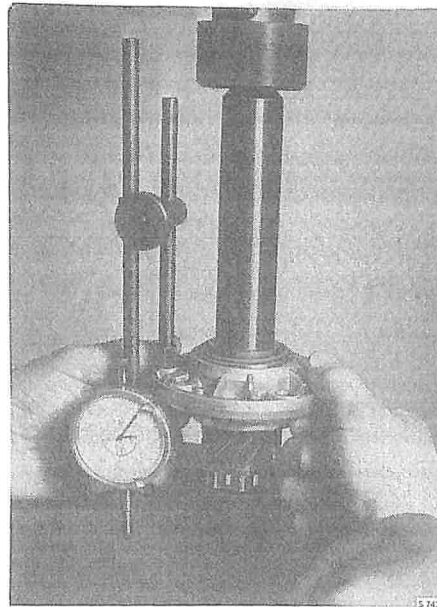

- 6 Press the front bearing off the input shaft and fit the calculated combination of shims. Place the shims between the rear bearing and the spacer. Then fit the front bearing on the input shaft in the bearing housing and press the bearings together with a force of 3 tons. Rotate the bearing housing as described in item 4. above. Check the bearings for rolling resistance and play.
- 7 Fit the oil catcher into the bearing housing.

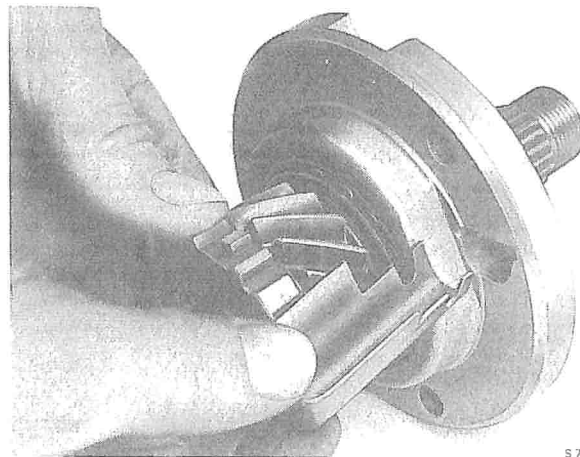

S 7433

To dismantle the selector mechanism with the gearbox removed

- 1 Remove the tubular dowel from the 5th and reverse selector shaft.

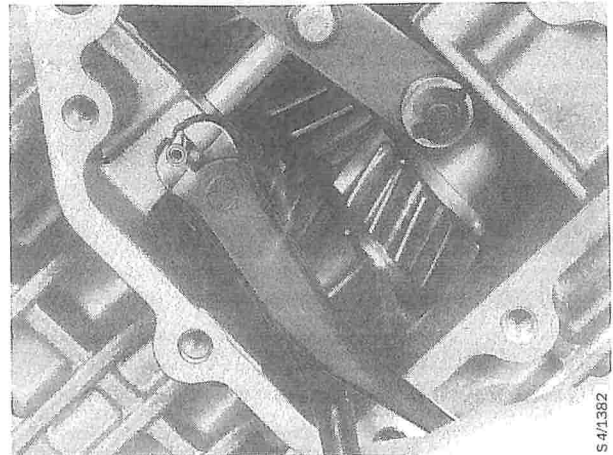

- 2 Remove the 5th actuator.

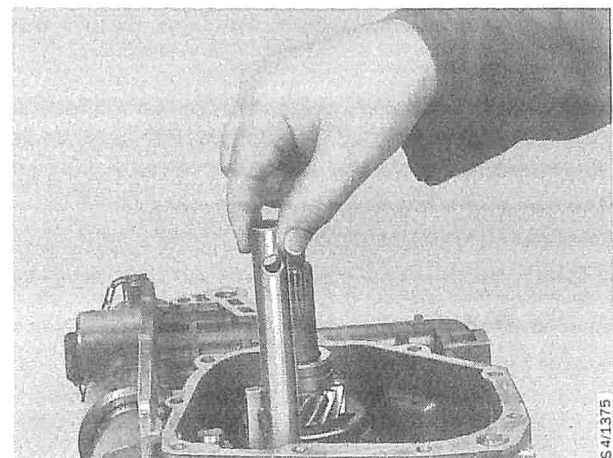

- 3 Remove the selector interlock device.

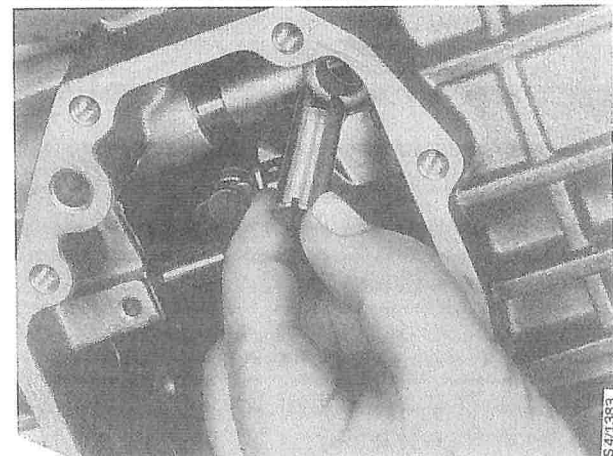

- 4 Remove the 5th and reverse selector shaft.

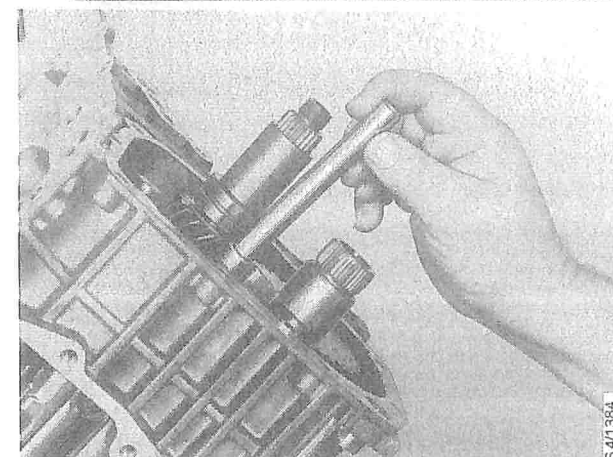

- 5 Withdraw the selector shaft. Remove the spring and ball.

Fit new parts to replace damaged or worn parts.

Assemble in the reverse order.

Selector shaft

To dismantle the selector shaft

Use a 4 mm drift to tap out the tubular dowel. Remove the spring, selector interlock device and actuator.

To assemble the selector shaft

Assemble in the reverse order. See the figure for the locations. Fit new tubular dowels.

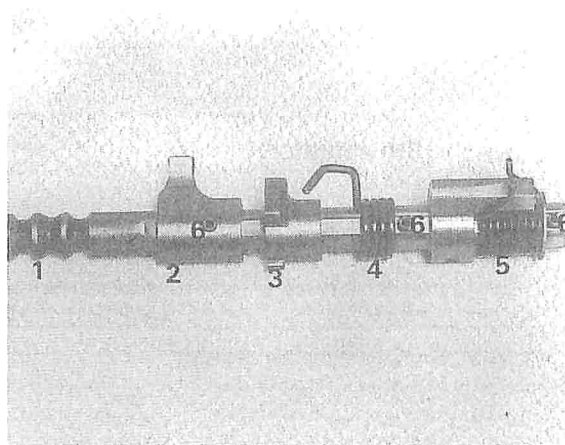
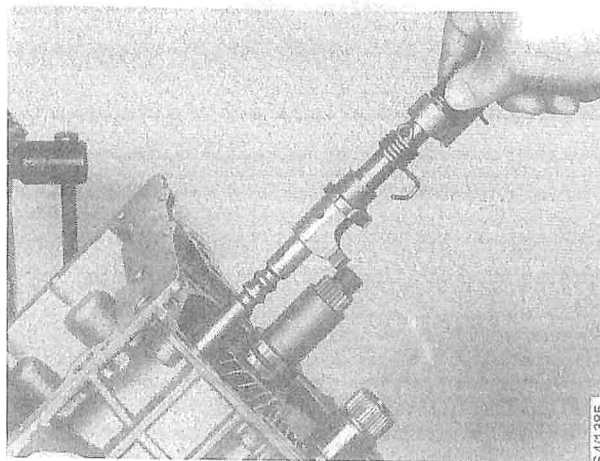

- 1 Shaft
- 2 Actuator
- 3 Selector interlock device
- 4 Reverse brake spring
- 5 Selector guide
- 6 Tubular dowel

Note

The reverse lever need not be removed from the selector shaft when the shaft is removed. The threads of bolt retaining the reverse lever are locked, and the bolt may fail therefore if an attempt is made to remove it.

Make sure not to hammer the tubular dowel in too far during assembly.

Selector mechanism

See "To remove and fit"

The selector mechanism consists of the selector rod, actuators, selector forks, shafts and guide pin, ball and spring.

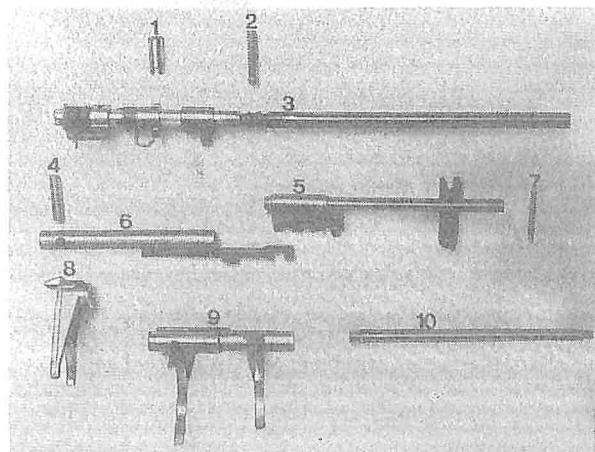

- 1 Plunger
- 2 Spring and ball
- 3 Selector rod
- 4 Plunger
- 5 Reverse gear actuator
- 6 5th actuator
- 7 Tubular dowel
- 8 5th selector fork
- 9 1st, 2nd, 3rd and 4th selector fork
- 10 Shaft

To change the seal and plastic bearing on the selector rod

(Can be carried out either in the car or with the gearbox removed.)

To remove

- 1 Tap out the front taper pin from the selector rod joint and separate the selector rod.
- 2 Drain the oil from the gearcase and remove the differential housing cover.
- 3 Thread tool 87 90 677 over the collar of the seal and screw in the screw towards the rod.
- 4 Use a screwdriver between the tool and the differential housing bolt heads to prise off the seal.
- 5 The plastic bearing is now accessible for removal.

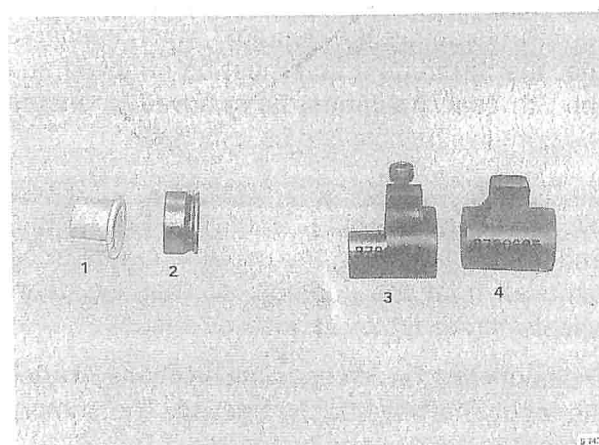

- 1 Plastic bearing
- 2 Seal
- 3 Tool for removing the seal
- 4 Fitting tool

To fit

- 1 Fit the plastic bearing.
- 2 Use tool 87 90 685 and a suitable hammer to fit the new seal.
- 3 Fit the differential housing cover.
- 4 Assemble the selector rod joint and fit the taper dowel.
- 5 Fill the gearcase with oil.

Note

Before fitting, remove any scratches and marks on the projecting part of the selector rod.

Synchromesh mechanism

Baulk rings

To change the baulk rings, follow the description for "To dismantle the gearbox" which specifies that the differential unit must be removed and the 5th gearwheel must be removed to enable the primary chaincase to be removed.

No further dismantling is necessary to change the 4th gear baulk ring. To change the 1st and 2nd gear baulk rings, the output shaft must be removed from the gearbox, so that the gearwheels can be removed from the shaft.

The baulk ring for 5th gear can be changed after the input shaft has been removed. The primary chaincase need not be removed.

To dismantle

To dismantle the synchromesh unit, remove the circlip retaining the baulk ring on the gearwheel. To remove the 5th baulk ring, remove the circlip at the guide ring. The circlip at the baulk ring need not be removed.

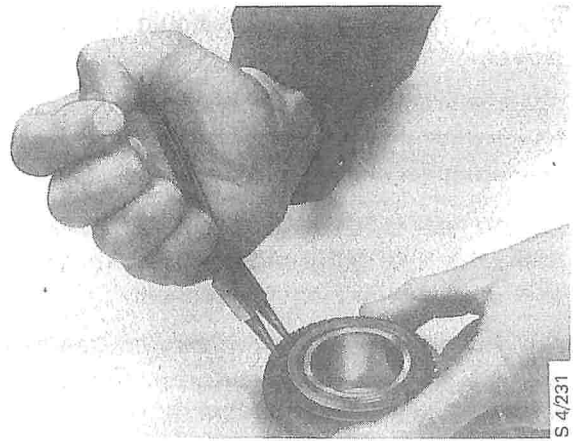

To assemble

First fit the guide ring for the springs and the circlips for the 3rd and 4th gearwheel guide rings. The 1st and 2nd gearwheels have no circlips for the guide rings. Fit the spring with the long end towards the guide ring and locate it so that there are eleven teeth between the spring ends. Locate the baulk ring so that the ends of the spring are between the teeth of the baulk ring and then fit the circlip.

(The spring for 1st gear synchromesh is softer and its free length is smaller than the others.)

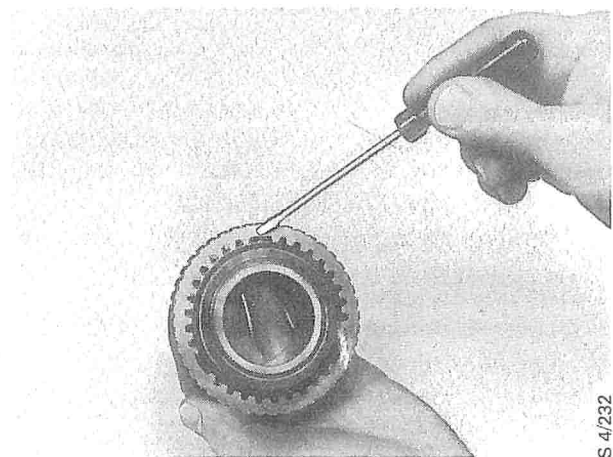

Note

The guide rings on 3rd and 4th gearwheels fitted in production are peened in position in a special tool after the circlip has been fitted. The guide rings supplied as spares should not be peened.

Guide plate 87 02 730 together with pear-shaped circlip 8702722 should be used as spare parts.

As an alternative, use a complete unit 87 11 632 consisting of the gearwheel and factory-fitted synchronesh unit.

Fit 5th gear baulk ring. Fit the springs so that there are five teeth between the spring ends. Then fit the guide ring and circlips.

The 2nd and 3rd synchronesh unit has molybdenum-coated conical surfaces. This type of baulk ring is also suitable for 1st and 4th gears.

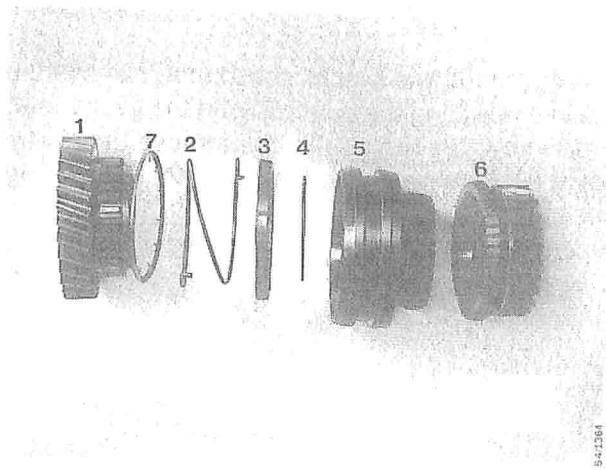

1st and 2nd gear synchronesh unit

- 1 2nd gearwheel
- 2 Guide ring
- 3 Spring for 2nd gear
- 4 Baulk ring
- 5 Circlip
- 6 Synchronesh hub
- 7 Synchronesh sleeve
- 8 Spring for 1st gear
- 9 1st gearwheel

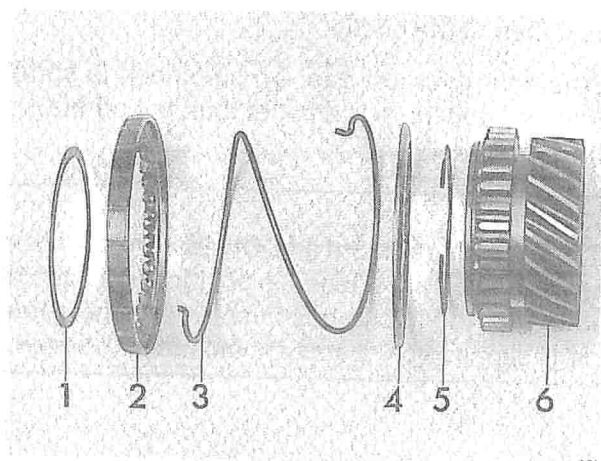

3rd gear synchronesh unit

- 1 Circlip
- 2 Baulk ring
- 3 Spring for 3rd gear
- 4 Guide ring
- 5 Circlip for guide ring (due to a dimensional error, some gearwheels may be fitted with two circlips)
- 6 3rd gearwheel

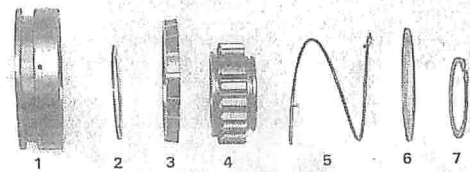

57414

5th gear synchromesh unit

- 1 Synchromesh sleeve
- 2 Circlip
- 3 Baulk ring
- 4 Synchromesh hub
- 5 Spring
- 6 Guide ring
- 7 Circlip

Ventilation

The gearcase is ventilated through a hole in the top cover of the primary chaincase. The hole is at the centre of a plastic propeller secured to the clutch shaft.

When the clutch shaft rotates, oil is flung away from the hole by the propeller.

When the clutch shaft is stationary, the oil level in the primary chaincase is well below the hole.

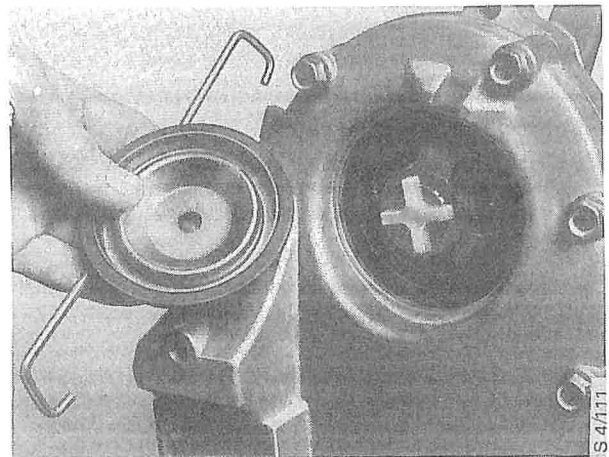

S 4/111



Differential and pinion/crown wheel

To adjust the pinion	473-1	To adjust the crown wheel backlash	473- 5
Before measuring	473-2	Measuring and shimming	473- 6
To measure	473-2	To adjust the crown wheel backlash	473- 8
Shimming	473-3	Differential - to remove and dismantle	473- 9
Checking after shimming	473-4	Inner universal joint driver with differential	
To check the measuring jig	473-4	bearing housings	473-10

General

The crown wheel and pinion are matched and may be replaced only as a pair. The parts are tested together, and the optimum setting for minimum noise is then determined. The dimensions which are important for the pinion and crown wheel are the distance between the end face of the pinion and the centre of the crown wheel, and the backlash between the teeth. These dimensions and the matching number are stamped on both parts after testing. When the pinion and crown wheel are fitted, these dimensions must be accurately adjusted with shims, using a special measuring instrument. The pinion shims are located at the bearing housing, whereas the crown wheel (differential) shims are located at the two differential bearing housings.

Important note

Always measure the positions of the pinion and crown wheel before dismantling the gearbox. This is to check whether their locations are correct. If the pinion and crown wheel assembly has been in service for a relatively short distance (less than 10 000 km) re-adjustment may be carried out. But if it has been in service for a longer distance and the gears have become worn-in, their settings during re-assembly should be the same as those measured before dismantling.

To adjust the pinion

General

The dimensions for adjusting the distance between the face of the pinion and the centre of the crown wheel are stamped into the end face of the pinion (see example below).

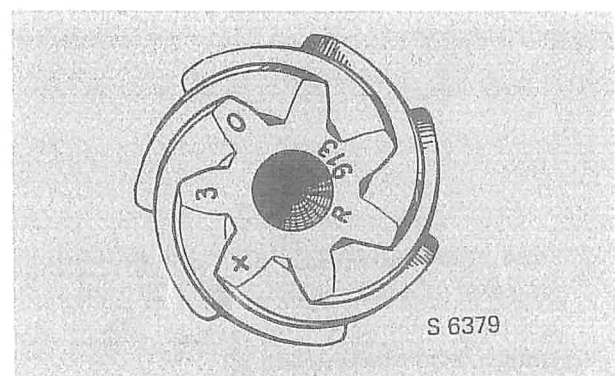

End face of pinion

- +3 = Dimension for setting the pinion
- R913 = Matching number, also stamped on the crown wheel
- 0 = Pinion not offset - its centreline intersects the crown wheel centreline. All pinions are stamped 0, and this figure is not relevant to the adjustment.

Before measuring

Note the following when measuring the pinion setting:

Car with manual gearbox: The gearbox output shaft bearings should be preloaded so that the torque necessary to rotate the pinion is 2.5 ± 0.5 Nm (1.8 ± 0.4 lbf ft). This applies to new, lightly oiled bearings. The corresponding figures for older bearings (in service more than 2000 km) are 1.3 ± 0.5 Nm (1.0 ± 0.4 lbf ft).

The differential should be removed to allow the measuring tool to be fitted. Measuring tool 83 90 155 consists of a jig to which a dial indicator is secured. A slip gauge is available for adjusting the dial indicator, and this should be placed against the calibration pads of the jig. The distance between these pads and the centreline of the crown wheel is always 60.000 mm (2.362 in) (see figure). The procedure for measuring the pinion setting is as follows:

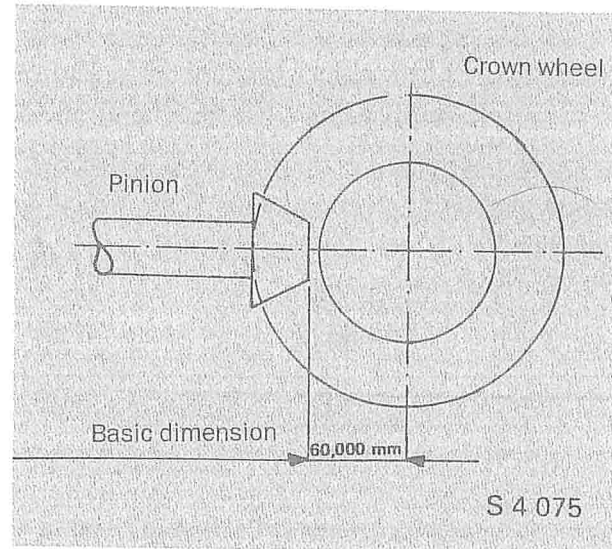

To measure

- 1 Check that the pointers of the dial indicator are zeroed when the indicator tip rests on the slip gauge.
- 2 Place the measuring tool in the differential housing bearing seats, with the dial indicator tip resting on the ground end of the pinion, and take a reading.
- 3 If the pinion is correctly set, the dial indicator reading in hundredths of a millimetre (+ or -) should be as stamped on the pinion. The permissible tolerance is ± 0.05 mm (0.002 in).

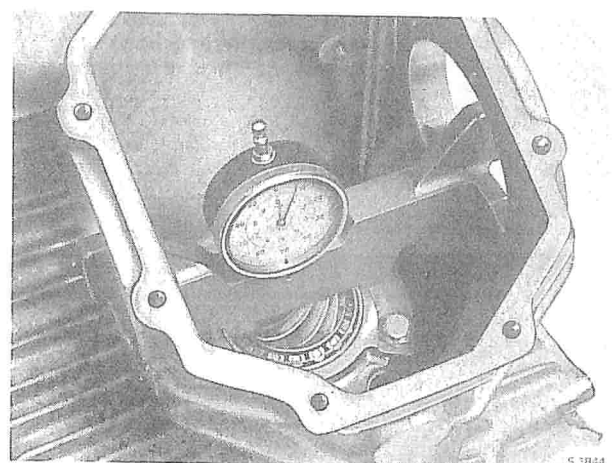
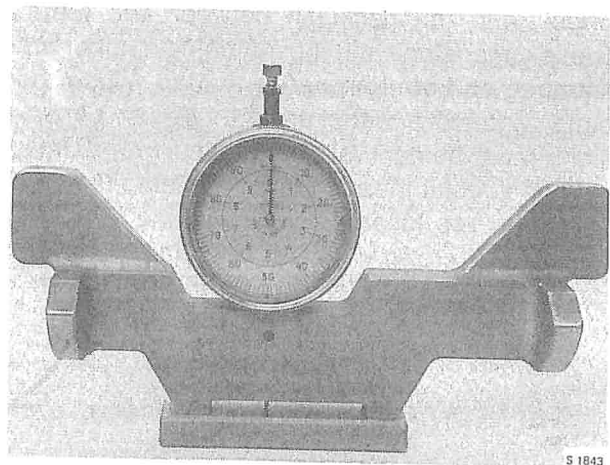

Shimming

If the reading obtained is outside the tolerance range, the pinion must be adjusted. Adjustment is carried out by shimming between the bearing housing and the gearcase.

Shim table for manual gearbox

Location	Shims	
	Thickness, mm (in)	Part No.
Between bearing housing and gearcase	0,10 (0.003)	83 41 752
	0,15 (0.005)	83 41 760
	0,30 (0.012)	83 41 778
	0,50 (0.020)	83 41 723

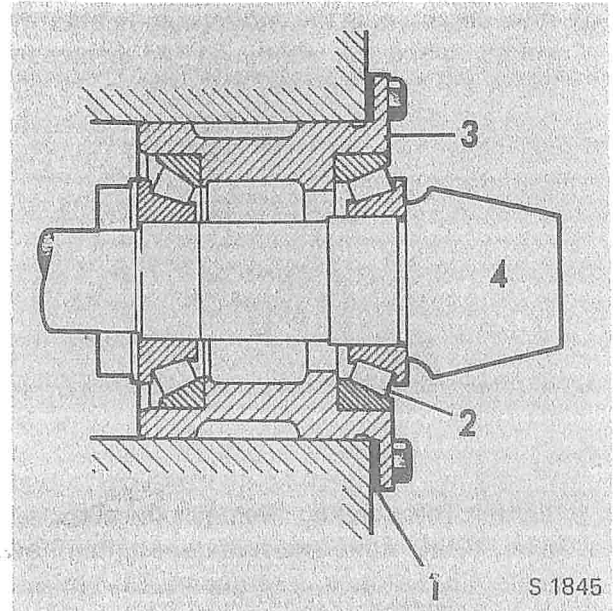

Pinion adjustment on manual gearbox

- 1 Shims
- 2 Roller bearing
- 3 Bearing housing
- 4 Pinion

The shimming procedure is as follows:

- 1 Remove the four bearing housing bolts and gently tap the shaft out of the gearcase.
- 2 Alter the shim thickness as follows:

If the dial indicator reading is high, increase the thickness of the shim combination.

If the reading is low, reduce the thickness of the shim combination.

Note. A + reading is anti-clockwise and a - reading is clockwise. The amount by which the thickness of the shims is increased or decreased can be determined by calculating the difference between the measured value and the correct value.

If the pinion is stamped - 7, the dial indicator pointers should read - 0.07 mm (0.003 in). The tolerance on this value is ± 0.05 mm (0.002 in).

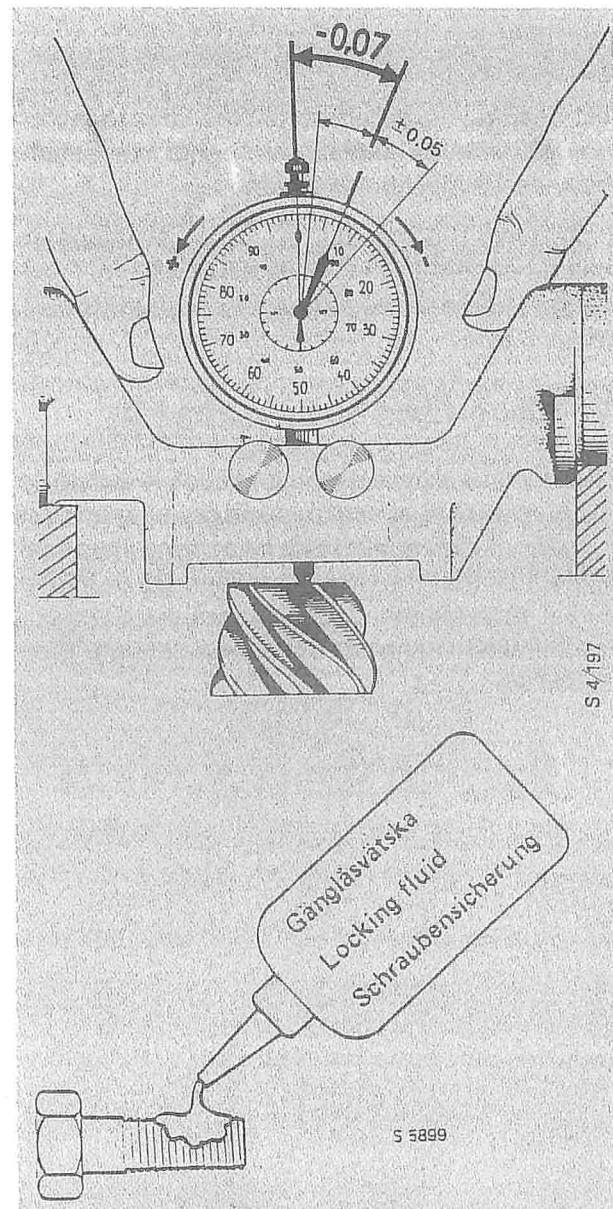

473-4 Differential and pinion/crown wheel

- 3 After determining the correct combination of shims, place the shims on the gearcase using the locating pins. Use sleeve 83 90 148 and drift 83 90 114. Remove the locating pins and tighten the bolts to the specified torque.

Fit two of the bearing housing bolts and tighten them lightly. Remove the locating pins, fit the other two bolts and tighten all bolts alternately to a torque of 23 - 28 Nm (17 - 21 lbf ft).

Checking after shimming

After shimming, replace the measuring jig in the differential bearing seats and check that the correct reading is obtained on the dial inductor (± 0.05 mm or 0.002 in). If not, the shim thicknesses must be re-adjusted.

If the pinion is marked +3, the dial indicator reading should be +0.03mm (0.0012 in). The tolerance on this reading is ± 0.05 mm (0.002 in).

To check the measuring jig

The measuring jig is a precision tool. It should be handled with great care to avoid bruising and deformation. If damage to the measuring jig is suspected, so that the wrong readings are obtained during measurement, the jig can be checked. The dimension shown in the figure should then be checked.

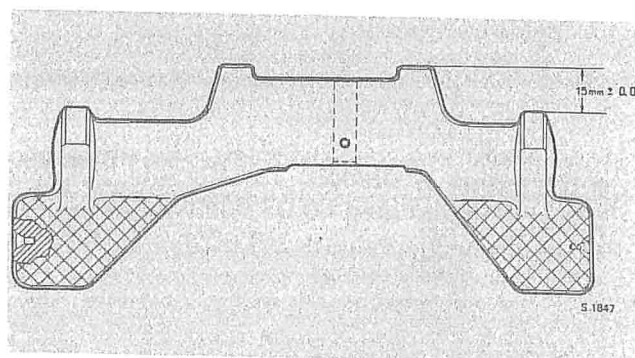
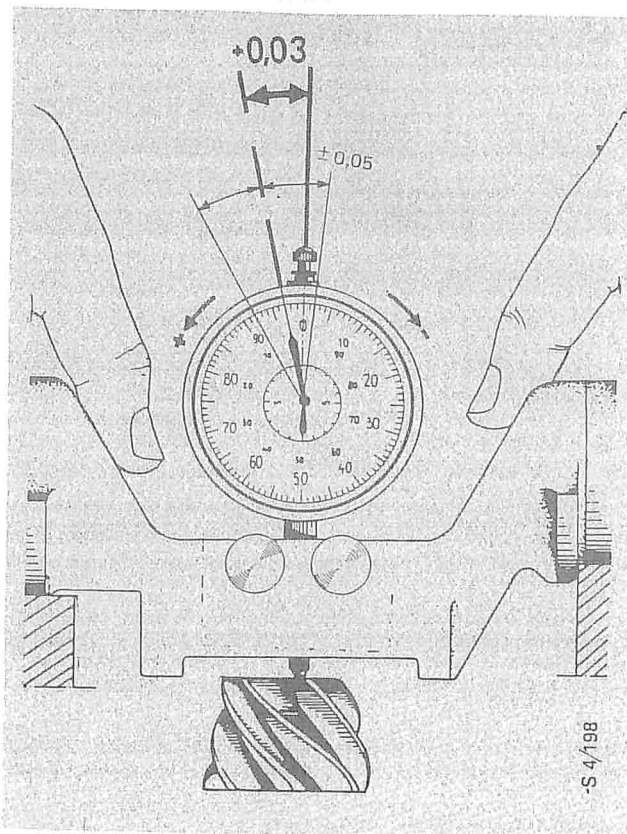

To adjust the crown wheel backlash

Certain information for adjusting the crown wheel backlash is stamped on the crown wheel as shown in the figure.

Note

If new parts are fitted, adjust the backlash to 0.1 ± 0.05 mm (0.004 ± 0.002 in).

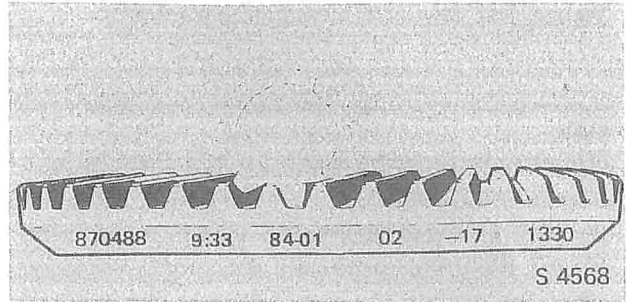

Crown wheel markings

- 870488 = item number (not part number)
- 9:33 = ratio
- 84-01 = production and identification date
- 02 = material code
- 17 = backlash of 0.17 mm (0.007 in)
- NB** If this information is not specified, assume 0.17 ± 0.05 mm (0.007 ± 0.002 in)
- 1310 = matching number which is also stamped on the pinion.

If the parts have been in service less than 10 000 km, adjust the backlash to 0.17 ± 0.05 mm (0.007 ± 0.002 in).

Shim table

Location	Shims	
	Thickness, mm (in)	Part No.
Between bearing housing and gearcase	0,10 (0.003)	83 41 604
	0,15 (0.005)	83 41 612
	0,30 (0.012)	83 41 620
	0,50 (0.020)	83 41 638

Check the backlash at four points around the circumference of the crown wheel, and the deviation must not exceed ± 0.05 mm (0.002 in) from the specified value. Adjustment of the crown wheel backlash is carried out by shimming. Up to four shims in suitable combinations may be used.

Measuring and shimming

To adjust the differential bearings

Note

Adjustment must be carried out before the output shaft is fitted.

(If only the final drive has been dismantled for replacement of the differential bearings, the crown wheel must also be removed when the preloading of the bearings is adjusted.)

- 1 Place the differential in the gearcase.
- 2 Fit the left-hand bearing housing (with speedometer drive) without shims, and tighten the bolts to the specified torque.

Tightening torque for the left-hand bearing housing:

23 - 28 Nm (17 - 21 lbf ft)

- 3 Oil the differential bearings and fit the right-hand bearing housing. Tighten the bolts in two or three stages. Rotate the differential while tightening the bolts.

Tightening torque for the right-hand bearing housing:

2.2 Nm (1.6 lbf ft)

- 4 Use feeler gauges to measure the clearance between the gearcase and the bearing housing at two points opposite one another and calculate the mean value. Then select shims corresponding to the calculated dimension, but **add 0.20 mm (0.008 in)** to ensure correct preloading of the bearings.

Note

The method described above applies to both new and old bearings.

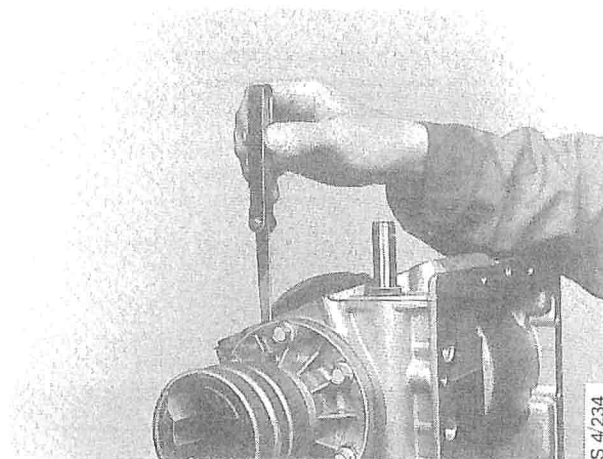
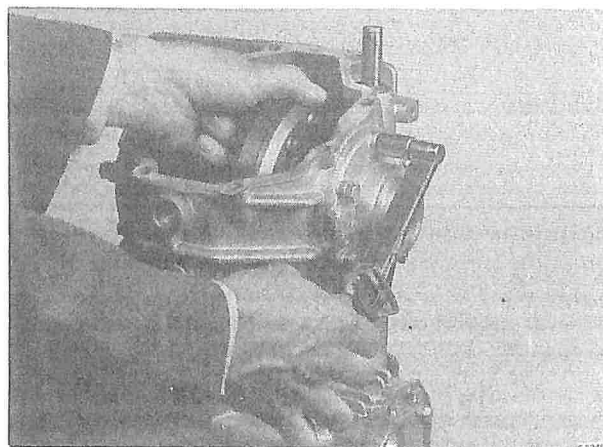

The result of this preloading can be measured by means of a torque spanner and driver 87 90 818.

Adjust to the correct value. The rolling resistance values are tabulated below:

Note

New, lightly oiled bearings:

1.8 - 2.8 Nm (1.33 - 2.07 lbf ft)

Bearings that have been in service more than 2000 km:

0.8 - 1.3 Nm (0.59 - 0.95 lbf ft)

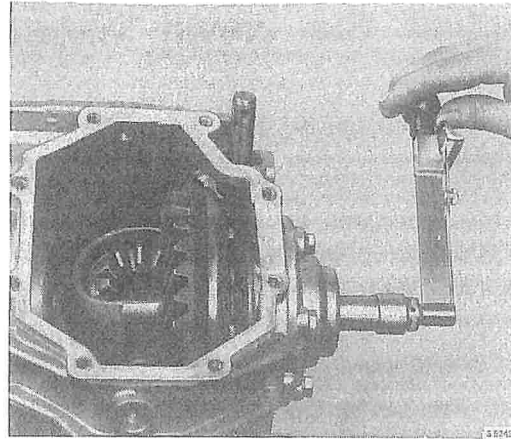

Suitable combinations of four different shim thicknesses can be used for shimming. The available shims thicknesses are tabulated below.

Note

The set of shims should be distributed onto the right-hand and left-hand sides to obtain the correct backlash.

Shim table

Location	Shims	
	Thickness, mm (in)	Part No.
Between bearing housing and gearcase	0,10 (0.003)	83 41 604
	0,15 (0.005)	83 41 612
	0,30 (0.012)	83 41 620
	0,50 (0.020)	83 41 638

To adjust the crown wheel backlash

- 1 Place the differential with crown wheel in the gearcase.
- 2 Fit the left-hand bearing housing (with speedometer drive) without shims and the right-hand bearing with the set of shims selected earlier. Tighten the bolts to the specified torque.

Tightening torque for the left-hand and right-hand bearing housings:

23 - 28 Nm (17 - 21 lbf ft)

- 3 Set up the dial indicator as shown in the figure and measure the backlash.
- 4 Calculate the difference between the measured and calculated backlash, and then move a suitable thickness of shims to the left-hand bearing housing. Then check the backlash again.

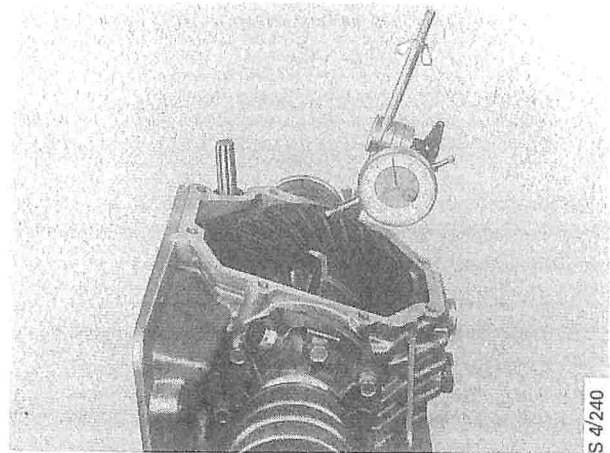

Note

When adjusting the backlash, use the set of shims selected earlier. The total thickness of shims must not be altered.

Differential

To remove and dismantle

- 1 Remove the final drive cover.
- 2 Remove the two differential bearing housings. Save the shims and remove the differential.
- 3 Remove the speedometer drive and press out the differential bearings. Use tools 89 96 084, 87 90 768 and 89 95 177. For particulars of changing the outer bearing races, see under "To dismantle the inner universal joint driver".
- 4 Remove the dowel securing the differential pinion shaft and carefully tap out the shaft. Save the pinion and the wear washers.
- 5 Remove the crown wheel bolts and remove the crown wheel.

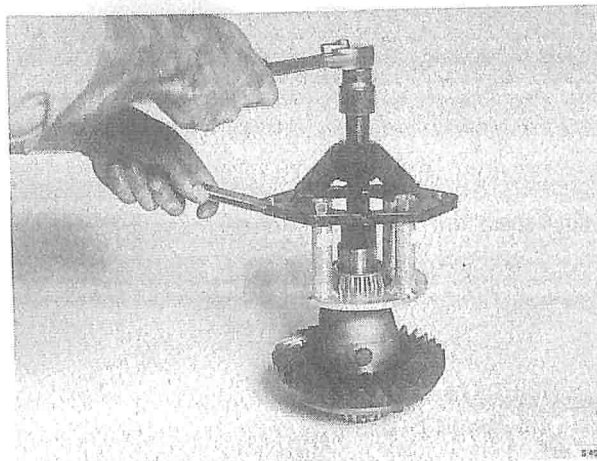

To assemble and fit

- 1 Replace any worn or damaged parts by new ones.
- 2 Press the bearings into place and fit the speedometer drive. Use tool 87 90 487.
- 3 Fit the differential and differential bearing housings into the gearcase. Check the bearing preload and adjust the shimming as necessary (see under "Inner universal joint driver with differential bearing housings").
- 4 Fit the differential and bearing housings.

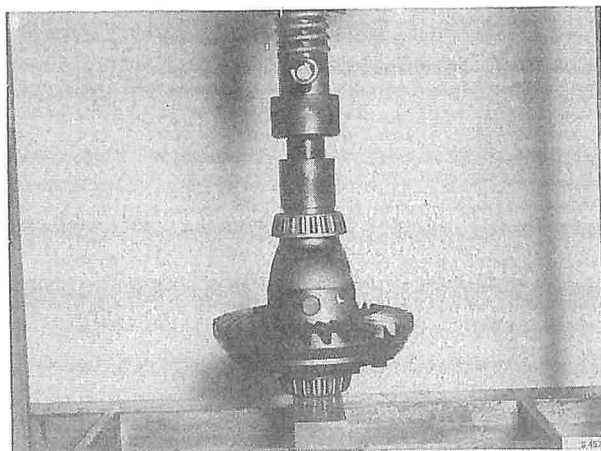

- 5 Fit the crown wheel, apply locking compound to the bolts and tighten them to the specified torque.

Tightening torque:

90 ± 10 Nm (66 ± 7 lbf ft)

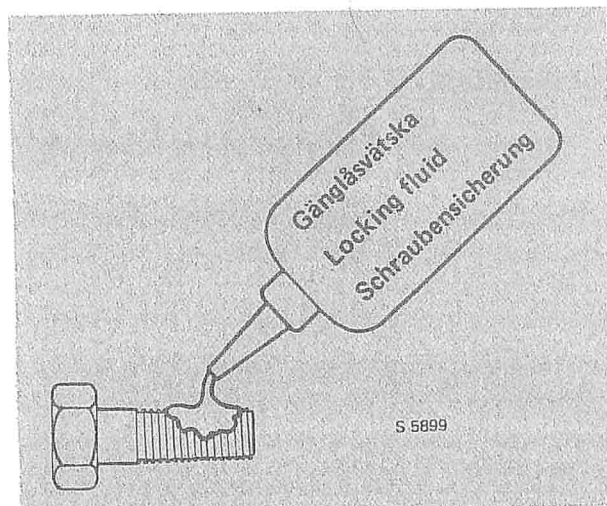

- 6 Place the pinions and wear washers in their appropriate positions and insert the differential pinion shaft. Fit the dowel.
- 7 Fit the differential and the differential bearing housings into the gearcase.
- 8 Check and, if necessary, adjust the crown wheel backlash (see under "Inner universal joint driver with differential bearing housings").

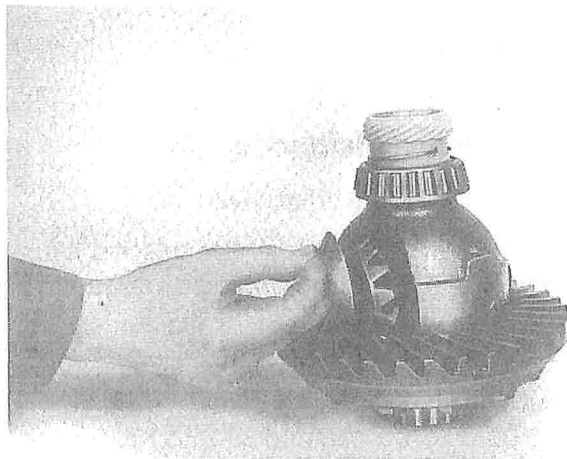

- 9 When finally fitting the differential bearing housings, apply sealing compound to the 12 bolts.

Tightening torque:
23 - 28 Nm (17 - 21 lbf ft)

- 10 Fit the final drive cover

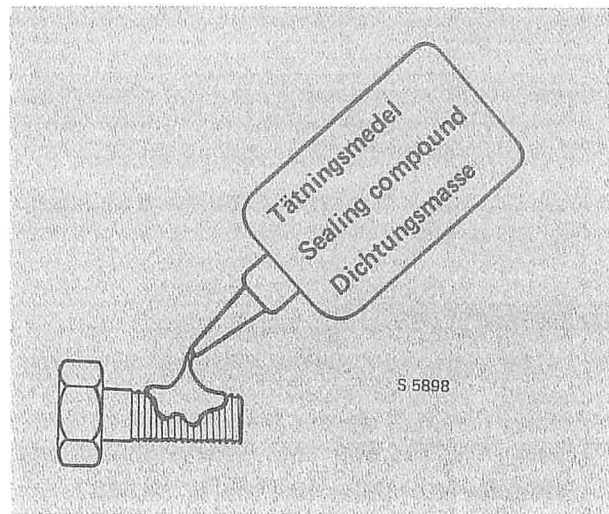

Inner universal joint driver with differential bearing housings

To remove

Remove the bolts for the differential bearing housing and use puller 87 90 776 and slide hammer 83 90 270 to remove the housing together with the universal joint driver. Save the shims.

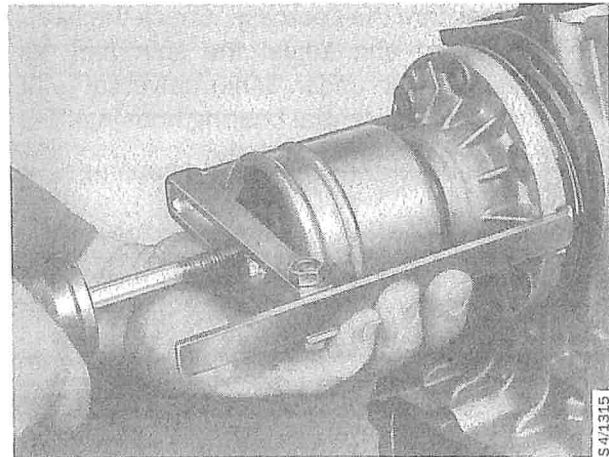

To dismantle

- 1 Remove the circlip from the universal joint driver.



- 2 Press the universal joint driver out of the differential bearing housing.
- 3 Use a screwdriver to remove the seal, but take care not to damage the bearing housing.
- 4 Remove the speedometer drive from the left-hand bearing housing.
- 5 Use sleeve 78 41 067 to press out the ball bearing.

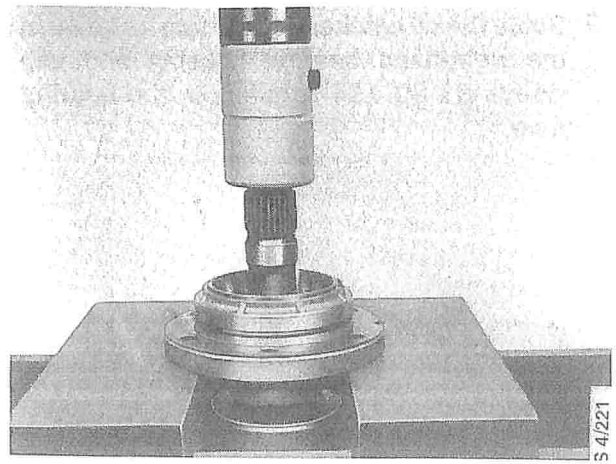

- 6 Use a suitable drift to remove the differential bearing races. The right-hand differential bearing housing (without speedometer drive) includes a washer on the inside of the bearing race, the function of which is to improve the lubrication of the ball bearing.
- 7 Remove the O-ring from the bearing housing groove.

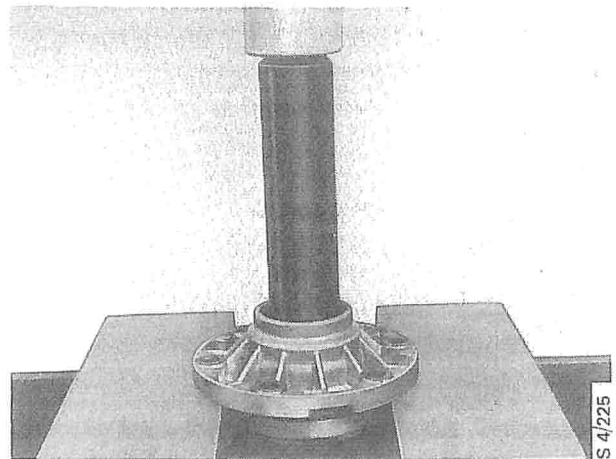

Inner universal joint driver with bearing

- 1 Inner universal joint driver
- 2 Spring with plunger
- 3 Seal
- 4 Bearing housing
- 5 Ball bearing
- 6 Circlip
- 7 Oil level washer
- 8 Bearing race
- 9 O-ring

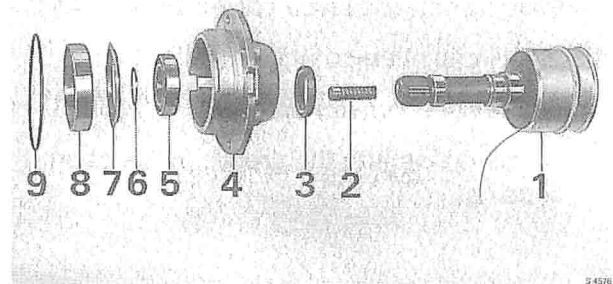

To assemble

- 1 Use sleeve 78 41 141 to press the ball bearing into the bearing housing.

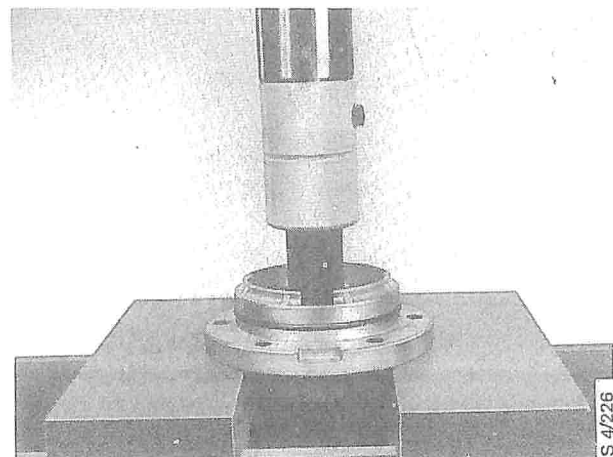

- 2 Guide the oil catcher washer into its groove in the right-hand bearing housing and use sleeve 83 90 114 to press in the bearing race.

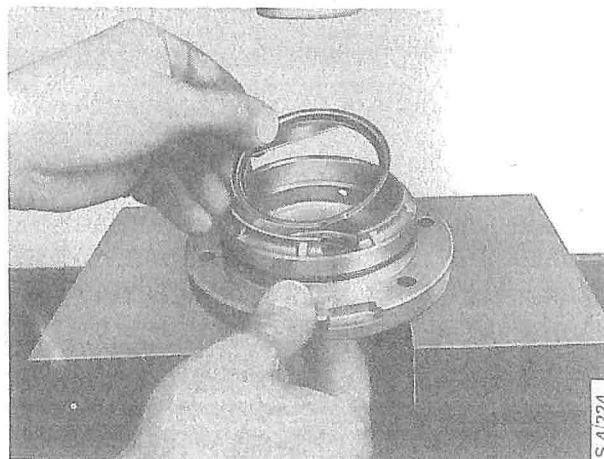

- 3 Use drift 87 90 800 to press in the seals so that they will be about 2 mm above the face of the bearing housing.

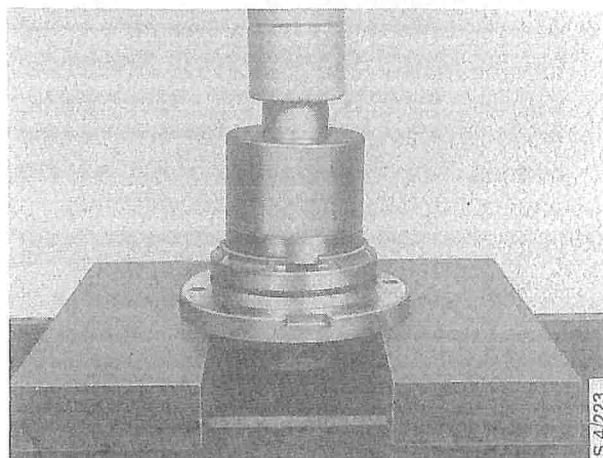

- 4 Adjust the bearing preload and the backlash (see page 473-6). This applies only to the right-hand side.
- 5 Use sleeve 78 41 067 to press the bearing housing onto the universal joint driver shaft.
- 6 Use circlip pliers to fit the circlip.
- 7 Fit the speedometer drive.
- 8 Fit the O-ring into the groove in the bearing housing.

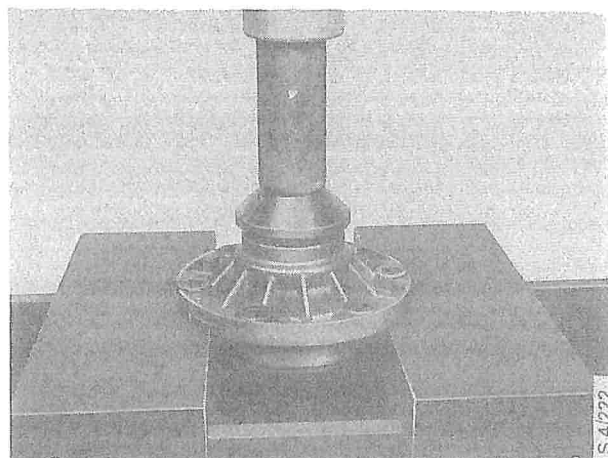

To fit

For particulars of adjustment of the differential bearing preload and adjustment of the backlash, see page 473-6.

- 1 Ensure that the O-ring is fitted to the bearing housing and fit the spring with plunger into the hole in the driver shaft end.
- 2 Fit the measured combination of shims to the two bearing housings and fit the housings, together with the inner universal joint drivers, to the gearcase.

Apply thread sealing compound to the threads of the 12 bolts.

- 3 While tightening the bearing housings, check that there is backlash in the gear teeth. Tighten the bolts to the specified torque.

Tightening torque for the differential bearing housings:

23 - 28 Nm (17 - 21 lbf ft)

- 4 Check the backlash by measuring at four places.

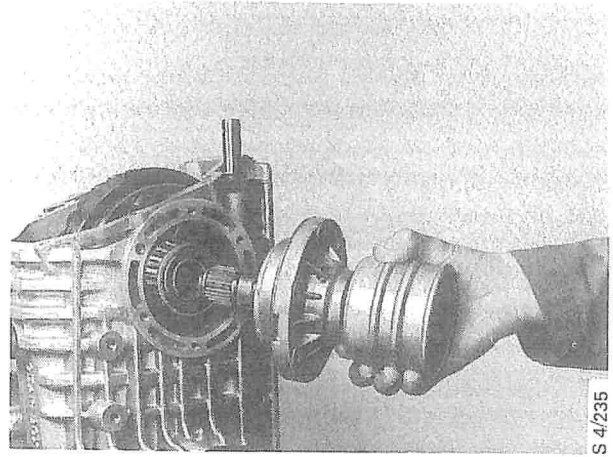

S 4/235

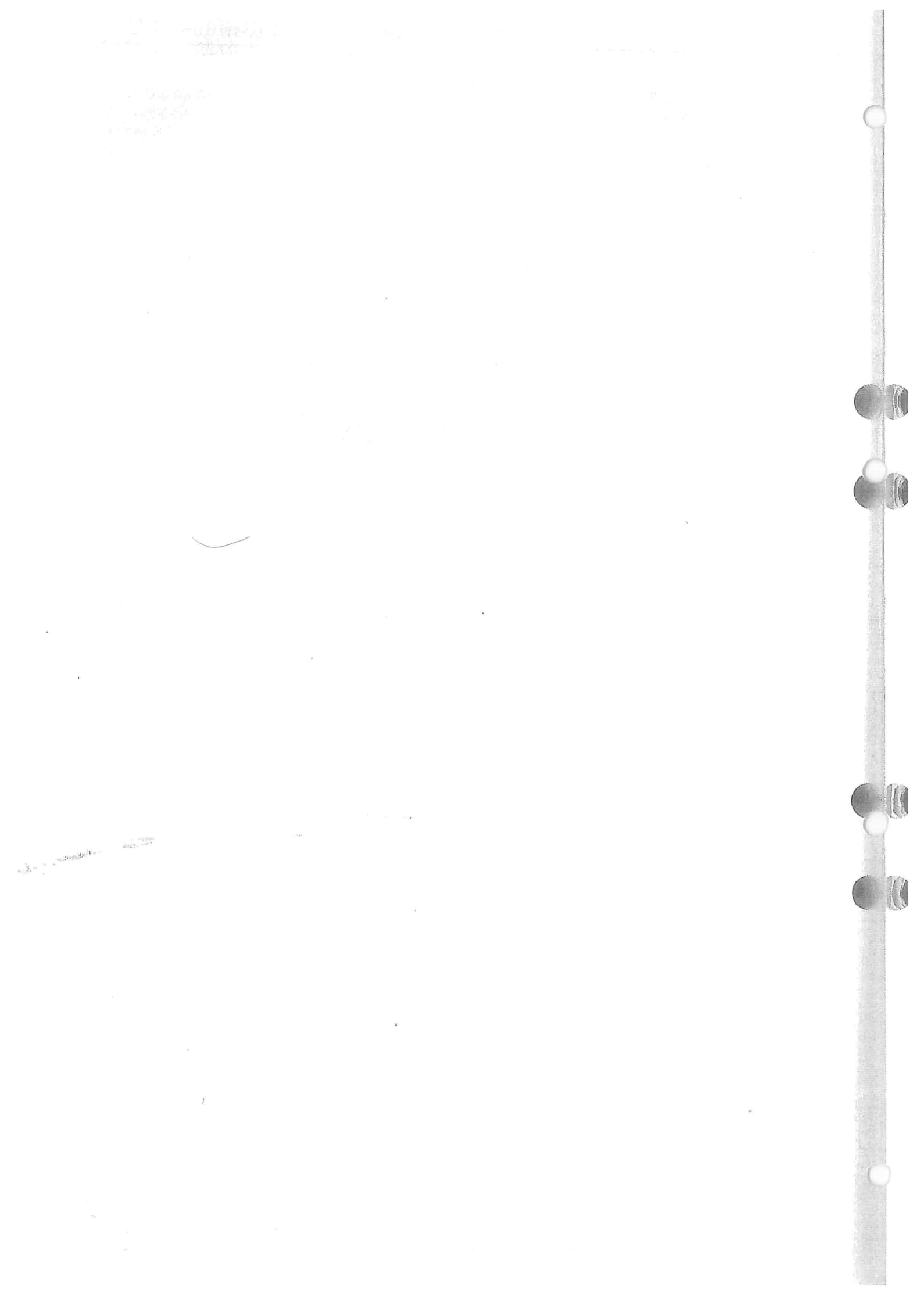

Universal joints

Inner universal joint	475-1	To fit	475-2
To remove	475-2	Outer universal joint	475-4

Inner universal joint

The inner universal joint consists of a driver journalled in a ball bearing in the differential bearing housing and splined into the differential wheel. The driver is locked axially by a circlip on the inside of the ball bearing, and by a spring and plunger at the driver end resting on the differential shaft.

The driver can be removed from the gearbox together with the differential bearing seat.

The outside of the driver is in the form of a sleeve which is slotted for the three-bearing universal joint of the inner drive shaft. When the car is travelling, the universal joint, which is equipped with needle bearings, can slide axially in the driver cup, and its angle in relation to the axis of the driver is also free to change. The universal joint is packed with grease and is protected by a rubber gaiter. Greasing of the universal joint need only be carried out after overhaul or if the universal joint is dismantled for any other reason.

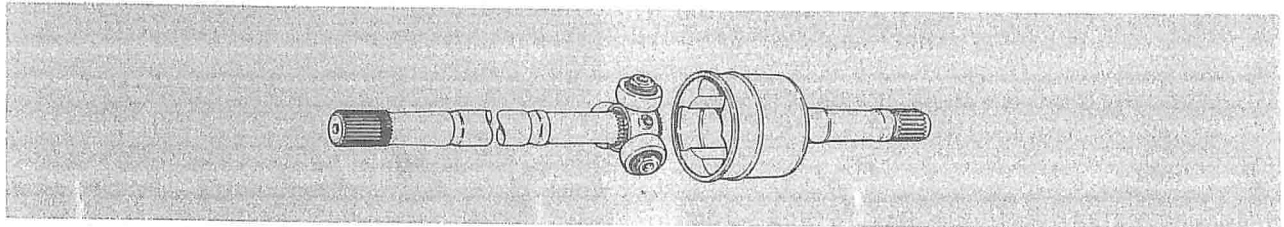

Inner universal joint and inner drive shaft

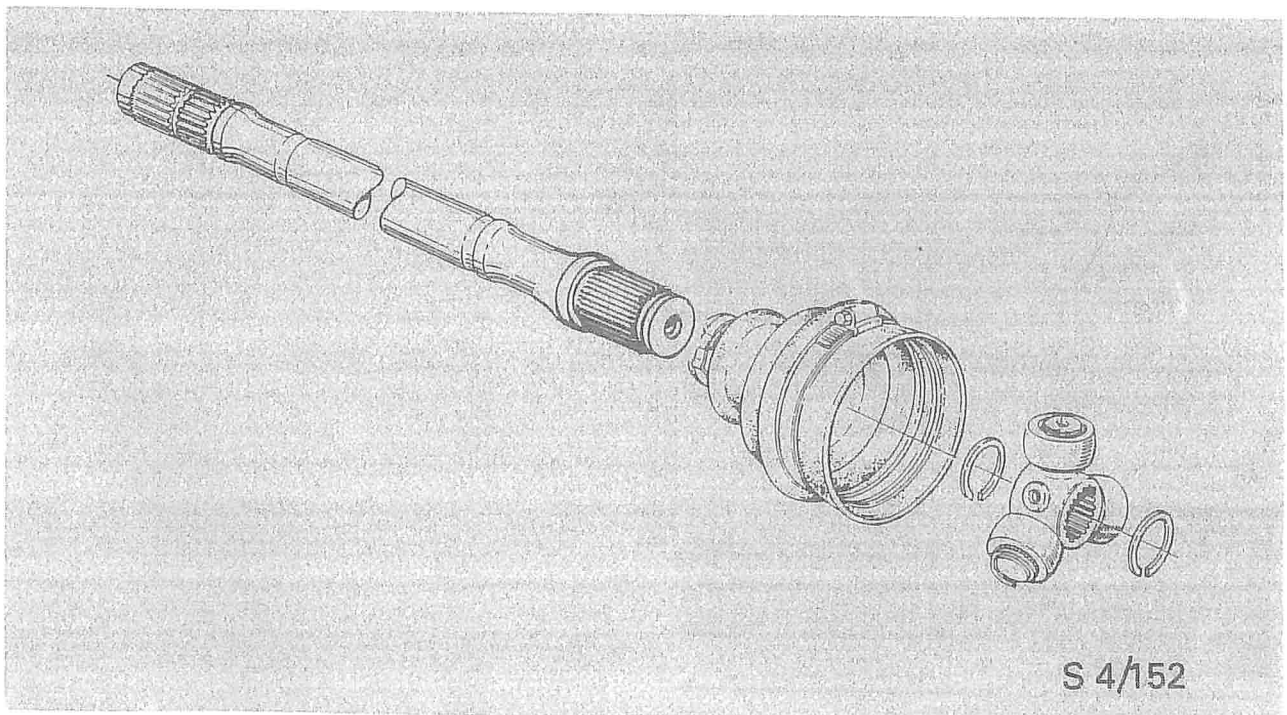

To remove

- 1 a Release the upper mounting of the shock absorber before lifting the car.
- 1 b Lift the front of the car and remove the wheel.
- 2 Remove the brake caliper and suspend it at the wheel housing to avoid damage to the brake hose, and then remove the brake disc.
- 3 Remove the large clip from the rubber gaiter on the inner universal joint. When separating the inner universal joint, fit cover 73 23 736 to the rubber gaiter to prevent the needle bearings from dropping out and to keep dirt out of the universal joint. Fit protective cover 78 38 469 to the inner universal joint driver.
- 4 Use tool 89 95 409 to disconnect the track rod from the steering arm and remove the nut from the upper ball joint. Remove the bolts from the lower wishbone mounting.
- 5 Withdraw the drive shaft through the wheel housing and remove the entire front axle assembly.
- 6 See section 473 for particulars of removing the inner driver from the gearbox and refitting it.
- 7 If the rubber gaiter at the inner or outer universal joint is to be replaced, release the drive shaft from the inner universal joint (see "Outer universal joint").

The rubber gaiters can then be removed from the shaft.

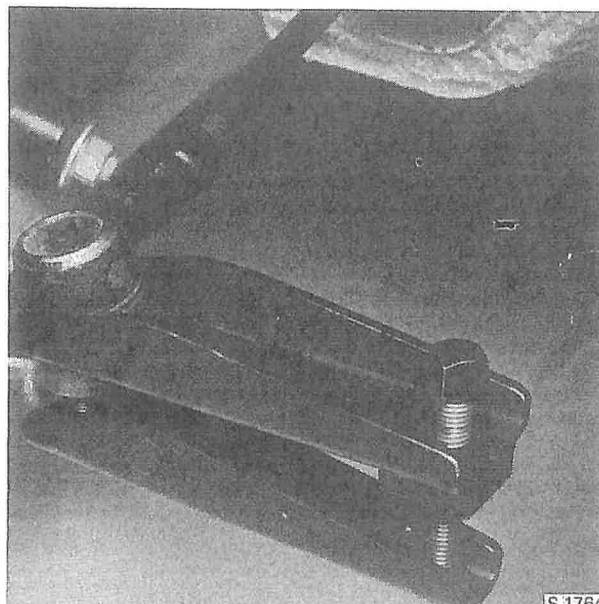

To fit

- 1 Make sure that the inner driver has been washed clean and then pack it full of grease. To ensure that the universal joint is packed with the correct quantity of grease, also pack the rubber gaiter. A total of 130 g of grease is required, of which about 80 g can be packed into the inner driver.

Lubricant

Use a soft, lithium-lead based EP grease capable of withstanding wide temperature and load variations. Consistency: Esso Beacon EP2 or equivalent.

- 2 Thread the rubber gaiters onto the drive shaft, and fit the shaft and rubber gaiter to the outer universal joint (see "Outer universal joint").
- 3 Pack the needle bearings with grease and fit the bearings onto the drive shaft studs. Fit cover 73 23 736 to the rubber gaiter to protect the needle bearings and prevent them from dropping out. Then insert the shaft with the rubber gaiter through the wheel housing.
- 4 Remove the cover from the rubber gaiter and push the shaft with the needle bearings into the inner driver. Then secure the rubber gaiter with the clips.
- 5 Fit the steering swivel housing and the steering arm.
- 6 Fit the brake disc and caliper.
- 7 Place a jack under the outer end of the lower wishbone. Raise the wishbone slightly and fit the shock absorber nuts.
- 8 Fit the wheel and lower the front of the car.

Caution

The brake pads must be returned to their correct positions close to the brake disc by repeated pumping of the brake pedal. This is necessary to ensure good performance of the foot brake.

Outer universal joint

General

The outer universal joint transmits power from the intermediate to the outer drive shaft. The inner end of the outer shaft is bell-shaped with spherical tracks in which six balls transmit power from a hub. The intermediate drive shaft is splined to the hub and is secured axially by means of a circlip accessible through a recess in the hub. The hub, balls and outer shaft are matched and must not be interchanged. Greasing of the universal joint is necessary only after a universal joint has been overhauled or has been dismantled for any other reason.

To dismantle and assemble

See Group 7, section 774.

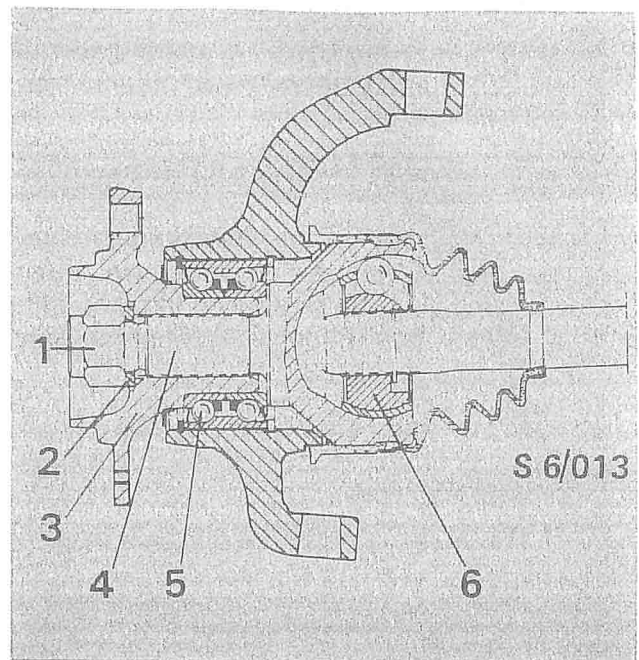

Outer universal joint

- 1 Locknut
- 2 Washer
- 3 Hub
- 4 Outer drive shaft
- 5 Bearing with seals
- 6 Outer universal joint





SAAB

Saab Automobile AB
Trollhättan, Sweden



Ordering No. 318378. English edition. Printed in Sweden. © Saab Automobile AB, 1991.

